



Laboratoire d'Annecy-le-Vieux
de Physique des Particules

FD supports

A.Jeremie



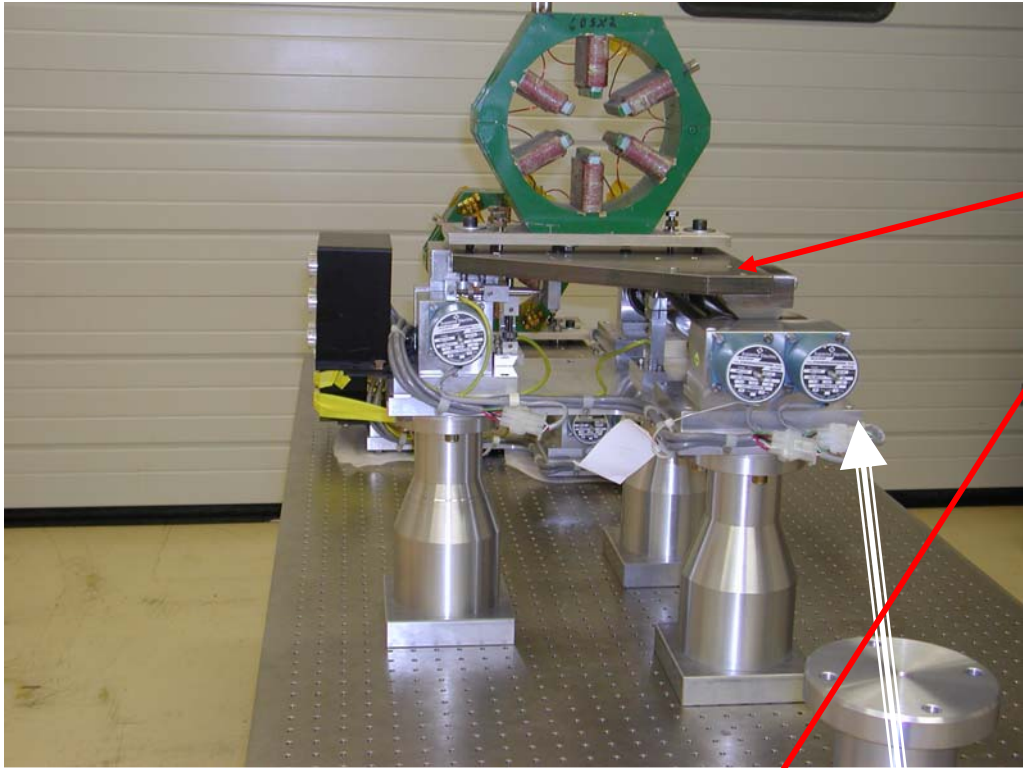

V-plate

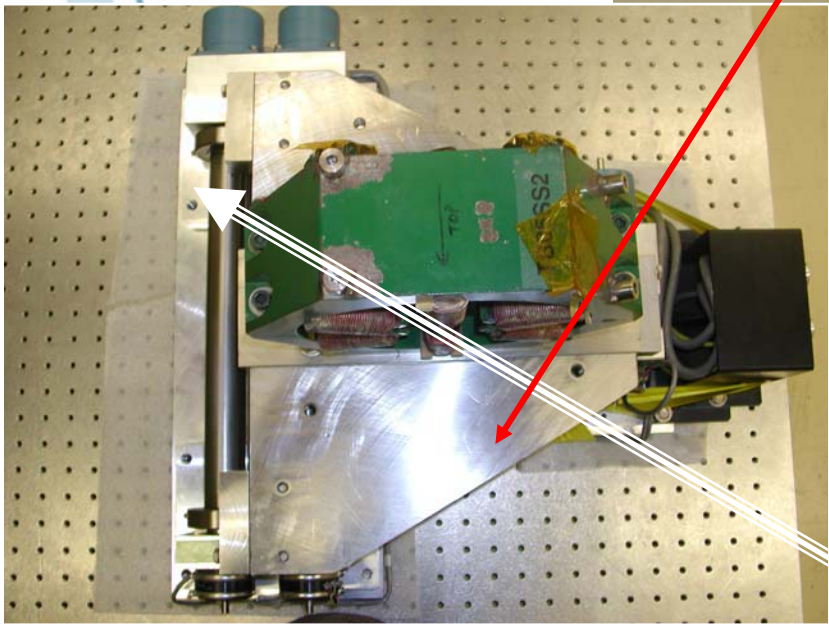
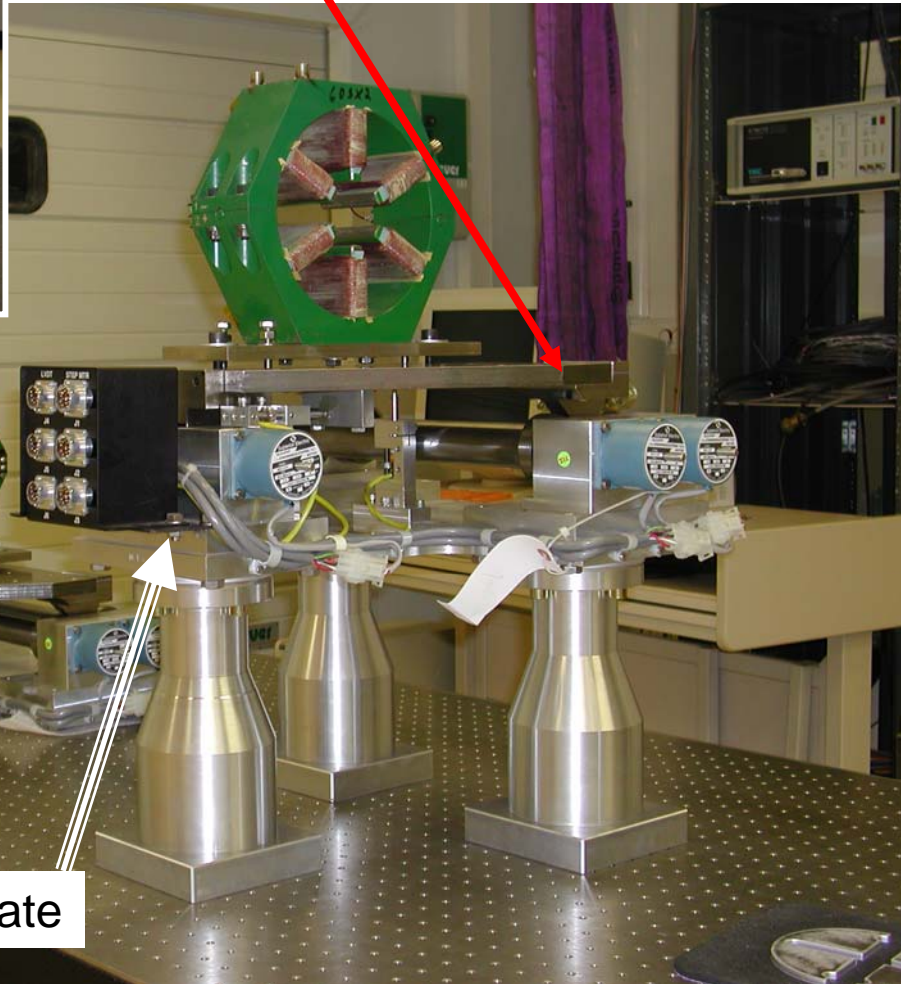

T-plate

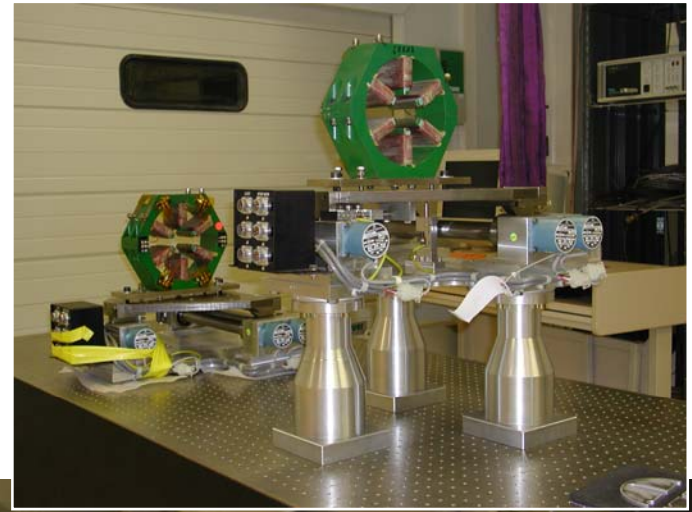

FD configuration (T.Okugi's presentation)

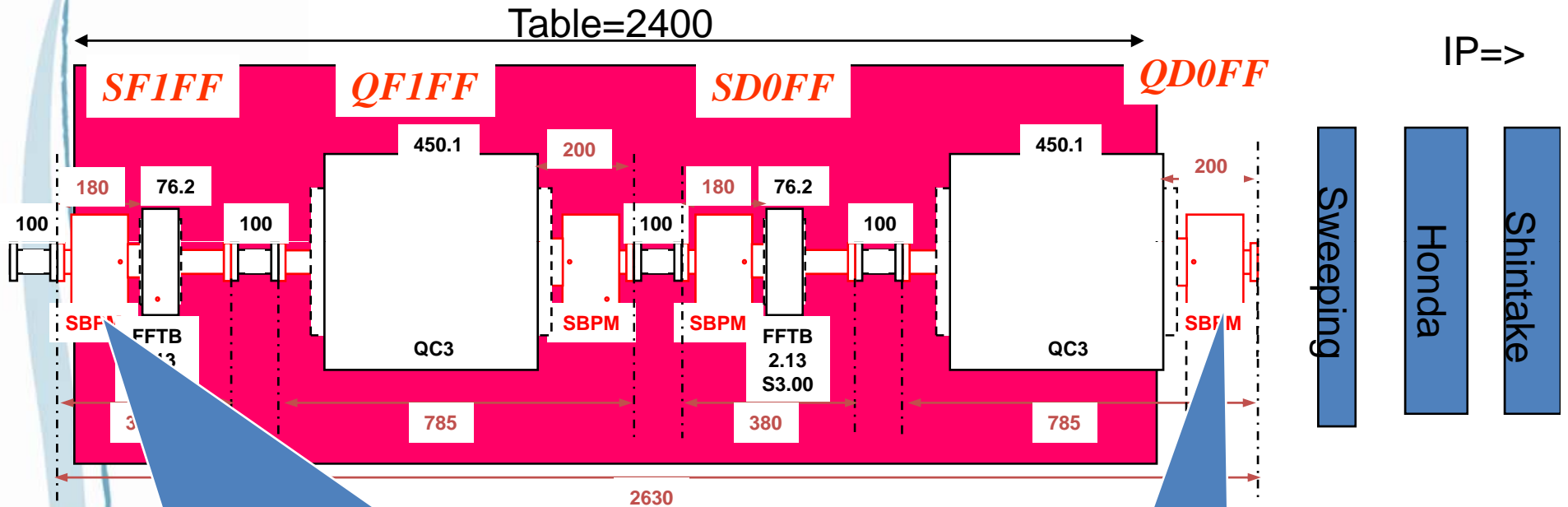

S-band BPM slightly outside table on a "light" Sextupole=> how will the S-band BPM be supported?

Does this BPM need to be supported?

We must make the S-band BPM support adopter for SF1 and SD0, because the weight of S-band BPMs are heavy.

Example of the BPM support

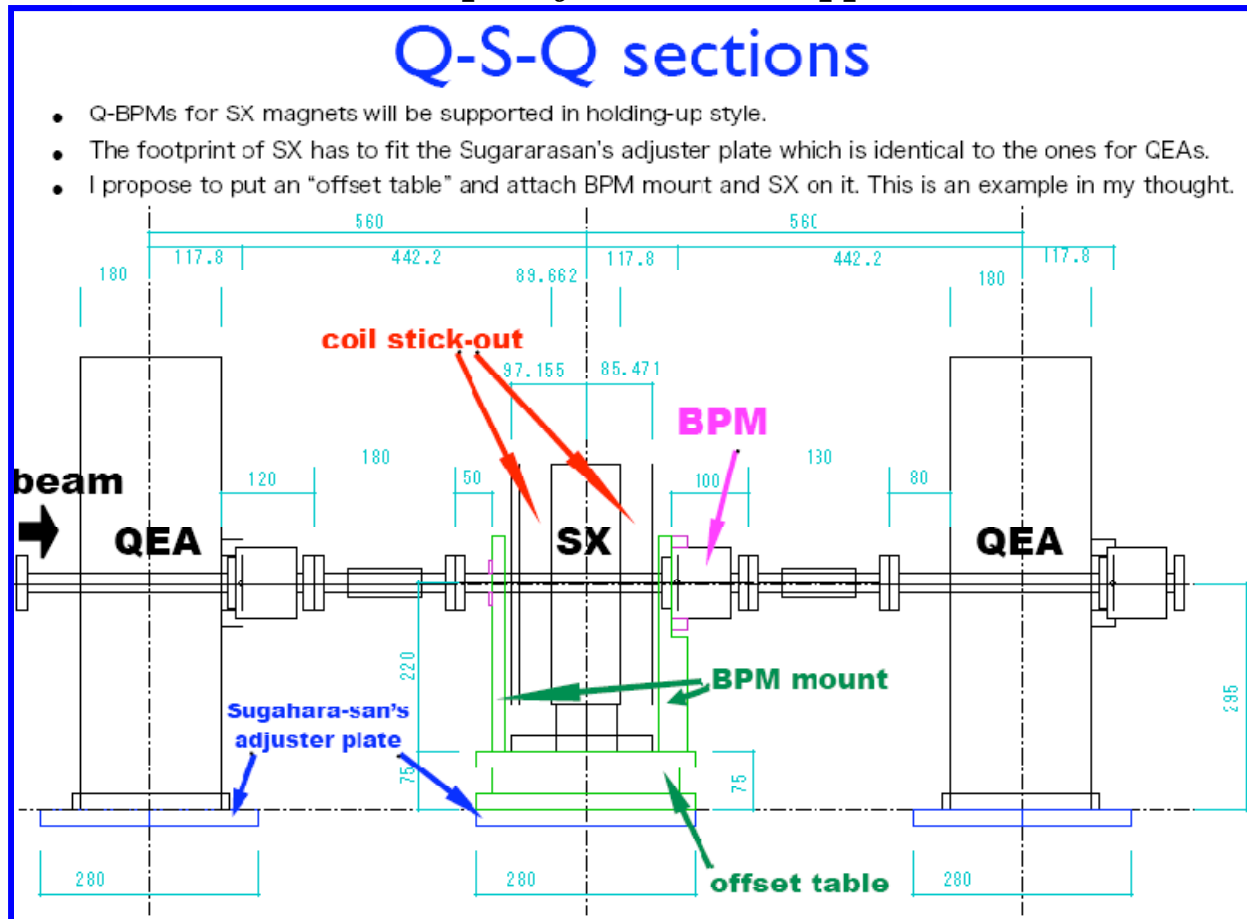

This is not the supports for SF1 and SD0

Compensate the height to reach beam height

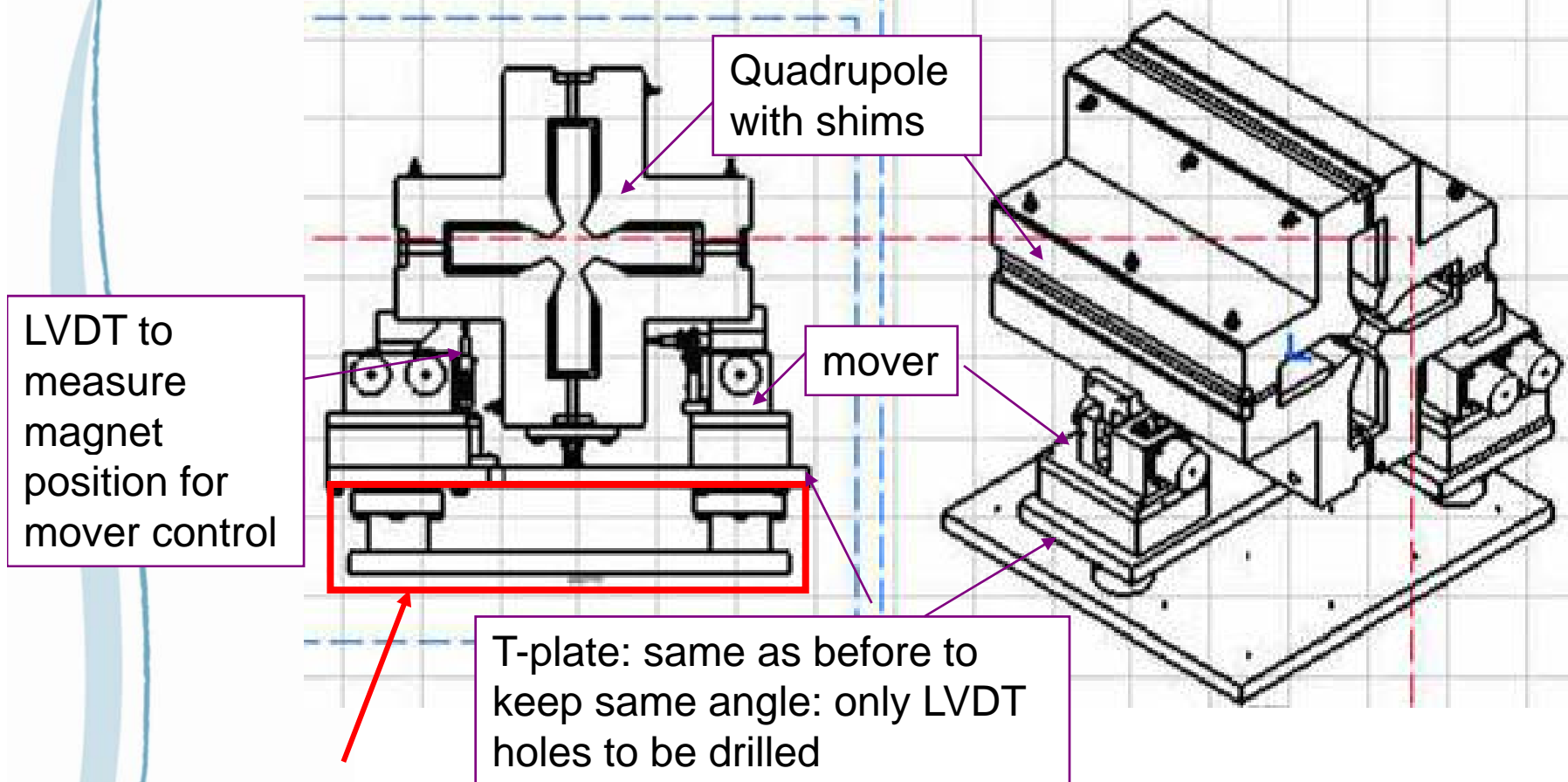

Change the way the mover is fixed on the table



Laboratoire d'Anecy-le-Vieux
de Physique des Particules

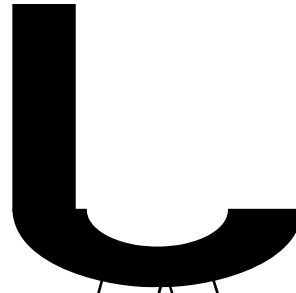

sling

table

room for bolting

beeswax

3 plates



**Set-up can be moved
in the future**

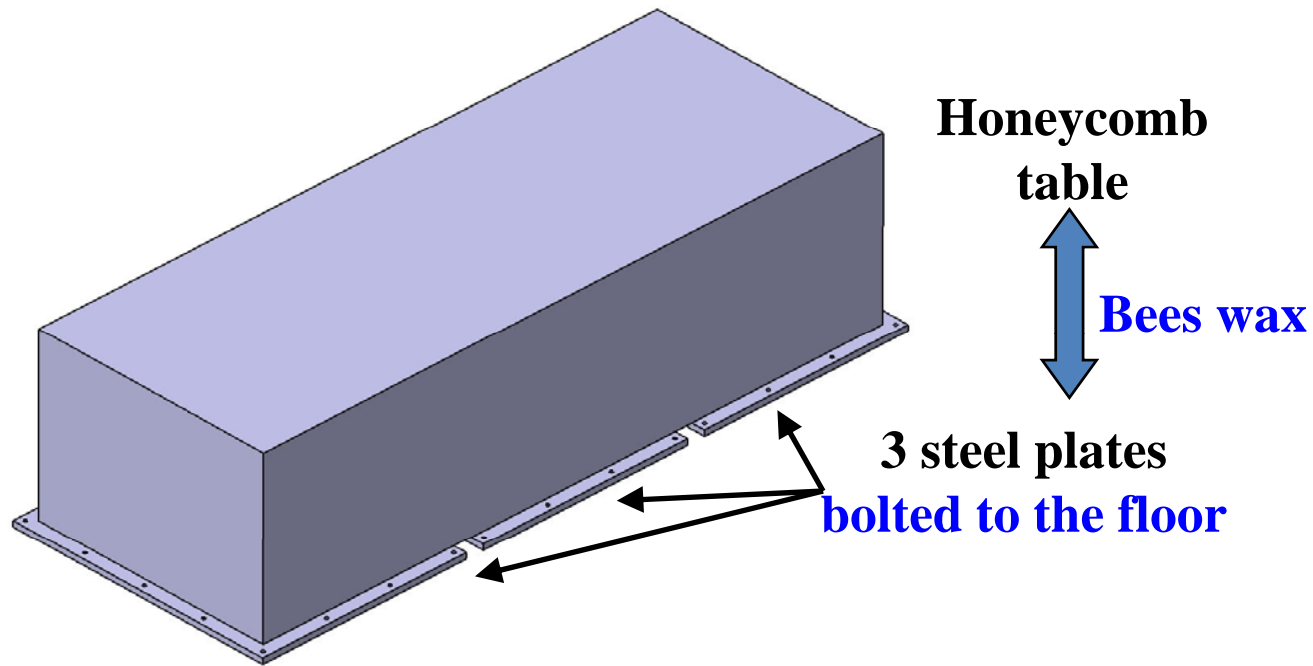

**Bees wax: can be unglued, stable in
time, good transmission of vibrations**