



High-Q cavities measurements and diagnostics at INFN-LASA

Michele Bertucci

Outline

- High Q activities at LASA
 - Current activities: PIP-II project
 - LASA VT cryostat status
 - Cryostat magnetic improvements
 - Future R&D activities
- Cavity diagnostics for high-Q measurements
 - Thermal breakdown
 - Field emission
 - Magnetic sensors
 - Measurements on PIP-II multi-cell prototype **B61-EZ-002**
- Conclusions

INFN in-kind contribution to PIP-II

INFN LASA provided a *novel RF design for the LB650 cavities*, compliant to Fermilab technical interfaces and specifications

INFN-LASA contribution will cover the needs of LB650 section:

- **2 proto cavities** to validate processing and tech. transfer
- **38 SC cavities** required to equip 9 cryomodules with 2 spares, delivered as **ready for string assembly**.
- **Qualification** via vertical cold-test provided by INFN through a **qualified cold-testing infrastructure** acting as a subcontractor
- **Compliance to the PIP-II System Engineering Plan**

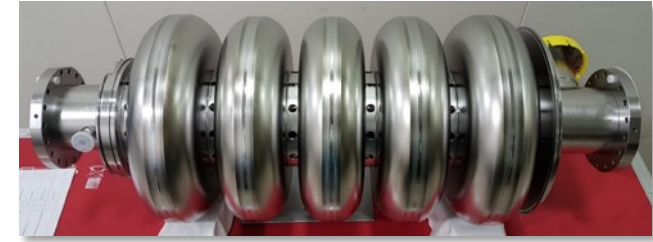

PIP-II LB650 Project Specifications	
Acc. Gradient	16.9 MV/m
Q_0	$2.4 \cdot 10^{10}$
RF rep rate	20 Hz to CW
Beta	0.61

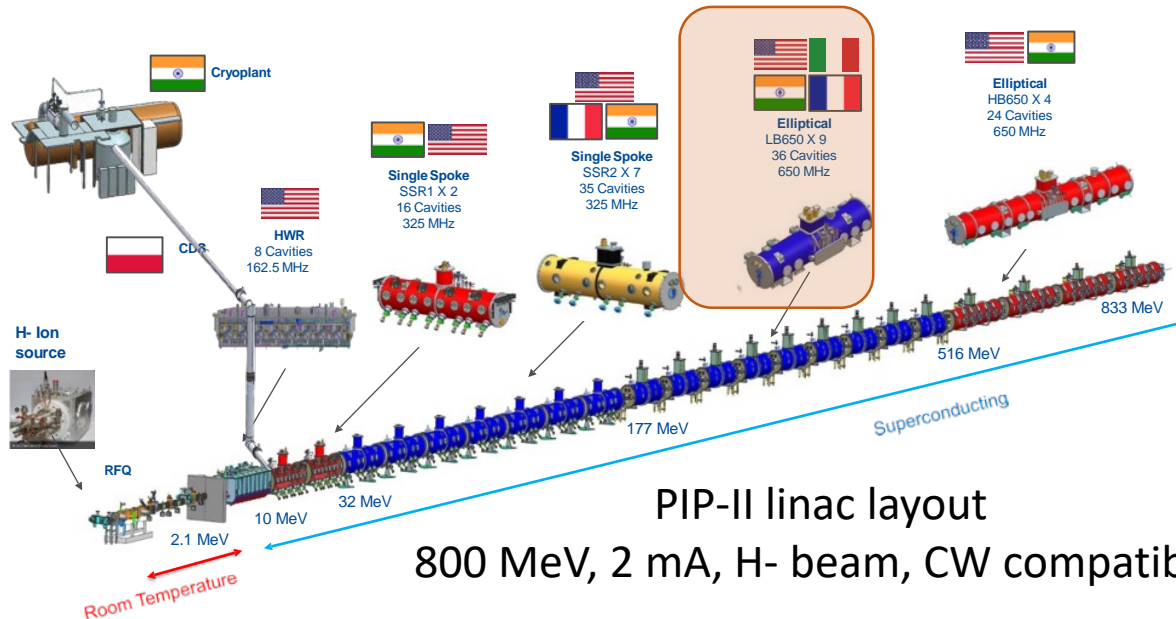

INFN Deliverable Components	Acceptance Early Date
LB Jacketed Cavities (Batch 1 - Qty 4) and Pre-Series (Qty 2)	Jun-2025
LB Jacketed Cavities (Batch 2 - Qty 4)	Aug-2025
LB Jacketed Cavities (Batch 3 - Qty 4)	Oct-2025
LB Jacketed Cavities (Batch 4 - Qty 4)	Dec-2025
LB Jacketed Cavities (Batch 5 - Qty 4)	Feb-2026
LB Jacketed Cavities (Batch 6 - Qty 4)	Apr-2026
LB Jacketed Cavities (Batch 7 - Qty 4)	Jun-2026
LB Jacketed Cavities (Batch 8 - Qty 4)	Sep-2026
LB Jacketed Cavities (Batch 9 - Qty 4)	Oct-2026



LB650 on-going activities at INFN

R&D towards high Q_0 and preparation for transfer to industry

- Prototypes to **develop proper surface treatments**
- B61-EZ-001 jacketed and tested at FNAL
- **B61-EZ-002 jacketed and tested at LASA** →
- B61S-EZ-001 single cell treated and tested at FNAL
- B61S-EZ-002 treated, jacketed and tested at LASA
- **B61S-EZ-003 single cell processed and tested at LASA**
- Prepare **LASA test station for high Q_0 measurements**
 - Lower residual magnetic field, Helmholtz coils
 - Diagnostics to understand performance limitations



B61-EZ-002 - Naked vs. Jacketed VT

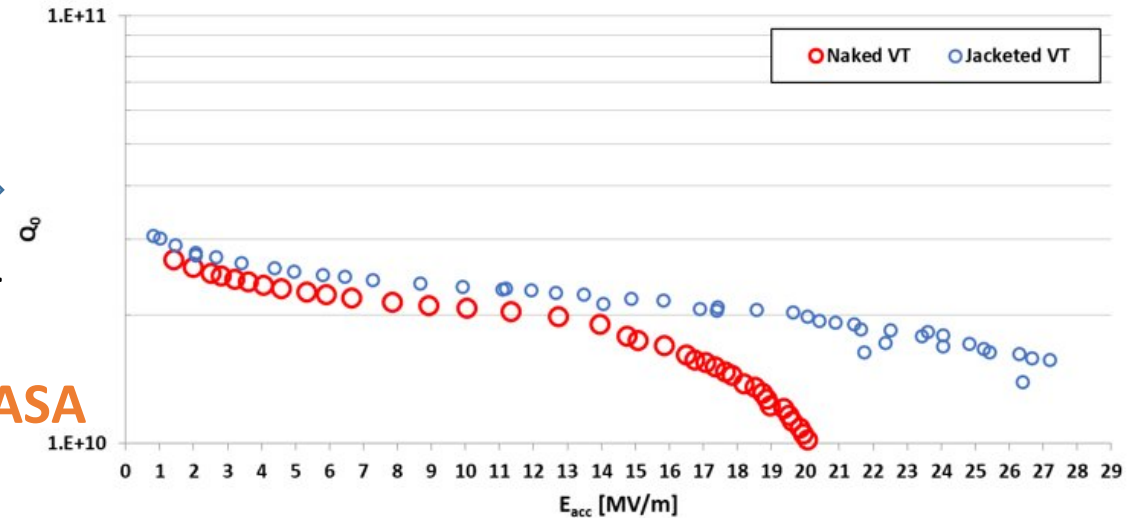

Mid-T bake recipe (3h @300°C)

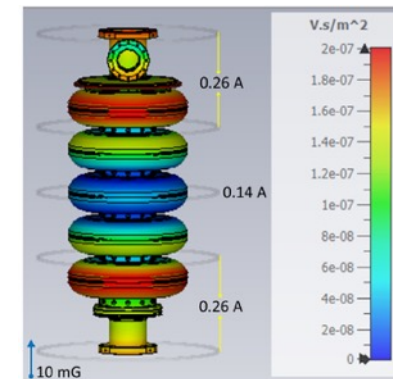

The INFN LASA vertical test facility

RF system for 650 MHz cavities:

- 650 W UHF power amplifier
- Input power coupled by high-Q antenna ($Q_I = 10^{10}$)
- Transmitted power measured by pickup antenna with $Q_{ext} = 3 \cdot 10^{11}$
- PLL to lock cavity frequency (due to high-Q, cavity bandwidth is <0.1 Hz)

Cryostat: ϕ 700 mm, 4.5 m length, losses < 1 W @ 4 K

- Can host $f > 500$ MHz cavities
- temperature sensors, He vapor pressure reading to control He-bath temperature, LHe level probes so to monitor LHe transfer
- Approximately 2500 liters of LHe @1Atm needed to cover PIP-II cavity@2K (32 mbar)

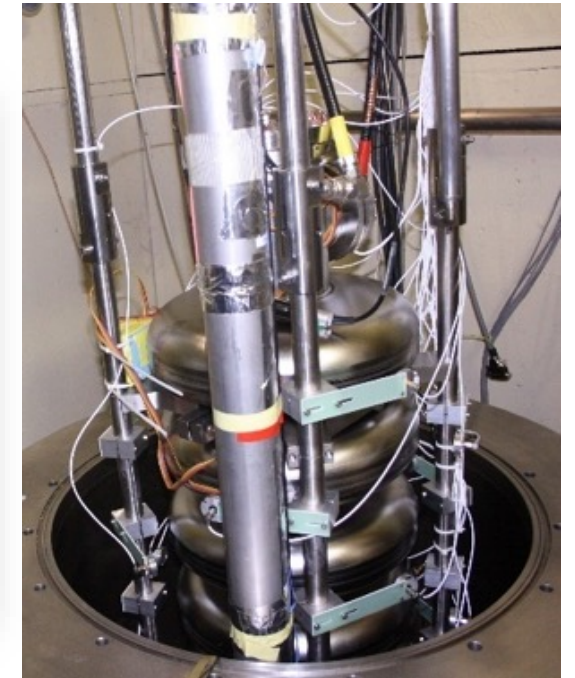
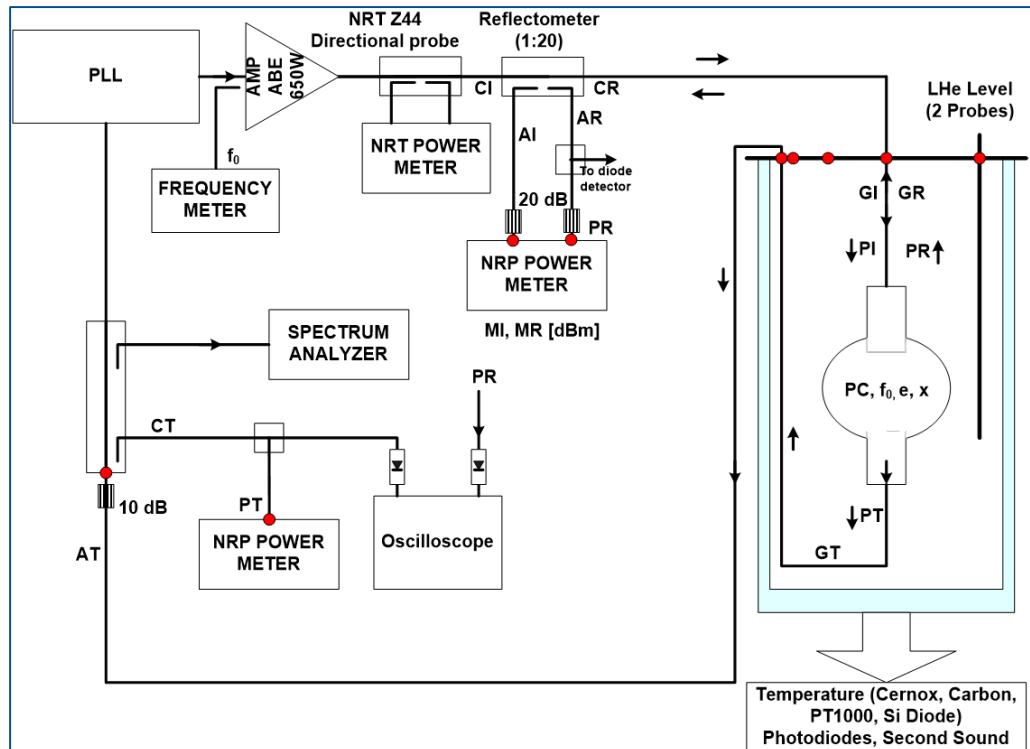

LASA INFN VTS flux expulsion scenario

- **Sub-cooling system:**
 - Cooling power: $\sim 70 \text{ W @ 2 K}$
 - Lowest temperature **1.5 K**.
 - Cooldown rate now limited to about **1 K/min**
- **Residual field:**
 - With mu-metal inner shield: $B_{res} < 10 \text{ mG}$
 - with cryoperm shield: 5 mG max expected

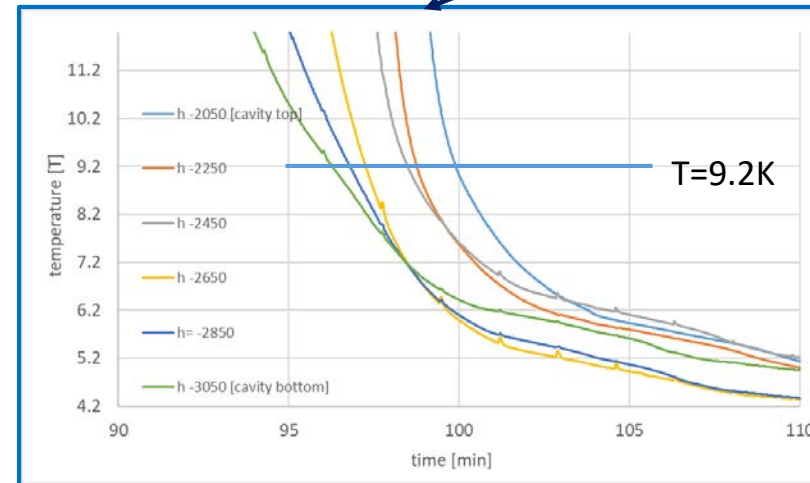
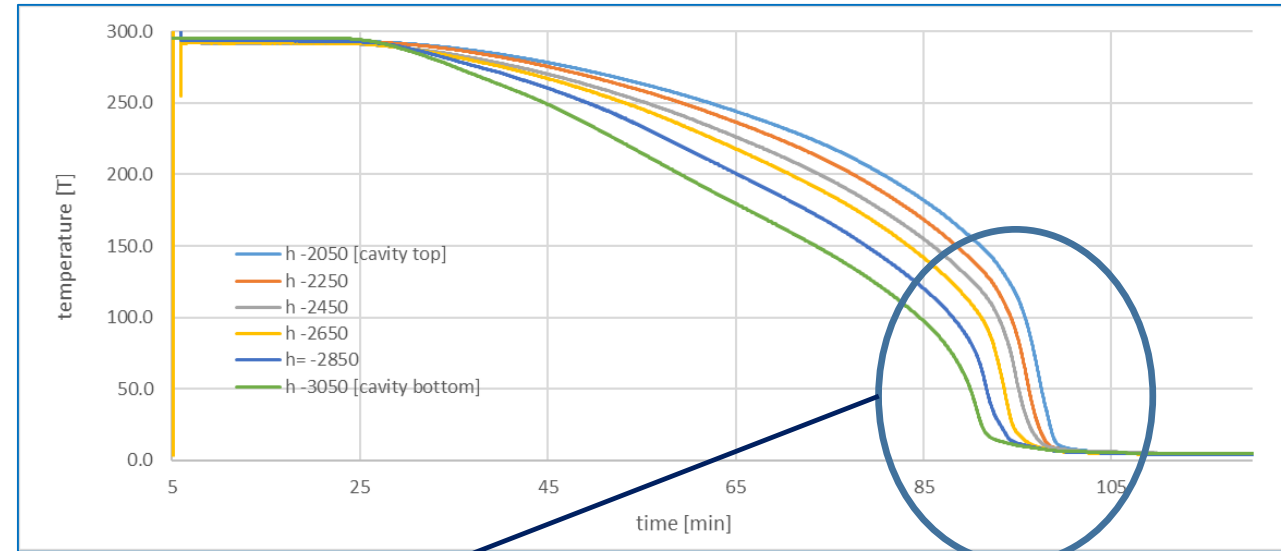
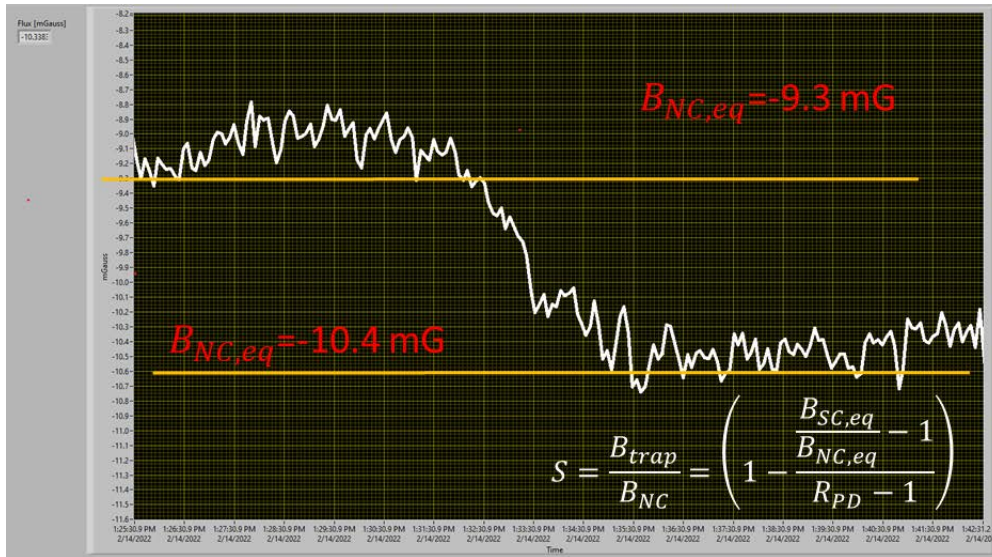

T sensors during
cooldown (h=height)
Around 9.2K:

- \dot{T} is $< 1 \text{ K/min}$
- ∇T of some K/m

**LHe trasferred from
cavity bottom**

Typical trapped flux efficiency $S = \frac{B_{trap}}{B_{NC}}$ of the order 87%

assuming $0.4 \text{ n}\Omega/\text{mG}$ for baked niobium at 650 MHz: $R_{t.f.} = 4 \text{ n}\Omega$ trapped flux residual resistance

How to improve the cryostat for high-Q?

$$Q_0 = \frac{G}{R_s(T)}$$

- G is a geometry factor and depends only upon cavity geometry
- R_s cavity surface resistance, depending on rf frequency, temperature and material parameters (penetration depth, electron mean free path, coherence length, bandgap)

$$R_s(T) = R_{BCS}(T) + R_{t.f.} + R_0$$

$R_{t.f.}$ is the contribution of trapped magnetic flux and can be minimized with dedicated magnetic hygiene protocols.

Trapped flux efficiency: depends upon ∇T across cavity length. Can be reduced with improved design of LHe-transfer lines, and employing local heaters to offset the temperature level

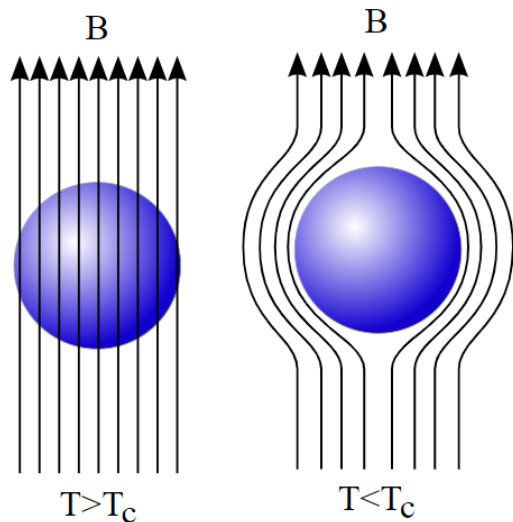

$$R_{t.f.} = \eta \cdot S \cdot B$$

Trapped flux sensitivity: depends upon material and treatment history. Can be reduced by optimizing cavity treatment (annealing and final baking temperatures)

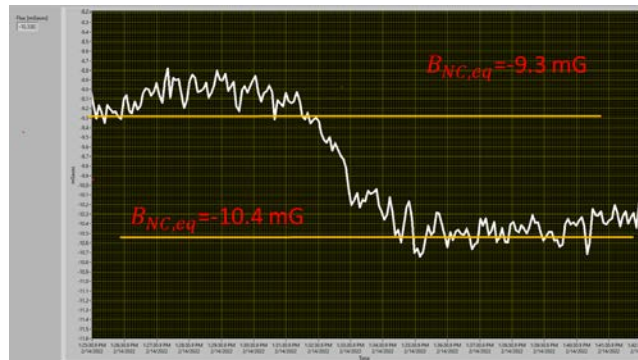

External magnetic field: depends upon shielding efficiency. Can be reduced resorting to Helmholtz coils for active field cancellation

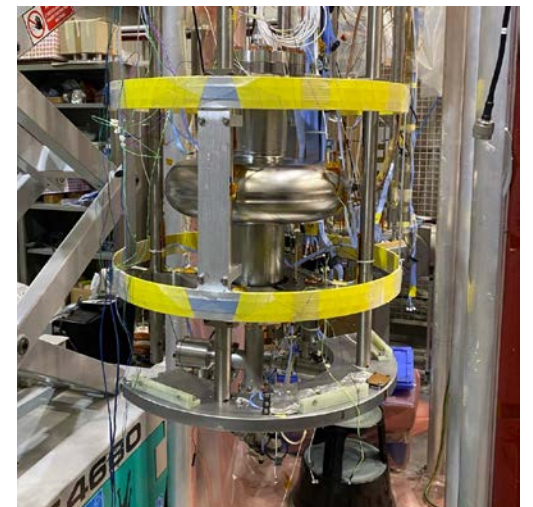

Helmholtz Coils for field cancellation

- **Active cancellation strategy:** $R_{t f}$ Can be minimized by active cancellation of the external field with Helmholtz coils:

$$B_{tot} = B_{res} + B_{coil}(i) = 0$$

for a given choice of the coil current i , being $B_{coil}(i) = k \cdot i$
with $k \approx 0.7 \text{ mG/mA}$ at eq.

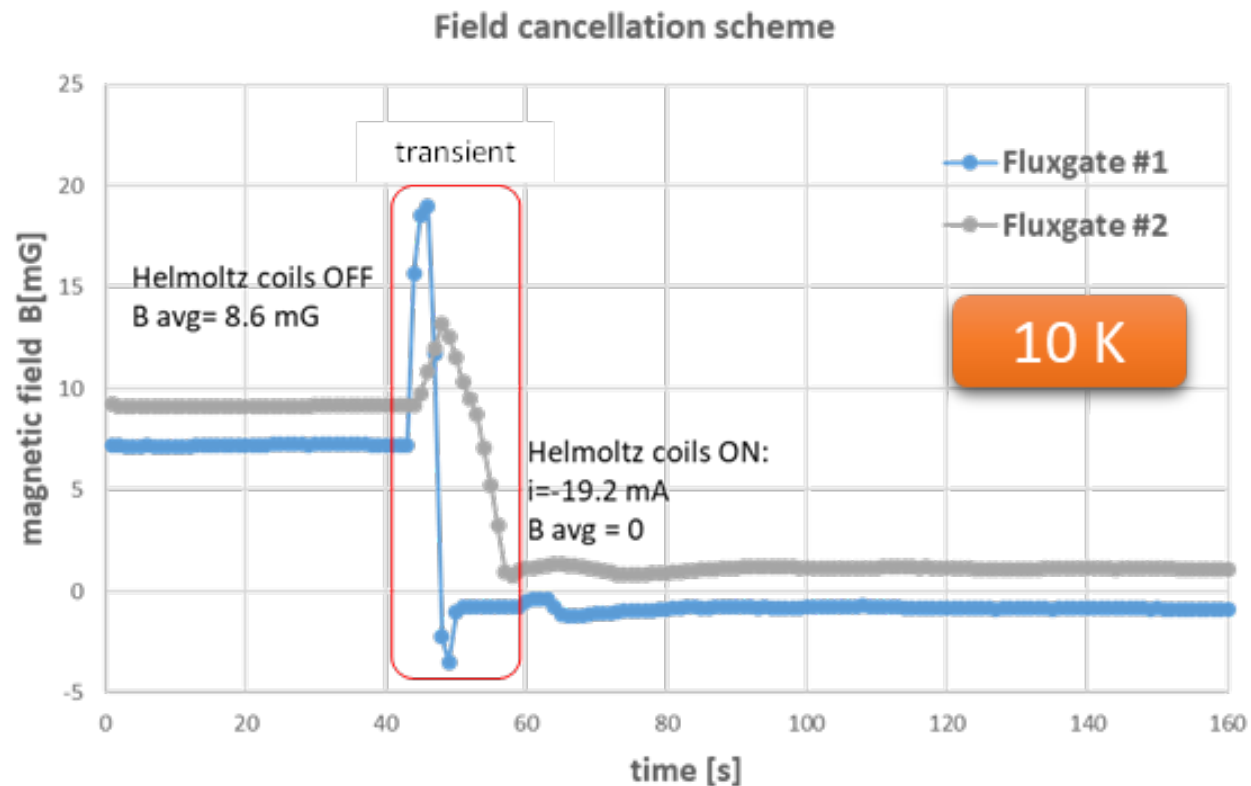

On PIP-II\ESS cavities VT insert:

- 3 Fluxgates + 1 AMR installed on cavity equator
- Average value of field chosen as setpoint for coil
- Near 9.2K, coil is turned on to cancel the field

Test on PIP-II prototype cavity B61S-EZ-003

- Treatment history: 120 um EP + 3h @900°C in UHV + 40 um EP + 3h @300°C (mid-T bake)

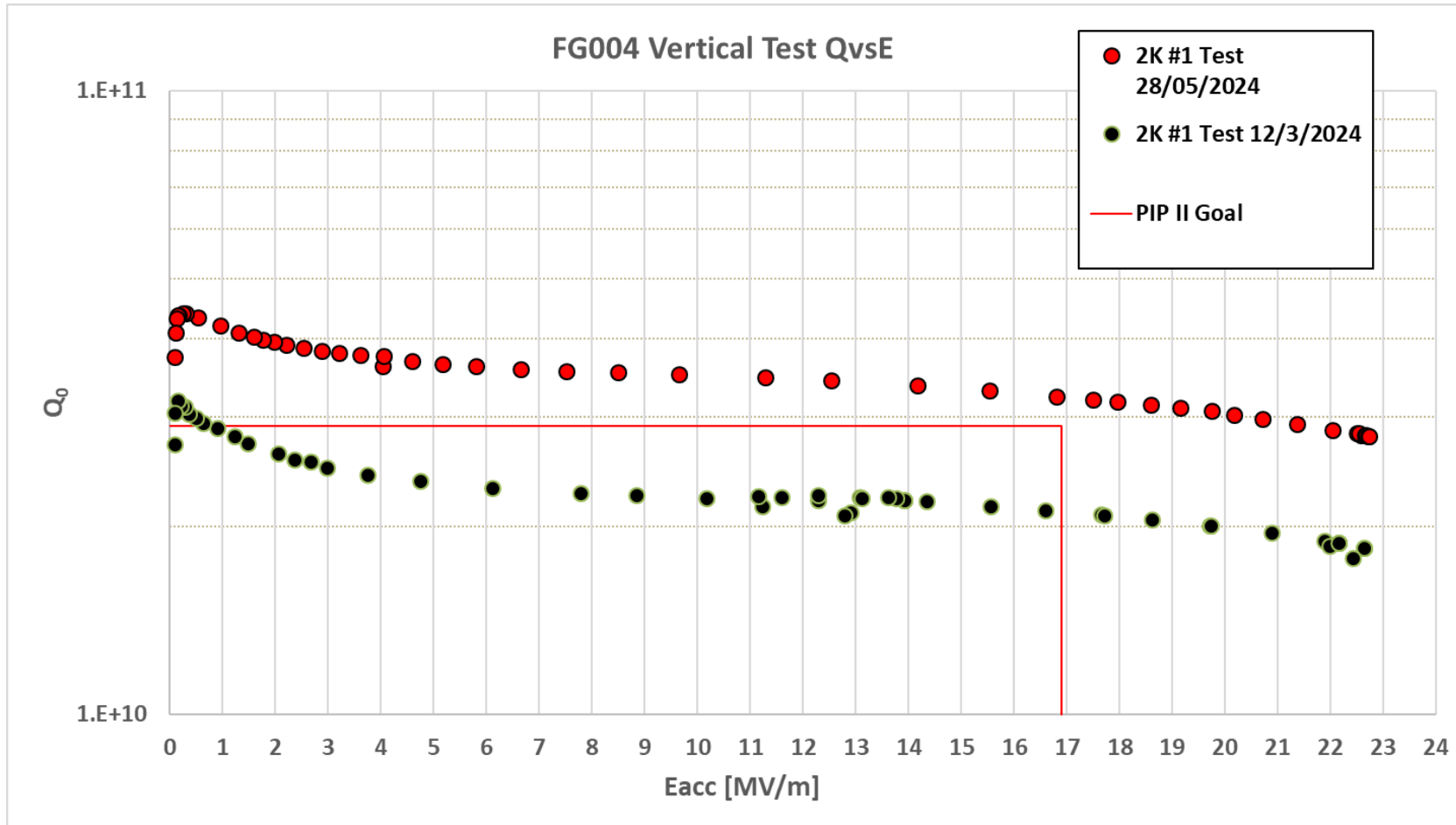

Test #1: error in field cancellation due to SMA cables perturbing Fluxgate readout

Test #2: after cables removal. Efficient field cancellation with correct Fluxgate readout

test	#1	#2
Set field [mG]	-8.6	-4.1
True field [mG]	4.1	4.1
Final field [mG]	-4.5	0

B61S-EZ-003 R_s comparison

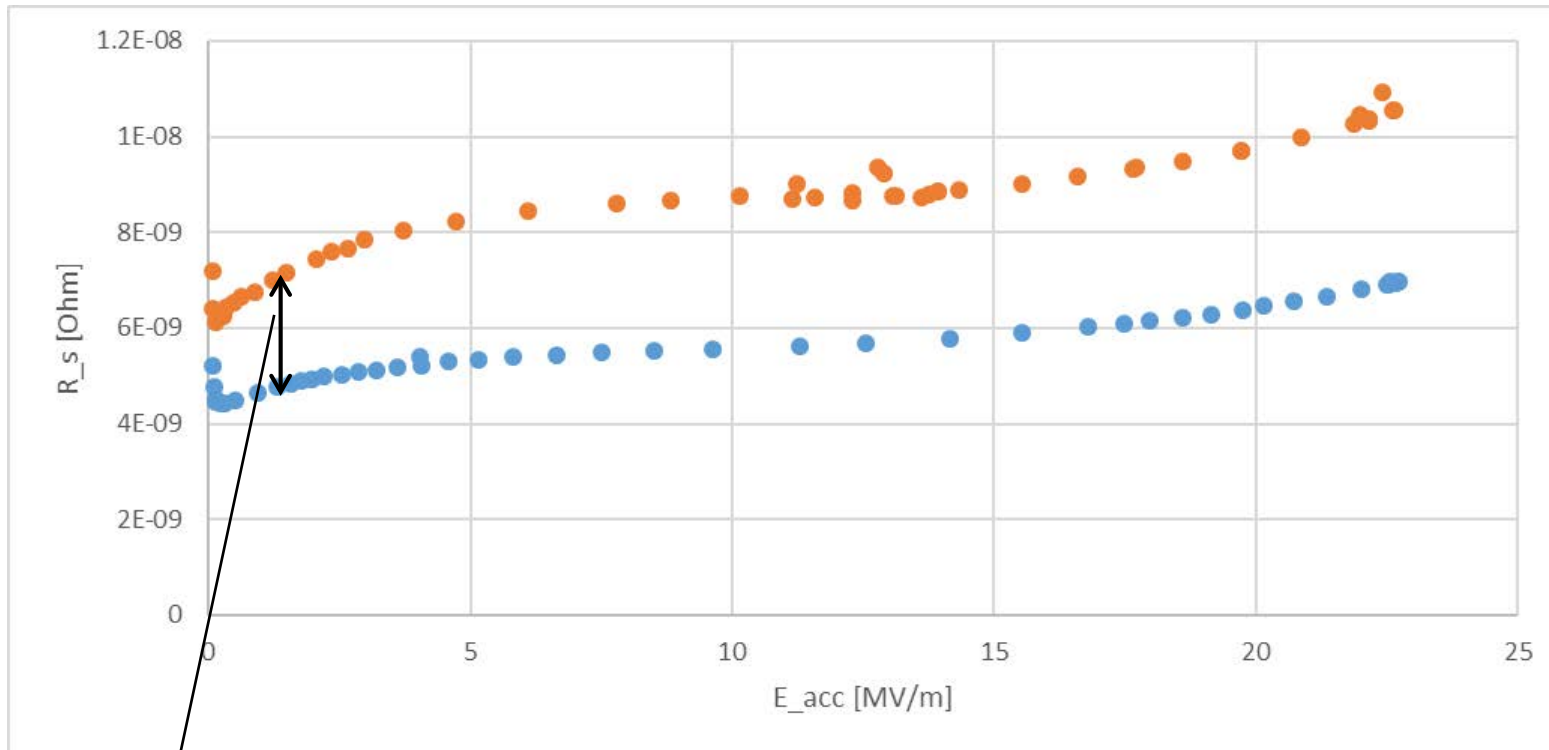

Educated guess: SMA cables magnetization affect the FG reading but not the avg field on cavity

test	#1	#2
Final field [mG]	-4.5	0
Surface resistance [nΩ]	6.5	4.5

$$R(T) = R_{BCS}(T) + R_{mag} + R_0$$

$$R_{mag} = S \cdot B$$

$$\Delta R_s = S \cdot \Delta B = 2 \text{ n}\Omega$$

$$\Delta B = -4.5 \text{ mG} \rightarrow S = 0.44 \text{ n}\Omega/\text{mG}$$

In line with some exp. Findings for mid-T bake (but not all)

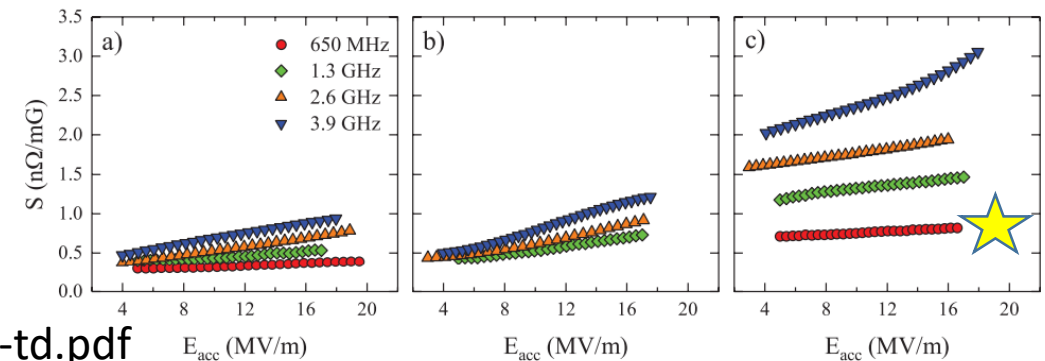

See <https://arxiv.org/pdf/1711.05902> or <https://lss.fnal.gov/archive/2023/conf/fermilab-conf-23-332-pip2-td.pdf>

B61S-EZ-003 Quench at different ext. fields

For a quench in an external field B, the expected increase in residual resistance is:

$$R_{mag} = a \cdot S \cdot |B|$$

where a is a surface ratio (quench surface/overall RF surface)

Measurement protocol

while i:

- An external B_i is set with coils with RF OFF
- RF ON: Cavity power rise until a quench occurs
- A part of cavity surface goes NC from SC
- B_i is trapped in this region, changing residual resistance to $R_s(i) = R_0 + R(i) = R_0 + a \cdot S \cdot |B_i|$
- RF turned OFF
- $i = i+1$

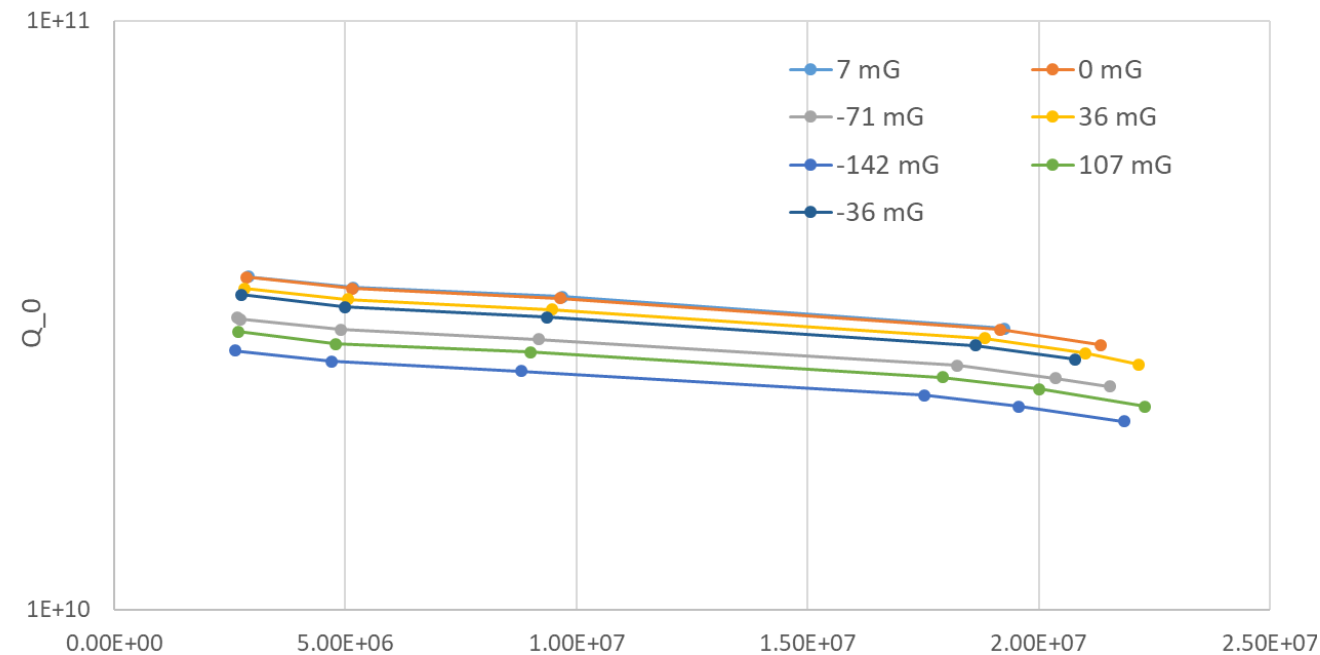
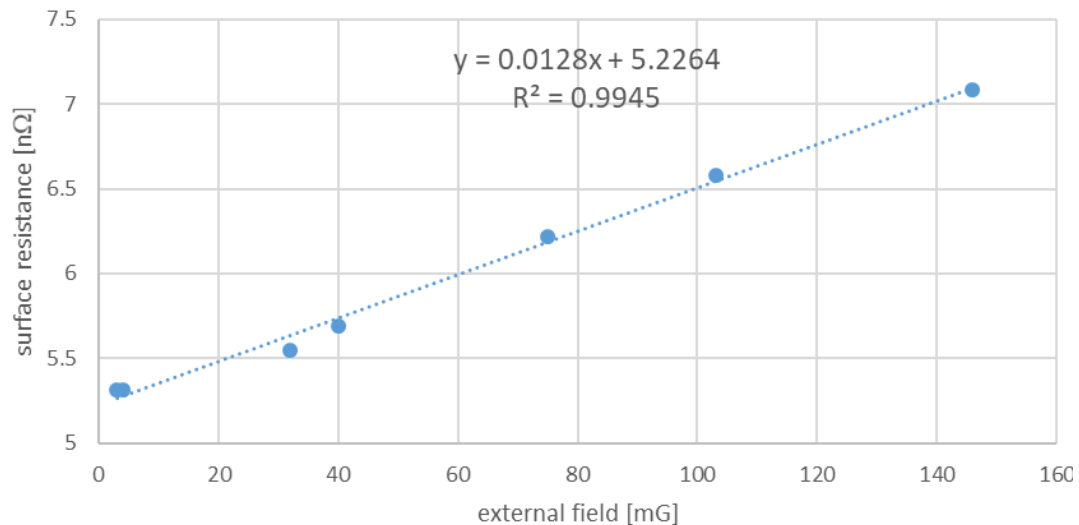

$a \cdot S$ [nΩ/mG]	S [nΩ/mG]	a
0.01	0.44	0.03

Quench area is about 3% of total RF active area

INFN High-Q/High-G R&D activities

INFN LASA is involved in several R&D international projects:

- **ILC Technology Network (ITN)** derived from ILC IDT (ILC International Development Team) to support pre-lab technological priorities as identified by the International Expert Panel
- **EAJADE** Staff exchange network for accelerator R&D within elementary particle physics
- INFN-funded R&D activity in the framework of **European Strategy for Particle physics**

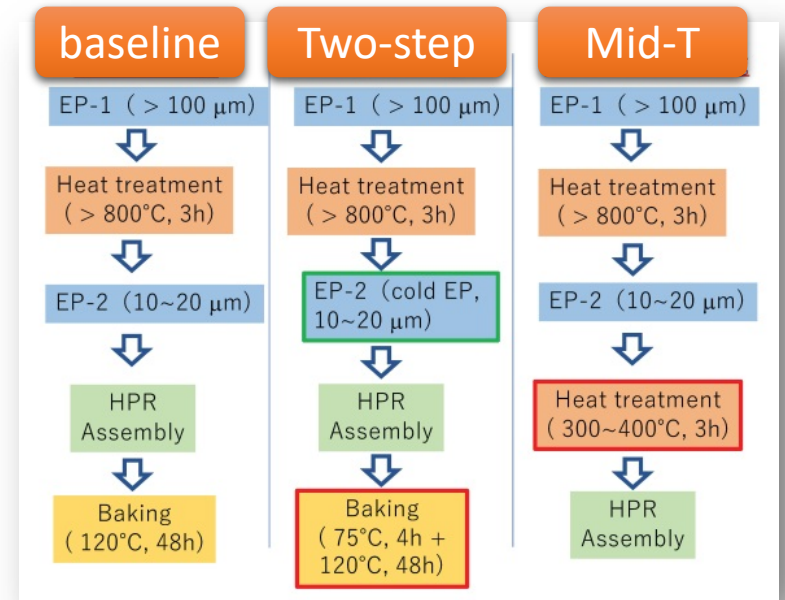

Foreseen activities(3 years):

- **Surface treatments** development for reaching High-Q/High-G performances (single-cells)
- **Industrialization:** from single to multicell cavity
- **R&D on cavity ancillaries** (tuner, magnetic shield, etc,)

R&D for High-Q/High-G cavities :

- 1-cells 1.3 GHz: **surface and thermal treatments** development & qualification
 - E-XFEL (baseline), Mid-T, two-step baking
 - Cold VT (qualification) at LASA and in other labs (results validation)
- A new testing Cryostat for high-Q cavities is under development

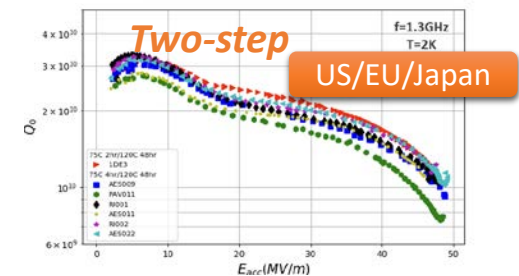
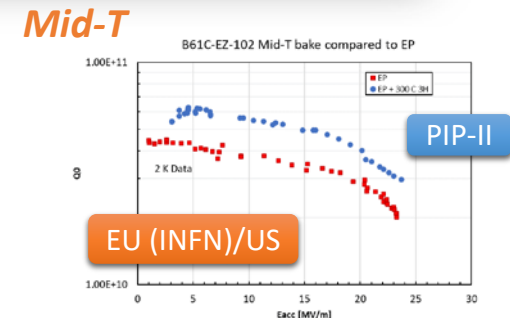
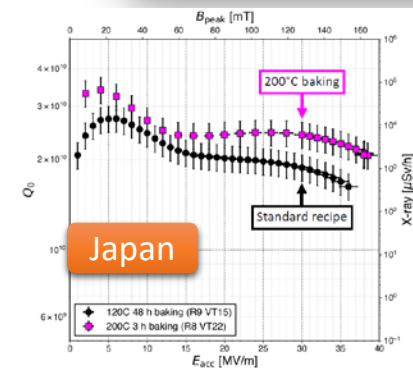

New cryostat

Cryostat and ancillaries

- **Dedicated «small» cryostat**

- L = 3000 mm, OD 610 mm, max. cold volume 250 l
- 1.3 GHz cavities (two single-cell/one 9-cell)
- Short cold test cycle
- ¼ of the Lhe required (w.r.t large cryostat)

- **Cryostat insert**

- Cavity installation and removal optimized

- **External magnetic shield**

- Available and qualified
- Bottom part will be re-annealed after machining (cryostat integration)

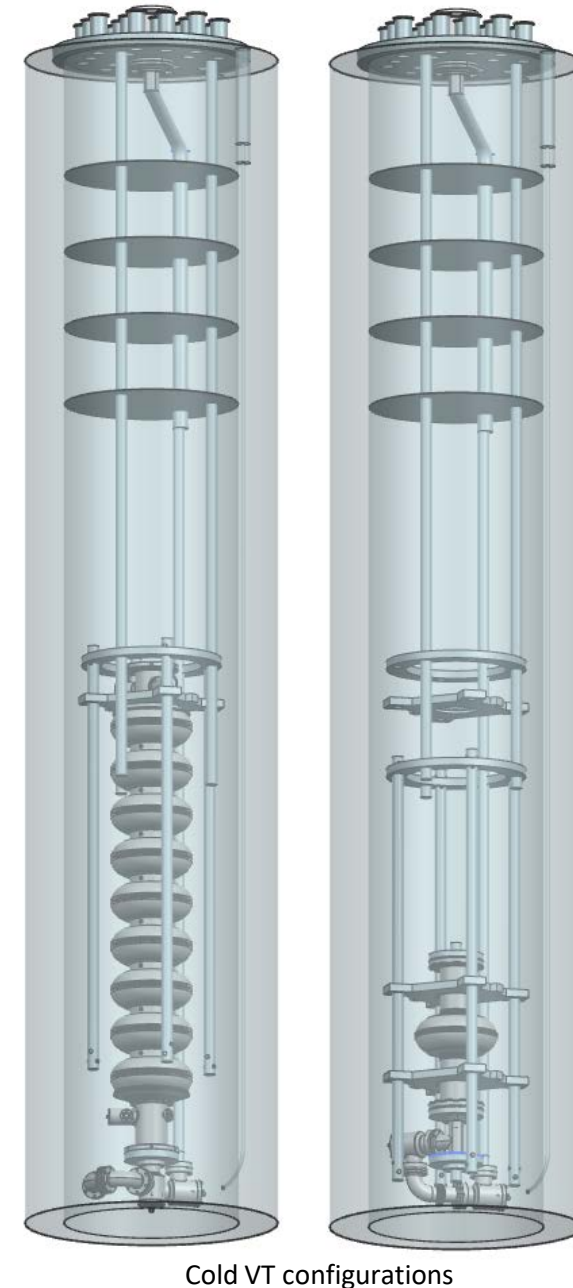
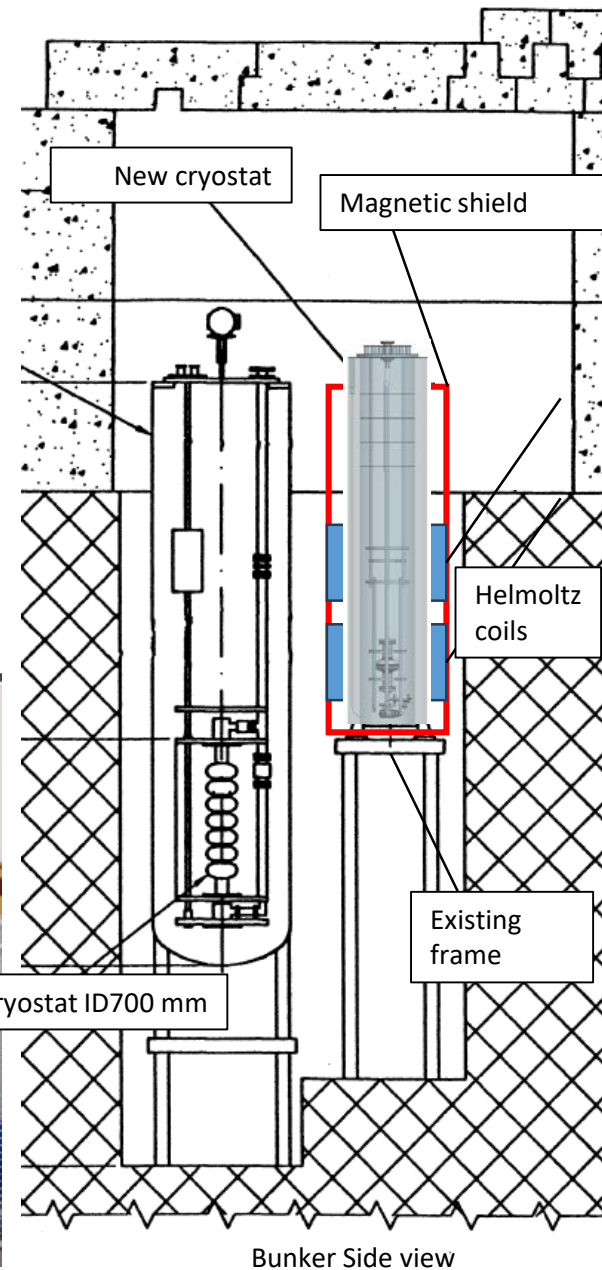
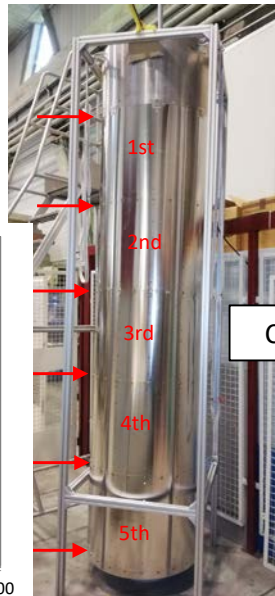
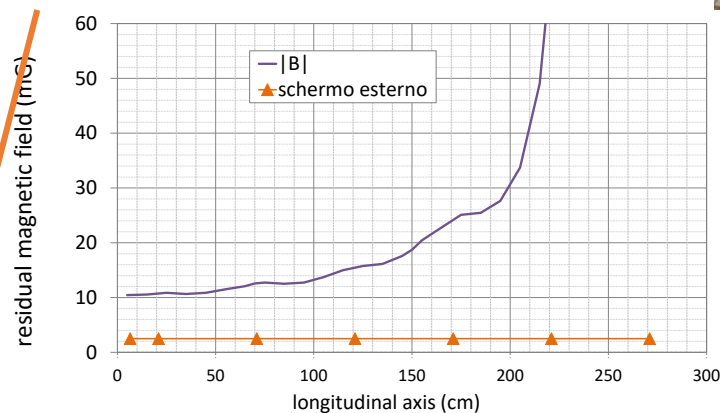

Diagnostics – Thermal breakdown

Second Sound detectors for quench source detection:

- More than 20 **OST** (Oscillating Superleak Detectors) in house developed can be installed inside cryostat
- 20 channels external amplifier provides 90V polarization to sensors and 27 dB gain to sensors signal with a 100 kHz bandwidth.
- Signals are acquired by NI CRio unit, triggered with a digital signal generated from the drop of transmitted power
- Quench position can be calculated by choosing several algorithms of trilateration. Final spatial resolution is limited to 5-10 mm.

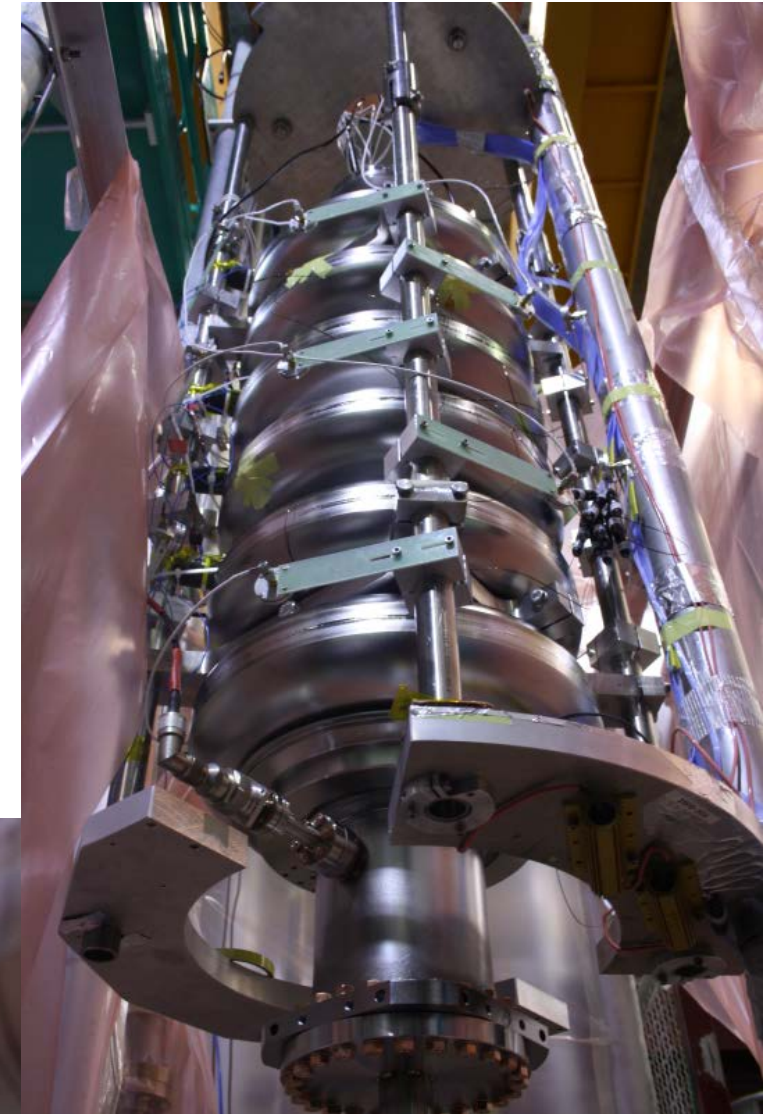
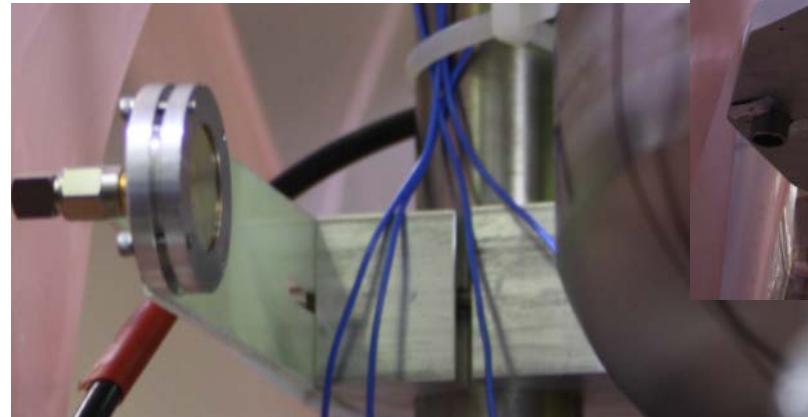
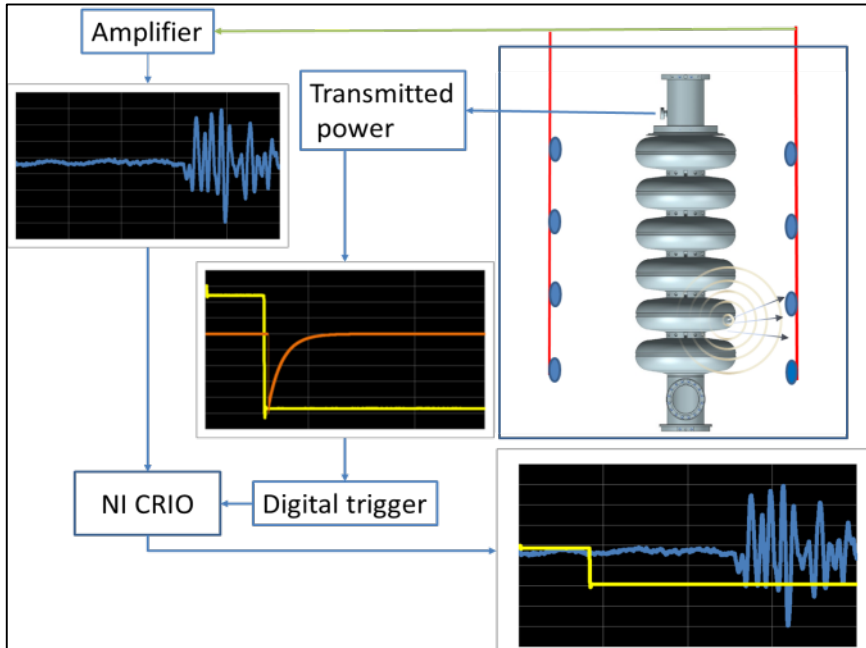

Diagnostics: Magnetic measurements

- 3 cryogenic fluxgates to map magnetic flux across transition
- AMR sensors cross-calibrated through Fluxgates measurement (warm and cold). 3D configuration
- Helmholtz coils to calibrate AMR sensitivity
- Temperature sensors to monitor cavity thermal gradient across transition

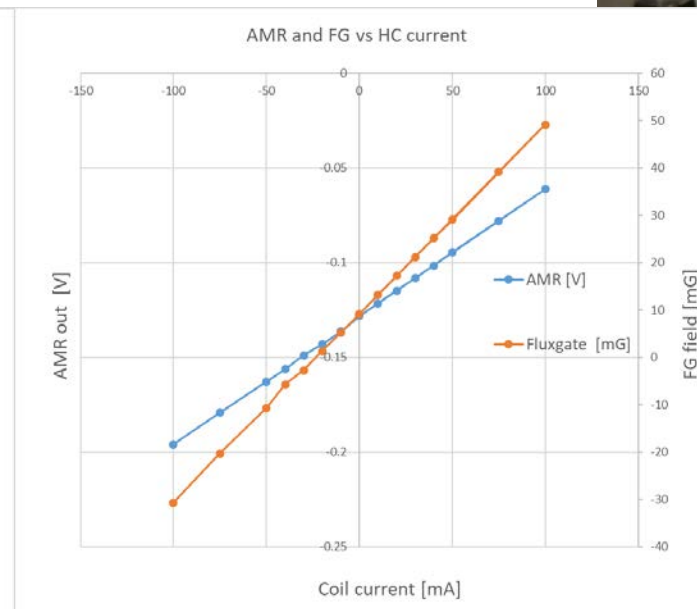
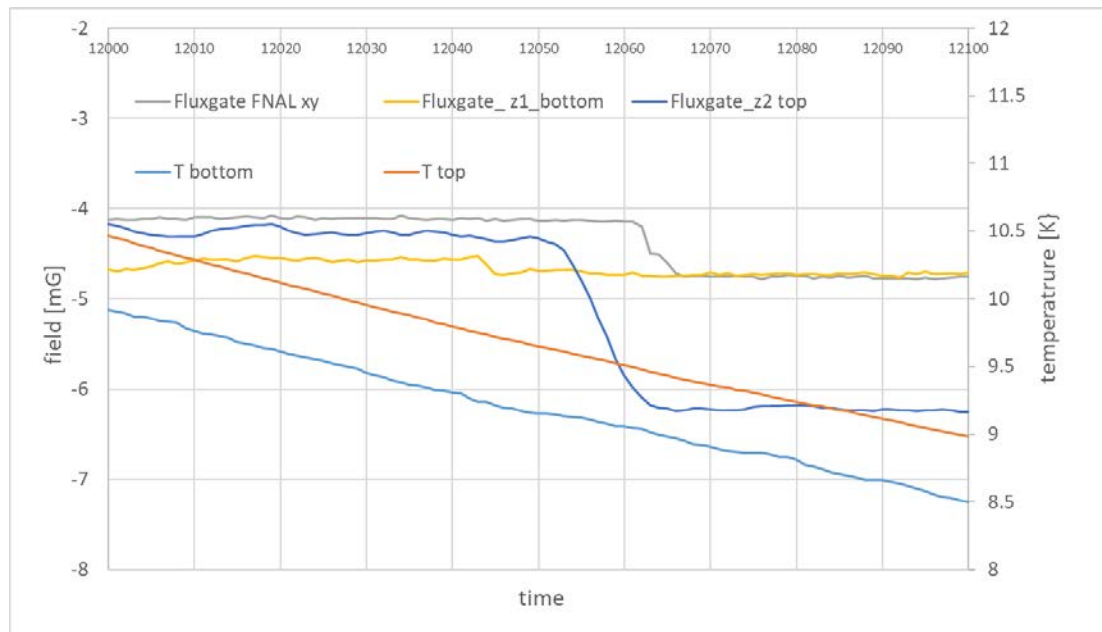
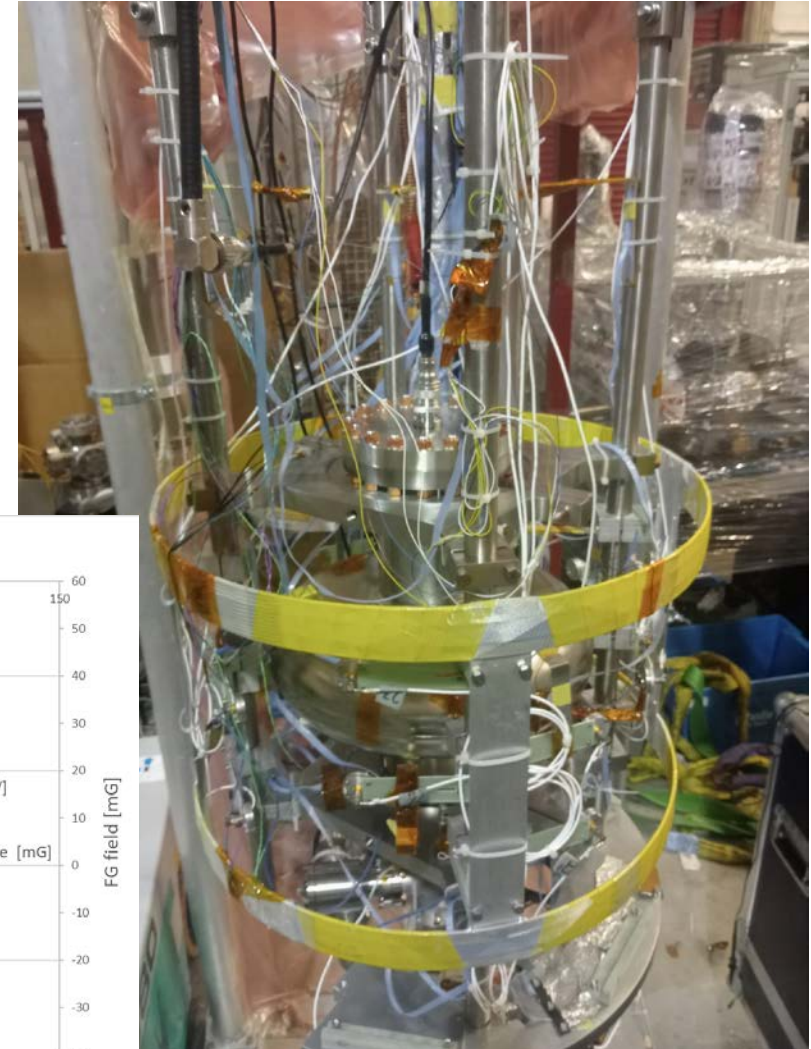

Diagnostics – Radiation

Cryogenic Photodiode detectors

- Allow to localize the FE origin and a direct evaluation of real radiation yield
- S6775 Pin diode (replacing Hamamatsu S1223-01 with magnetic packaging)
- Amplifier boards are placed nearby the diode so that pick-up noise from cables is minimized. All the electronics is suitable in the cryogenic context (CMOS based op-amps, metal film capacitors,...).
- Sensors signals are extracted from cryostat and collected by a NI DAQ unit. Now a maximum of 28 sensors can be installed in the cavity frame.



External radiation detectors on top cryostat cover only, close to cavity axis

- **Gas-filled (Xe) proportional counter** (Thermo Electron FH 40-G) for dose measurement:
 - Measurement range from 100 nSv/h to 1 Sv/h
 - Continuous acquisition every 1 sec.
 - Energy range from 45 keV to 1 MeV → poor sensitivity for higher energies
- **NaI(Tl) scintillator** (Ortec 905-3) for measuring X-ray spectrum
 - Maximum count rate 10^6 counts/sec
 - Energy range from few keV to 10 MeV
 - Due to its high sensitivity to radiation, for high doses detector saturates producing counts pile-up: screening with high Z material is needed!

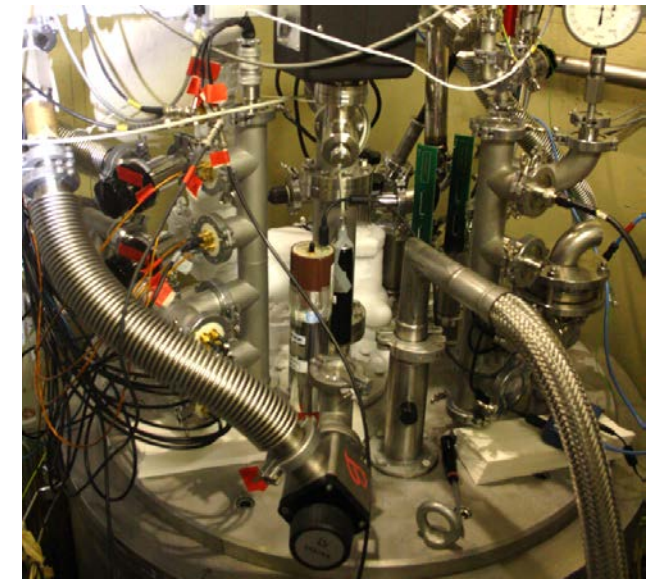

Cavity test: B61-EZ-002 (mid-T bake recipe)

- Slow cooldown (1K/min) across critical temperature (9.2K)
- 5 mG of residual field at cavity equator
- assuming 0.3 n Ω /mG for baked niobium @650 MHz: $R_{fi}=2.4$ n Ω

- 1 $^\circ$ test: some MP with radiation, then sudden rise of radiation at 20.8 MV/m and Q degradation
- Test repeated from low fields
- 2 $^\circ$ test: same behavior as the 1 $^\circ$ test up until 14 MV/m....
- ...then, sudden rise of radiation and drop of Q_0
- Cavity quench at 23 MV/m with FE
- **Irreversible activation of a field emitter!**

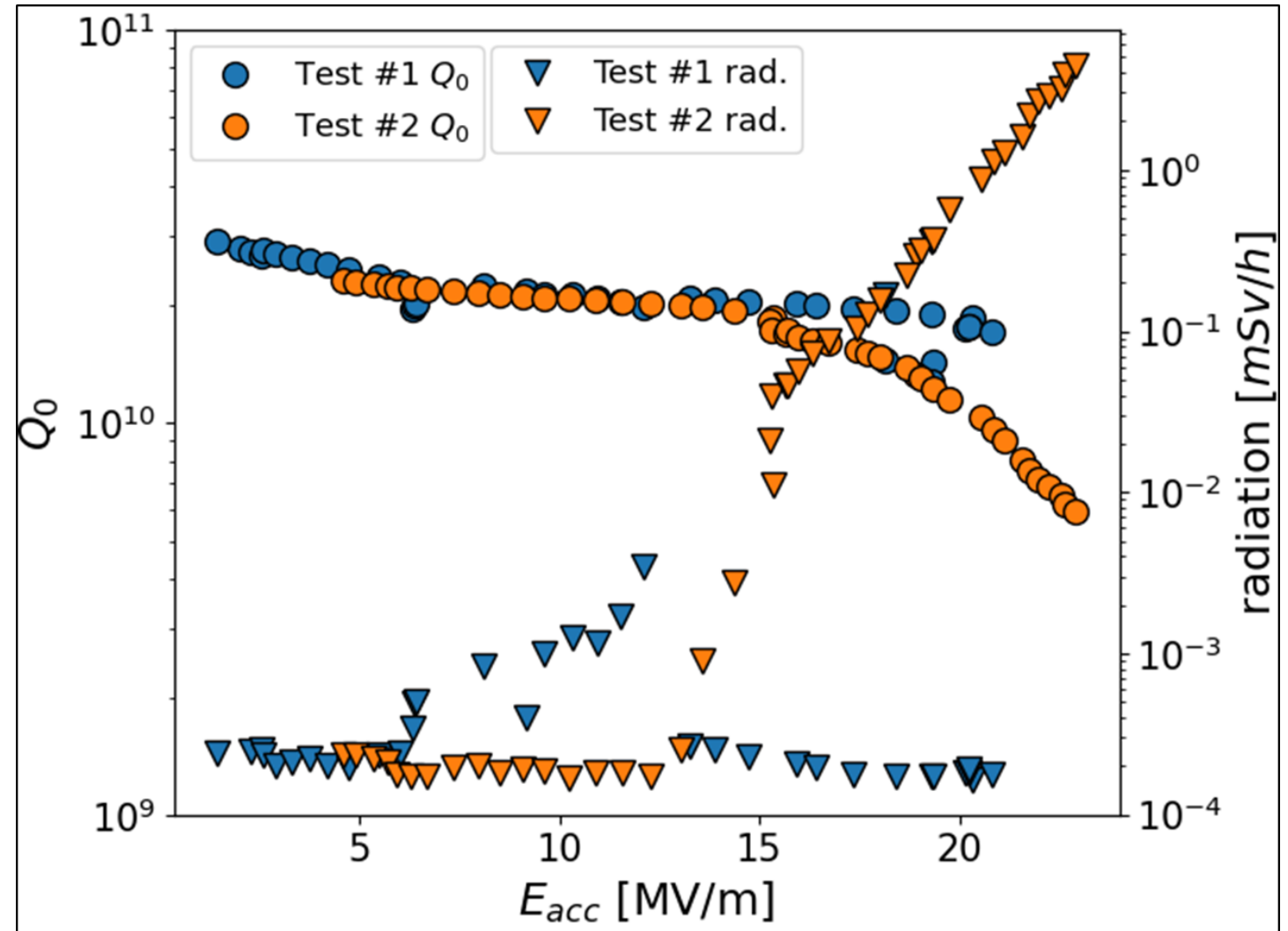

B61-EZ-002 real-time scintillator X-ray spectrum

- Continuous acquisition of X-ray spectrum during power rise
- Electron impact energy as function of E_{acc} obtained by energy end-point extrapolation



B61-EZ-002 Field emission model

- The emitter is modeled by its position on cavity, emitter area S and field enhancement factor β_{FE}
- The Power adsorbed by FE-electrons with impact energy $E_{k,i}$: $P_{FE} = \frac{1}{T_{RF}} \sum_i E_{k,i}$ (sum all over RF-cycle).....

- ...causes a drop in the measured Q according to: $\frac{1}{Q_0'} = \frac{1}{Q_0} + \frac{R/Q P_{FE}}{(E_{acc} l)^2}$

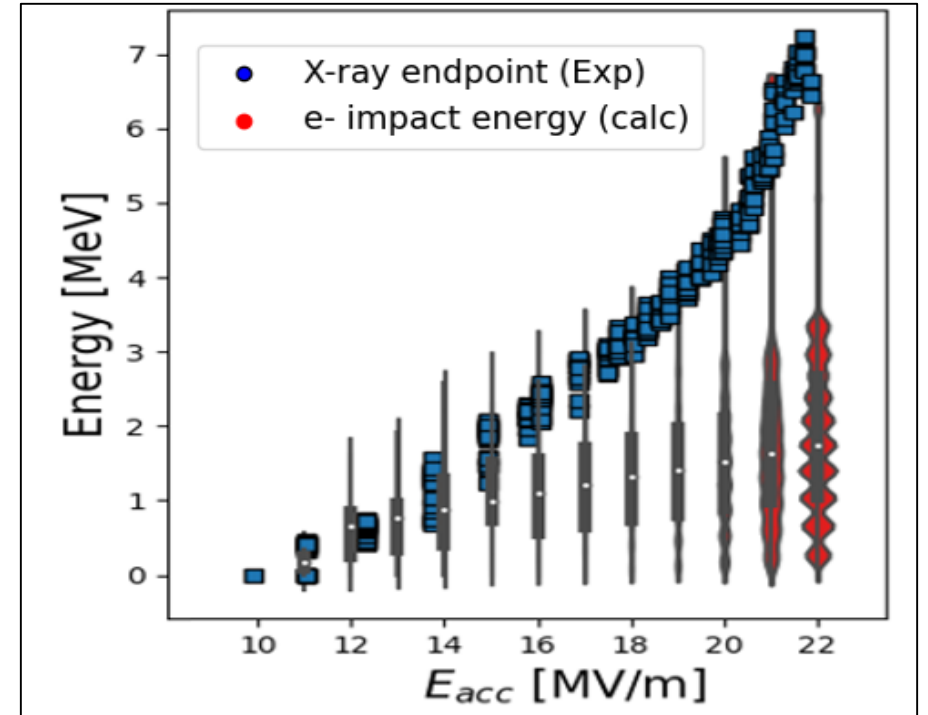
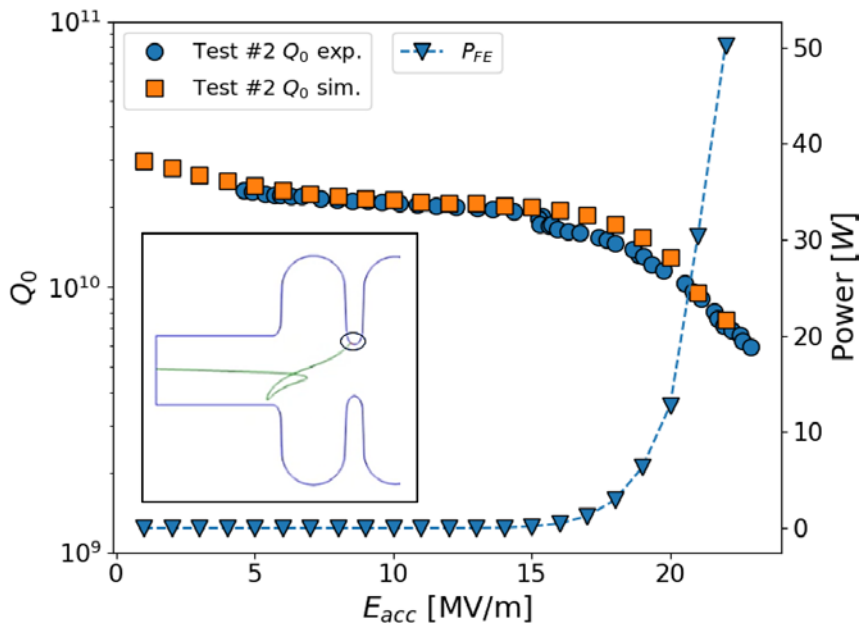

- β_{FE} is evaluated by Fowler-Nordheim fit
- FE-electron pattern is generated for every E_{acc} value, with a *Fishpact*-based code, by probing different emission sites
- Simulated e^- impact energies are matched with X-ray spectrum measured by scintillator
- Overall power P_{FE} is evaluated for the best match, and the Q-curve calculated
- **The resulting site is nearby iris 2, with $\beta_{FE} = 300$ and $S = 1 \times 10^{-15} m^2$**

B61-EZ-002 quench diagnostics

pi-mode: quench at 23 MV/m

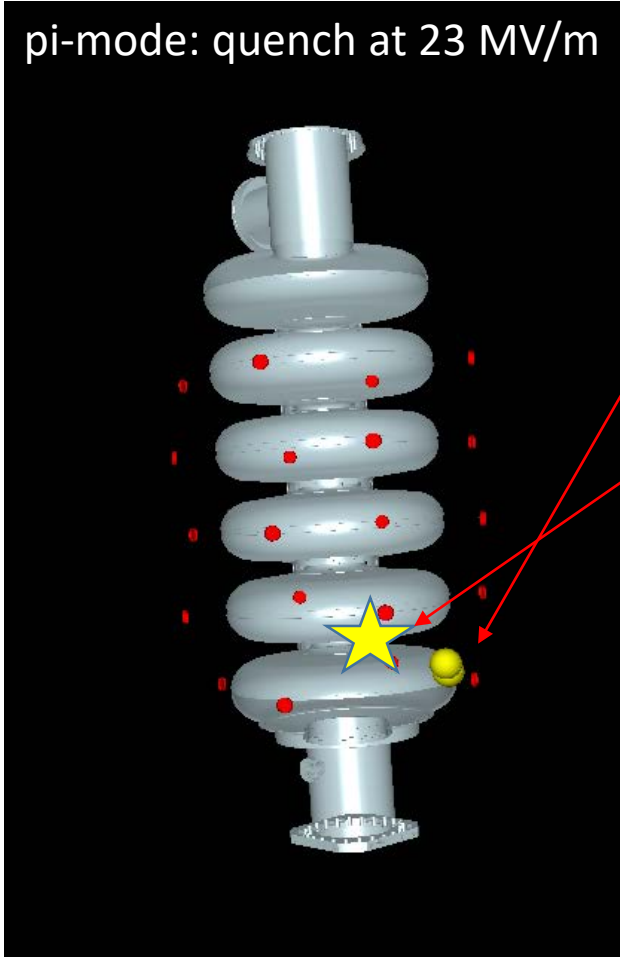

QuenchPosition All Sensors [x,y,z]				QuenchPosition [r,theta,z]			
0	-195.19	-48.66	-318.93	0	201.162	-166.002	-318.932
0				0			
QuenchPosition Moved Sensors [x,y,z]				QuenchPosition2 [r,theta,z]			
0	-198.40	-49.16	-332.28	0	204.398	-166.082	-332.281
0				0			

Possible FE site

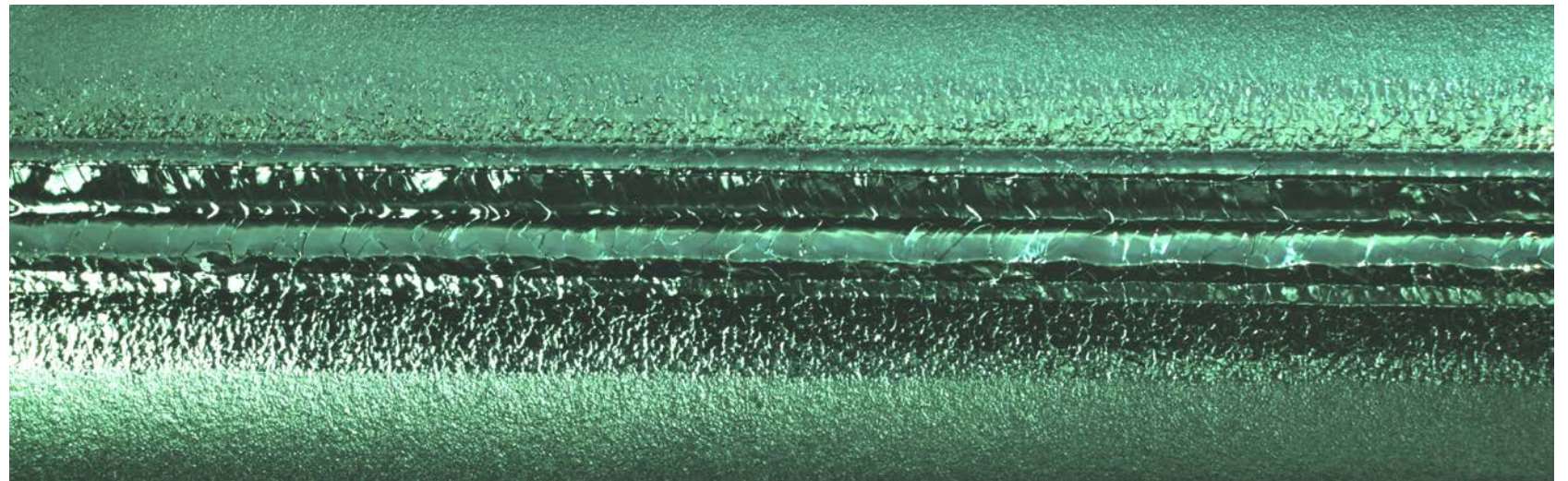

Second sound:

Quench position located in Cell 1 equator at angle 194°

No significant features can be noticed by visual inspection

Quench induced by FE?

$$\text{Radiation Yield } Y(E) = \frac{3 \times 10^{-4} Z(\gamma - 1)}{1 + 3 \times 10^{-4} Z(\gamma - 1)}$$

for $E_e = 1 \text{ MeV}$ $Y = 1\%$

99% of power (50W) goes into heat

T-sensors during cooldown

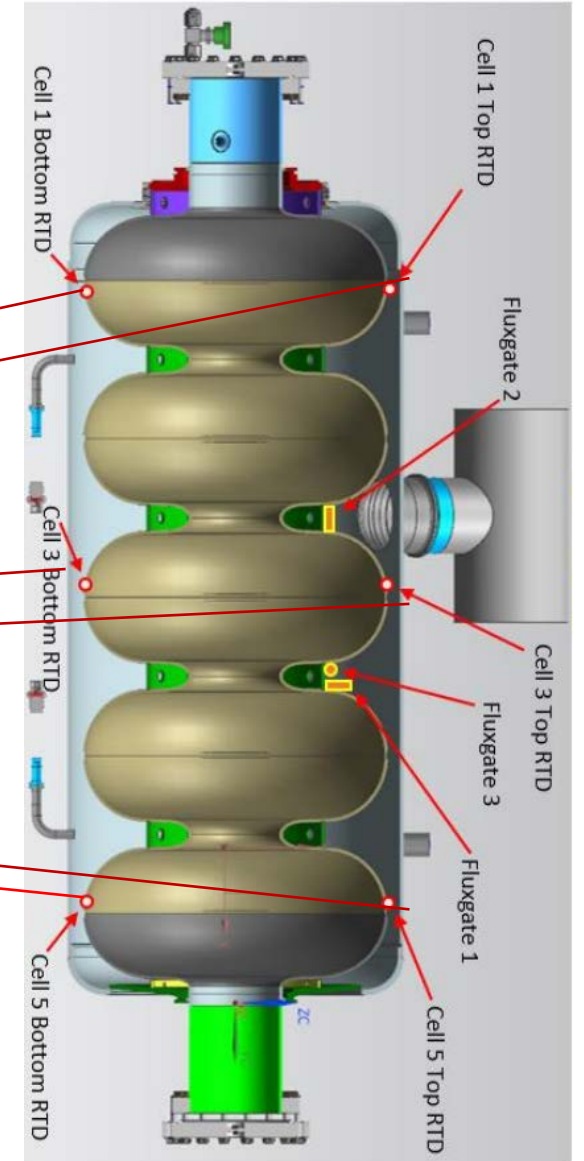
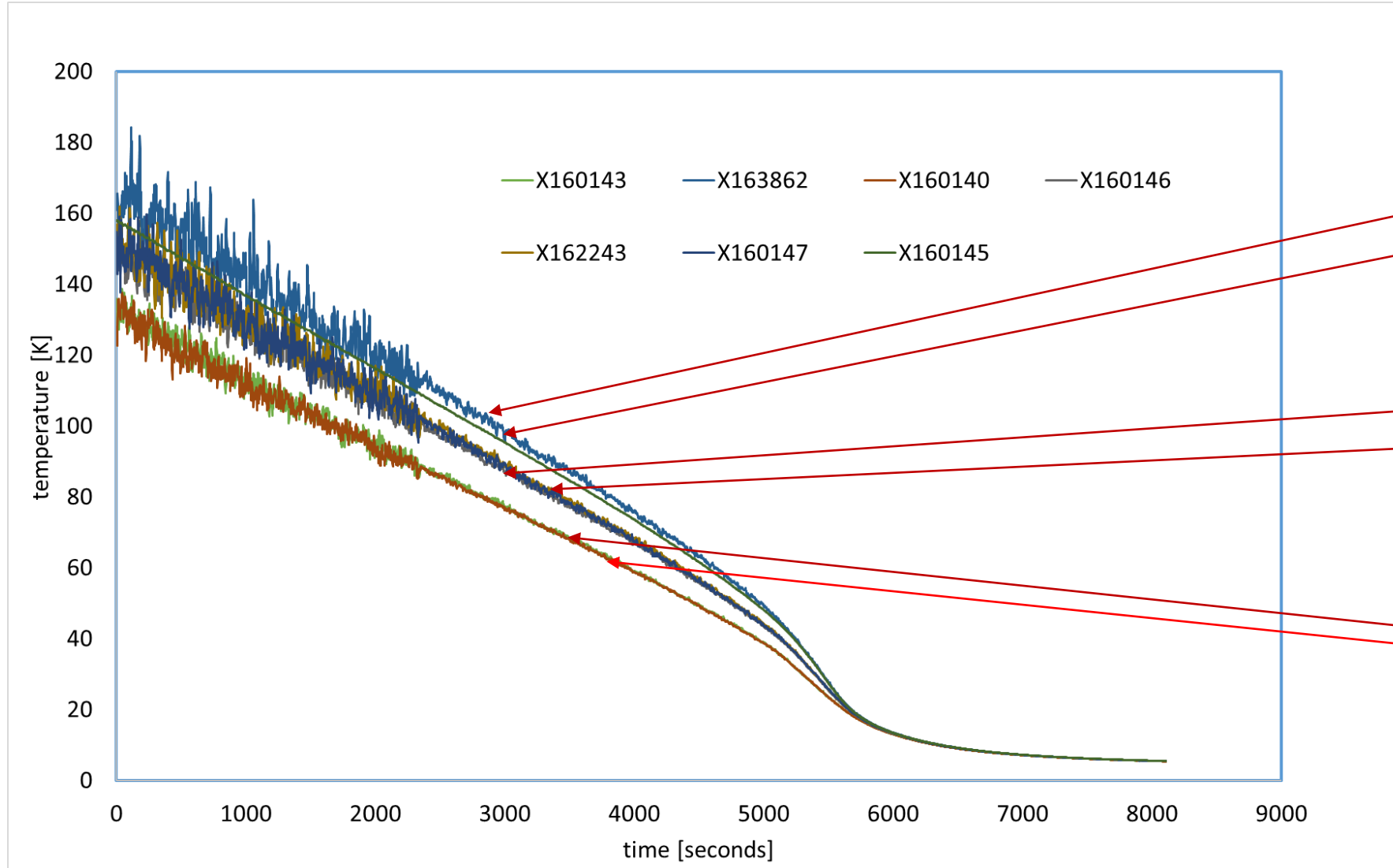

T-sensors and Fluxgate reading across T_c

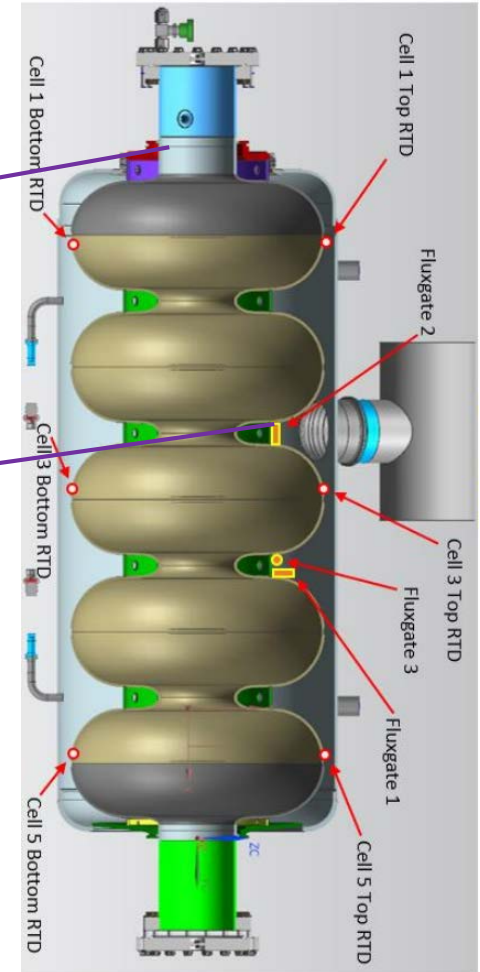
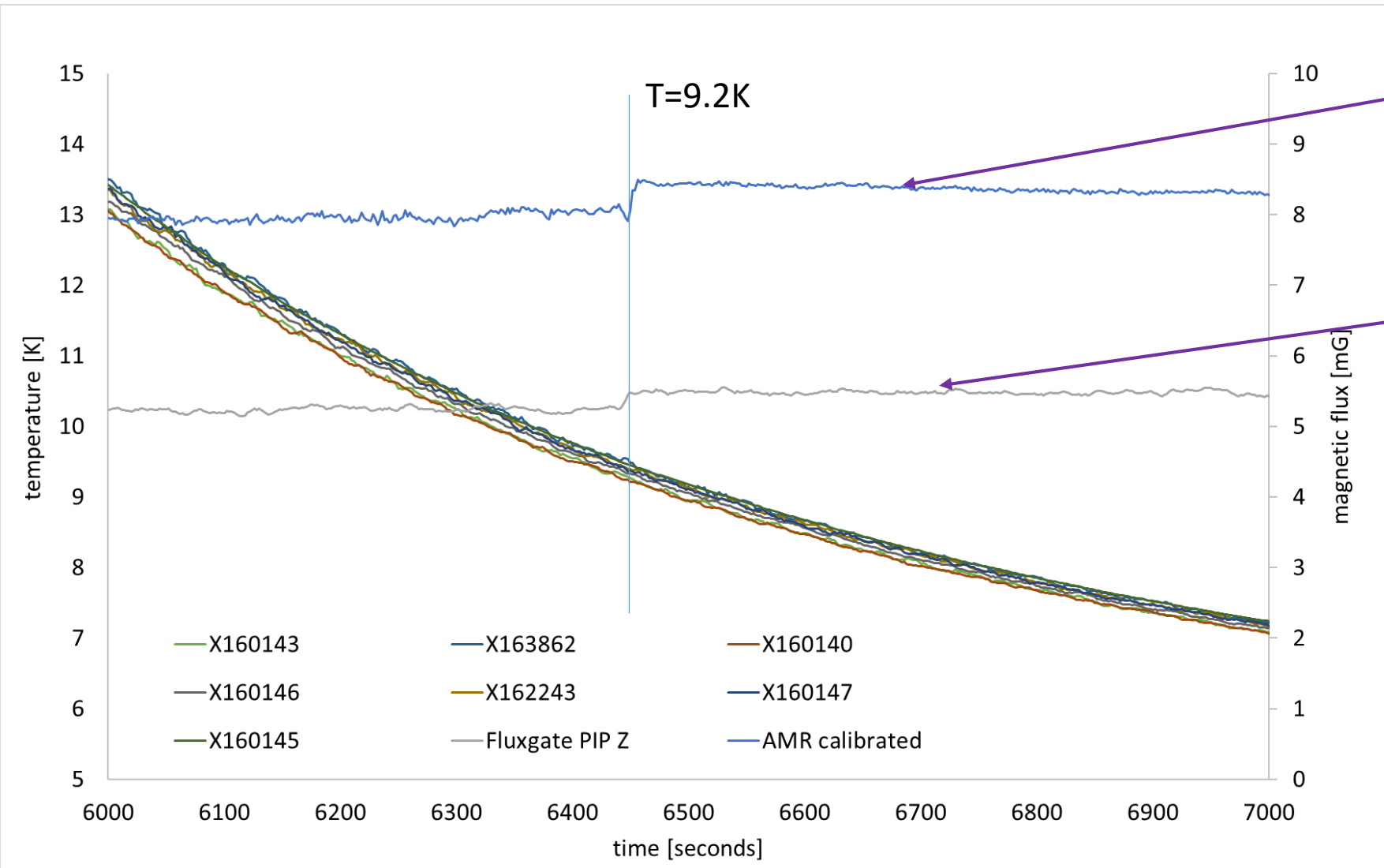

$$\nabla T \approx 0.2 K/m$$

Trapped flux efficiency=92%

LHe transferred from cavity top

conclusions

- PIP-II project initiated the season for high-Q/high-G measurements @ INFN-LASA lab.
- The Cryostat test facility is being updated with improved cooldown rates and diagnostics.
- Extensive experience has been gained from tests on the PIP-II cavity prototype.
- INFN-LASA is ready to tackle the challenges of future high-Q/high-G projects and collaborations.