

Yevgen Bilevych, Klaus Desch,  
Sander van Doesburg, Harry van  
der Graaf, Fred Hartjes, Jochen  
Kaminski, Peter Kluit, Naomi van  
der Kolk,  
Cornelis Ligtenberg,  
Gerhard Raven, and  
Jan Timmermans

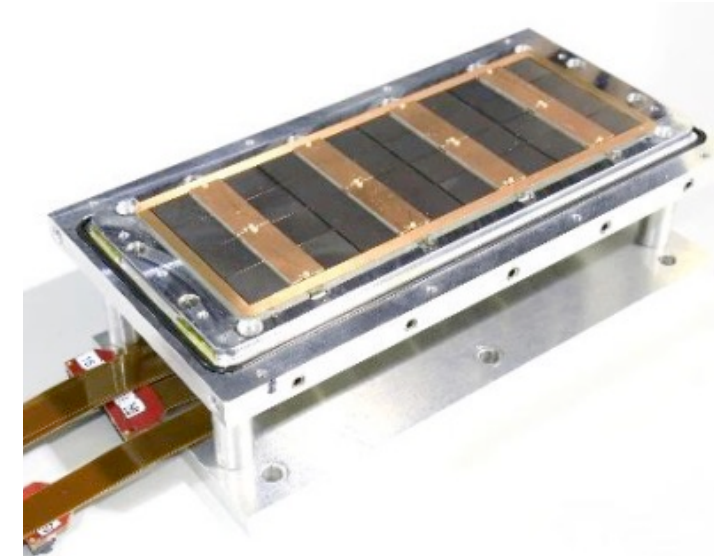

LCTPC DESY March 2024

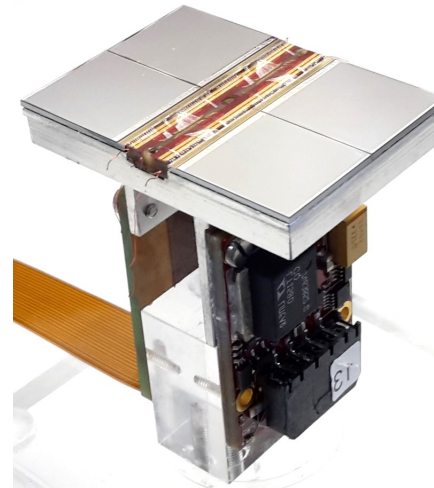

LCTPC DESY meeting March 2024



## Performance of dEdx

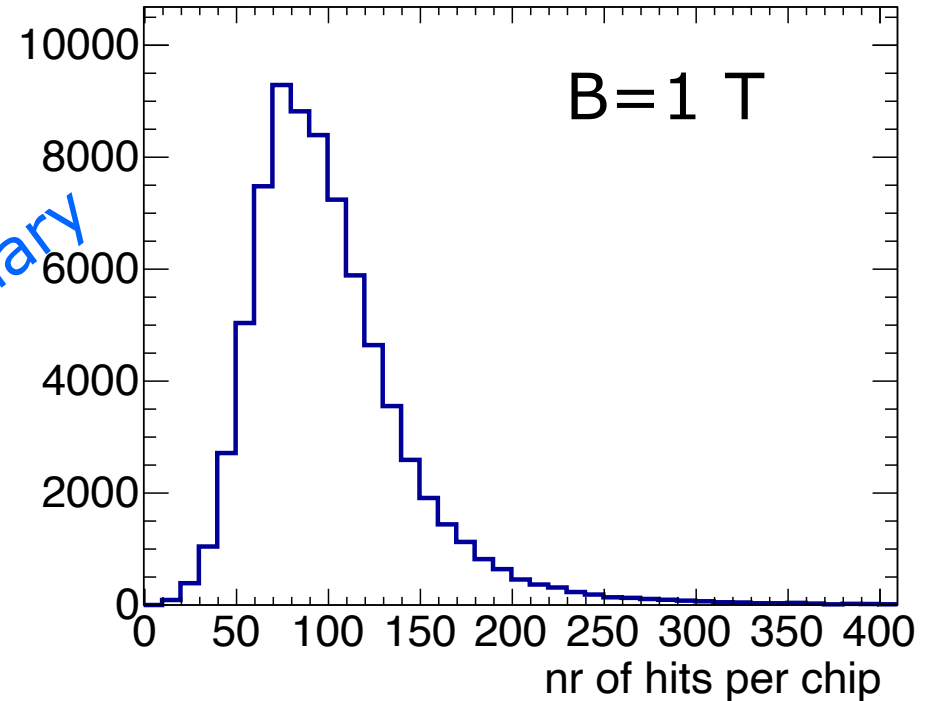
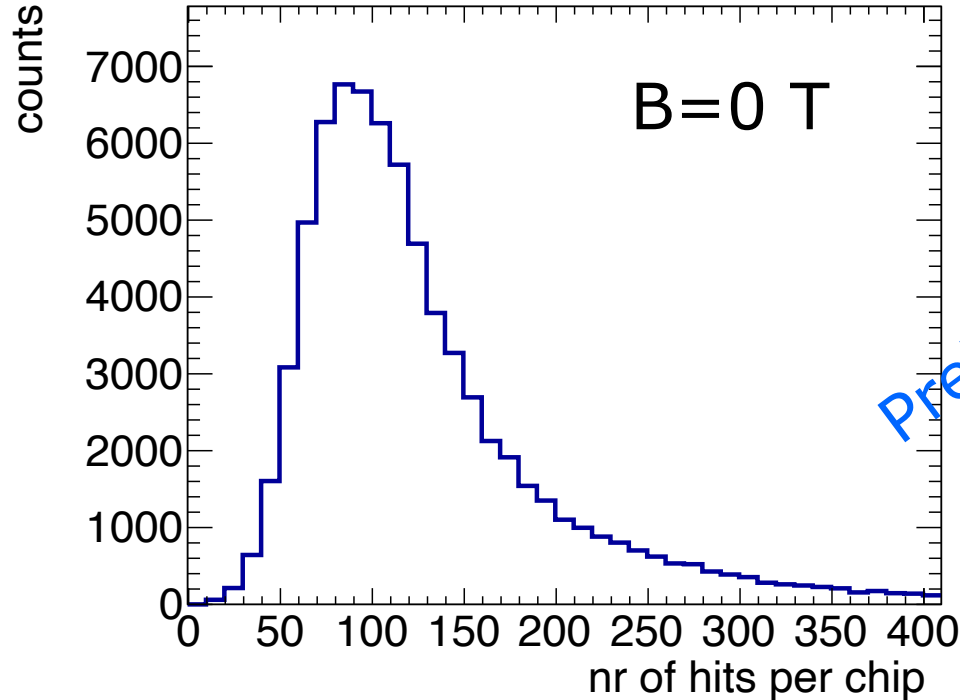

Preliminary

- B=0 T has a large Landau tail
- B=1 T smaller Landau tail and a more gaussian distribution
- An electron crossing 8 chips in the module has about 1000 TX3 hits

## Hits per chip scan vs grid voltage

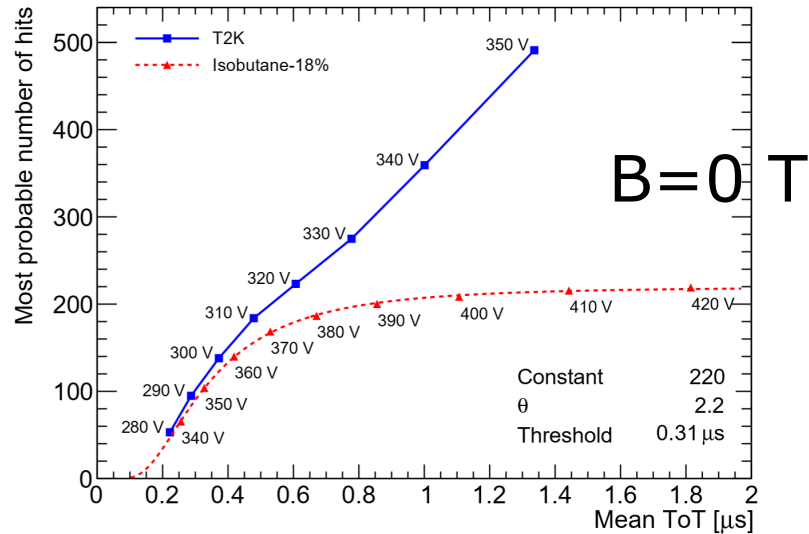

Figure 4.7: Number of hits per cluster from an  $^{55}\text{Fe}$  source for a T2K gas mixture (blue squares) and an isobutane/argon (18/82) gas mixture (red triangles). The values next to the data points indicate the negative grid potential ( $-V_{\text{grid}}$ ). The points of the isobutane-18 are fitted with Equation (4.2) shown with a red dashed line, and the points for the T2K gas mixture are connected with blue straight line segments. The Timepix3's threshold was set to 515 e.

## Current understanding

- B=0 T has a large Landau tail due to UV photons that are produced
- The HV scan shows the extra hits that are produced
- B=1 T has a reduced Landau tail due to the B field (electrons curl up)

This has large impact on the performance of dEdx: the smaller the fluctuations the better!

## Analysis of dEdx performance

- Combine chips to form 1 m long track with 60 % coverage for electrons
- Method 1) reject large clusters and then runs dEdx @ 90% (gives nr of selected hits)
- Method 2) fit the slope of the scaled minimum distance (d) distribution with an exponential function (after scaling down the N(d) distribution):  

$$N(d) \text{ scaled} = N \text{ scale} (d) N \text{ observed} (d)$$

$$N(d) \text{ scaled} \text{ is then fitted fr each track with } N_0 \exp(-\text{slope } d)$$
- Calculate the "dEdx" variable (method 1 = nr of selected hits; method 2 = slope) for electrons and MIP (== 70% of hits)
- Resolution is  $\sigma (dEdx) / dEdx$  (for  $\sigma$  we use the rms)
- Scale corrected MIP resolution: scales up the resolution by  

$$\text{factor} = dEdx(\text{MIP})/dEdx(e)/0.7 = \text{method 1(2)} \ 1.10 \ (1.18)$$

### Single chip

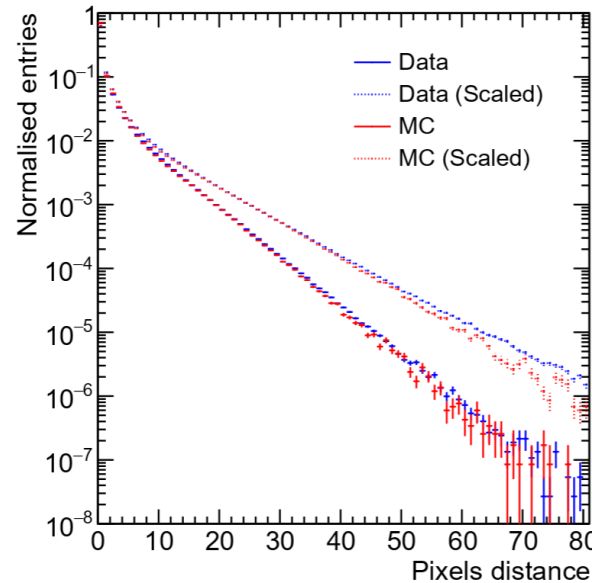

### Quad module

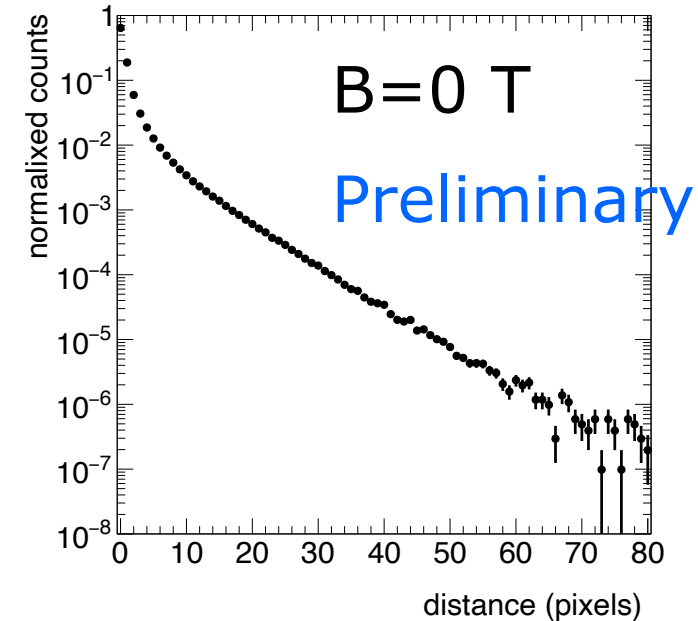

Calculate minimum distance between the hits.

The slope of the distribution is related to the number of primary clusters /cm

Figure 5.19: Distribution of distance between hits for a 2.5 GeV electron in pixels from test beam data (blue) and from a Monte Carlo simulation (red).

## Performance of dEdx

### Method 2: Fit slope of the distance distribution

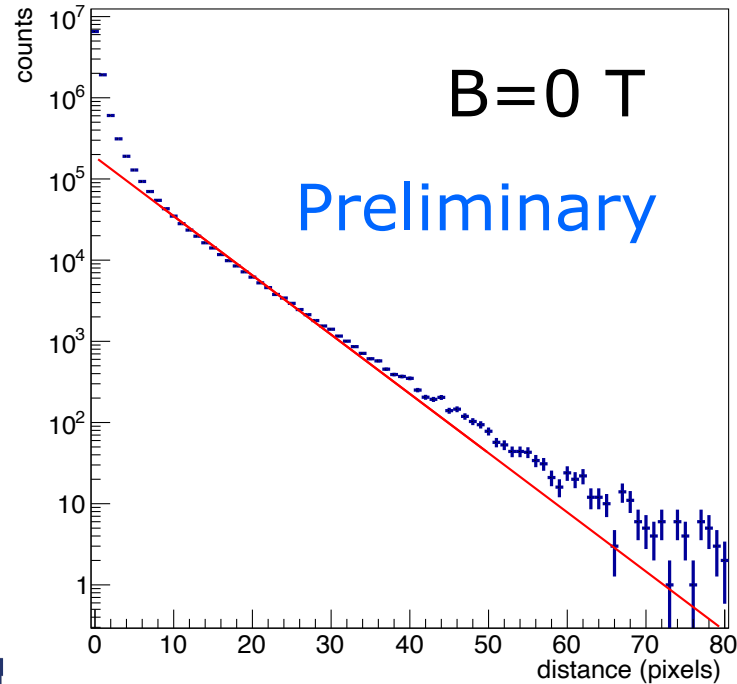

From 10 clusters onwards an exponential distribution is followed.

Below 10 the distribution will be down-weighted (by 1/weight). The weights are:

Weights B=0 = { 35.0467 , 12.1497 , 4.52914 , 2.76311 , 1.99386 , 1.59795 , 1.3656 , 1.21409 , 1.11898 , 1.04385 };

Weights B=1 = { 18.0291 , 5.92609 , 1.82486 , 1.26074 , 1.08588 , 1.014 , 0.986373 , 0.967029 , 0.959339 , 0.9649 };

Note the difference in weights in the B=0 and 1 T data sets. This is related to the fluctuations

## dEdx performance method 1

MIP scale corrected  
resolution  
5.3%  
[electron has 3.6%]

1 m track 60% and  
coverage

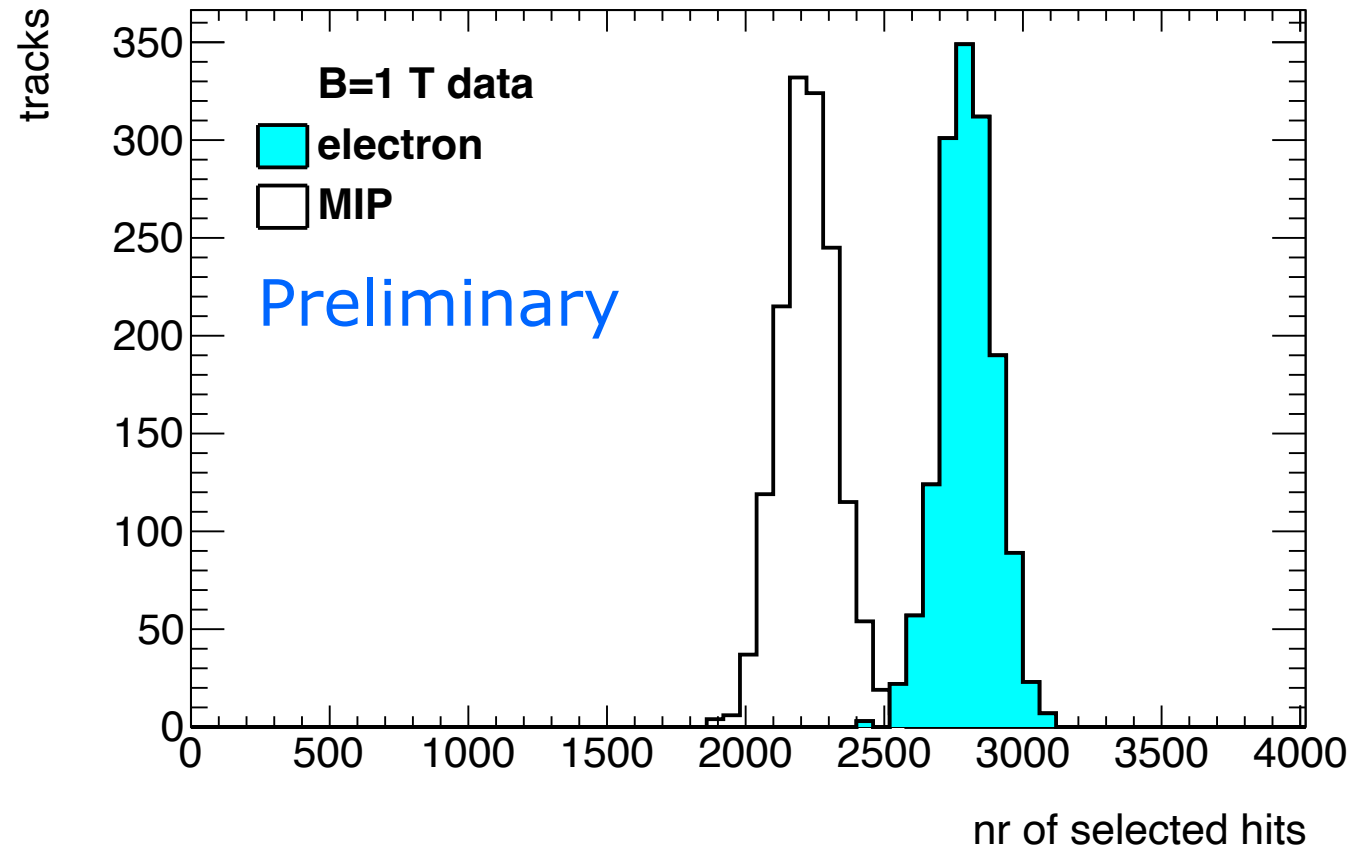

## dEdx performance method 2

MIP scale corrected  
resolution  
4.2%  
[electron has 2.9%]

1 m track 60% and  
coverage

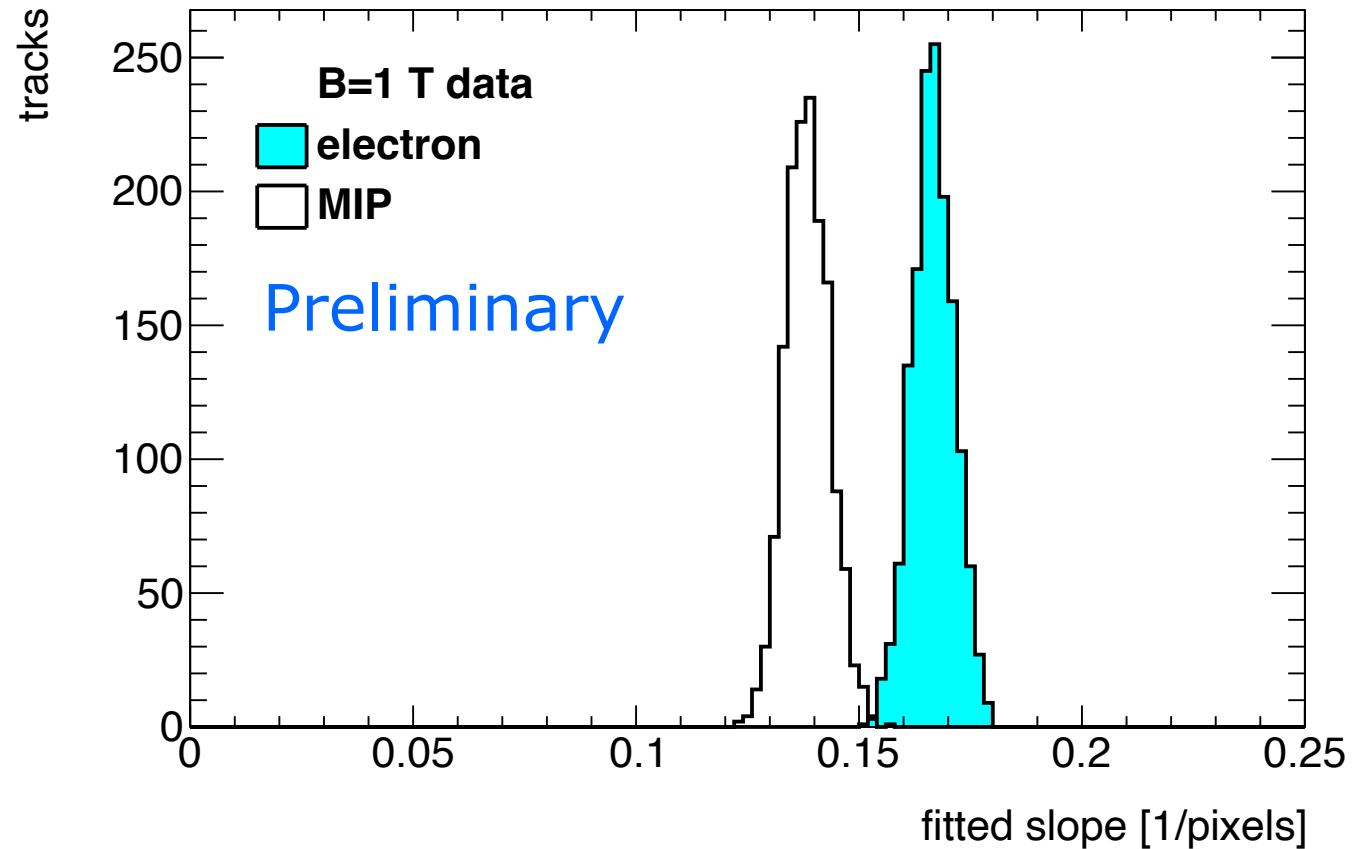



## Performance of dEdx

The dEdx resolution for MIPs (70% of the electron dE/dx) from data by combining tracks to form a 1 m long track with realistic coverage  $\sim 60\%$  coverage (corrected for the e-MIP scale).

Preliminary

Method	B=0 Resolution (%)	B= 1 T Resolution (%)
(1) dEdx 90 tail	7.7	5.3
(2) Fit slope	6.8	4.2

The “dEdx 90 tail” method is truncation at 90% where large clusters are identified and removed (tail reduced)  
 For the “Fit slope” method (2) an exponential distribution (with the slope and amplitude as free parameters) is fitted to the distance between the hits

## dEdx Performance extrapolated to ILD detector

Test beam B = 1 T  
p = 5,6 GeV/c

Method 2 fit slope of the  
distance distribution

MIP scale corrected  
resolution 4.2%

electron resolution 2.9%

1 m track 60% and  
coverage



## ILD detector

rInner = 329 rOuter = 1770 mm

MIP resolution = 3.6% at  $\theta = \pi/2$

electron resolution = 2.5%

Assume Pixel TPC performance at  
B = 1 T at p = 5,6 GeV/c



## ILD dEdx performance

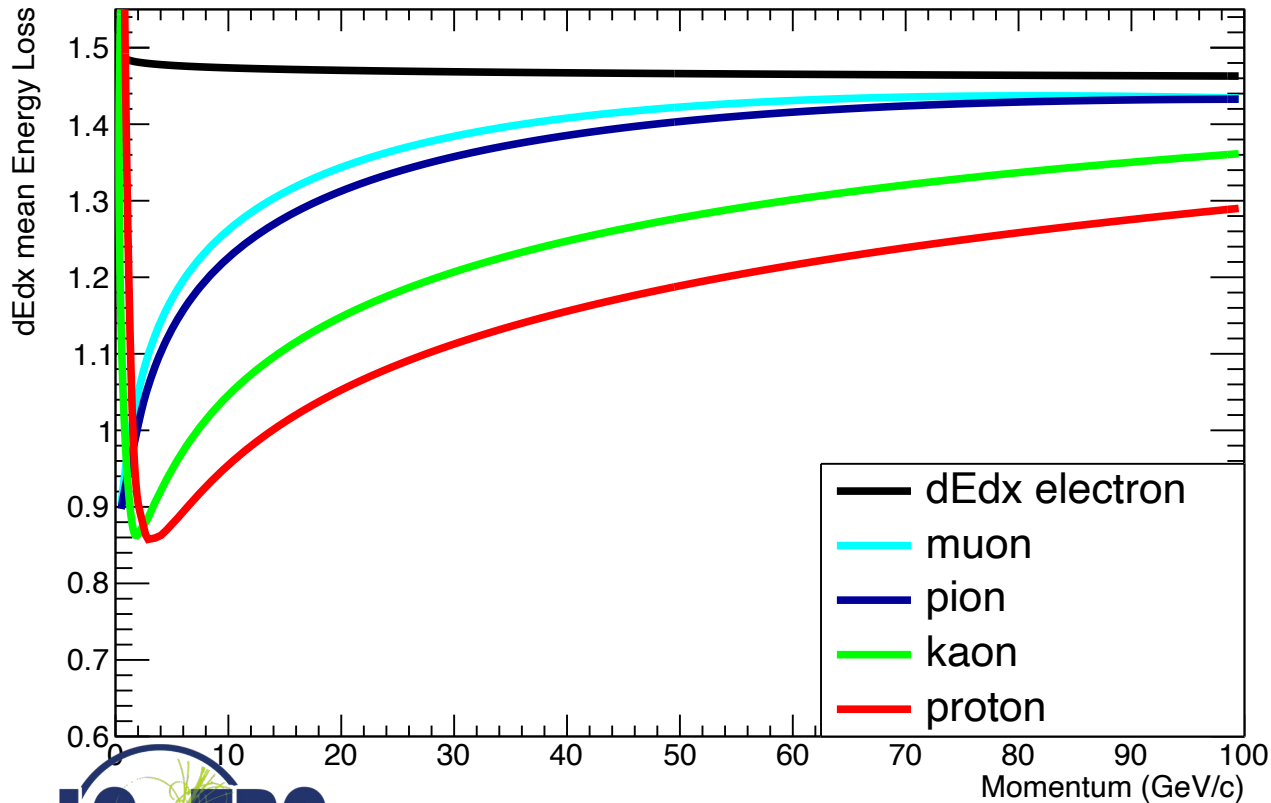

- Contacted Ullrich Einhaus for dEdx studies in ILD
- Extracted the ILC soft parametrisations for energy loss based on G4 and full simulation of the ILC TPC with T2K gas
- [Link](#) generated in 2020 with ILC soft v02-02 and v02-02-01

## dEdx performance

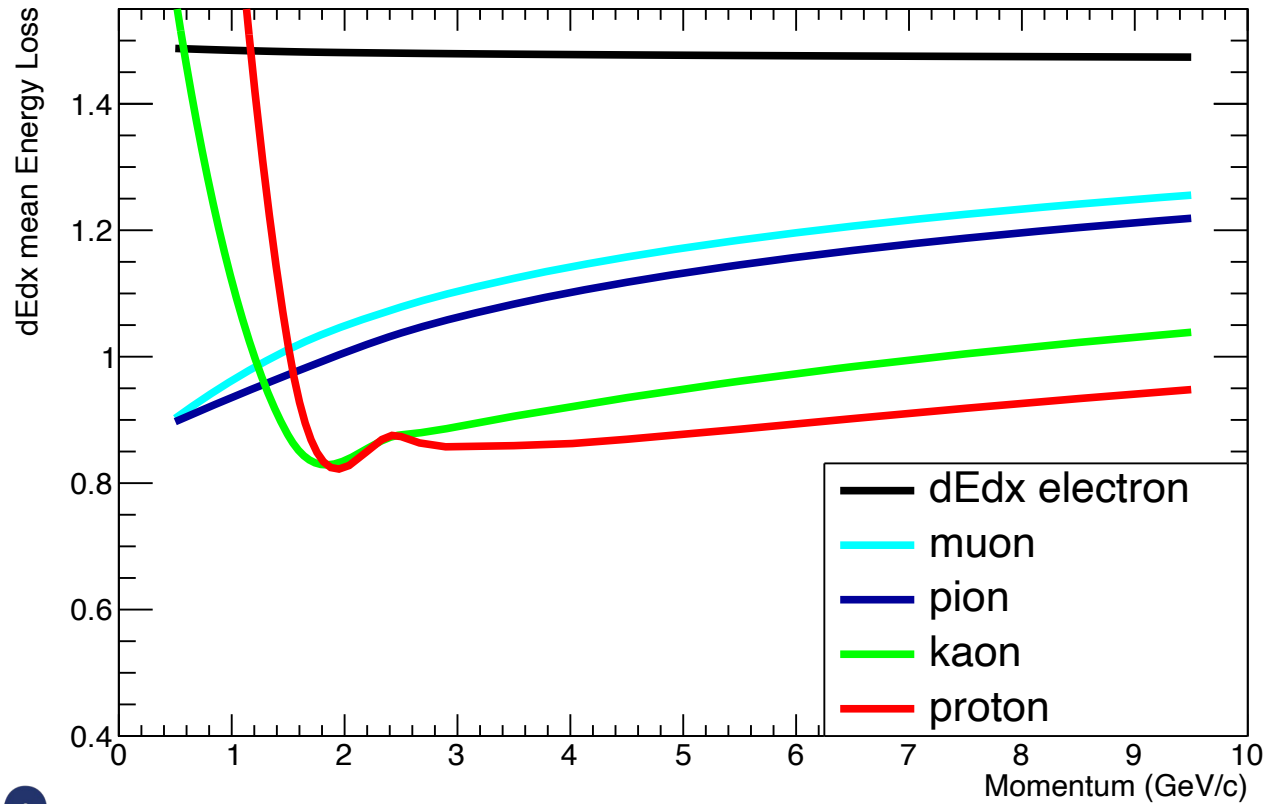

- zoom on Low momenta

## Pixel TPC dEdx performance

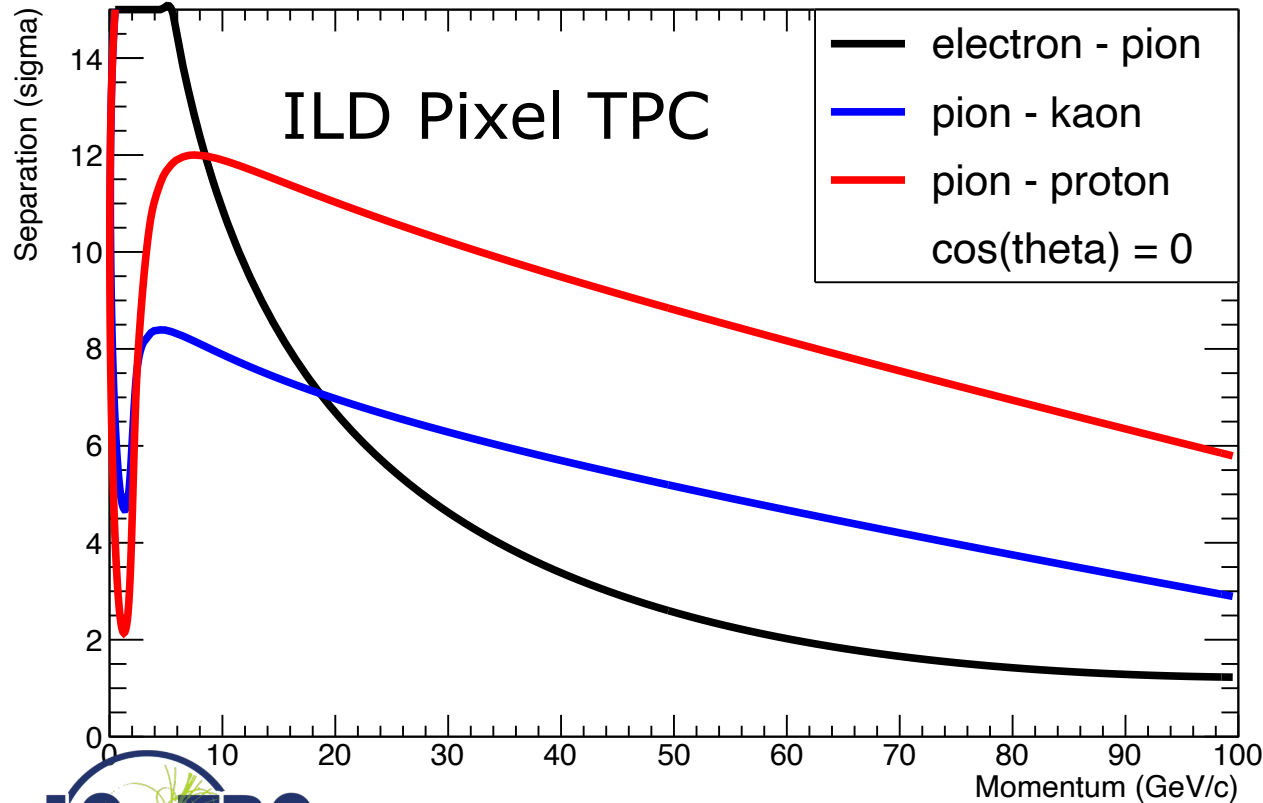

- ILD Performance with:
  - rInner = 329 mm
  - rOuter = 1770 mm
  - zMax = 2350 mm // half length
- Pixel TPC resolution from electron p = 5 (6) GeV test beam (for B = 1 T) of 2.5% at cos θ = 0
- Resolution scales as:
 
$$1/\sqrt{\text{track length} \cdot \langle E_{\text{loss}} \rangle}$$
- Separation electron pion
 
$$|\langle E_{\text{loss}} e \rangle - \langle E_{\text{loss}} \pi \rangle| / \sigma_{\pi}$$
- Separation pion kaon
 
$$|\langle E_{\text{loss}} \pi \rangle - \langle E_{\text{loss}} K \rangle| / \sigma_{\pi}$$

## Pixel TPC dEdx performance

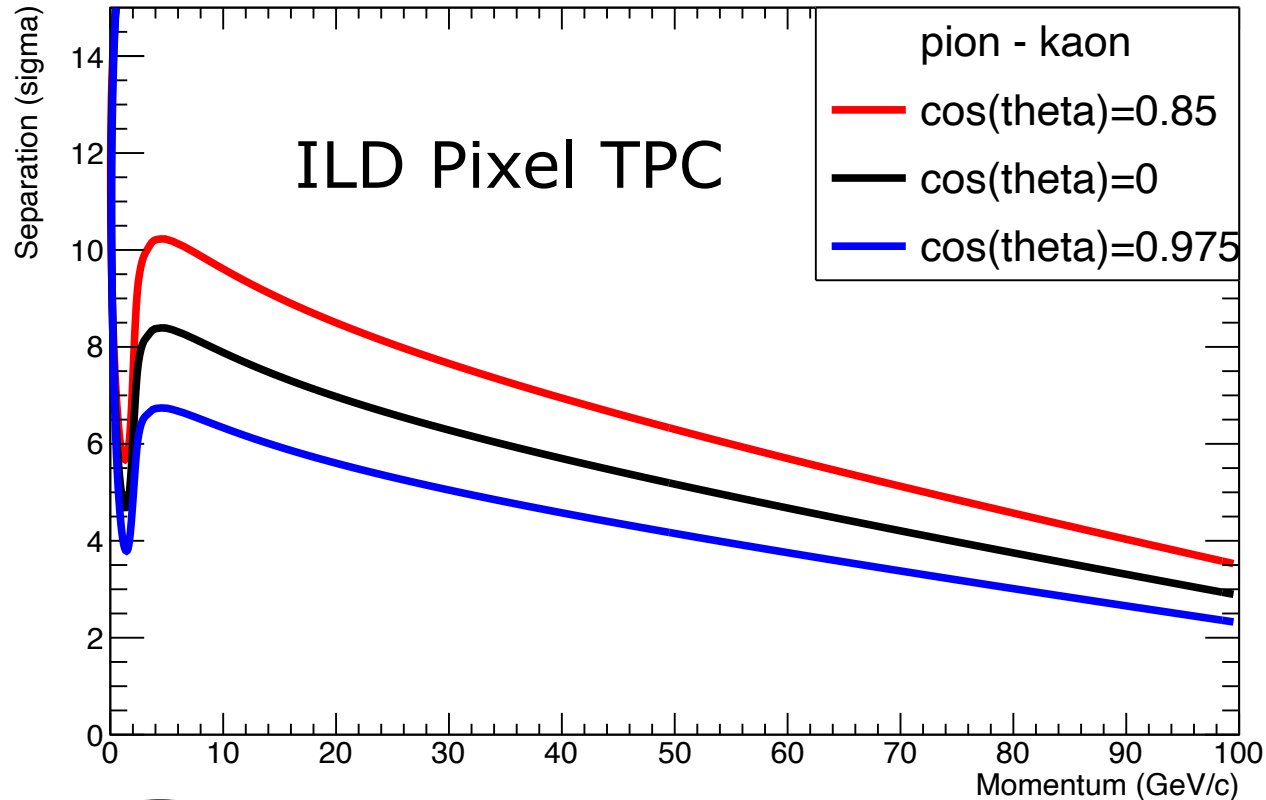

- Separation pion kaon  
 $|\langle E_{\text{loss}} \pi \rangle - \langle E_{\text{loss}} K \rangle| / \sigma_{\pi}$
- Separation pion kaon for different cos(theta) values due to the track length dependence
- For cos(theta)=0 till 0.95 the separation lies between the black and red curves. Only above 0.95-0.975 the separation drops till the blue curve.
- Excellent performance over very large polar angle range

# Simulation of ILD TPC with pixel readout

- To study the performance of a large pixelized TPC, the pixel readout was implemented in the full ILD DD4HEP (Geant4) simulation
- Changed the existing TPC pad readout to a pixel readout
- Adapted Kalman filter track reconstruction to pixels

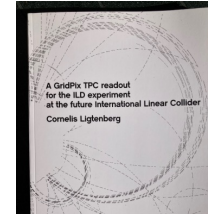

details: PhD [thesis](#)  
Kees Ligtenberg

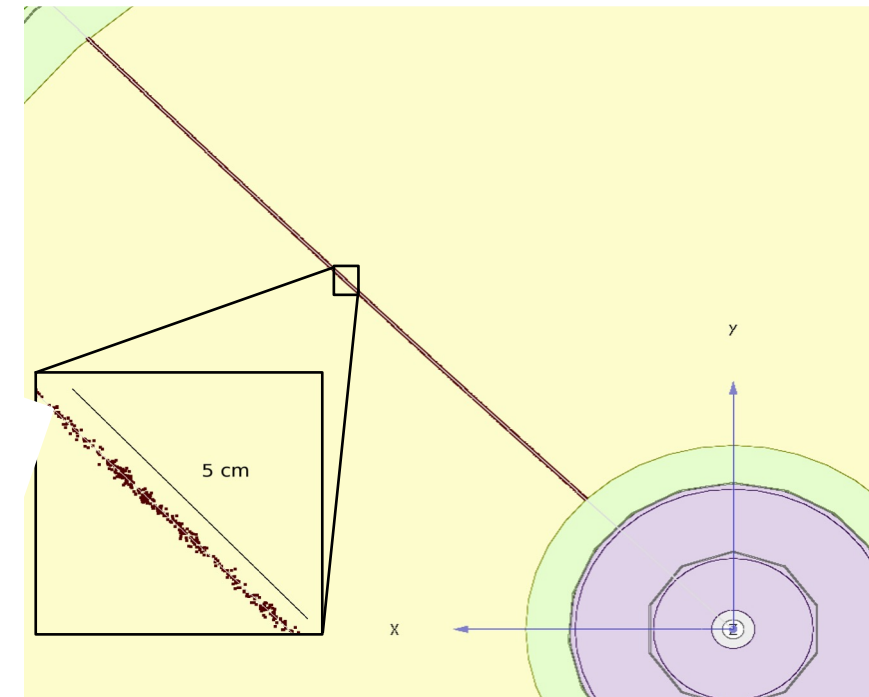
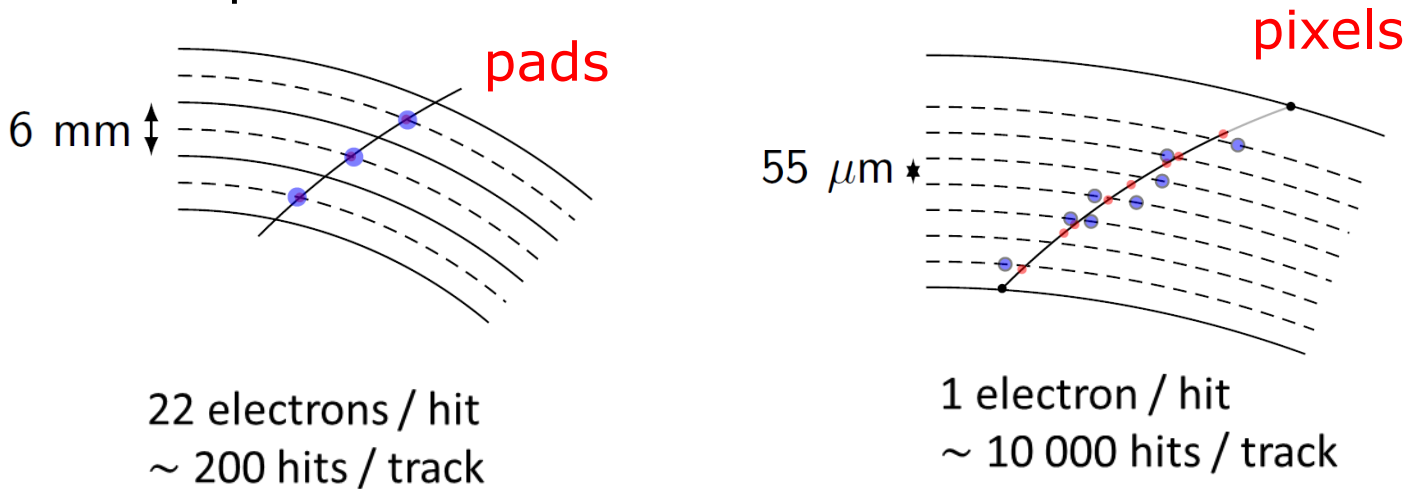

50 GeV muon track with  
pixel readout

# Performance of a GridPix TPC at ILC

- From full simulation the momentum resolution can be determined
- Momentum resolution is about 15% better for the pixels with realistic coverage (with the quads arranged in modules coverage 59%) and deltas.

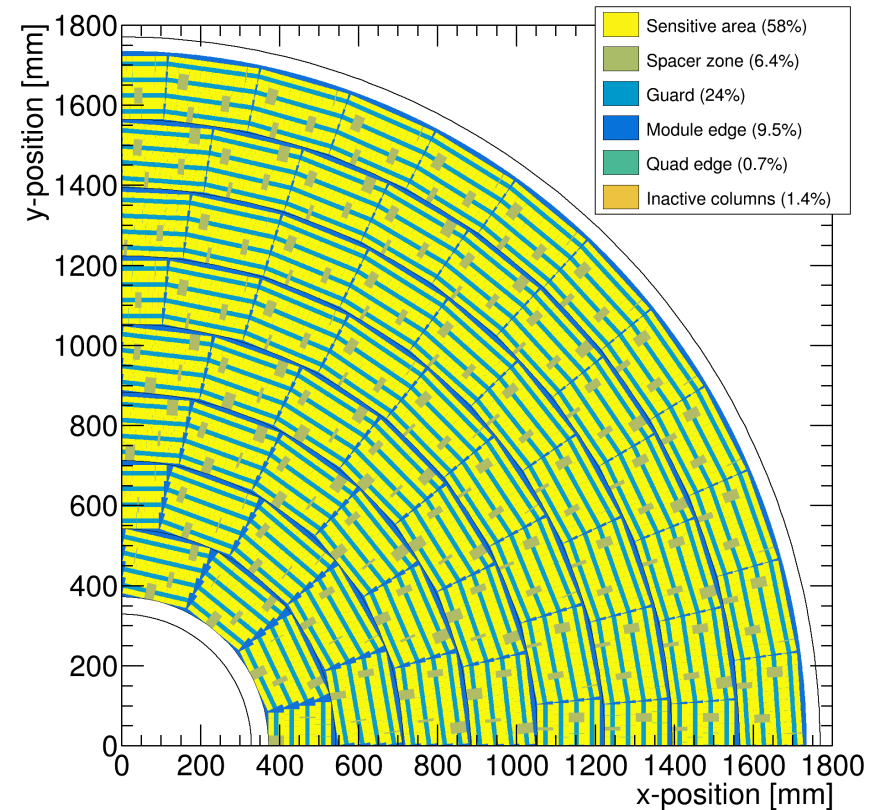
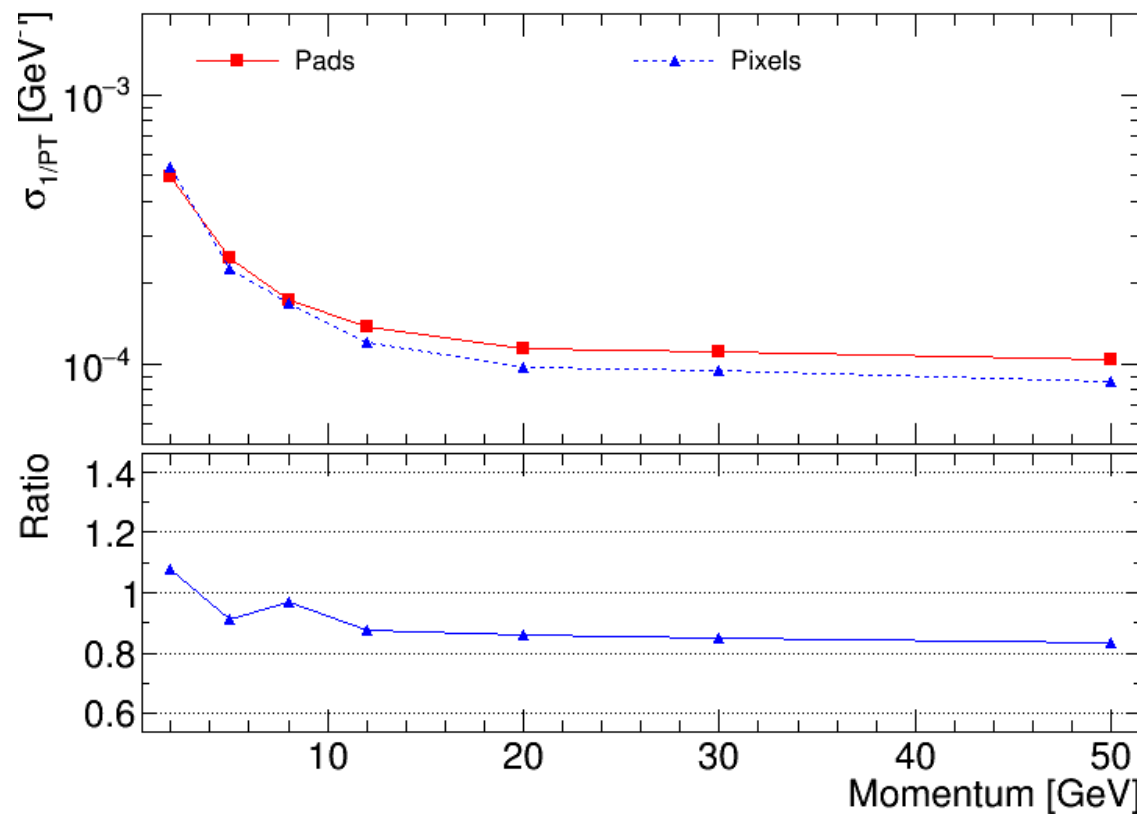



# Performance of a GridPix TPC

## Further integration of the Pixel TPC in the ILD software

A thought by Frank Gaede about combining pixels into pads:

- one could easily project the pixels into pads - of similar/same size as in the current ILD simulation
- but rather than simply adding up the charge, you can compute the true center-of-gravity based position and charge of the virtual pad
- in a second step you combine neighbouring pads to a cluster and compute the position (in  $r$ - $\phi$ ,  $z$ ) of the cluster and create a SimHit from this
- both operations should be linear in time (i.e. one loop over pixels/pads)

This procedure should preserve all the point resolution information of the pixels but allow you to run standard Clupatra as for the pad based TPC reconstruction

# Pixel TPC: Track fitting at the edge

- In case of the a realistic geometry with detector edges, Kees Ligtenberg observed a worsened momentum resolution and momentum biases. This was traced down to be caused by biases in the residuals at the edge of the detector
- The conclusion was that the track fit should be updated to take into account the (small) biases in the residuals at the detector edge(s)
- Recently, a master student (computational physics) at the UvA, Peter Voerman, has written a track fit that corrects the biases in one pass: "Track fitting at the edge".
- The technique can also be applied to fit hits from other gaseous or non-gaseous detectors:
  - a centre of gravity technique is used (with measured charges over multiple strips near the edge)
  - in case of silicon detector hits near the boundaries of the sensitive volume

# Pixel TPC: Track fitting at the edge



## Correcting bias on the detector edge

Peter Voerman

- ▶ Close to the edge of a detector, measurements of the particle's position are biased, leading to biased track parameters during track fitting
- ▶ The bias in the measurements can be described by this equation:

$$c = \begin{cases} 0 & \text{if } x < p_1 \\ \frac{(x-p_1)^2}{p_0} & \text{if } p_1 < x < p_2 \\ \frac{2(p_2-p_1)(x-p_2)}{p_0} + \frac{(p_2-p_1)^2}{p_0} & \text{if } p_2 < x \end{cases} \quad (1)$$

- ▶  $p_0$ ,  $p_1$  and  $p_2$  are dependent on the amount of diffusion in the detector and the detector geometry

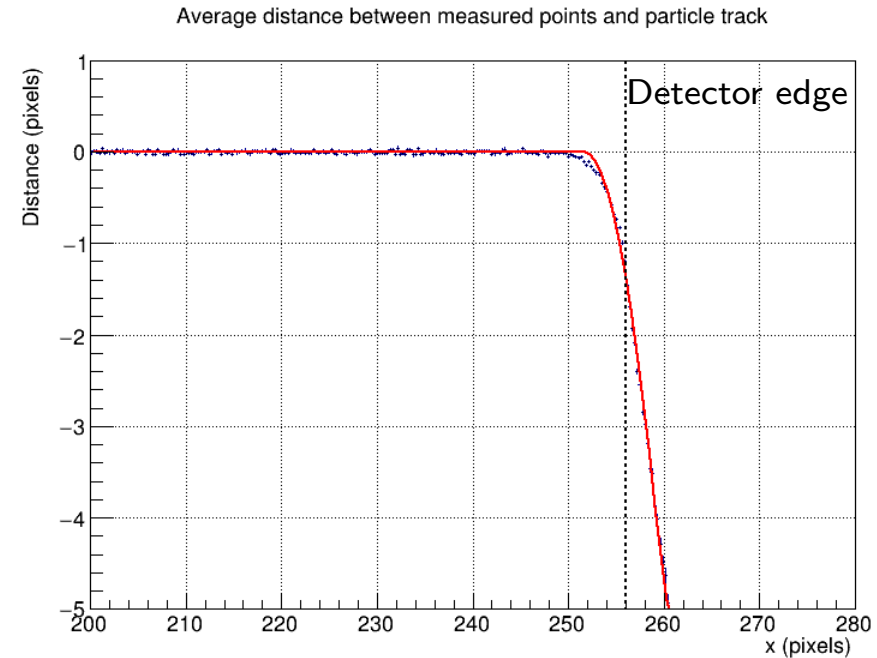

# Pixel TPC: Track fitting at the edge



## Correcting bias on the detector edge

Peter Voerman

- ▶ The fit is done by minimizing the following  $\chi^2$ :

$$\chi^2 = \sum_{i=1}^N \frac{(\sin(\phi)(x_{m,i} - c_i) - \cos(\phi)y_{m,i} - d_0)^2}{\sigma_i^2} \quad (2)$$

- ▶ Without correction,  $c_i = 0$
- ▶ With correction,  $c_i$  is calculated using equation 1
- ▶ As seen in the figures, this correction significantly reduces the bias in the fitted parameters as the fraction of measurements close to the edge increases

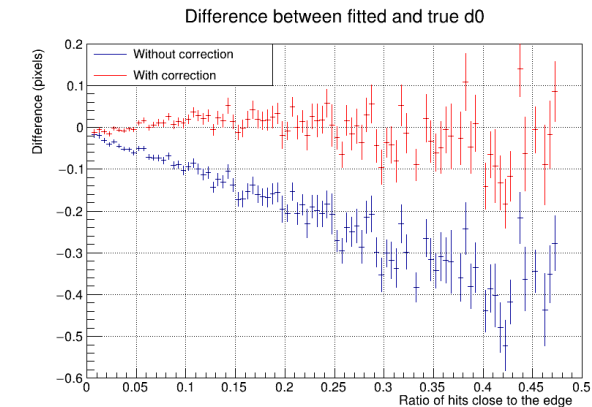
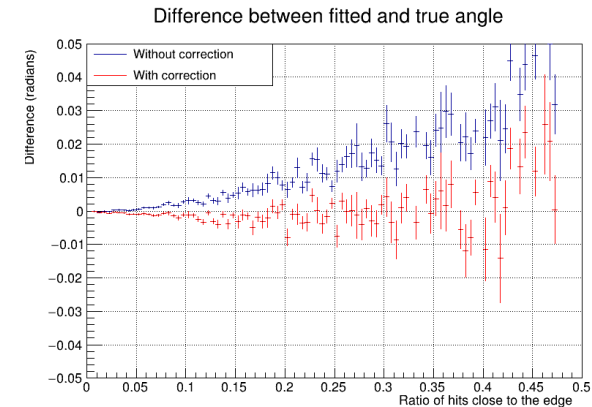

2/2

- dE/dx resolution for an electron with  $p=5,6$  GeV/c of 1 m track length with 60% coverage is measured to be 3.5% (at  $B = 1$  Tesla)
- The extrapolated resolution for the ILD detector is 2.5%
- This allows for particle identification and separation of Kaons from pions up to momenta of 45 GeV with more than  $5\sigma$  for  $\cos(\theta)$  from 0 to 0.95.
- A test beam @ FermiLab with a quad in a TPC is planned (2024, US Grant EIC)
  - an EIC R&D program for CO2 cooling is funded (2023) (Yale, Stony Brook, Purdue, Bonn, Nikhef)
  - Focus is particle identification and tracking at the Electron-Ion-Collider
- A pixel TPC has become a realistic viable option for experiments
  - High precision tracking like ILD@ILC in the transverse and longitudinal planes, dE/dx by electron and cluster counting, excellent two track resolution, digital readout that can deal with high rates

# Operation of a Pixel TPC at CEPC or FCC-ee

# A Pixel TPC at CEPC or FCC-ee

The most difficult situation for a TPC is running at the Z.

At the Z pole with  $L = 200 \cdot 10^{34} \text{ cm}^{-2} \text{ s}^{-1}$  Z bosons will be produced at  $\sim 60 \text{ kHz}$

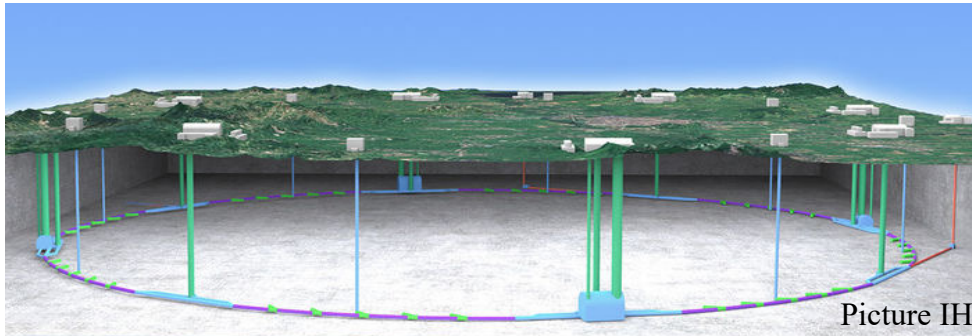

Picture IHEP

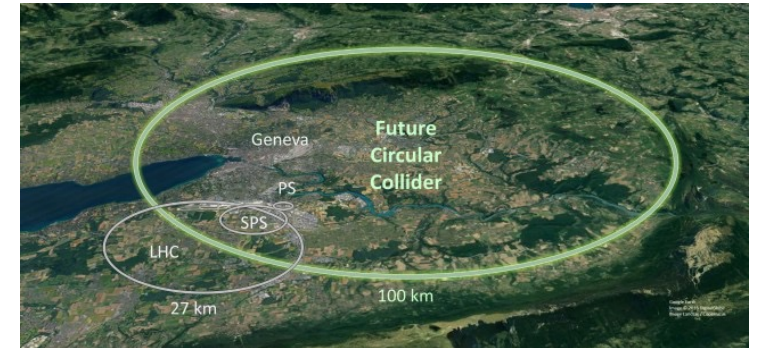

## ■ Can a pixel TPC reconstruct the events?

- The TPC total drift time is about  $30 \mu\text{s}$
- This means that there is on average 2 event / TPC readout cycle
- YES: The excellent time resolution: time stamping of tracks  $< 1.2 \text{ ns}$  allows to resolve and reconstruct the events

## ■ Can the current readout deal with the rate?

- Link speed of Timepix3 (in Quad) is 80 Mbps: 2.6 MHits/s per  $1.41 \times 1.41 \text{ cm}^2$
- YES: This is largely sufficient to deal with high luminosity Z running
- NB: Data size is not a show stopper as e.g. LHCb experiment shows using the VeloPix chip

# A Pixel TPC at CEPC or FCC-ee

## ■ What is the current power consumption?

- No power pulsing possible at these colliders (at ILC power pulsing was possible)
- Current power consumption TPX3 chip  $\sim 2\text{W}/\text{chip}$  per  $1.41 \times 1.41 \text{ cm}^2$
- So: good cooling is important but in my opinion no show stopper
- For Silicon detectors lower consumption for the chips and cooling is an important point that needs R&D (e.g. microchannel cooling).
- To save power the TPX3/4 chips can be run in LowPowerMode: **reduction factor 10.**

## ■ Can one limit the track distortions?

- There are two important sources of track distortions:
  - the distortions of the TPC drift field due to the primary ions
  - the distortions of the TPC drift field due to the ion back flow (IBF)
- At the ILC gating is possible; for CEPC or FCC-ee this is more involved, for a Pixel TPC a double grid is the best solution (see next slide)



# A Pixel TPC at CEPC or FCC-ee

- **Is it possible to reduce the IBF for a pixel TPC?**
  - IDEA: by making chip with a double grid structure (see next slide)
  - This idea was already realized as a TWINGRID NIMA 610 (2009) 644-648
  - For GEMs for the ALICE TPC this was also the way – several GEMs on top of each other to reduce IBF
  - For the Pixel the IBF can be easily modelled and with a hole size of 25  $\mu\text{m}$  an IBF of  $3 \cdot 10^{-4}$  can be achieved and the value for  $\text{IBF} \cdot \text{Gain} (2000)$  would be 0.6.
  - YES: the IBF can be reduced to 0.6 but this needs R&D
  - In the new detector lab in Bonn it is possible to make and study this device
- **What would be the size of the TPC distortions?**
  - Tera-Z studies by Daniel Jeans and Keisuke Fuji show that for FCC-ee or CEPC this means: distortions from Z decays up to  $< O(100) \mu\text{m}$
  - Beam strahlung gives (now) a factor 200 more background. Detector optimization and shielding is important for TPC and Silicon detectors to reduce pair background.
  - It was argued that in an ILD like detector the distortions can be mapped out using the VTX-SIT/SET detectors.

# Reducing the Ion back flow in a Pixel TPC

The Ion back flow can be reduced by adding a second grid to the device. It is important that the holes of the grids are aligned. The Ion back flow is a function of the geometry and electric fields. Detailed simulations – validated by data – have been presented in [LCTPC WP #326](#).

With a hole size of 25  $\mu\text{m}$  an IBF of  $3 \cdot 10^{-4}$  can be achieved and the value for IBF\*Gain (2000) would be 0.6.

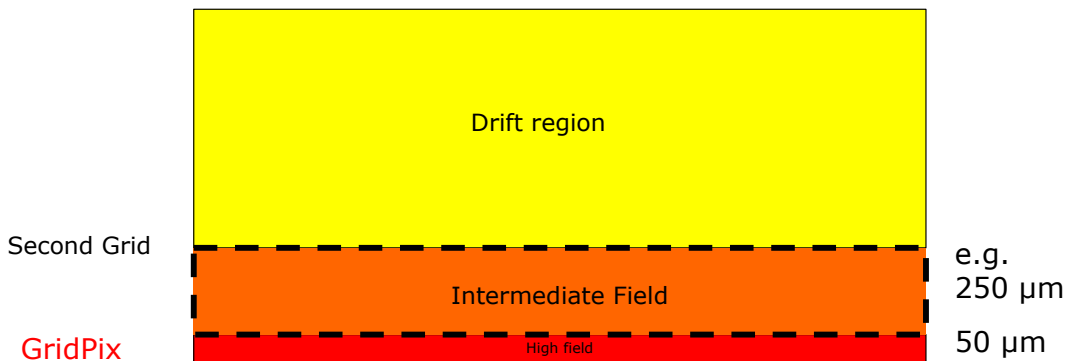

Ion backflow	Hole 30 $\mu\text{m}$	Hole 25 $\mu\text{m}$	Hole 20 $\mu\text{m}$
Top grid	2.2%	1.2%	0.7%
GridPix	5.5%	2.8%	1.7%
Total	$12 \cdot 10^{-4}$	$3 \cdot 10^{-4}$	$1 \cdot 10^{-4}$
transparency	100%	99.4%	91.7%

# Fitting out TPC distortions in ILD

- It is possible to map out distortions using e.g. muons from Z decays
  - E.g. by fitting the 3D space charge distribution as a function of time as was done by ALEPH and more recently by ALICE. Using this distribution the hits positions are corrected and the TPC track refitted.
- However, ILD allows for more elaborate procedures. One can use the track predictions based of the silicon trackers SIT and SET to correct on a track-by-track level the TPC track.
  - One can use as a constraint that the extrapolated positions and angles agree with the measured in the SIT and SET.
  - Practically, one can e.g. correct the TPC track parameters
- The ultimate way is a fitting technique similar to what is developed in ATLAS. In the ATLAS track fit the common systematics is fitted out for sets of Muon hits. For ILD the fit would fit free parameters in the distortion model, while using as a constraint the SIT and SET position and direction measurements.
  - The simplest case is a model where the strength (amplitude) and radial dependence would be scaled and a model is used for the 3D extrapolations.

# Conclusions: Pixel TPC at a circular collider

- YES: a pixel TPC can reconstruct the Z events in one readout cycle
- YES: the current **readout** of the Timepix3 chip can deal with the rate
- The current **power consumption** is  $1\text{W}/\text{cm}^2$ . By running the TPX chips in low power mode this can be reduced by a factor of **10**. Still good **cooling** is important no show stopper; but needs extensive R&D.
- Track distortions in the TPC drift volume are a concern at high lumi Z running:
  - Track distortions from Z decays in TPC are  $O(100)\ \mu\text{m}$
  - It is possible to reduce the IBF for a pixel TPC by making a device with a **double grid**
  - A double grid needs dedicated R&D that can be performed in the new lab in Bonn
- The Z physics program at FCC-ee or CEPC with an ILD-like detector with a Pixel TPC (with double grid structures) sliced between two silicon trackers (VTX-SIT and SET) can be fully exploited. The reduction of beamstrahlung needs more study.
- A pixel TPC can perfectly run at WW, ZH or tt energies where track distortions are several orders of magnitude smaller