

# DRD1 - Work Package 4 - Inner and Central Tracking with PID, TPCs

Diego Gonzalez Diaz, Esther Ferrer Ribas,  
Francisco Garcia, Jochen Kaminski, Piotr Gasik

LCTPC – CM 1  
12.03.2024  
DESY

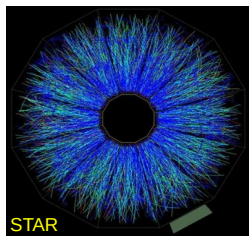

# ECFA Roadmap

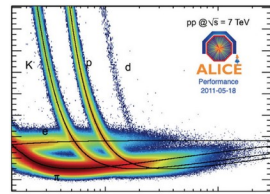

The 2021 ECFA Detector Research and Development Roadmap states the following 4 Detector Research and Development Themes:

**DRDT 1.1 - Improve time and spatial resolution for gaseous detectors with long-term stability.**

**DRDT 1.2 - Achieve tracking in gaseous detectors with  $dE/dx$  and  $dN/dx$  capability in large volumes with very low material budget and different read-out schemes.**

**DRDT 1.3 - Develop environmentally friendly gaseous detectors for very large areas with high-rate capability.**

**DRDT 1.4 - Achieve high sensitivity in both low and high-pressure TPCs.**

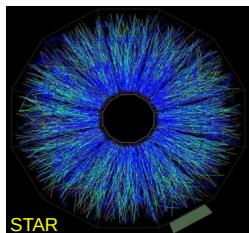

# ECFA Roadmap

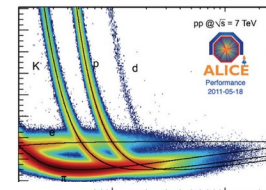

Breakdown of challenges into amplification technologies, detector types and experiments

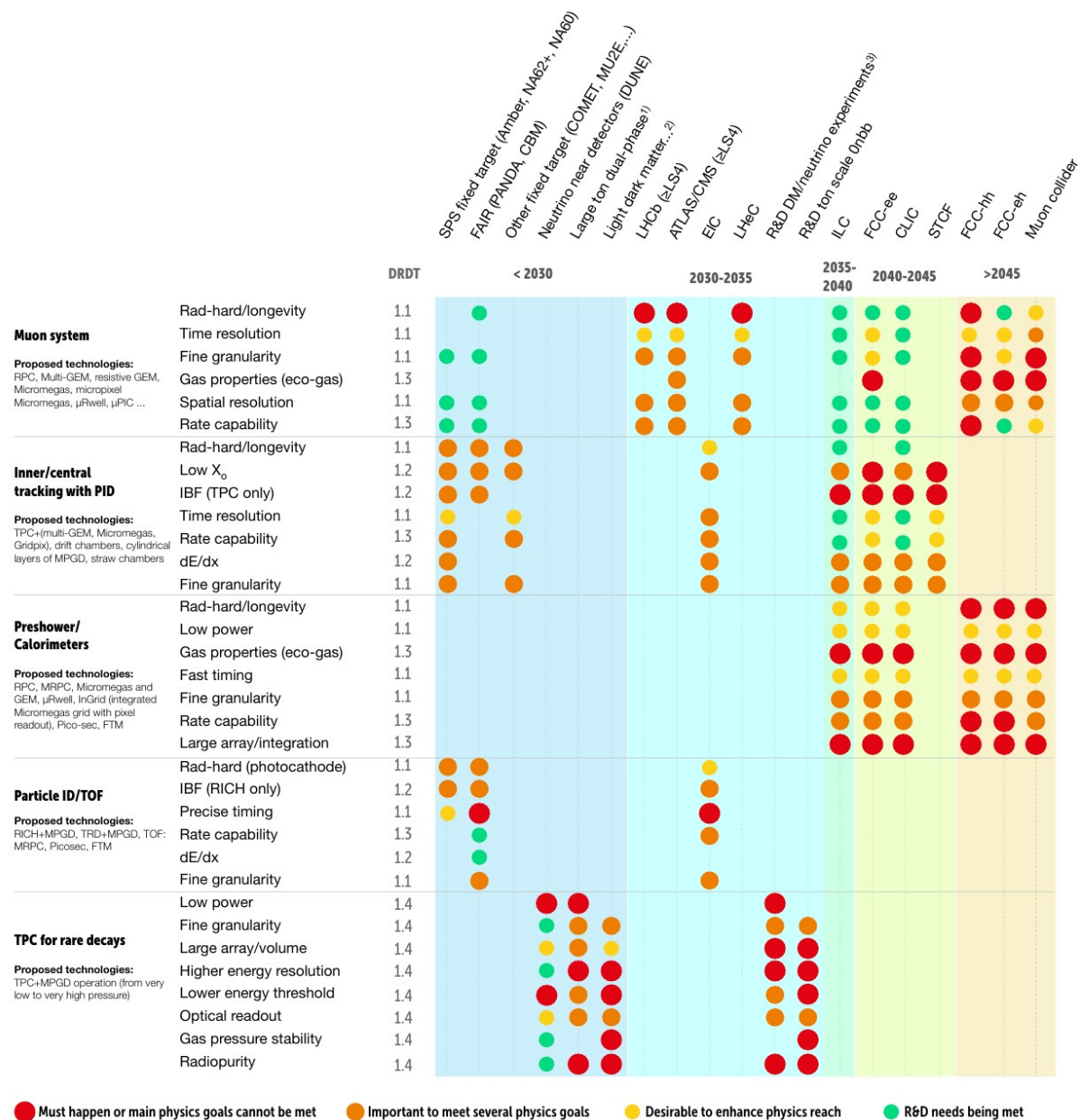

1) Large ton dual-phase (PandaX-4T, LZ, DarkSide -20k, Argo 200k, ARIADNE, ...)  
 2) Light dark matter, solar axion, Onbb, rare nuclei&ions and astro-particle reactions, Ba tagging)  
 3) R&D for 100-ton scale dual-phase DM/neutrino experiments

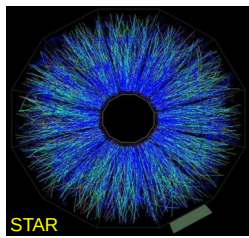

# DRD1

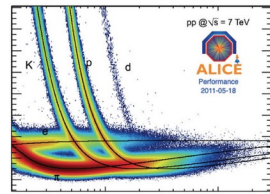

10.11.2022 first meeting of DRD1 formation working group

01.2023 preparation and implementation of a community survey

04.2023 proposal writing start

15.07.2023 proposal submission

07.-11.2023 proposal adaption to input of DRDC (final **DRD1 proposal**)  
Formation of work packages

04.12.2023 approval of DRD1 by the CERN Research Board

20.12.2023 election of spokespersons (M. Titov, E Oliveri) and  
collaboration board chair (A. Colaleo)

29.01.-02.02.2024 first Collaboration Meeting

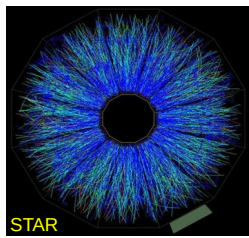

# DRD1

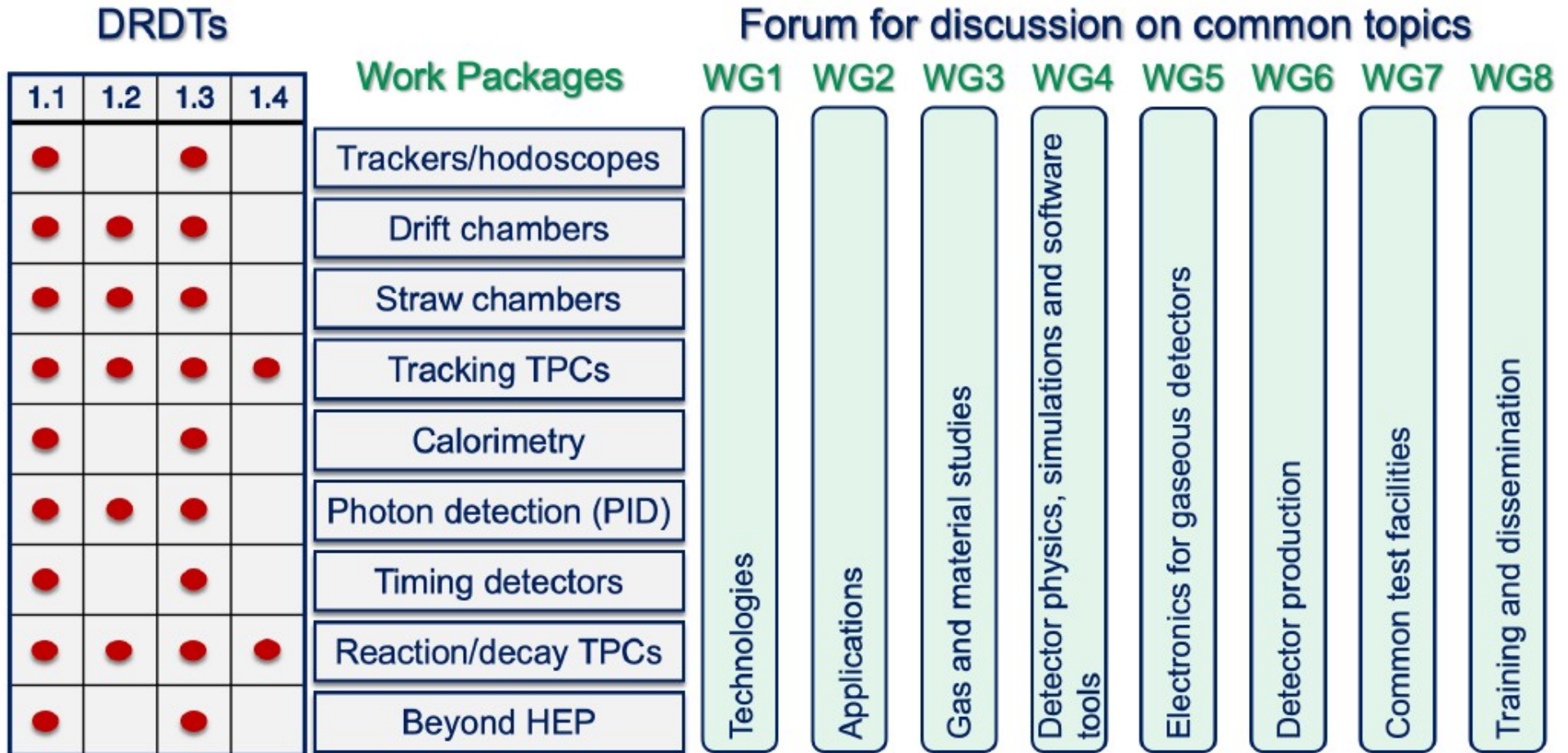
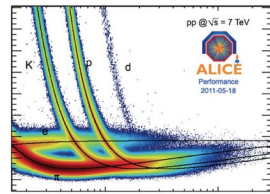
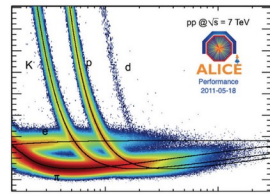
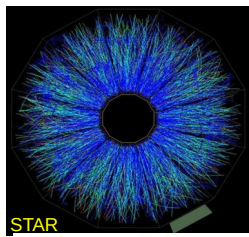

Figure 2: DRD1 Scientific Organization





# The DRD1 Proposal

Great DRD1 community teamwork, allowed to shape the “legacy document” for the gaseous detectors domain for decades to come



## DRD1 EXTENDED R&D PROPOSAL Development of Gaseous Detectors Technologies v1.5

### Abstract

This document, realized in the framework of the newly established Gaseous Detector R&D Collaboration (DRD1) presents a comprehensive overview of the current state-of-the-art and the challenges related to various gaseous detector concepts and technologies. It is divided into two key sections.

The first section, titled “Executive summary”, offers a broad perspective on the collaborative scientific organization, characterized by the presence of eight Working Groups (WGs), which serve as the cornerstone for our forthcoming scientific endeavours. This section also contains a detailed inventory of R&D tasks structured into distinct Work Packages (WPs), in alignment with strategic R&D programs that funding agencies may consider supporting. Furthermore, it underlines the critical infrastructures and tools essential for advancing us towards our technological objectives, as outlined in the ECFA R&D roadmap.

The second section, titled “Scientific Proposal and R&D Framework,” delves deeply into the research work and plans. Each chapter in this section provides a detailed exploration of the activities planned by the WGs, underscoring their pivotal role in shaping our future scientific pursuits. This DRD1 proposal reinforces our unwavering commitment to a collaborative research program that will span the next three years.

Geneva, Switzerland

December 1, 2023<sup>†</sup>

<sup>\*</sup>DRD1 Website: <https://drd1.web.cern.ch/>

<sup>†</sup>Last modification on January 28, 2024 (New institutes added)

[Submitted to CDS \(2024-01-9\)](#)

[Updated to DRD1 web \(2024-1-28\)](#)

- >700 participants from 161 institutes in 33 countries
- + 5 Industrial, Semi-Industrial partners and Research Foundations

Approved by CERN Research board on 6th December!

A. Colaleo

4

04.12.2023

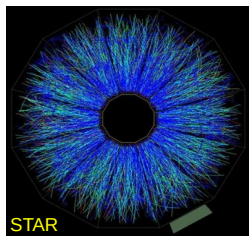

# WP4 vs. WP8

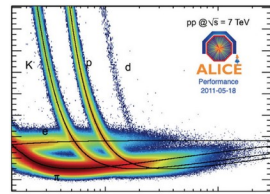

**WP4:** Inner and central tracking with PID → classical HEP-TPCs at colliders  
e.g. Aleph, Delphi, ALICE, STAR, etc.

**WP8:** TPCs as reaction and decay chambers → rare event detectors  
e.g. Cygnus

But what about, if it is not that obvious? What about nuclear-physics TPCs, neutrino TPCs, etc? → Currently, we defined the following separation line:

If the TPC is only for tracking and PID of particles generated outside of the detector, the experiment belongs to WP4.

If the TPC(-gas) is part of the active material, that is, if it is needed for the physics process under study to take place, the experiment belongs to WP8.

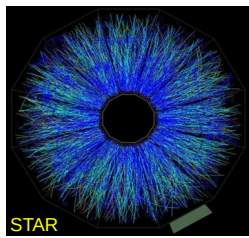

# Who we are

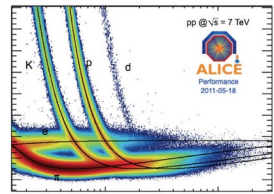

The preliminary conveners, who were selected for the drafting process, are

Diego Gonzalez Diaz (Universidade de Santiago de Compostela)  
diego.gonzalez.diaz@cern.ch,

Esther Ferrer Ribas (Université Paris-Saclay)  
esther.ferrer-ribas@cea.fr,

Francisco Garcia (Helsinki Institute of Physics)  
francisco.garcia@cern.ch,

Jochen Kaminski (University of Bonn)  
kaminski@physik.uni-bonn.de,

Piotr Gasik (GSI - Helmholtzzentrum für Schwerionenforschung GmbH)  
p.gasik@cern.ch



Diego



Esther



Francisco

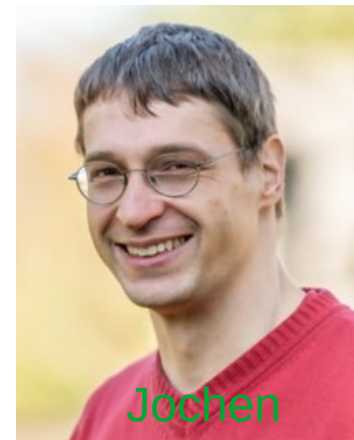

Jochen

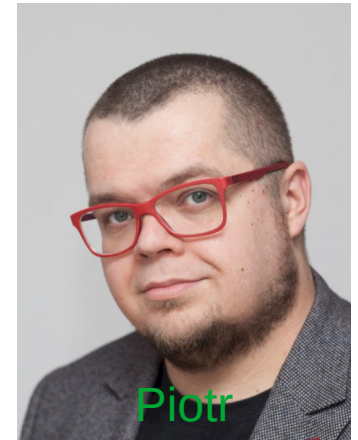

Piotr



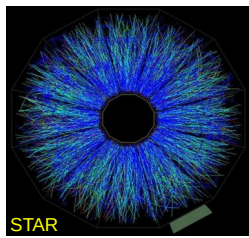

# TPC Challenges

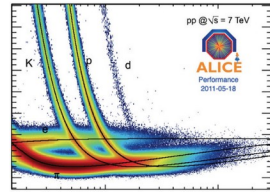

## Detector Research and Development Themes:

**DRDT 1.1 - Improve time and spatial resolution for gaseous detectors with long-term stability.**

**DRDT 1.2 - Achieve tracking in gaseous detectors with  $dE/dx$  and  $dN/dx$  capability in large volumes with very low material budget and different read-out schemes.**

**DRDT 1.3 - Develop environmentally friendly gaseous detectors for very large areas with high-rate capability.**

**DRDT 1.4 - Achieve high sensitivity in both low and high-pressure TPCs.**

All four themes are relevant for the future developments of TPCs and therefore are priority topics in this work package.

We have therefore identified 5 common challenges for designing and building a TPC for a new experiment. These have been summarized in 5 tasks.

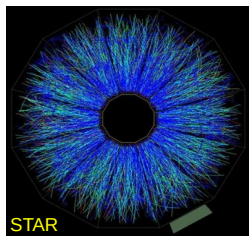

# Task 1: IBF Reduction

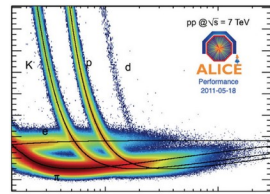

Ion backflow reduction is the most challenging task for every TPC. Future experiments at high rates will require a continuous read out excluding the option of active gating. Therefore, the task started by the ALICE collaboration should be continued and new ideas should be developed and studied aiming for values of  $\text{gain} \times \text{IBF} < 1-5$ .

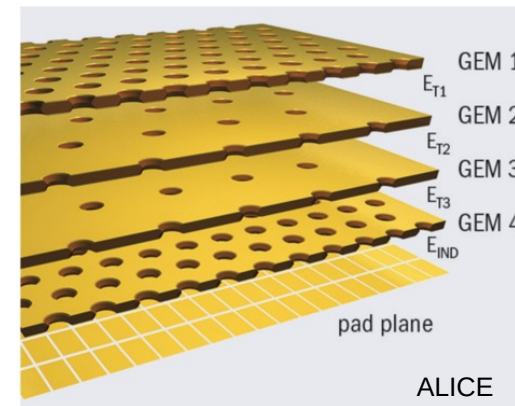
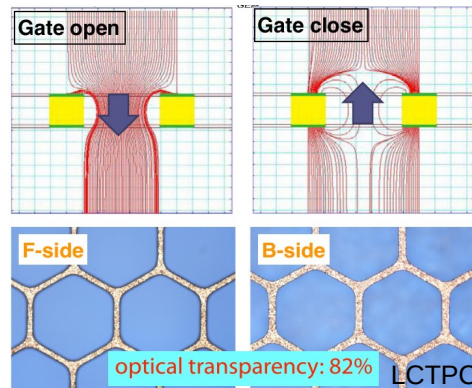

**Description of task:** Ion Backflow is defined as the number of ions reaching the drift volume over the number of ions created in the gas amplification. To minimize the electrical field distortions in the drift volume, the IBF has to be as low as possible. Depending on the experimental requirements active or passive measures to reduce the IBF can be taken. Most challenging is the passive reduction as only static fields can be used to guide the ions. This is necessary for a continuous readout of TPCs. In this task both approaches shall be studied to find solutions for both options.

# Task 2: Development of pixelTPC

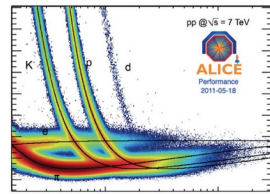
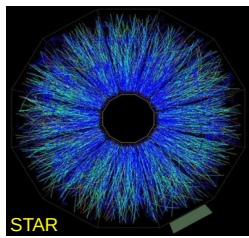

A highly pixelized readout, where a large fraction of single primary electrons can be resolved, is a very promising candidate for future experiments as a maximum of space and  $dE/dx$  information can be gained. Building and operation of such devices is very challenging and therefore different ideas will be tested and discussed. Also the IBF of these devices has to be optimized (overlapping with task 1.)

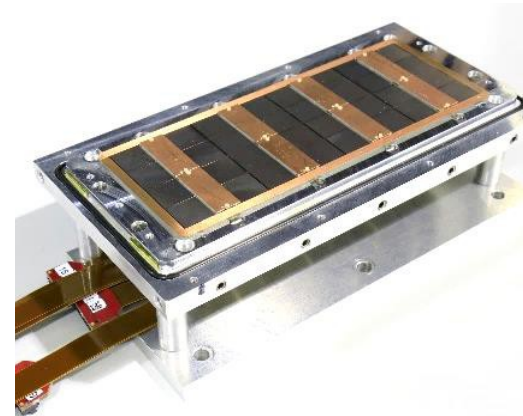
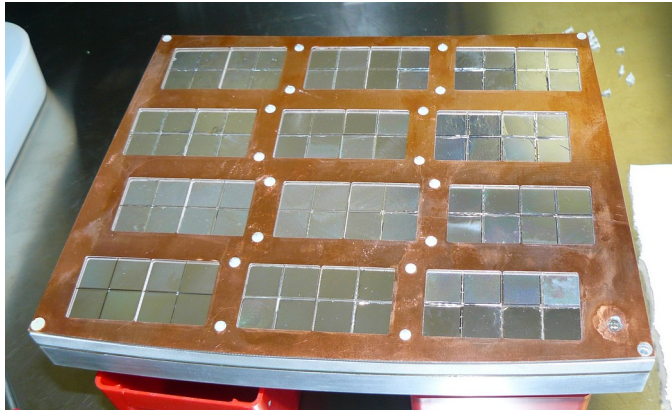

**Description of task:** A highly pixelized TPC readout promises the best possible resolution in both space and energy only limited by the diffusion. Therefore, this approach should be studied in more detail in this task. Various approaches will be tested and the structures shall be optimized with respect to resolution and IBF.

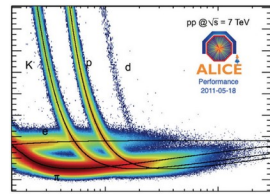
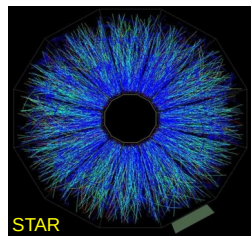

# Task 3: Optimization of the amplification stage and its mechanical structure, and development of low $X/X_0$ field cages

In this task mostly mechanical aspects are considered to further improve the strong points of TPCs like very low and homogenous material budget, how to integrate cooling and powering in an endplate, etc. Possible ideas are to investigate a resistive layer (CVD?) as field cage and to study materials for insulation and mechanical stability of both the cylinder as well as the endcap.

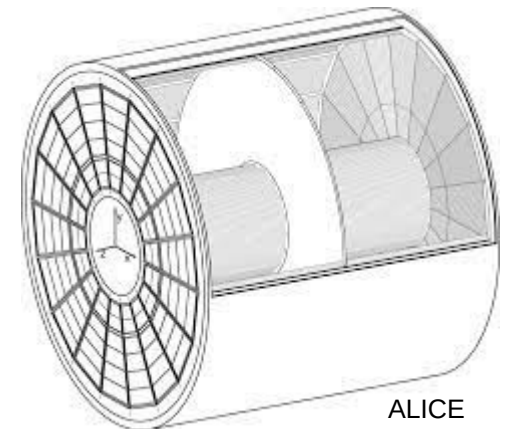

**Description of task:** One additional advantage of TPCs is their light and homogenous structure. Filled only with gas, they have no mechanical structures except the field cage (here both the electrical and mechanical aspects are referred to) and the endcaps. In this task new ideas shall be developed and investigated to further **increase the homogeneity of the FC and to lower the material budget of both components.**



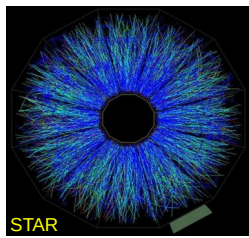

# Task 4: FEE for TPCs

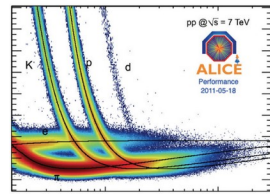

In particular many smaller experiments suffer from the lack of suitable electronics. We, therefore, suggest to find / design + produce / implement / buy and test suitable ASICs, which can read out a TPC and then implement them in the SRS, which is a wide spread readout system used by many groups already. In this way, electronics for small experiments or lab tests and lab setups would be available for all groups.

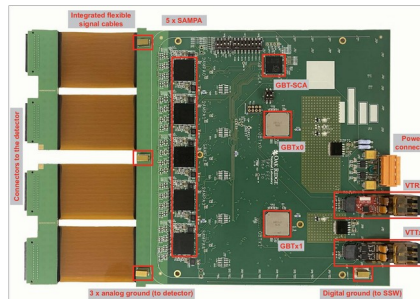

SAMPA-based readout electronics of ALICE, CERN

**Description of task:** The traditional TPC readout is based on a continuous sampling of the baseline and signals after an event trigger. This concept is not applicable any more for a **continuous readout, but a self-triggered zero-suppressed readout** has to be used. Nevertheless, **sampling of the signals** is highly favored to identify double tracks, measure  $dE/dx$  more precisely and to get hints of the longitudinal diffusion. Standard tracking electronics does not fulfill these requirements and dedicated TPC electronics is necessary. Most of this electronics, however, is experiment specific and not easily available and usable. Therefore, this task is dedicated to develop an SRS-based readout system for smaller scale experiments and test setups with TPCs. It also includes the development of **low power electronics and Front End Electronics cooling**.

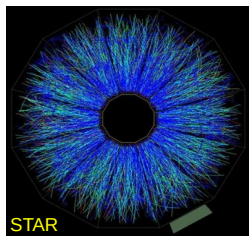

# Task 5: Gas Mixture

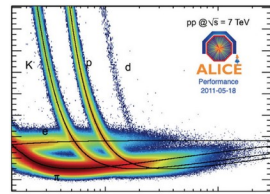

Requirements on the gas are usually driven by the experimental setup and the physics requirements.

We will therefore contribute to the gas database planned in WG 3 with a specific focus on typical TPC aspects like low transverse diffusion. Also, environmental impact and gas pressure are of interest.



**Description of task:** Because of the long drift distances (up to 2.5 m) specific gas mixtures with **low diffusion** coefficients are needed to improve the spatial resolution of a TPC. As most tracking TPCs are embedded in a magnetic field parallel to the electric drift field, gases with a **high  $\omega\tau$**  are sought, because the transverse diffusion is suppressed in this configuration. In this task new gases suitable for TPC applications are studied. A particular attention will be given to a **low environmental impact** (e.g. low GWP) and the effect of **varying the gas pressure** will also be studied.

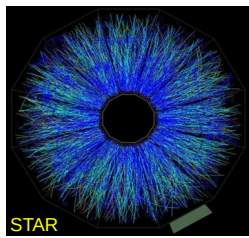

# Deliverables and Milestones

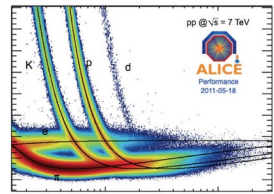

D1. Demonstrator MPGD-TPC commissioned for studies of tracking performance at high rates using different types of amplification stages and readout electronics. This deliverable is related to the assembling of a TPC prototype, using any type of MPGD amplification stages and also readout electronics, to target high rate capability. This was based on the feedback given by most of the groups, where it was stated the assembling of various types of MPGD- based TPCs.

The main idea behind this deliverable is to group all the different prototypes into one, which can be available for different tracking studies and in synergy with the groups involved.

D2. Report on Ion backflow studies as a function of particle rate including measurements and simulations for its reduction.

D3. Report on the tracking performance with using high density readout electronics and different readout structures with large dynamic range.

D4. Construction of new highly pixelized readout structures.

D5. Develop new high-density electronics for TPCs for both pixelized and standard pad readout with low-power consumption, low noise, high dynamic range and Cooling.

M1. Demonstrator MPGD-TPC produced and ready to be commissioned.

M2. Setup for IBF measurements are ready to measure.

M3. Prototype including readout structure and electronics ready for test beam.

M4. First prototypes of pixelized structures - not necessarily functional.

M5. First prototype of next generation FEC produced.

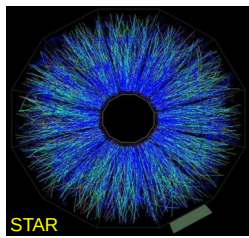

# Participating Institutes

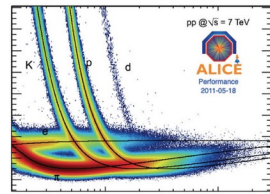

Universidade de São Paulo (USP)  
Carleton University (U Carleton)  
Institute of High Energy Physics (IHEP/CAS)  
Tsinghua University (U Tsinghua)  
Helsinki Institute of Physics (HIP)  
University of Jyväskylä (U Jyväskylä)  
IRFU, CEA, University Paris-Saclay (IRFU/CEA)  
University of Bonn (U Bonn)  
Technische Universität Darmstadt, Institut für Kernphysik (TUDa)  
GSI Helmholtzzentrum für Schwerionenforschung (GSI)  
Wigner Research Centre for Physics (RCP)  
INFN Sezione di Bari (INFN-Bari)  
INFN Sezione di Roma (INFN-Roma1)  
Iwate University (IU)  
European Organisation for Nuclear Research (CERN)  
Paul Scherrer Institut (PSI)



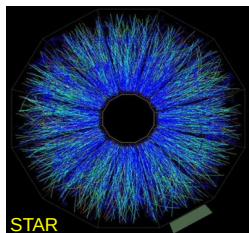

# Interest of Participants in Tasks

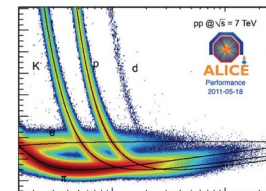

Institute	T1	T2	T3	T4	T5
USP				x	
U Carleton	x	x			
IHEP/CAS	x	x		x	x
U Tsinghua				x	
HIP	x		x		x
U Jyväskylä	x				
IRFU/CEA	x			x	
U Bonn	x	x		x	x
TUDa	x		x		
GSI	x			x	x
RCP	x				
INFN-Bari			x		x
INFN-Roma1	x	x			
IU	x		x		
CERN		x			
PSI	x	x			

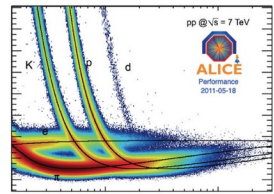
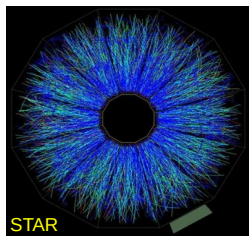

## To state the obvious:

Everything is still preliminary: tasks, deliverable and milestones are not final and can still be extended, redefined or added.

In particular more institutes are very welcome !!!!!!!!!!!

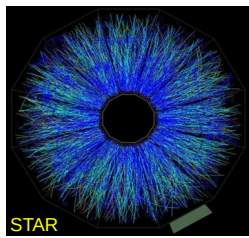

# Next Steps

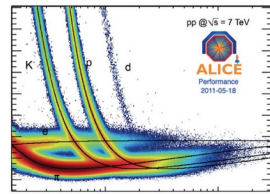

Everyone interested in the work package should subscribe to the e-group:

**drd1-wp4**

Self-subscription is be possible.

I suggest we will have a first zoom-meeting in a few weeks to discuss the structure of the work package and other subjects. Invitations will be distributed via the e-group.

WP4 web page: <https://drd1.web.cern.ch/wp/wp4>

Email list of WP4 coordinators: [drd1-wp4-contacts](#)