

Developing KinkFinder at ILC

Work in progress

Jurina Nakajima, Daniel Jeans

SOKENDAI

2024/07/10



The motivation and aim of my study

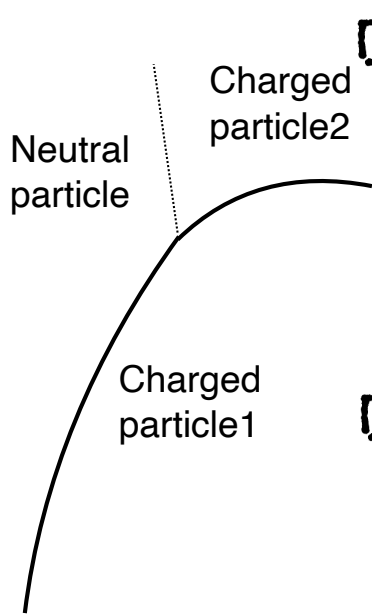

□ What is kink?

A charged particle decays and produces another charged particle.

Then the track bends abruptly and it is called “**kink**”.

□ Why do I focus on kinks?

The kink is a signature of Long Lived Particles (LLPs) for New physics.

Ex. Chargino decays into a SM charged particle and a neutralino (Lightest SUSY Particle) etc...



I focus on kinks decayed inside a tracking detector, I'd like to identify kinks efficiently and accurately.

How do I identify kinks? - KinkFinder

in MarlinReco/Tracking/KinkFinder

I want to study kinks from LLPs but firstly I try to check “standard kinks” from **SM particles (eg. Kaon...)**

2 tracks with

- ▶ Same sign
- ▶ Different momenta
- ▶ Small distance of closest approach

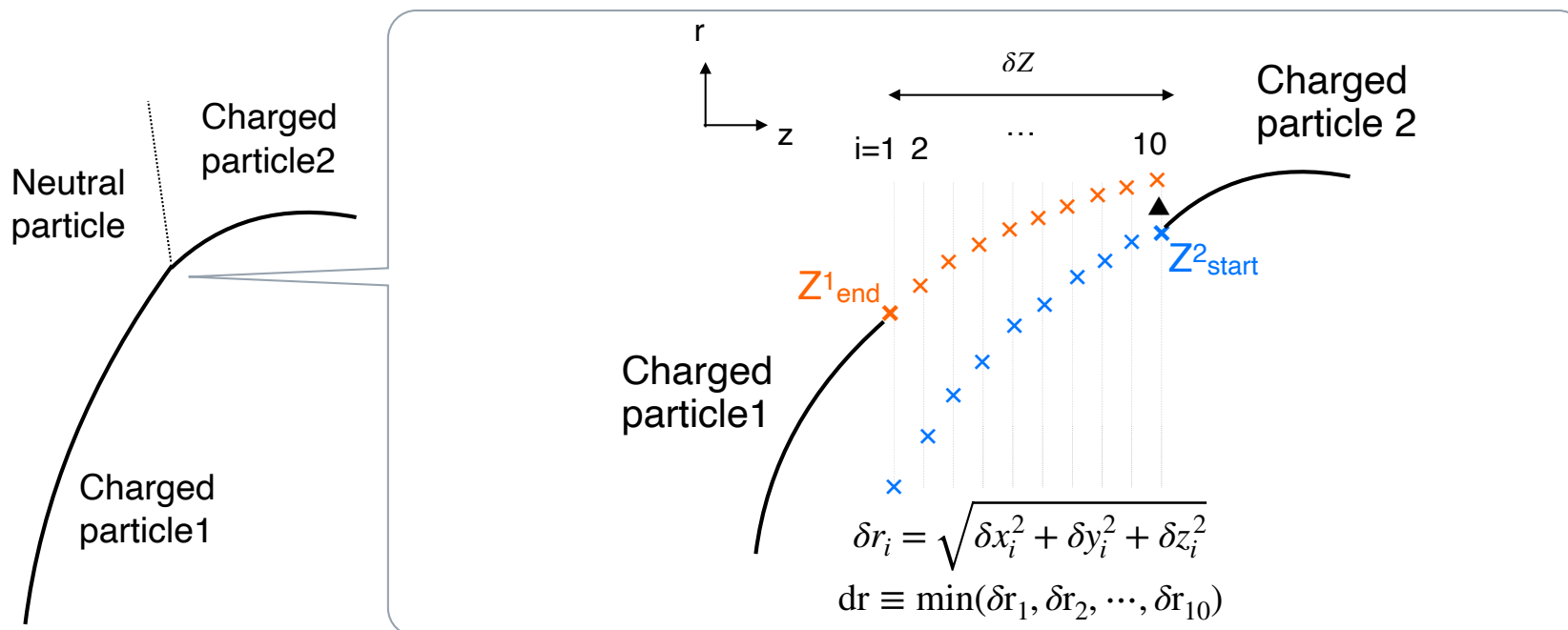

Kaon

10GeV Kaons simulated and reconstructed in ILD_I5_v02 (CALOS removed)

1. $K^- \rightarrow \mu^- \nu_\mu$

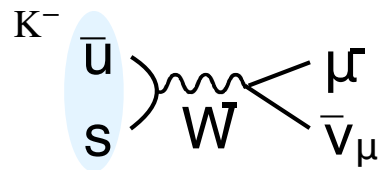

2. $K^- \rightarrow \pi^- \pi^0$

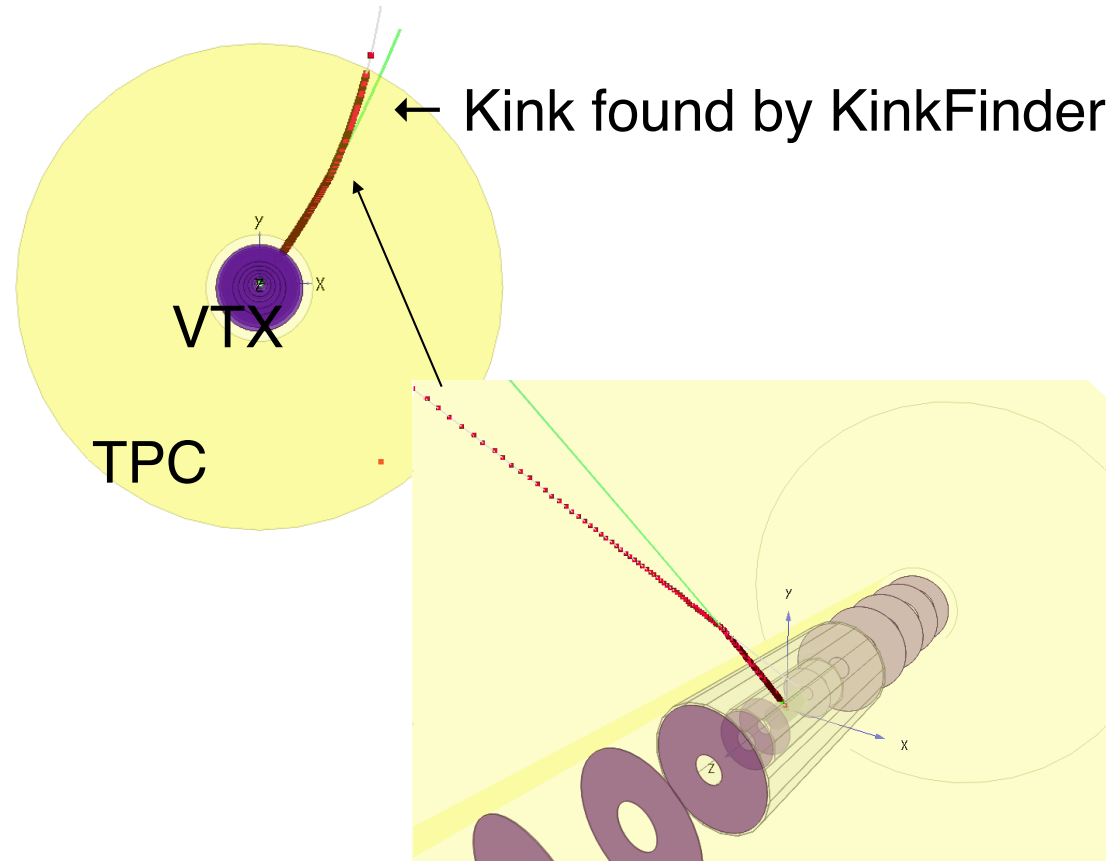
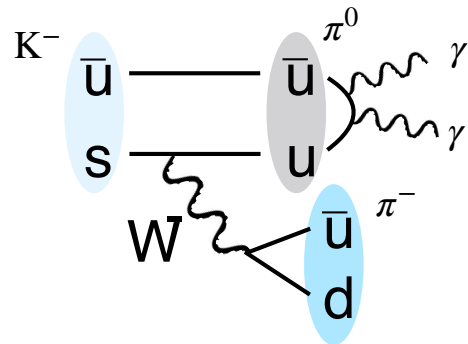

I checked the efficiency of KinkFinder.

Efficiency dependence on the kink angle

Precut made from MCparticles

- Endpoint(MC) inside TPC:
 $329 + 100 < r < 1770 - 100$ [mm] , $|z_{max}| < 2350 - 250$ [mm]
- (MC) # of charged daughter of Kaon = 1

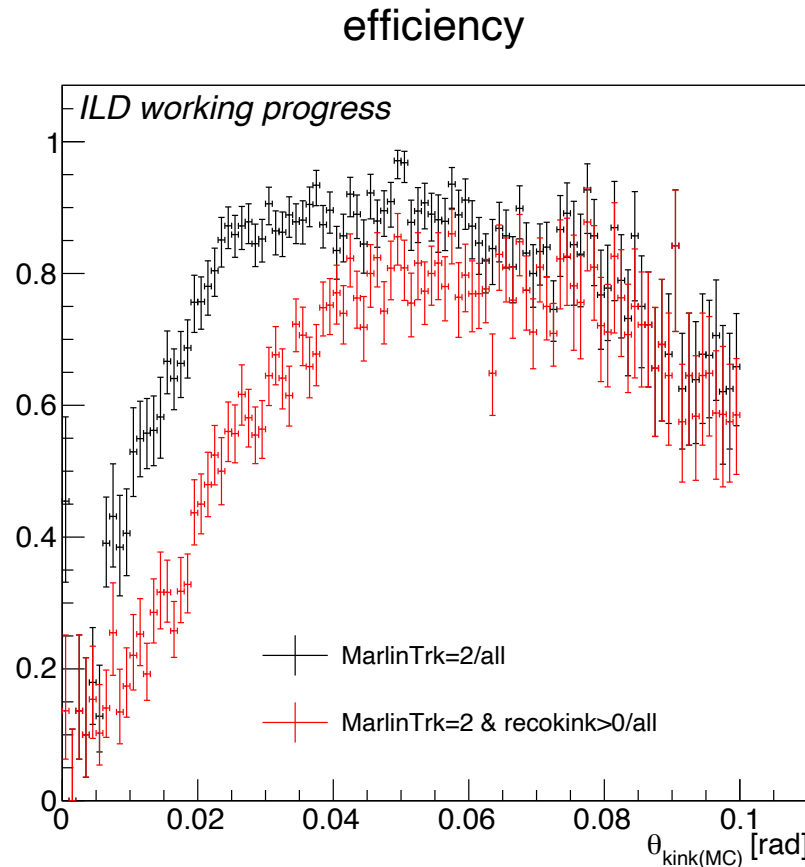
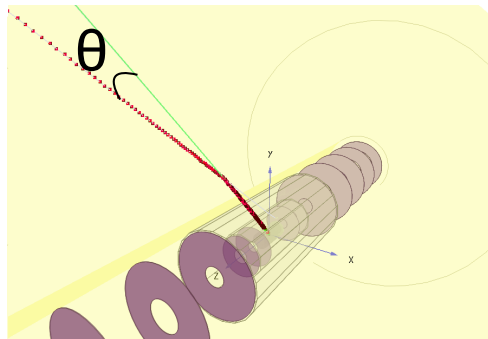
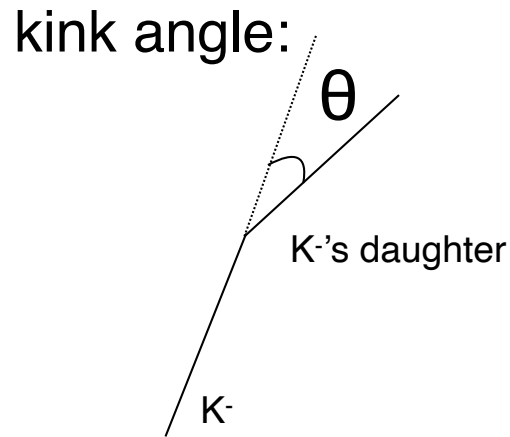
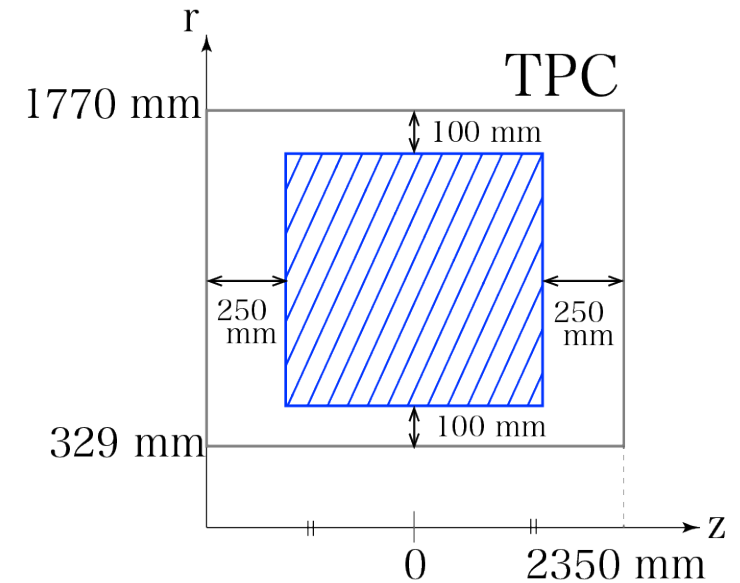

all: imposing only precut

Black: nTrack = 2 (tracking efficiency)

Red: nTrack =2 and Kink > 0 (tracking and KinkFinding efficiency)

KinkFinder efficiency $\sim 80\%$ ($0.04 < \theta_{\text{kink(MC)}} < 0.08$)

Efficiency dependence on the kink angle

Precut made from MCparticles

- Endpoint(MC) inside TPC:
 $329 + 100 < r < 1770 - 100$ [mm] , $|z_{max}| < 2350 - 250$ [mm]
- (MC) # of charged daughter of Kaon = 1

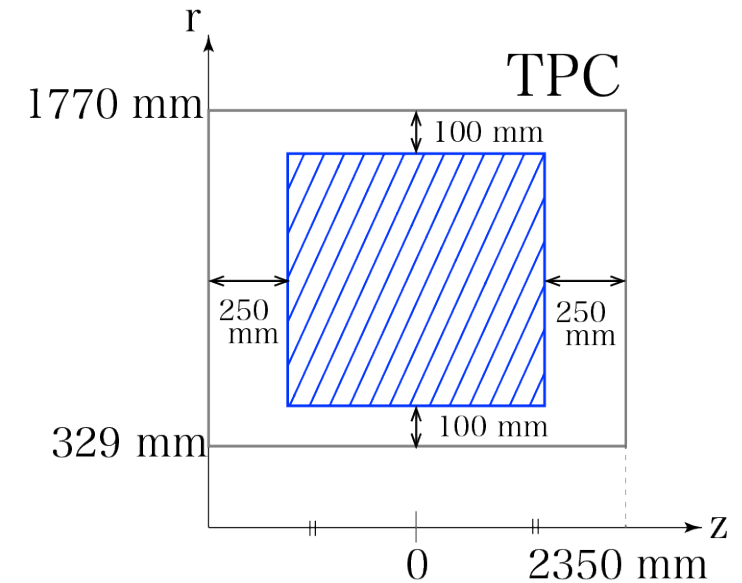
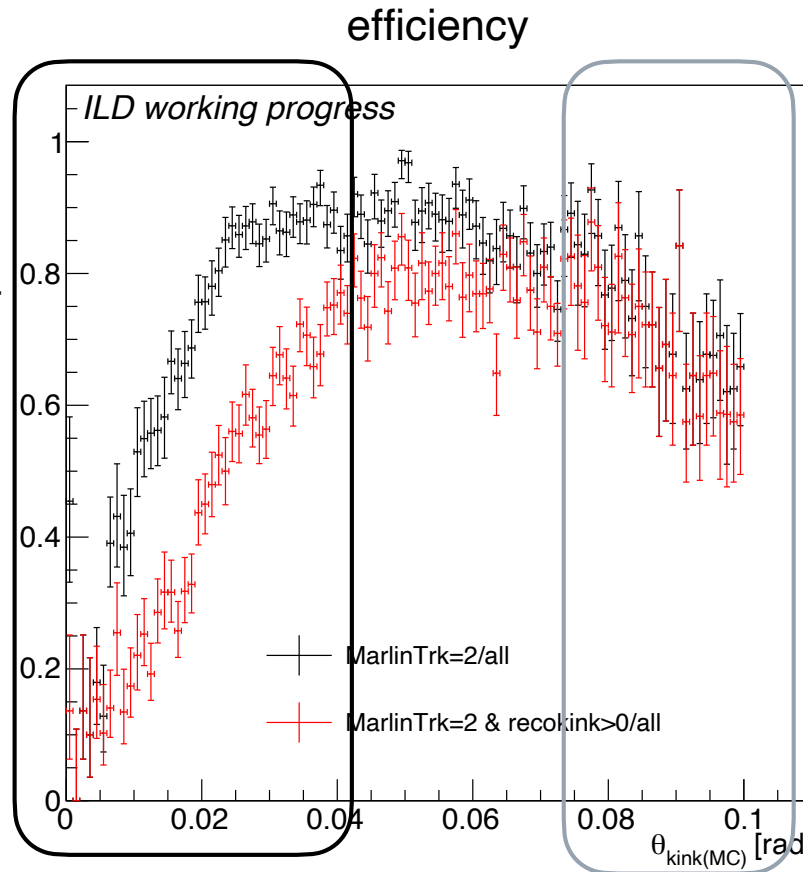
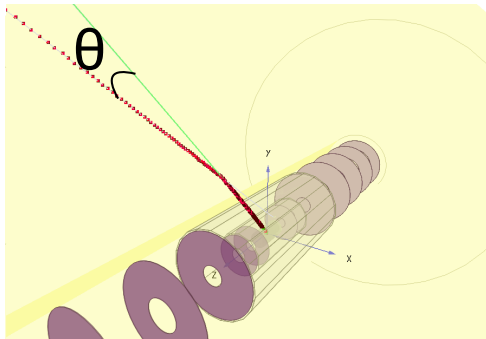
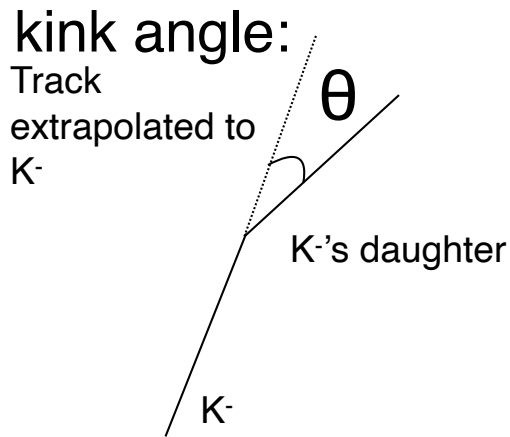

all: imposing only precut

Black: $nTrack = 2$ (tracking efficiency)
 Red: $nTrack = 2$ and $Kink > 0$ (tracking and KinkFinding efficiency)

Merged into **single** track?

Efficiency for very displaced 2nd track?

More particles - Kaon, Pion, Sigma, Xi

10GeV particles simulated and reconstructed in ILD_I5_v02

Estimated mass of kink's parent particle

What is kink mass? which particle produced kink?

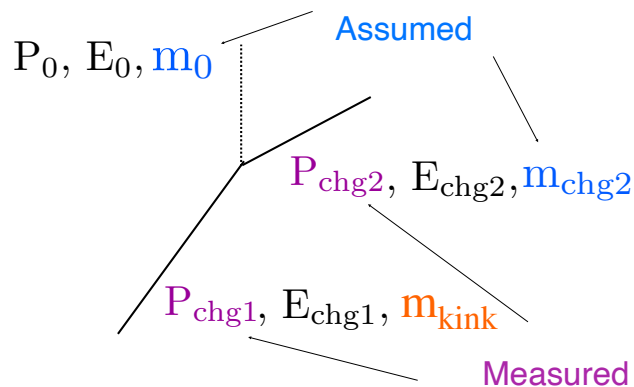

fig.Schematic of kink

Using $P_0 = P_{\text{chg1}} - P_{\text{chg2}}$, (Momentum conservation)

$$E_0 = \sqrt{P_0^2 + m_0^2} = \sqrt{(P_{\text{chg1}} - P_{\text{chg2}})^2 + m_0^2}$$

$$E_{\text{chg2}} = \sqrt{P_{\text{chg2}}^2 + m_{\text{chg2}}^2} \quad \text{(Energy conservation)}$$



$$m_{\text{kink}} \equiv \sqrt{(E_{\text{chg2}} + E_0)^2 - P_{\text{chg1}}^2}$$

Table 1. Tested kink decay in standard kinkfinder

	m_{chg2}	m_0
$\pi^\pm / K^\pm \rightarrow \mu^\pm \nu$	m_μ	0
$K^\pm \rightarrow \pi\pi$	m_π	m_π
$\Sigma^+ / \Sigma^- \rightarrow \pi n$	m_π	m_n
$\Sigma^+ \rightarrow p\pi_0$	m_p	m_π
$\Xi^- \rightarrow \pi\Lambda$	m_π	m_Λ

Choose best decay hypothesis using kink mass

How to get momentum information

KinkFinder

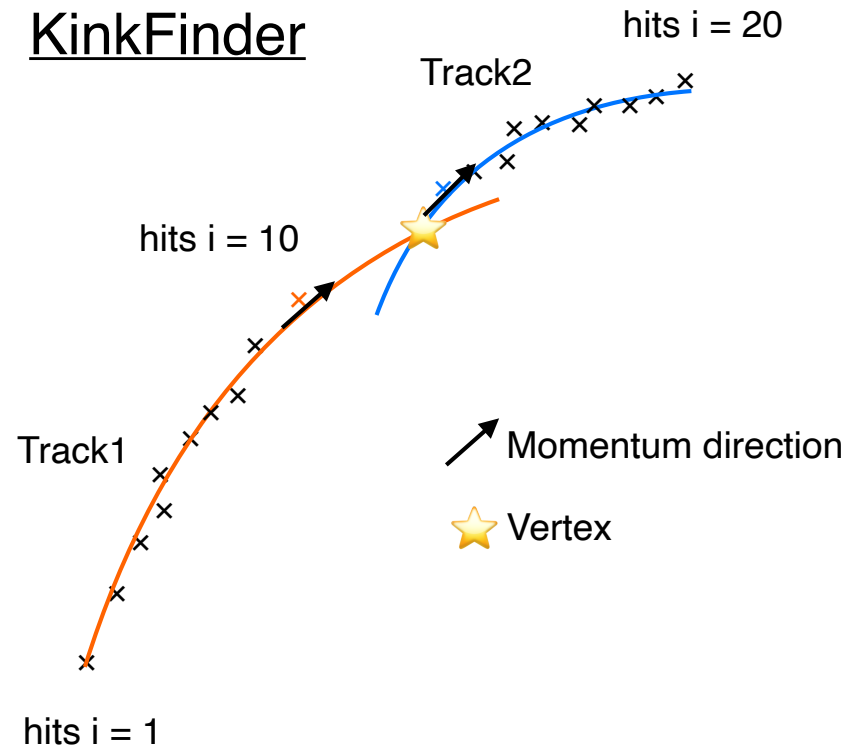

Fit first / last 10 hits to helix
Helix momentum at last/first hits

Momentum at vertex

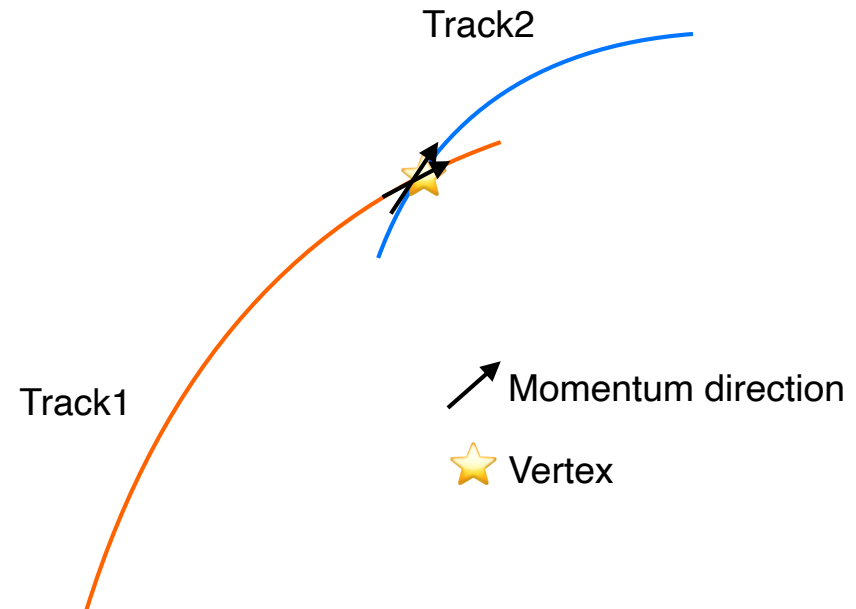

Use full track fits
trackstate momentum at
reconstructed vertex

Comparison of δm distribution

$$\delta m_{\text{kink}} \equiv m_{\text{reco}_K} - m_{\text{true}_K}$$

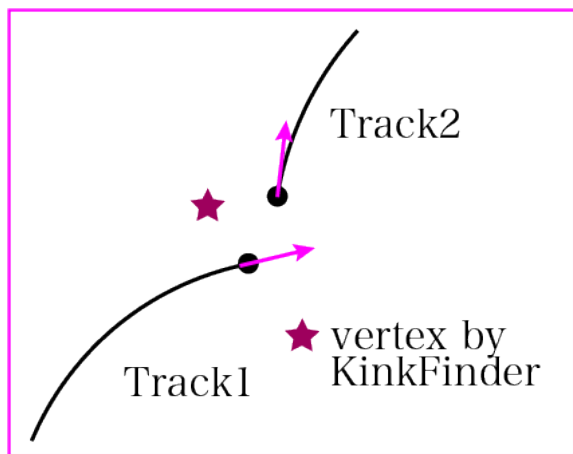

$\delta m_{\text{kink}} (K^- \rightarrow \mu^- \bar{\nu})$

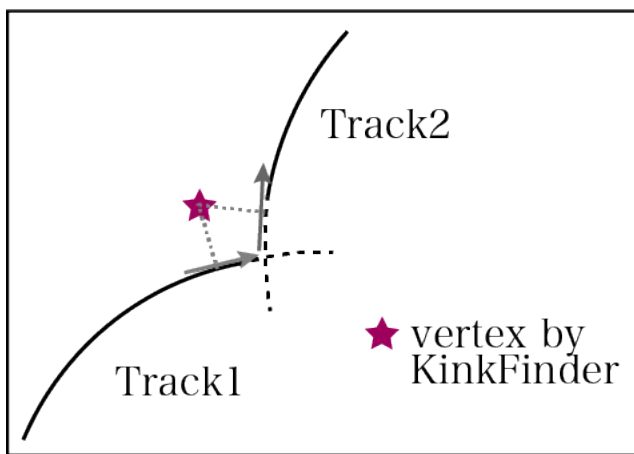

$\delta m_{\text{kink}} (\pi^- \rightarrow \mu^- \bar{\nu})$

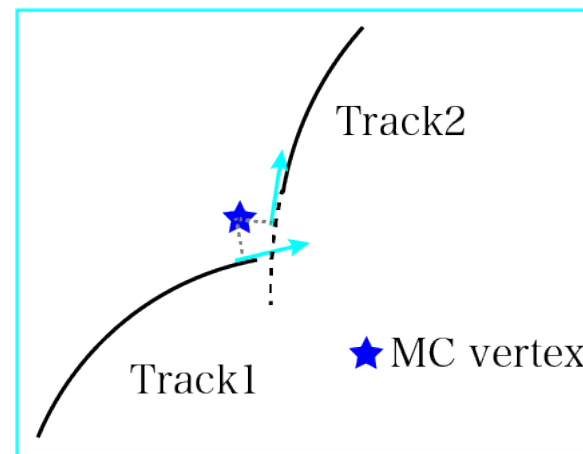

$\delta m_{\text{kink}} (\Xi^- \rightarrow \pi^- \Lambda)$

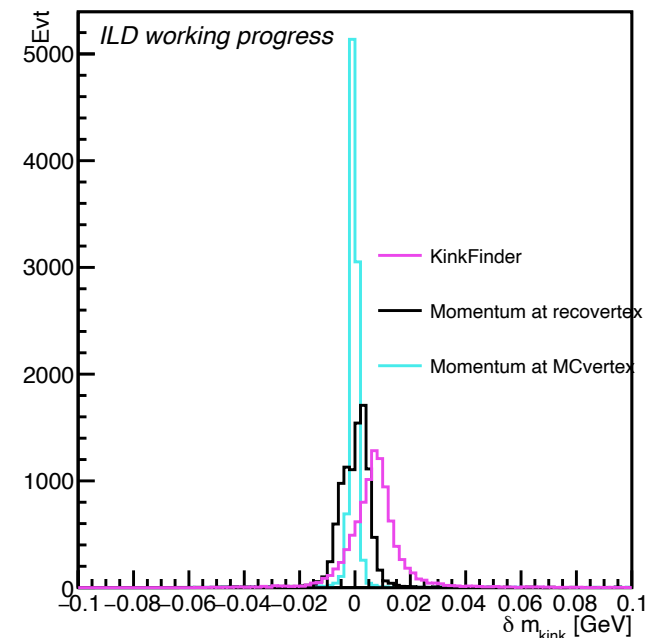
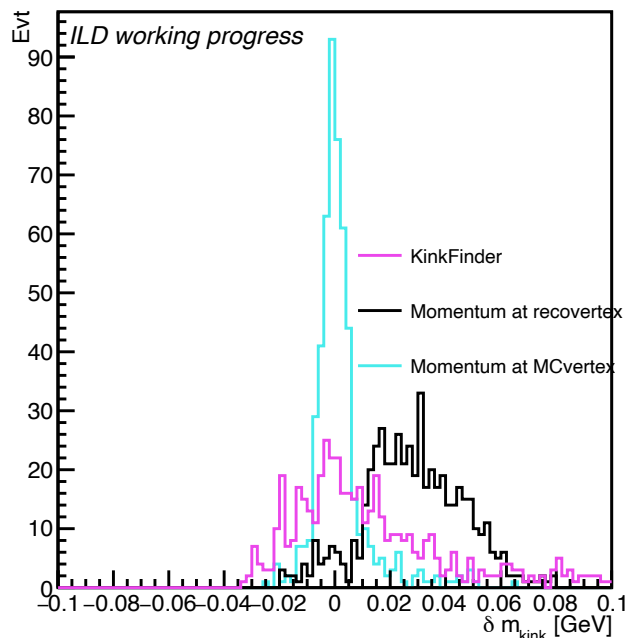
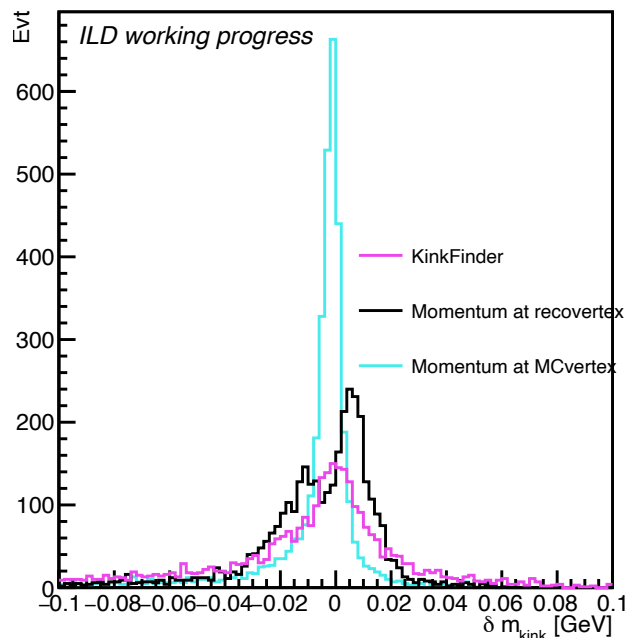

Vertex reconstruction improved
 → δm distribution is improved !

Marlintrk bias at vertex

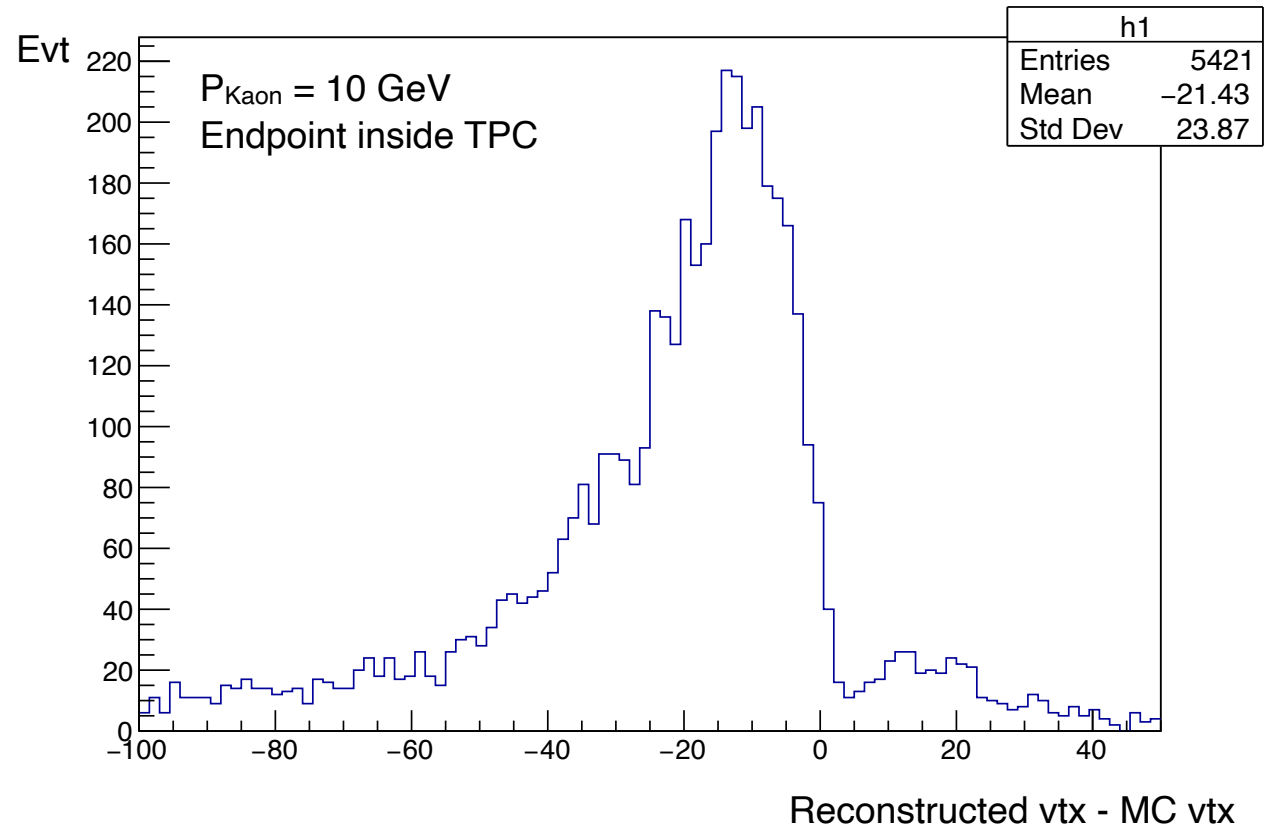
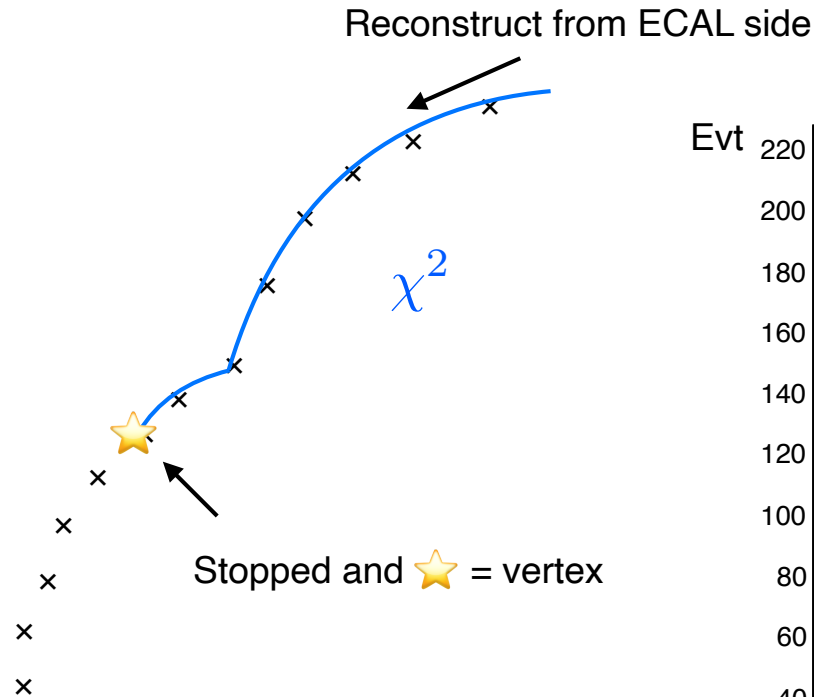

In Marlin track reconstruction, when χ^2 become too large, tracking is stopped.

-> vertex is biased to smaller radius.

How to get vertex information

New version

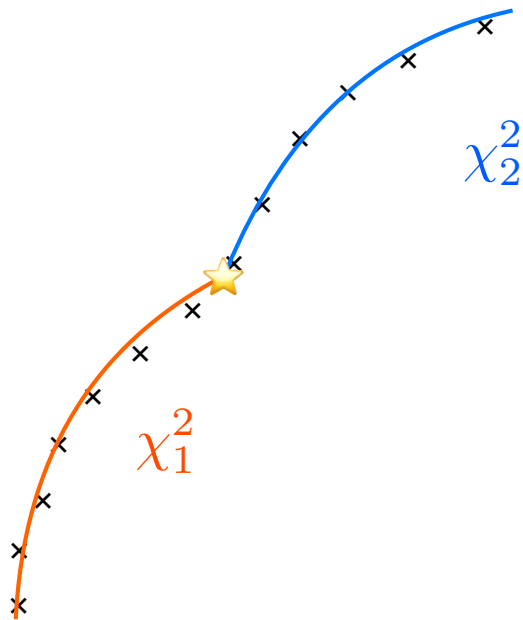

chiSq-trk1
+
chiSq-trk2

I try to cut track at each hit's position,
calculate $\chi_1^2 + \chi_2^2$

The hit corresponding to minimum
 $\chi_1^2 + \chi_2^2$ is assumed as the kink position.

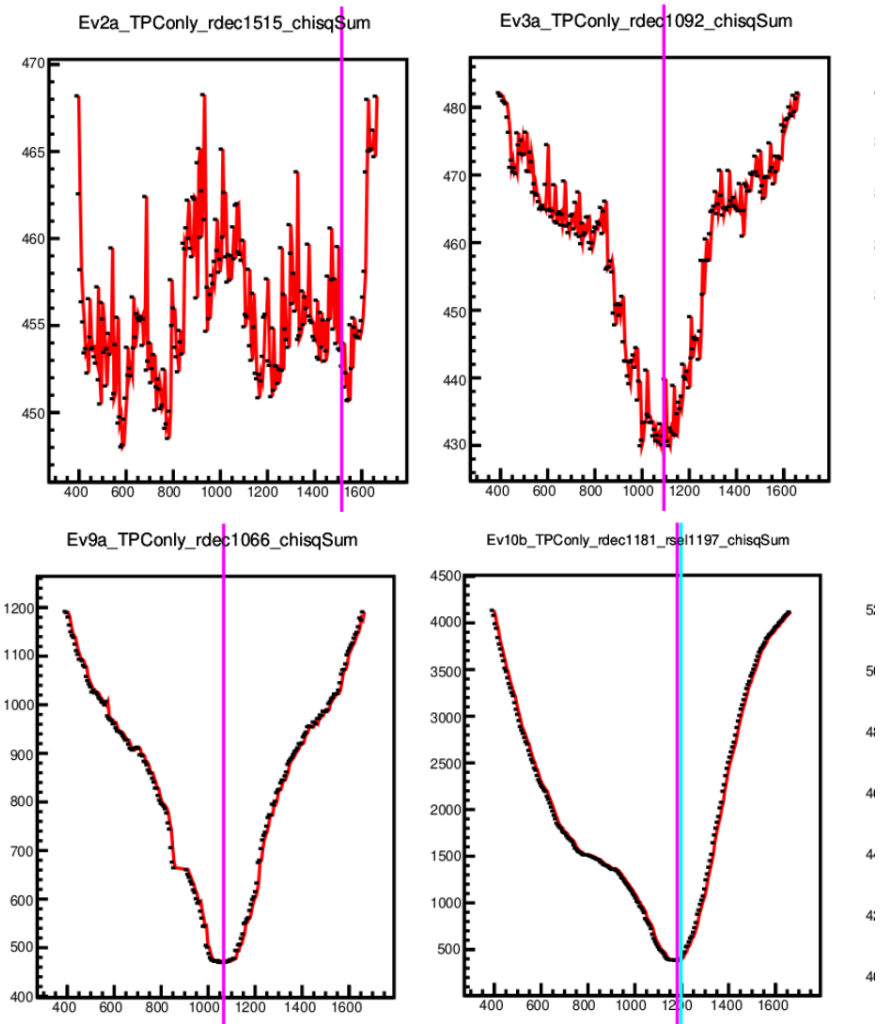

Figures by Daniel

Comparison of δm distribution - new!

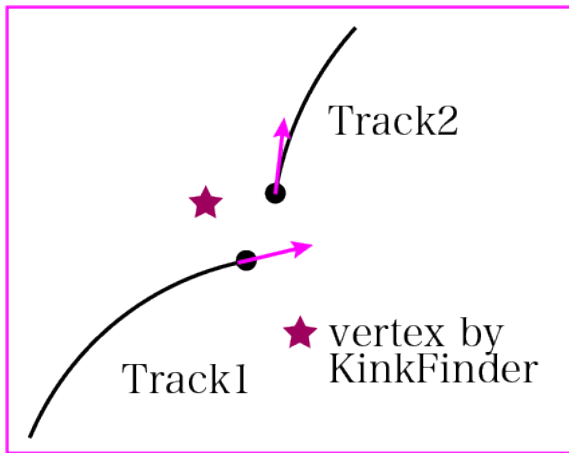

$\delta m_{\text{kink}} (K^- \rightarrow \mu^- \bar{\nu})$

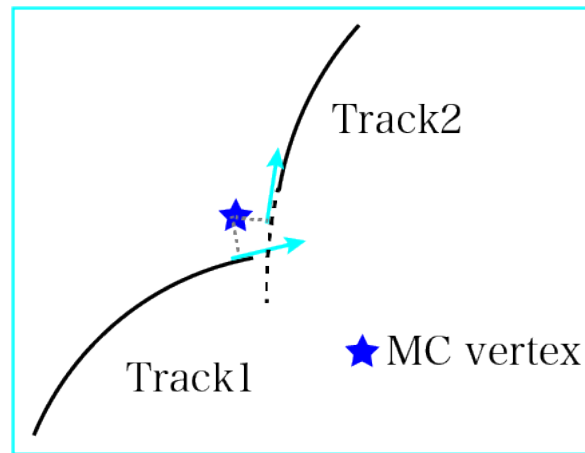

$\delta m_{\text{kink}} (\tau^- \rightarrow \mu^- \bar{\nu})$

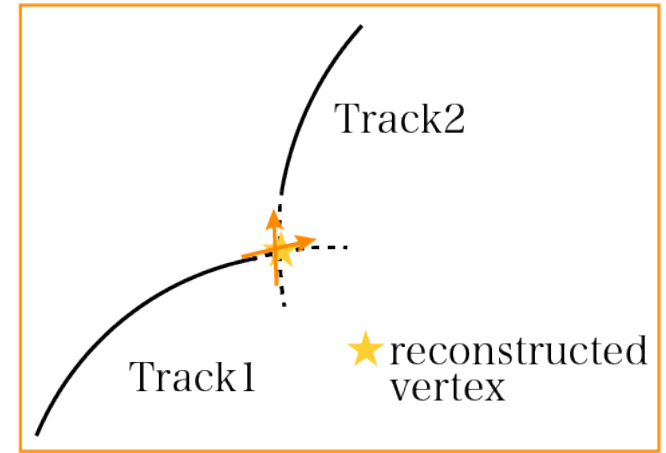

$\delta m_{\text{kink}} (E^- \rightarrow \pi^- \lambda)$

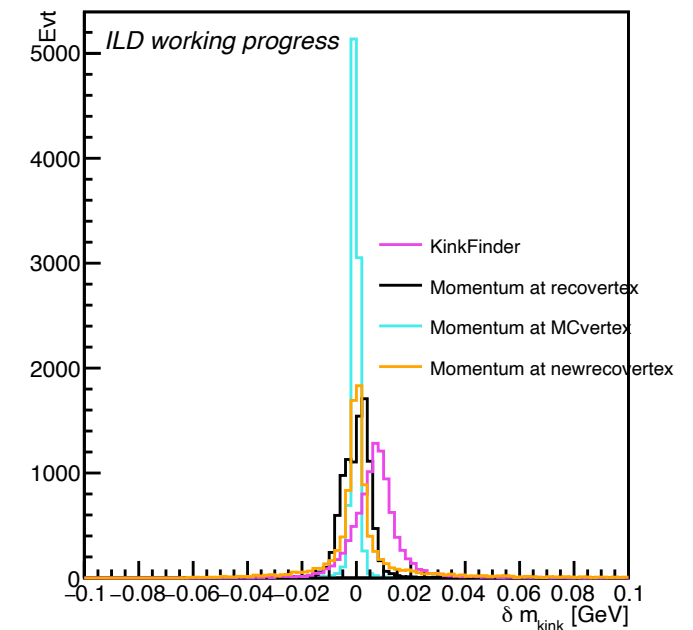
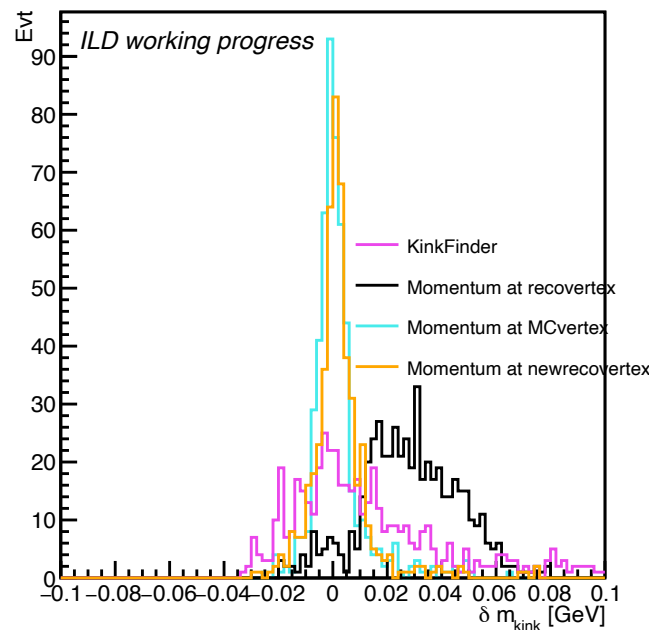
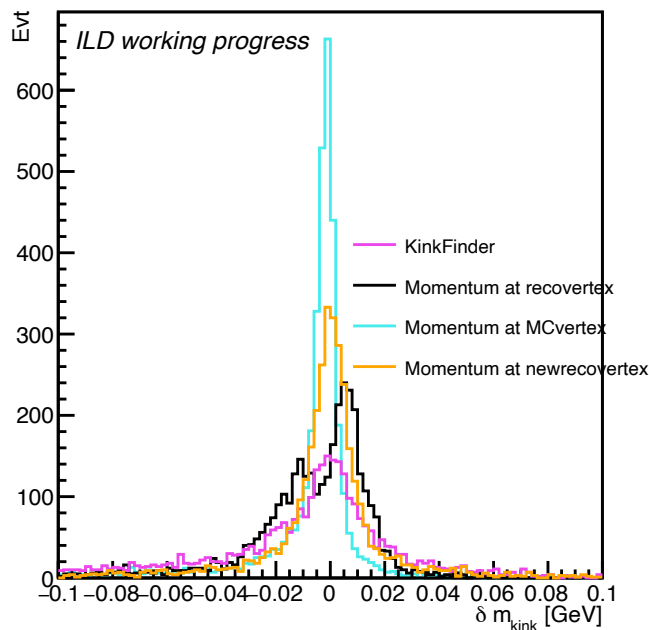

Improving mass resolution!

Summary

Kink is useful for LLP search!

KinkFinder efficiency is about 80% ($0.04 < \theta_{\text{kink(MC)}} < 0.08$)

Improving mass resolution

<- better vertex position

<- better track momentum at vertex

Next steps

- Improving efficiency at small and large kink angle
- Kinematic vertex fitting
- SM kinks with other momenta
- Interpret results with BSM models

New likelihood function - try1

KinkFinder

$$\text{likelihood } K \equiv 3.125 \times \delta K \times \delta K + tK \quad \delta K \equiv \frac{|m_{kink} - m_K|}{\text{K mass resolution (0.075 [GeV])}}$$

$$L_K \equiv \frac{1}{\sqrt{2\pi\sigma}} e^{-\frac{1}{2} \left(\frac{\delta m_K}{\sigma} \right)^2} \times e^{-tK}$$

Ignoring

$$\delta m_K \equiv m_{\text{reco}K} - m_{\text{true}K}$$

I find σ from $\delta K'$, $\delta \pi'$, $\delta \Sigma'$ and $\delta \Xi'$ distribution.
I used "RMS90".

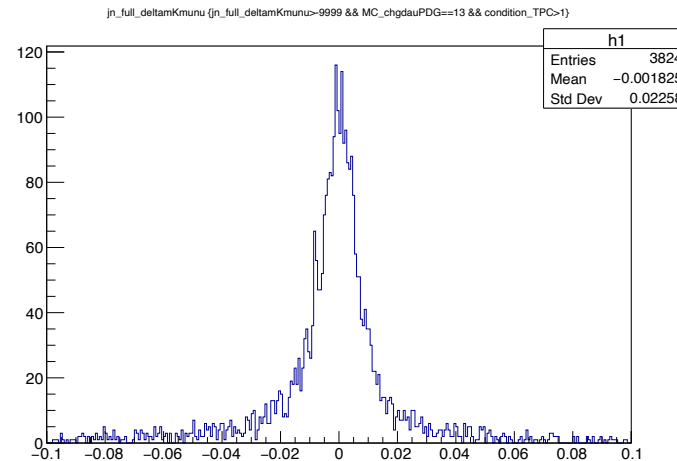

Distribution of new likelihood function

Likelihood($K \rightarrow \mu\nu$)

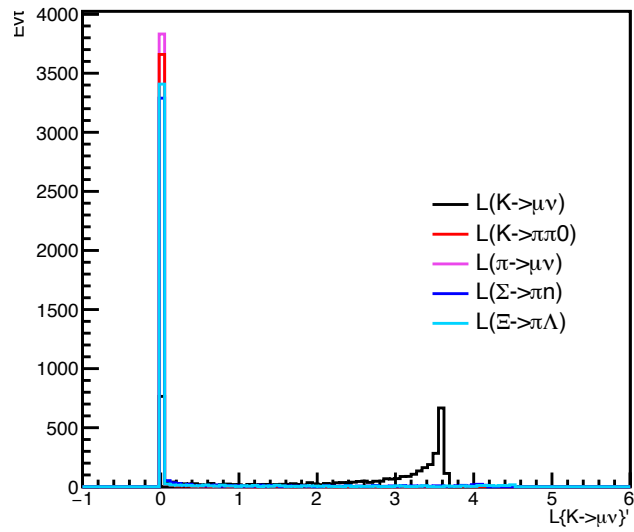

Likelihood($K \rightarrow \pi\pi 0$)

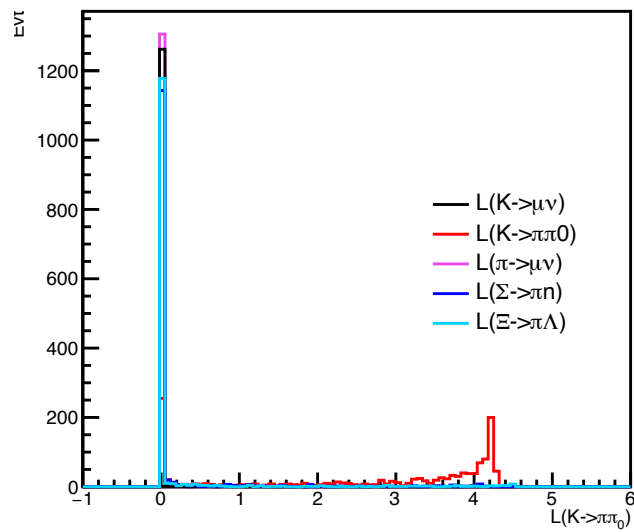

Likelihood($\pi \rightarrow \mu\nu$)

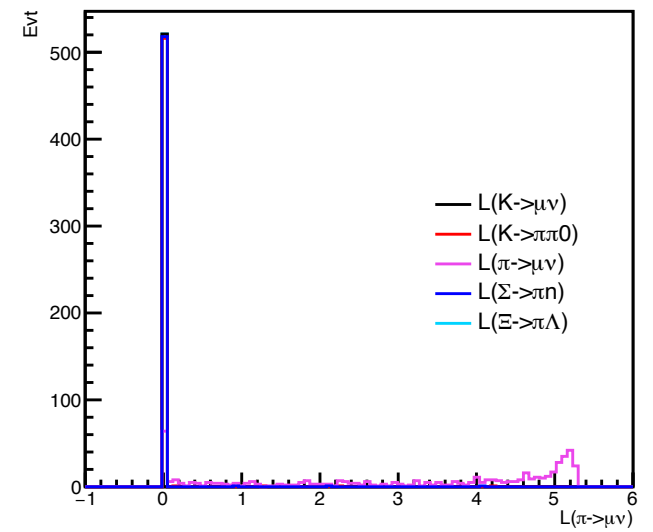

Likelihood($\Sigma \rightarrow \pi\eta$)

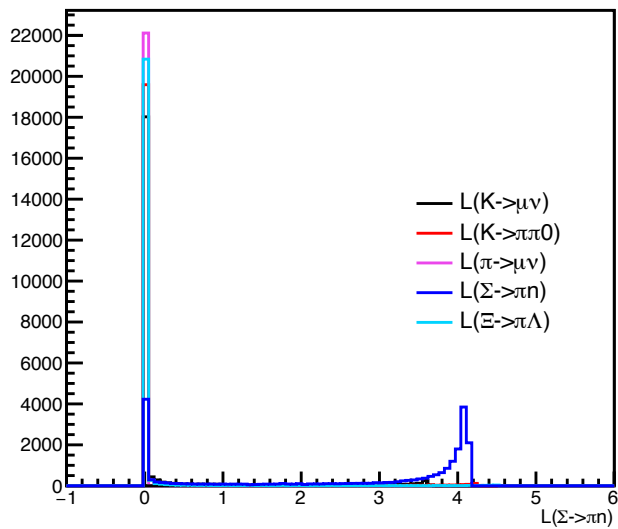

Likelihood($\Xi \rightarrow \pi\Lambda$)

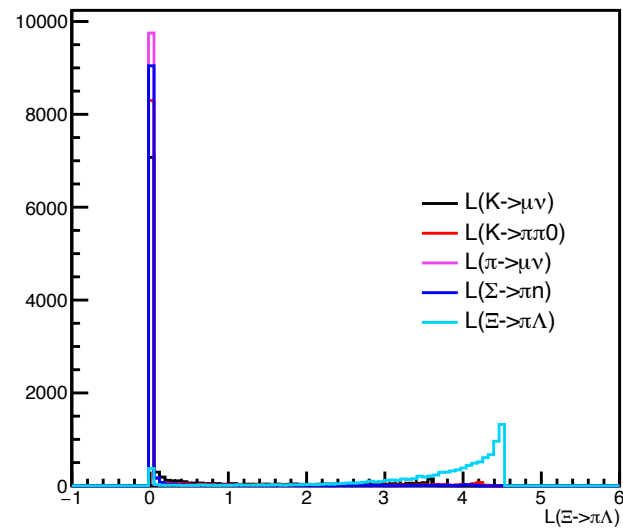

Kink angle on each pdgs - KinkFinder

Prerequisites made from MCparticles

- Endpoint(MC) inside TPC: $329 + 100 < r < 1770 - 100$ [mm] $|z_{max}| < 2350 - 250$ [mm]
 - (MC) # of charged daughter of Kaon = 1
- Each pdg plots are imposed Marlintrk = 2 and reconstructed kink exists

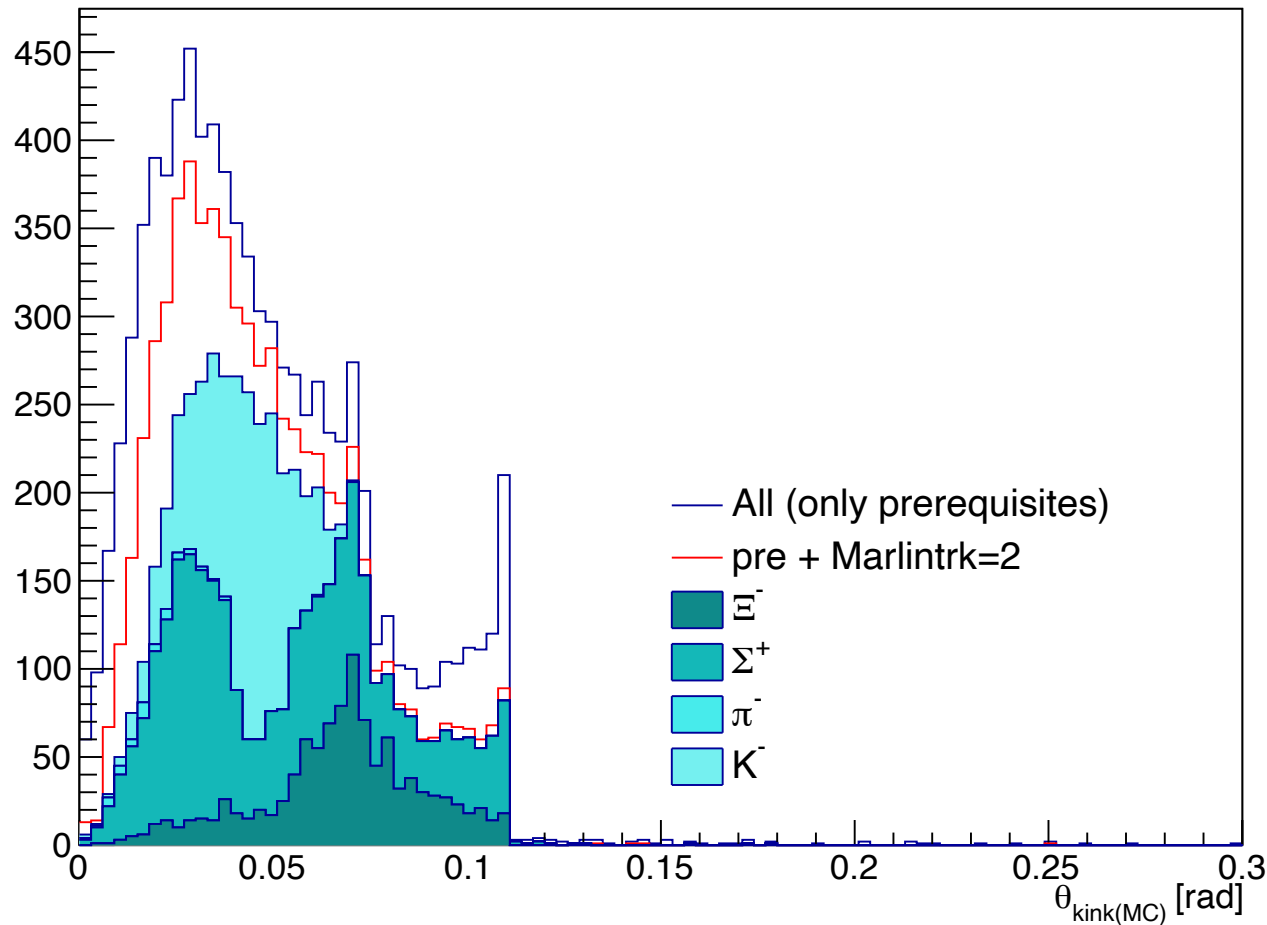

In Kaon samples, many kinks are misidentified

KinkFinder vs New - δm distribution (Kaon)

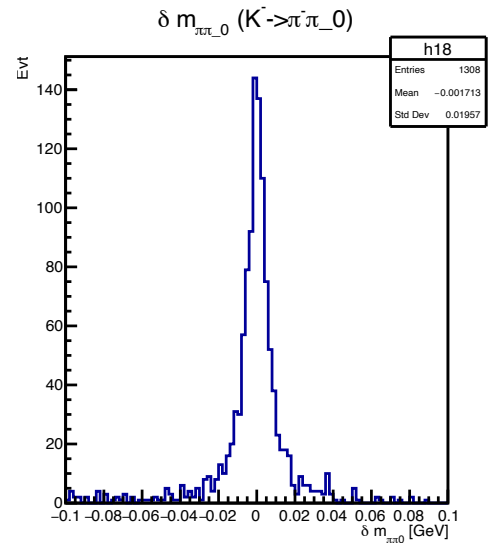
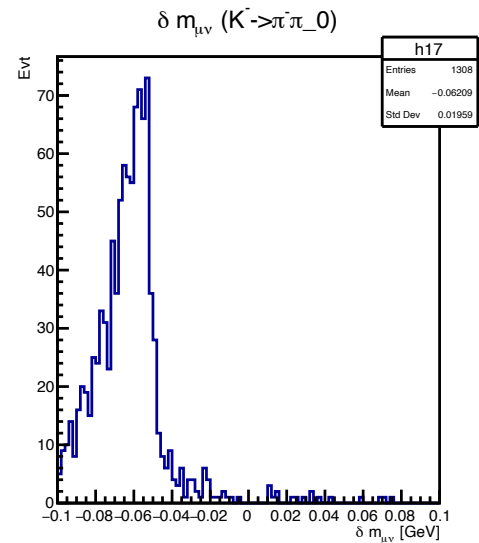
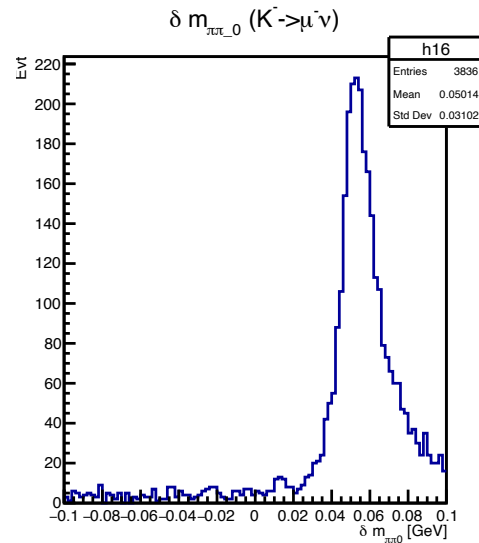
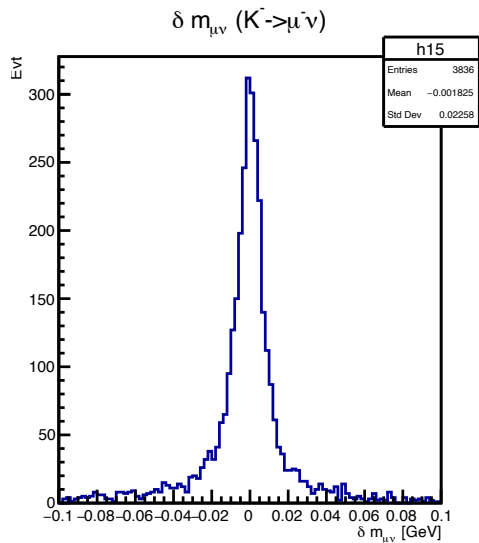
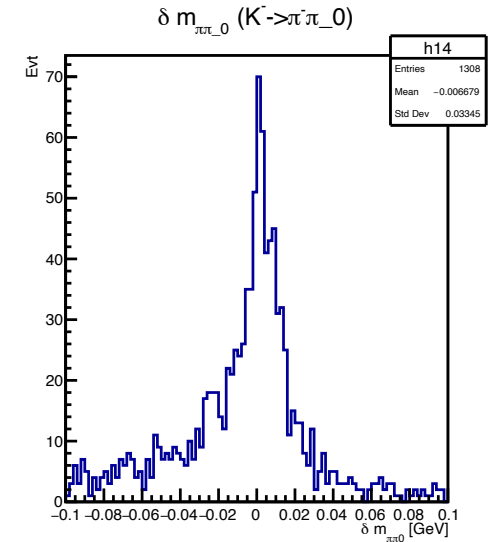
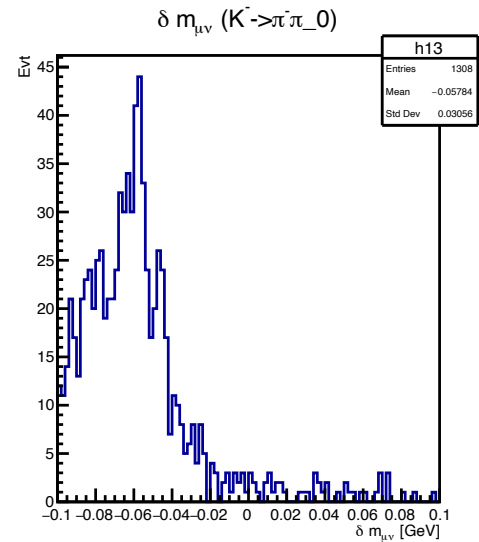
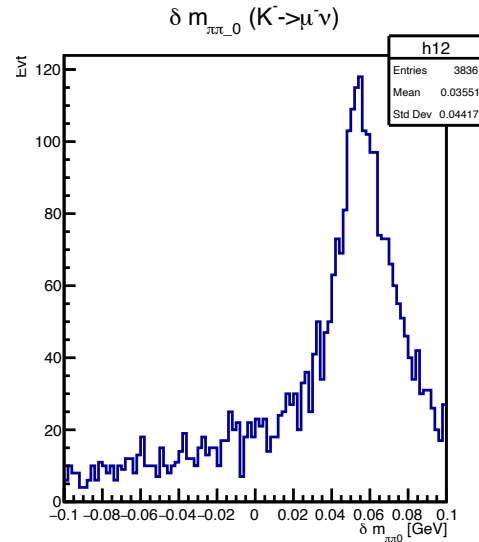
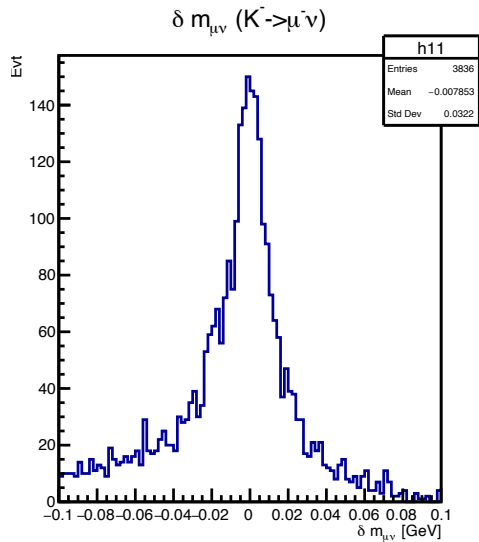

Table: sigma by RMS 90 - New

	Sigma	Error of sigma
K->munu	0.012136338	0.00015802845
K->pipi0	0.0088005273	0.00019342986
Pi->munu	0.0057965286	0.00019430008
Si->pin	0.0093852586	4.3146168E-05
Xi->pilamda	0.0078814737	3.9757787E-05