



# Where YOU can contribute in SiD.

*H.Weerts*

*Argonne National Lab*

*for SiD concept design study*



# SiD on Sunday

H.Weerts

Welcome and thanks for staying an extra day to attend this SiD meeting

- 0900 How to Get Involved. Harry Weerts
- 0920 SiD R&D Highlights and R&D Plan Andy White
- 0950 What Performance must an ILC Detector Have? Tim Barklow
- 1020 SiD PFA: Status and Plans Lei Xia
- 1040 SiD Tracking Simulation: Status and Plans Rich Partridge
- 1100 Coffee Break
- 1115 SiD's Homework for the Detector Concept Report John Jaros
- 1135 Document System for SiD Tom Markiewicz
- 1155 Questions, Answers, and Open Discussion All
- 1300 Conclude



## The assumptions behind SiD

H.Weerts

- Particle Flow Algorithm will deliver best performance, use as base
- Si/W is right technology for EMCAL
- Limit tracking radius/EMCAL to limit costs
- Increase B field to maintain  $BR^2$
- Use Si tracking only, for best  $\delta p/p$  and low mass
- Use pixel vertex detector for best pattern recognition
- Emphasize integrated, hermetic detector design

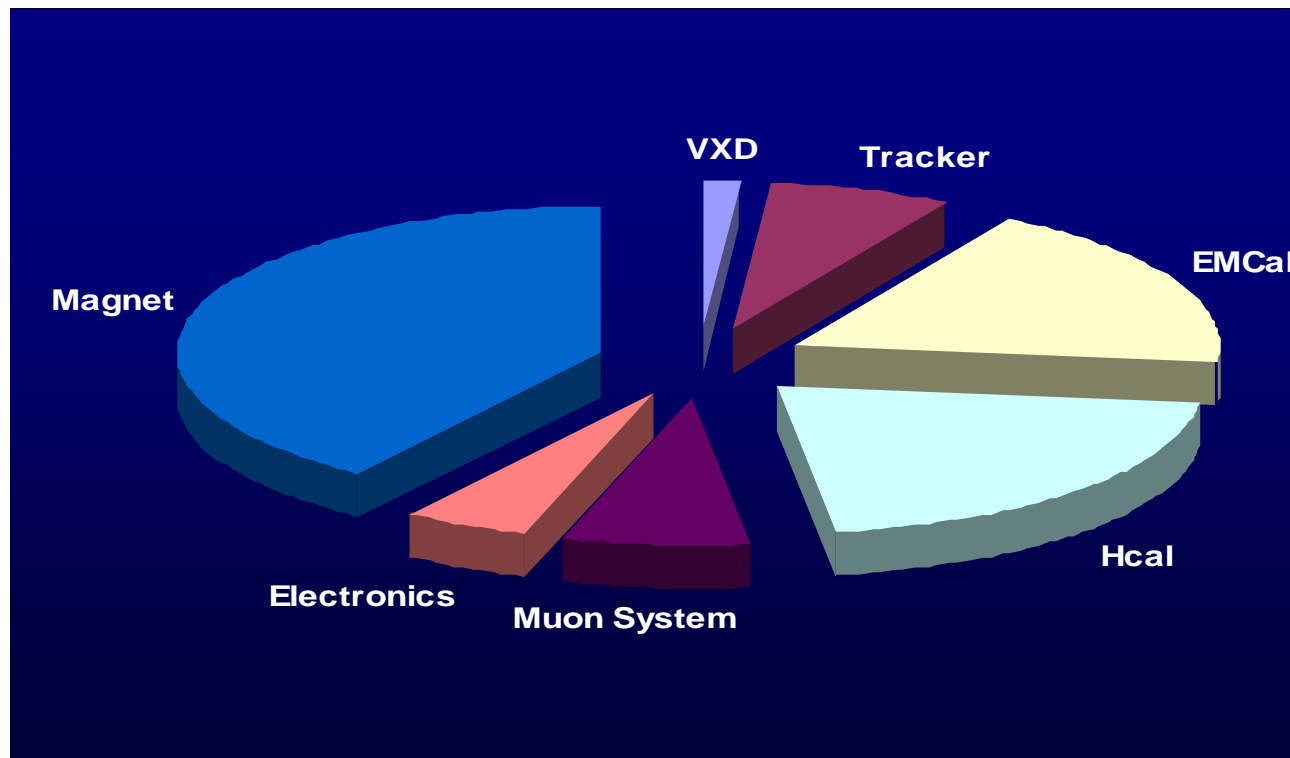

Constrain/keep track of costs as part of an optimal design



## SiD: salient features

H.Weerts

- Smallest  $L^*$ , compatible with crossing-angle reach
- VXD: smallest radius ( 5T helps)
- Tracker: excellent  $\delta p/p$ ; silicon robust; minimize material uniformly over  $\cos(\theta)$ ; demonstrated pattern recog ( in  $\rightarrow$  out; out  $\rightarrow$  in, stand alone)
- ECAL: excellent segmentation 4x4 mm,  $R_{\text{Moliere}}=13\text{mm}$
- HCAL: excellent segmentation; few centimeters square
- Calorimetry: imaging, hermetic
- Solenoid: feasible, 5T
- Instrumented flux return & imaging HCAL: excellent muon ID
- Time stamp/digitize bunch by bunch
- Cost: constrain cost, have a parametric model

Flux return/muon Fe: 48 layers,  
 $R_{in} = 333 \text{ cm}$  &  $R_{out} = 645 \text{ cm}$

Solenoid: 5 T;  $R_{in} = 250 \text{ cm}$

HCAL Fe: 34 layers;  $R_{in} = 138 \text{ cm}$

EMCAL Si/W: 30 layers;  $R_{in} = 125 \text{ cm}$

Si tracking: 5 layers;  $R_{in} = 18 \text{ cm}$

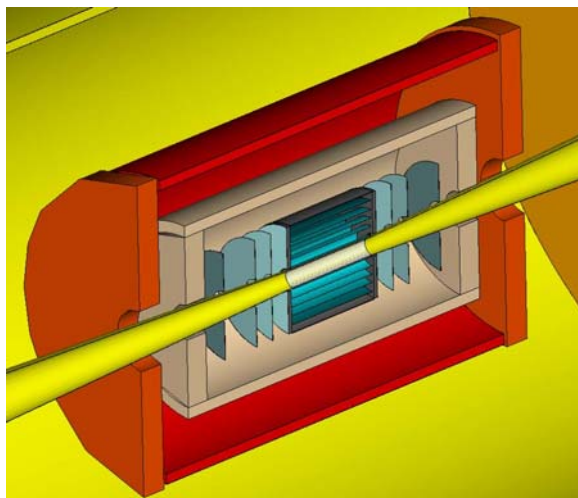
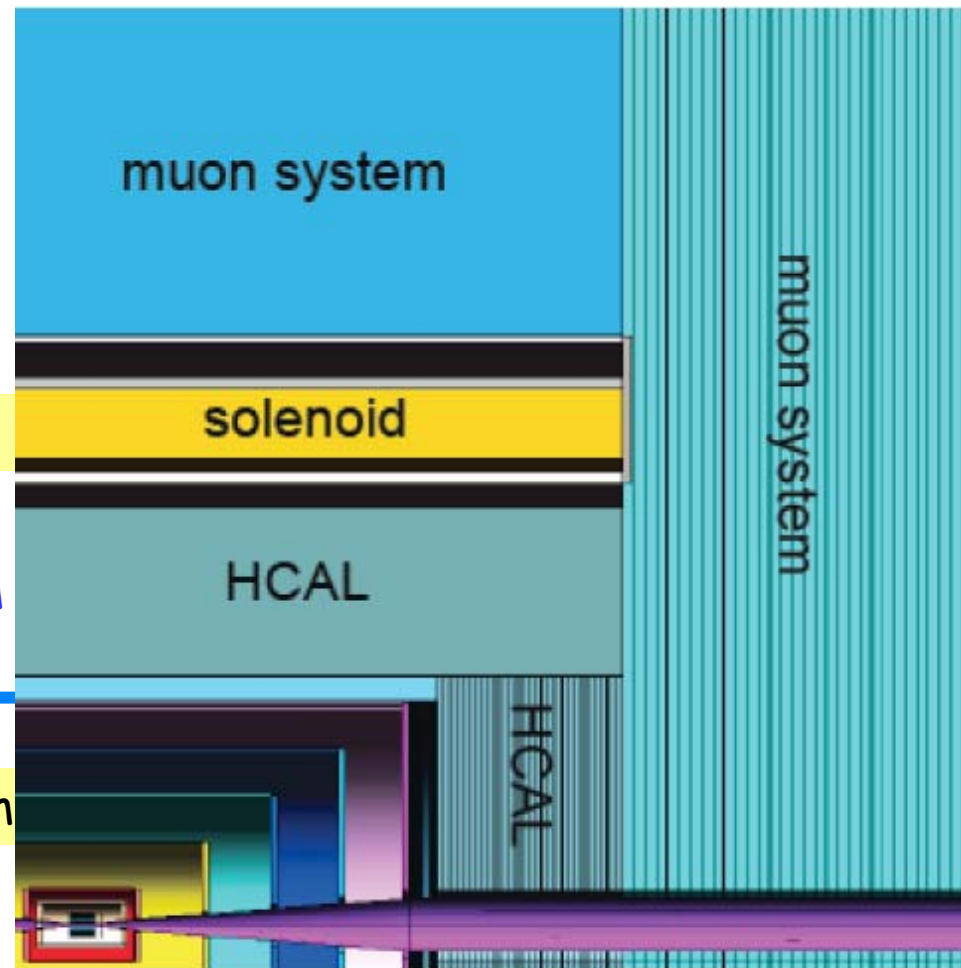

Vertex detector: 5 barrels, 4 disks;  $R_{in} = 1.4 \text{ cm}$

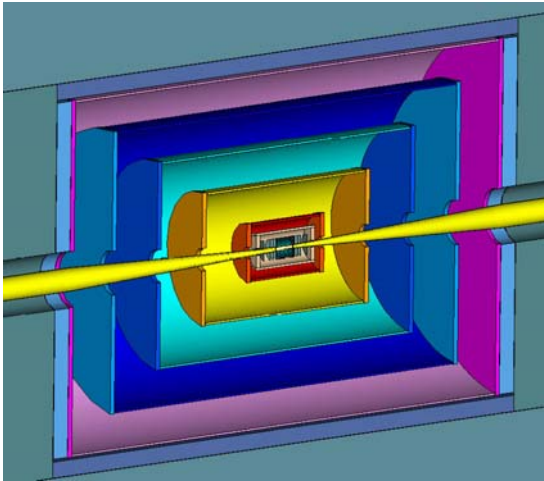

Vertex + tracking: integrated mechanical design

Vertex detector: integral part of tracking system; seed for tracks.

Silicon strip based tracking system: currently 5 layers.

Forward region needs work and attention

Optimization of #layers, outer radius of tracking → optimization studies

Axial only or Axial/Stereo

Thickness—impact on PFA

$K^0$ 's- how good do we have to do; out-in-tracking

Reconstruction czar

More...

From Rich Partridge



# Calorimetry

H.Weerts

## EMCAL

Hardware and performance pretty clear. Group working towards mechanical design, electronics, simulation.  
Forward region ?

## HCAL

Is inside solenoid, about  $4\lambda$  thick.

Need to optimize design: default is RPC's for now but other technologies (GEM, scintillator) are considered.

Prototyping

Need a large scale beam test to prove feasibility

Detailed understanding of GEANT simulations necessary for absorber choices ( Fe, W ) & detector choices

Coordination Andy White

EMCAL

R.Frey & D.Strom

HCAL

G.Blazey & H.Weerts



# Solenoid

Participate in feasibility study.  
Already involved: Fermilab, KEK and Toshiba

R&D program on conductor

5 Tesla field in short solenoid is not easy.

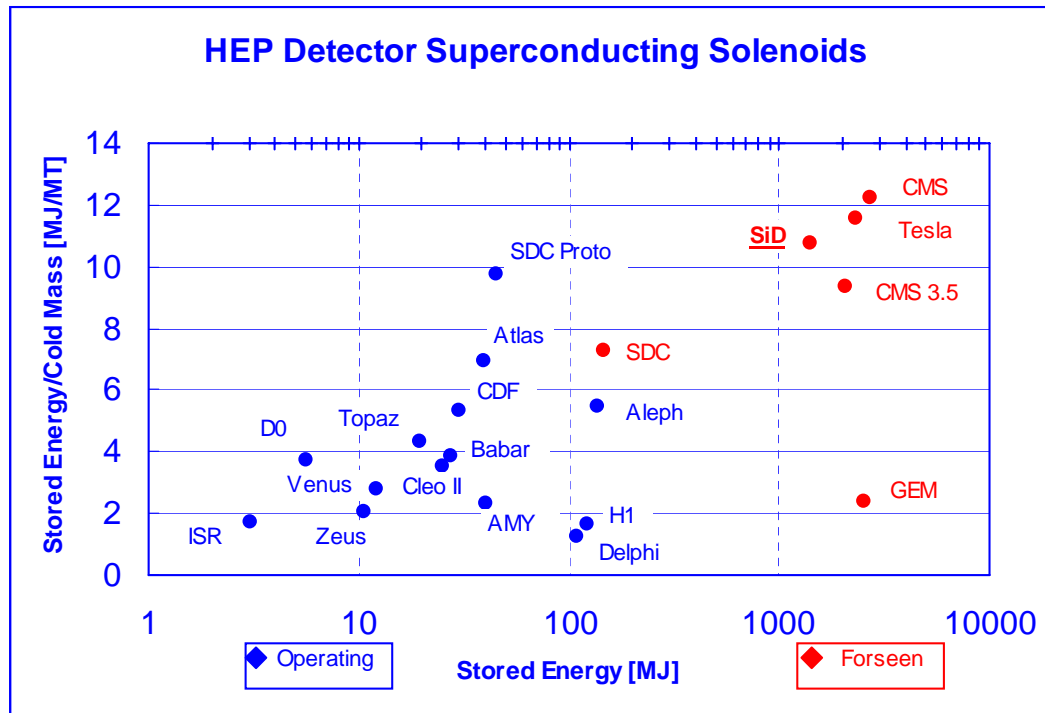

Need to identify coordinator



Even though we want best performance for each sub detector, the overriding physics performance is dictated by how well we measure jets i.e the Particle Flow Algorithm.

It needs all detectors to perform at certain ( not yet fully explored) levels. For example: imaging calorimeters, but inherent energy resolution of HCAL may not be a dominating factor.

PFA algorithms have improved in last year and we now have results, but more work needed before we can feel confident that they can be used for detector optimization.

GOAL: Use existing PFA's for optimization.....

More by Lei Xia & already at VLCW06

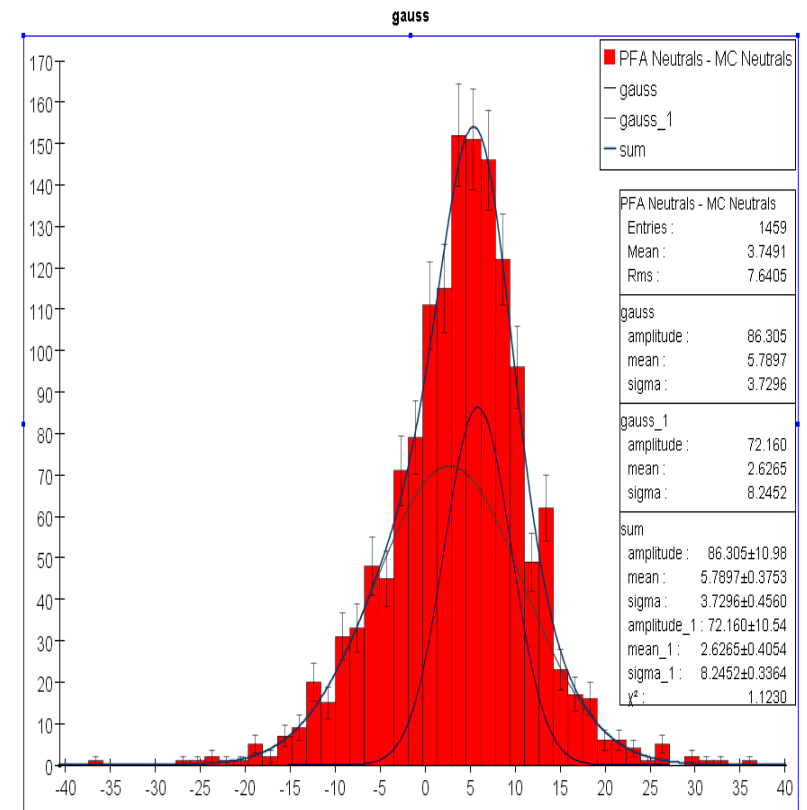

Instrument flux return iron

How much muon ID is needed after fine segmented calorimeters i.e. physics requirements?

Which technology for chambers?

Same as HCAL ?

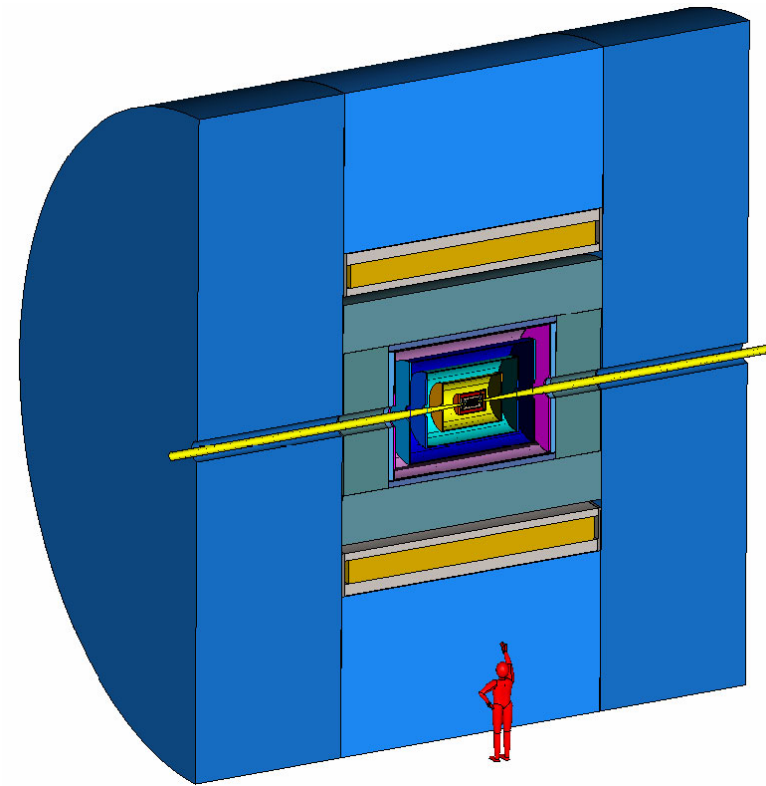



## Forward region

H.Weerts

Forward region has not been optimized yet and needs work.

Work started by Brookhaven.



## Very far forward region

H.Weerts

Interaction with MDI group

Luminosity determination

Very far forward EMCAL, tag

Polarization and energy measurements (LEP group does not exist)  
in SiD



## Simulation available

H.Weerts

Have a framework for simulation

SID<sub>00</sub> has been simulated and files are available. Used for Snowmass.

Based on simple cylindrical shapes, but we feel this is sufficient to explore different geometries at this time.

Critical for optimization of design

Also detailed studies of calorimeter response for different particle types and different detectors. Needed for HCAL optimization.

Need manpower to use what already exist & build on it



# Analysis & Benchmarking

H.Weerts

Benchmarking is on going --- can use help

Analysis help is needed here for optimization

Physics requirements have to be revisited

Especially the required jet energy resolution  
( see talk by T.Barklow)



# Optimization

H.Weerts

Performance evaluation of baseline SID 00 has started and even some exploration of varying parameters.

This needs more work in developing more algorithms and determining physics performance as function of detector parameters:

- Solenoid field strength ( $< 5T$ )

- Tracking radius

- HCAL thickness

- .....



# Overview of SiD: organization

H.Weerts

Put SiD organization in place in Fall & Winter '04/'05; form subgroups. This gives you an idea who to contact.

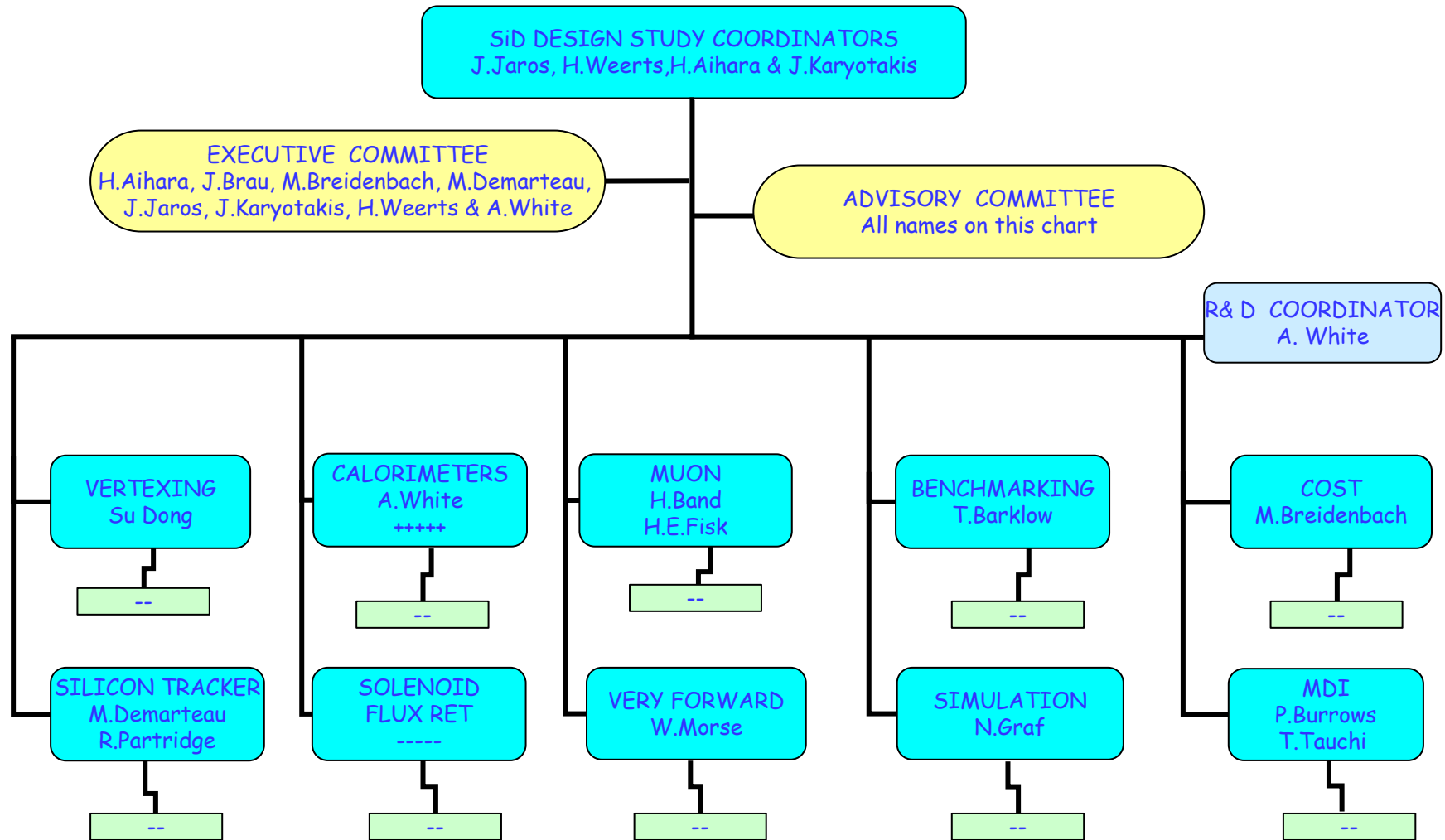





## Conclusions

H.Weerts

A lot to do in SiD to move design forward

Basic ideas and biases which guide us are in place

Optimization not done yet

Many directions are by no means final

There is definitely a lot of overlap with other concepts

WEB site: <http://www-sid.slac.stanford.edu>



The END



# Detector outline

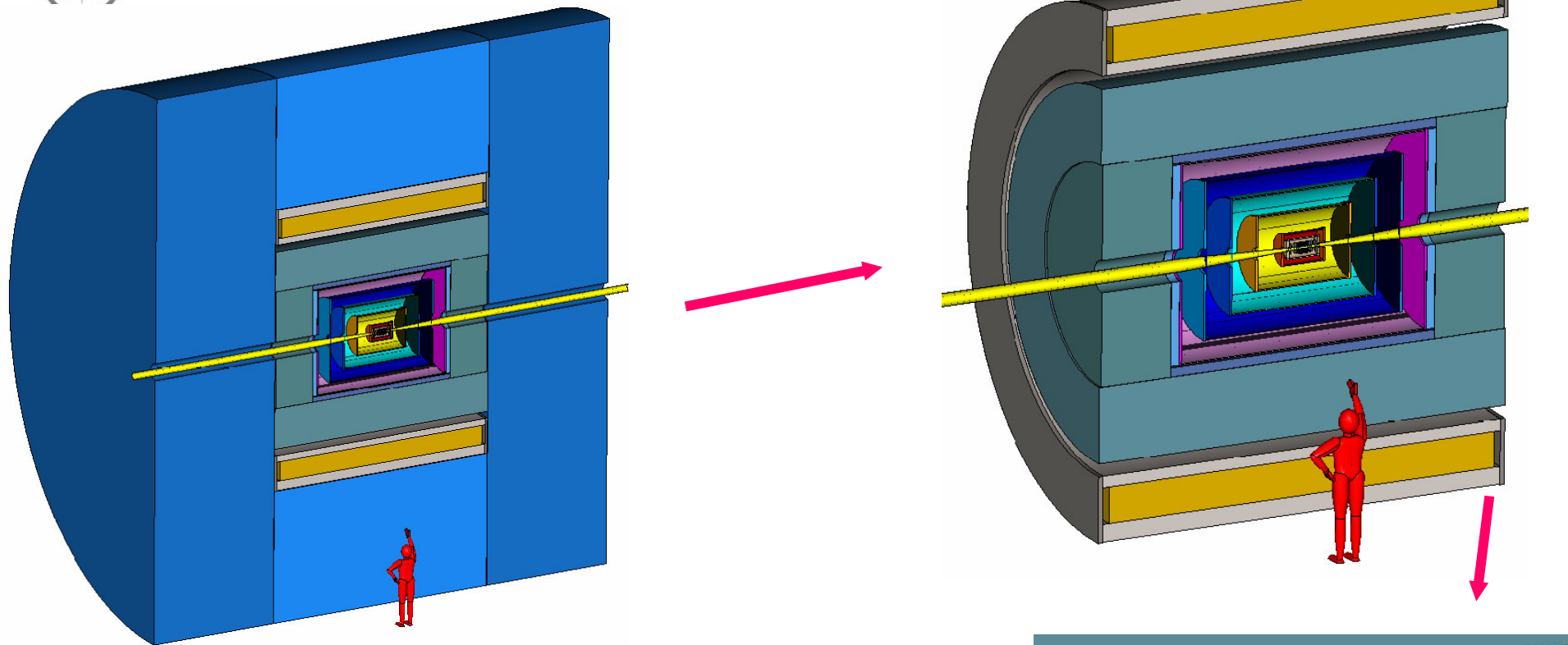

A high performance detector for the LC  
Uncompromised performance  
BUT Constrained & Rational cost

This is  
simulated SiD<sub>00</sub>

