

Nikhef Pixel TPC particle identification performance

Yevgen Bilevych, Klaus Desch,
Sander van Doesburg, Harry van
der Graaf, Fred Hartjes, Jochen
Kaminski, Peter Kluit, Naomi van
der Kolk,
Cornelis Ligtenberg,
Gerhard Raven, and
Jan Timmermans

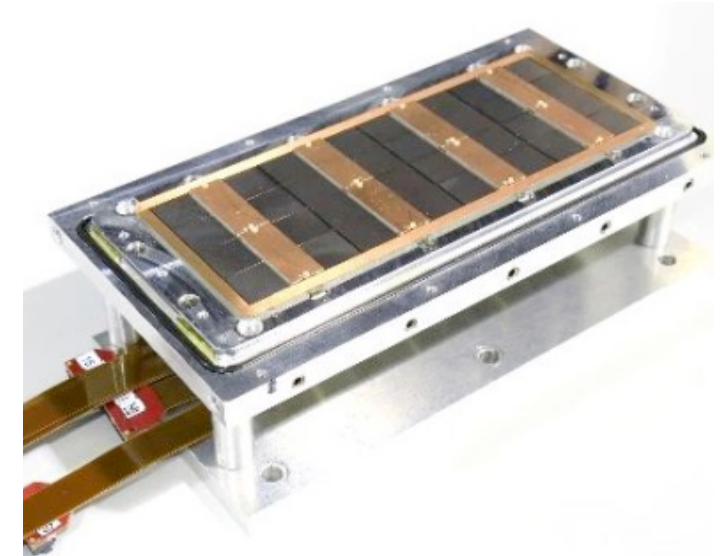

LCTPC Bonn January 2025

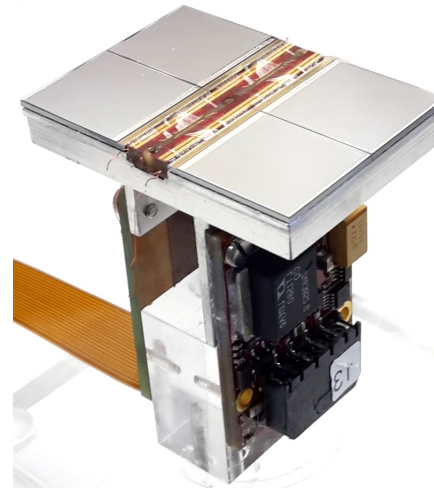

LCTPC Bonn meeting January 2025



Peter Kluit (Nikhef)



Discuss of two NIM papers on module performance

- First paper with emphasis on module construction and tracking performance (some items this talk)

Towards a Pixel TPC part I: construction and test of a 32-chip GridPix detector

- Second paper with emphasis particle identification (this talk)

Towards a Pixel TPC part II: particle identification with a 32-chip GridPix detector

Number of hits per chip

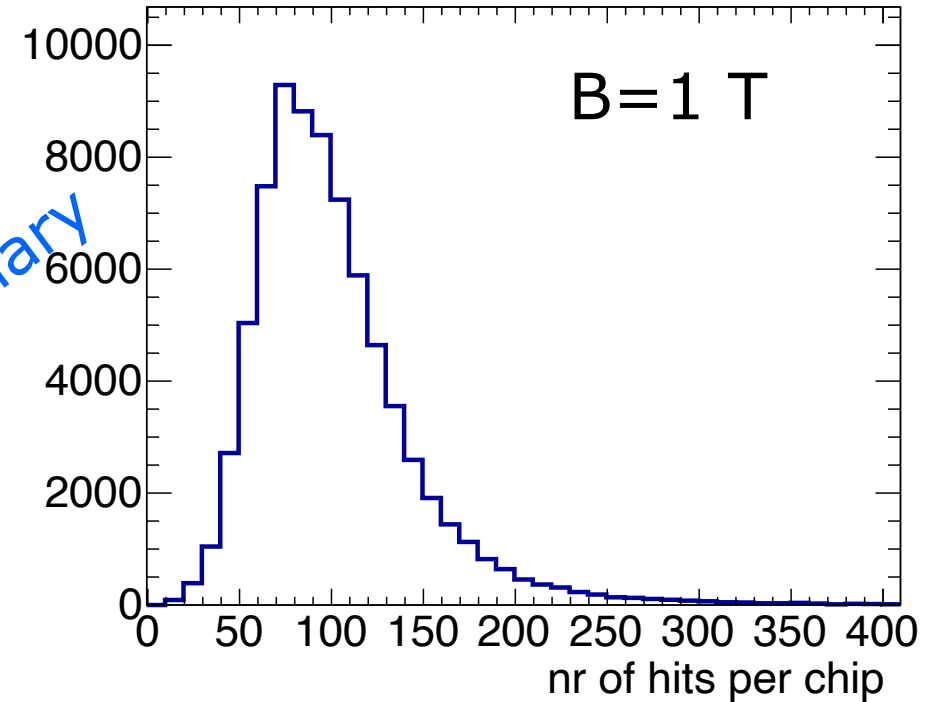
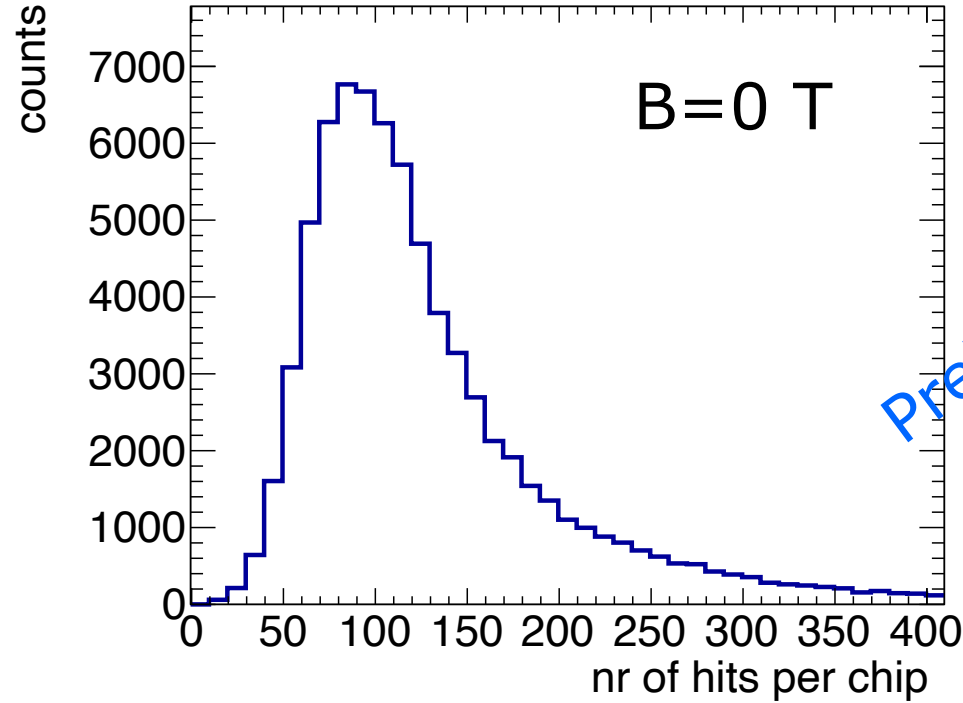

Preliminary

- B=0 T has a large Landau tail
- B=1 T smaller Landau tail and a more gaussian distribution
- An electron crossing 8 chips in the module has about 1000 TX3 hits

Single-electron efficiency of the module

- The single electron efficiency for the quad detector as a function of the grid voltage and the measured ToT
For the module $\langle \text{ToT} \rangle = 0.68(0.86) \mu\text{s}$ at $B = 0(1) \text{ T}$
- The following results were obtained

	$\langle \text{hits} \rangle$ (MOP) B=0	$\langle \text{hits} \rangle$ (MOP) B= 1
Measured	124 (87)	89 (64)
MagBoltz	106	-

Values measured with TPX3 chip at $V_{th} = 550 \text{ e-}$
Efficiency curve measured in Ar/C4H10 82/18
Gain curve measured with test pulses (Kees Ligtenberg)
8-5-2021

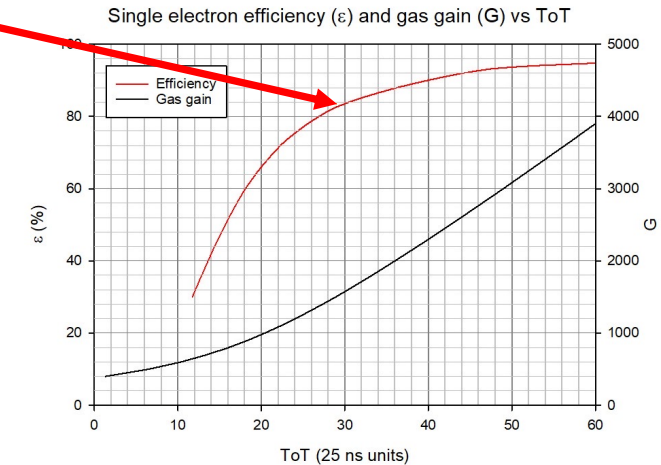

This is consistent with a detector running at 85% single-electron efficiency

Particle Identification (PID) performance

- The number of hits per unit of track length can be used to identify particles by hit or cluster counting
- Here not only the number of hits or clusters are important but also the fluctuations
- Comparing the number of hits for B=1 T to 0 T one can observe a reduction of the fluctuation
- For a GridPix we know that there is a contribution from UV photons that contribute to the Landau
- The HV scan shows extra hits that are produced

Note the smaller the fluctuations* the better the PID

* So if one can reduce the UV photons, using e.g. a double grid it will improve further the PID performance

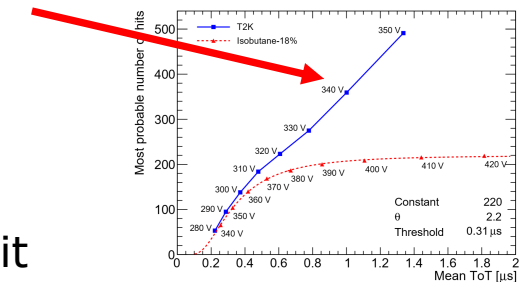

- Combine chips to form 1 m long track with 60 % coverage for electrons
- **Truncation method:** reject large clusters and then run dEdx @ 90% with slices of 20 pixels along track (xy) (gives nr of selected hits). A large cluster has more than 6 hits in 5 consecutive pixels.
- **Template fit method:** fit the slope of the N_{scaled} minimum distance in xy (d) distribution with an exponential function ($N_{\text{scale}}(d)$ =defines the inverse weights):

$$N(d)_{\text{scaled}} = N_{\text{scale}}(d) N_{\text{observed}}(d)$$

$$N(d)_{\text{scaled}} \text{ is then fitted for each track with } N_0 \exp(-\text{slope } d)$$
- Calculate the "PID" variable for electrons and MIP (==70% of hits)
 - Truncation method = nr of selected hits
 - Template fit method = slope
 - Resolution is $\sigma = \sigma(\text{PID})/\text{PID}$ (for σ we use the rms)

Calculate minimum distance in xy between the hits.

The slope of the distribution is related to the number of primary clusters/cm.

The diffused peak at $d < 10$ pixels comes from clusters with > 1 hit.

Single chip

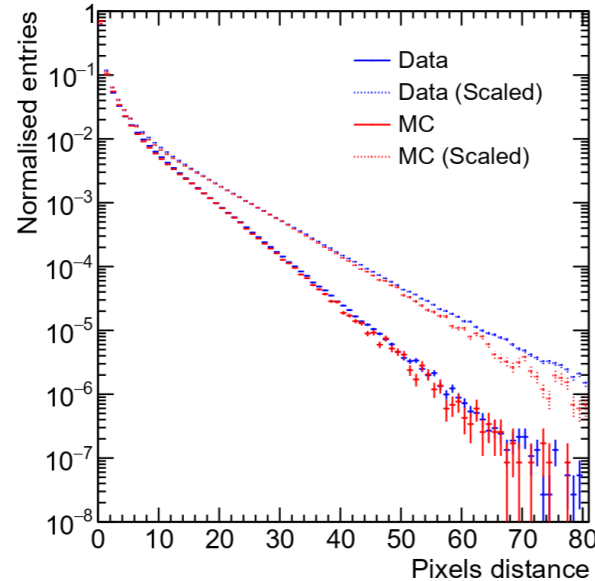

Quad module

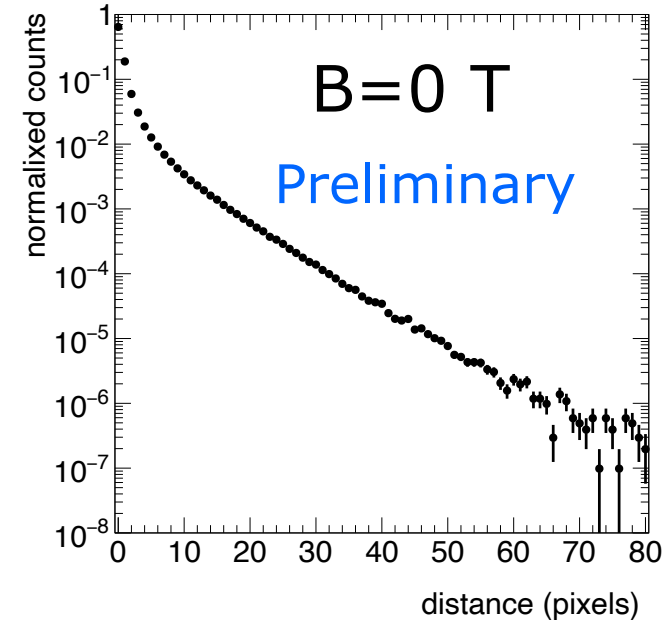

Figure 5.19: Distribution of distance between hits for a 2.5 GeV electron in pixels from test beam data (blue) and from a Monte Carlo simulation (red).

Thesis Kees Ligtenberg

Peter Kluit (Nikhef)

Performance of dEdx

Template fit of slope of the distance distribution

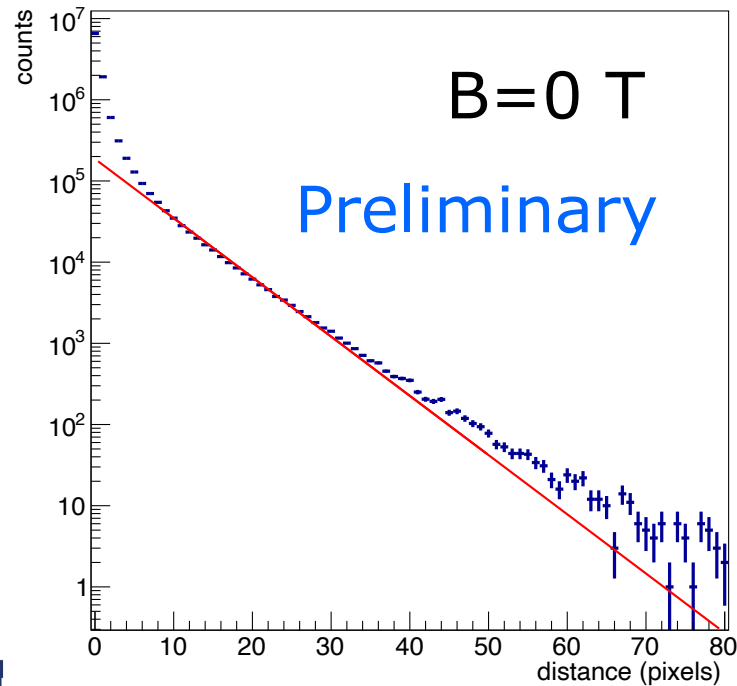

From 10 clusters onwards an exponential distribution is followed.

Below 10 the distribution will be down-weighted ($N_{\text{scale}}(d) = 1/\text{weight}$). The weights are:

Weights B=0 = { 35.0467 , 12.1497 , 4.52914 , 2.76311 , 1.99386 , 1.59795 , 1.3656 , 1.21409 , 1.11898 , 1.04385 };

Weights B=1 = { 22.5617 , 7.39573 , 2.43318 , 1.54528 , 1.23428 , 1.09727 , 1.04368 , 1.01625 , 1.00182 , 0.998178 };

Note the difference in weights in the B=0 and 1 T data sets. This is related to the large Landau fluctuations

PID performance truncation method

Electron resolution
3.6%
1 m track 60% and
coverage
Linearity MIP-e = 1.03
z drift=5-15 mm (flat)

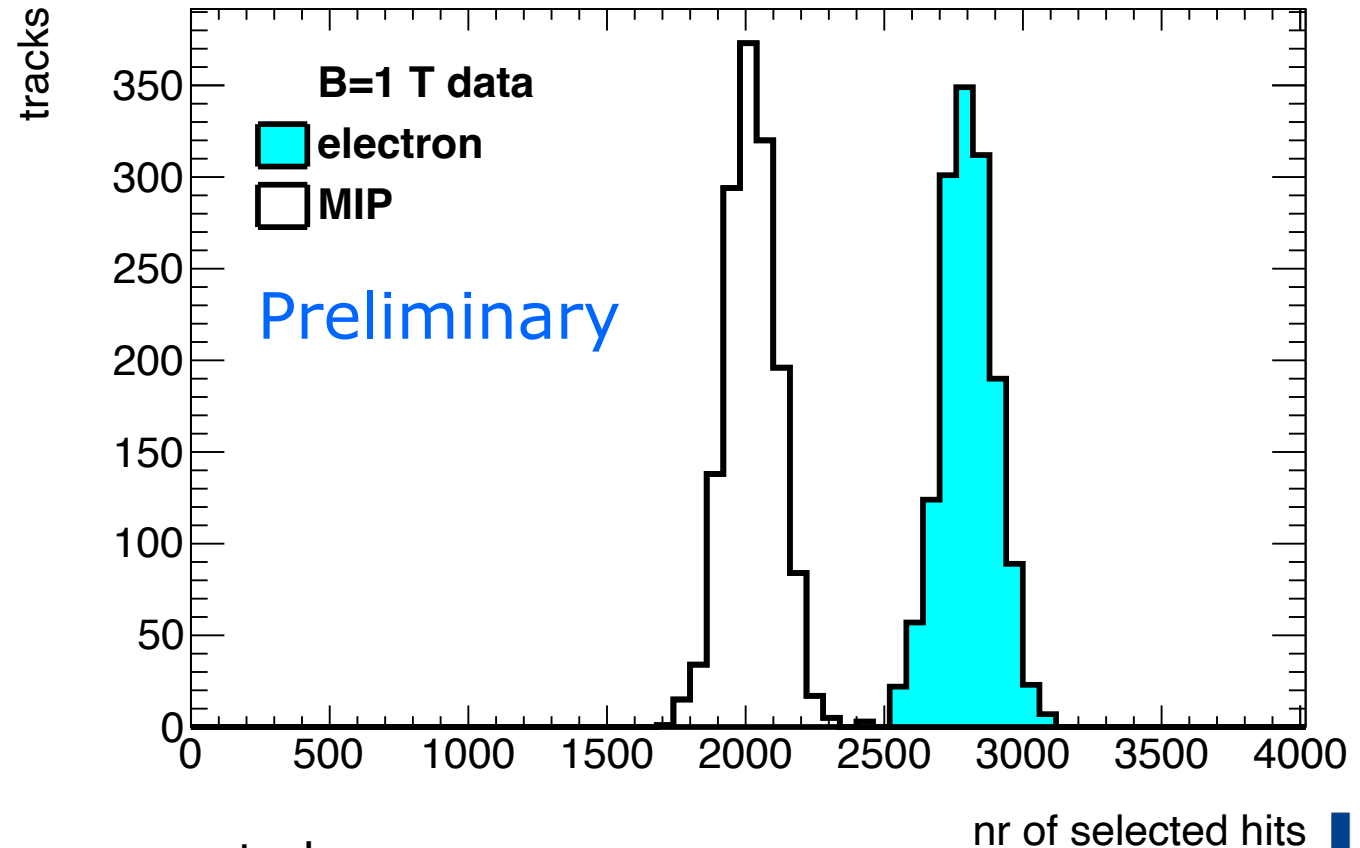

MIP in plot was corrected ...
thanks Ulli

Peter Kluit (Nikhef)

PID performance template fit method

Electron resolution
 2.9%
 1 m track 60% and
 coverage
 Linearity MIP-e = 1.07

 so syst uncertainty on
 resolution +7%

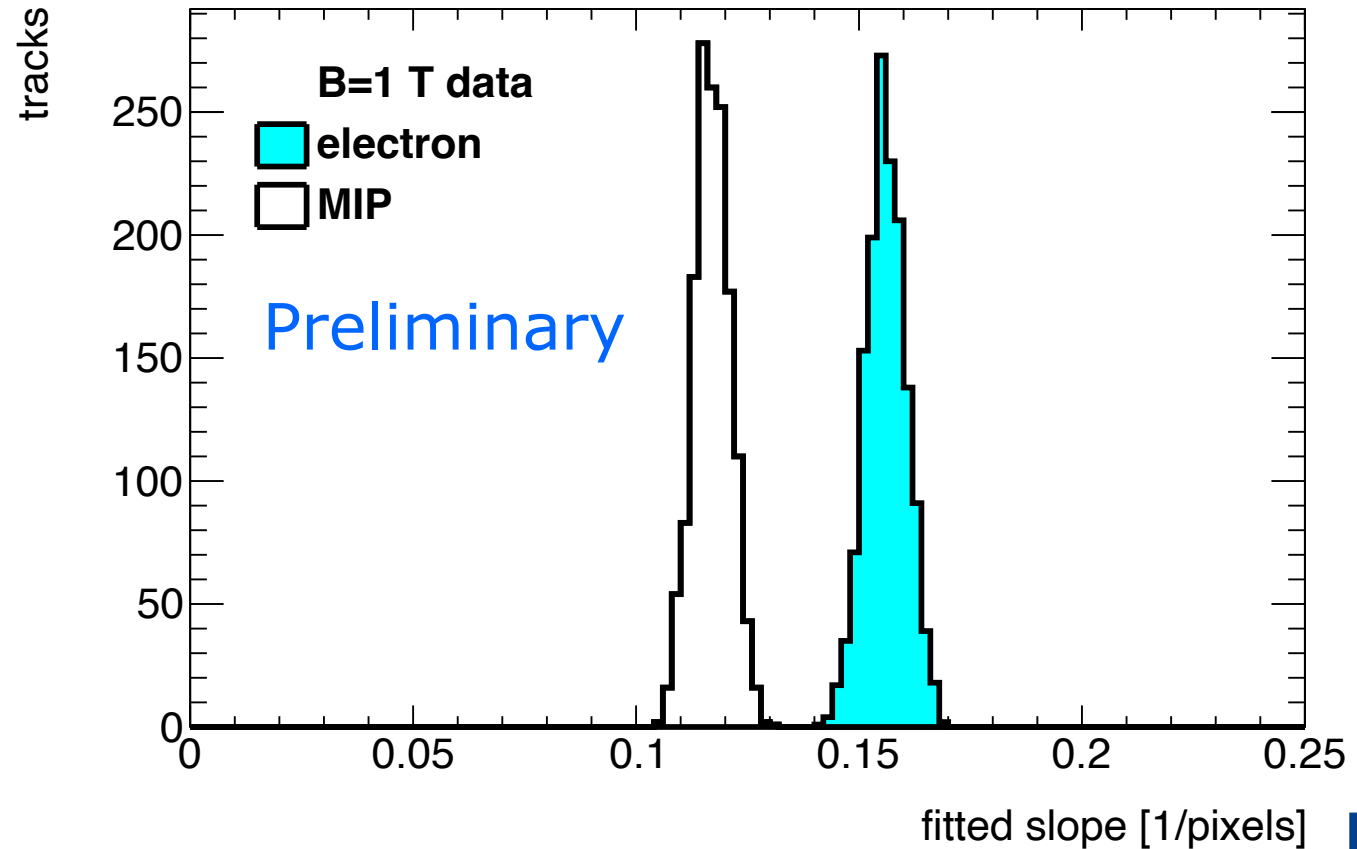

PID performance of a Pixel TPC

The dEdx resolution for electrons from data by combining tracks to form a 1 m long track with realistic coverage $\sim 60\%$ coverage.

Preliminary

Method	B=0 Resolution (%)	B= 1 T Resolution (%)
Truncation	6.0	3.6
Template fit	5.4	2.9

The truncation method has a slightly worse performance – as it is more sensitive to the hits than the template fit method – that is more sensitive to the number of clusters.

PID Performance extrapolated to the ILD detector

Test beam $B = 1 \text{ T}$
 $p = 5,6 \text{ GeV}/c$

Template fit (Truncation)
electron resolution
 $2.9 (3.6)\%$

1 m track 60% and
coverage

ILD detector

$r_{\text{Inner}} = 329 \text{ mm}$ $r_{\text{Outer}} = 1770 \text{ mm}$

electron resolution = $2.4 (3.0)\%$
at $\theta = \pi/2$

Assume Pixel TPC performance at
 $B = 1 \text{ T}$ at $p = 5,6 \text{ GeV}/c$

ILD dEdx performance

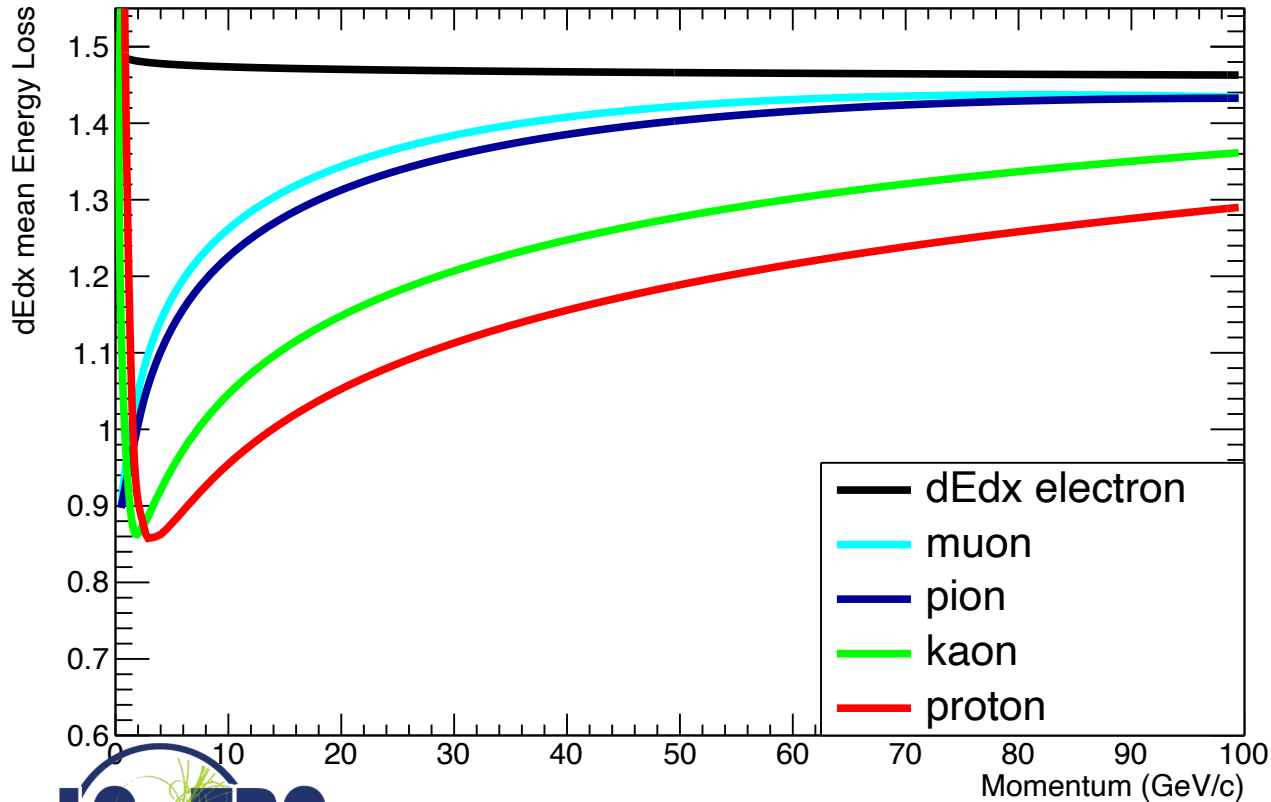

- From dEdx studies in ILD (Ullrich Einhaus)
- Extracted the ILC soft parametrisations for energy loss based on G4 and full simulation of the ILC TPC with T2K gas
- [Link](#) generated in 2020 with ILC soft v02-02 and v02-02-01

ILD Pixel TPC PID performance

- ILD PID performance is evaluated using the ILD dEdx parametrisation
- For an ILD detector with
 - rInner = 329 mm
 - rOuter = 1770 mm
 - zMax = 2350 mm // half length
- The truncation and template fit method results at B = 1T for the electrons are used as resp. worse and best scenarios
- The performance plots assume $\cos \theta = 0$ and the PID resolution scales as:

$$1/\sqrt{\text{track length} \cdot \langle E_{\text{loss}} \rangle}$$
- The separation between electrons, kaons, protons and pions is defined as

$$|\langle E_{\text{loss}} e, K, p \rangle - \langle E_{\text{loss}} \pi \rangle| / \sigma_{\pi}$$

ILD pixel TPC PID performance

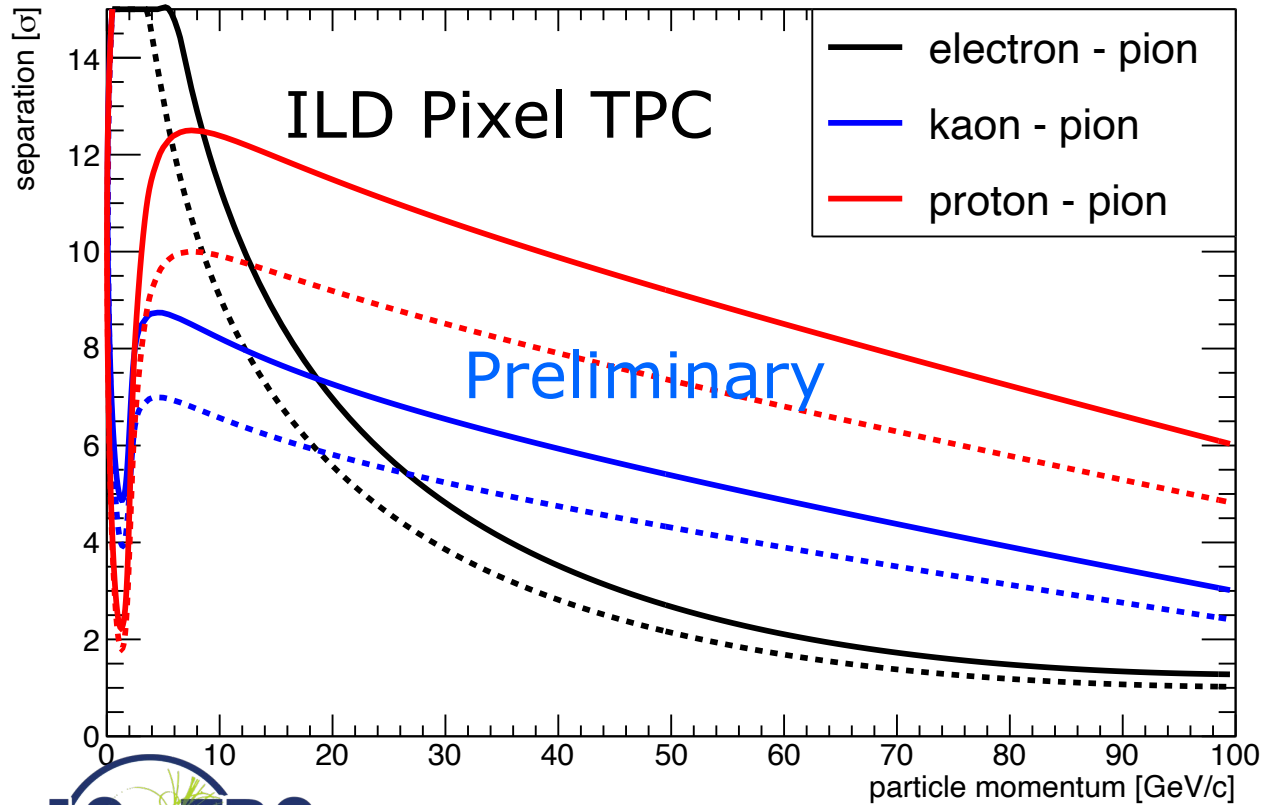

- ILD PID Performance for the two methods: template fit (solid), truncation (dashed)
- The expected pion-**kaon** PID separation for momenta in the range of 2.5-45 GeV/c at $\cos \theta = 0$ is more than **5.5(4.5) σ**
- At a momentum of 100 GeV/c the separation is still 3.0(2.0) σ
- The expected pion-**proton** PID separation for momenta in the range of 2.5-100 GeV/c at $\cos \theta = 0$ is more than **6.0(4.8) σ**

Simulation of ILD TPC with pixel readout

- To study the performance of a large pixelized TPC, the pixel readout was implemented in the full ILD DD4HEP (Geant4) simulation
- Changed the existing TPC pad readout to a pixel readout
- Adapted Kalman filter track reconstruction to pixels

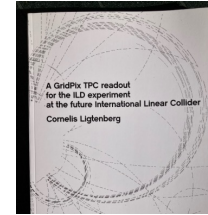

details: PhD [thesis](#)
Kees Ligtenberg

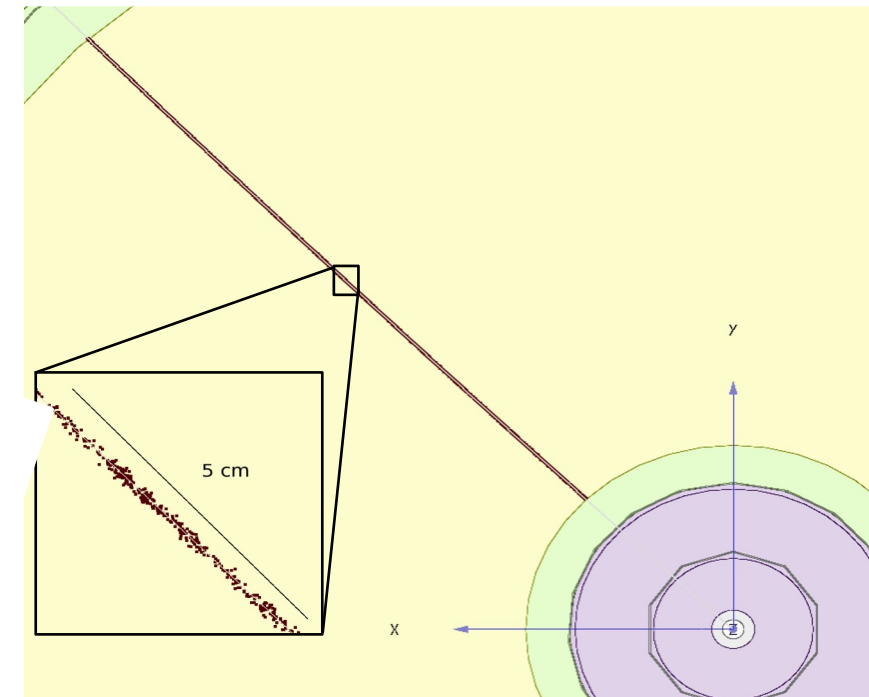
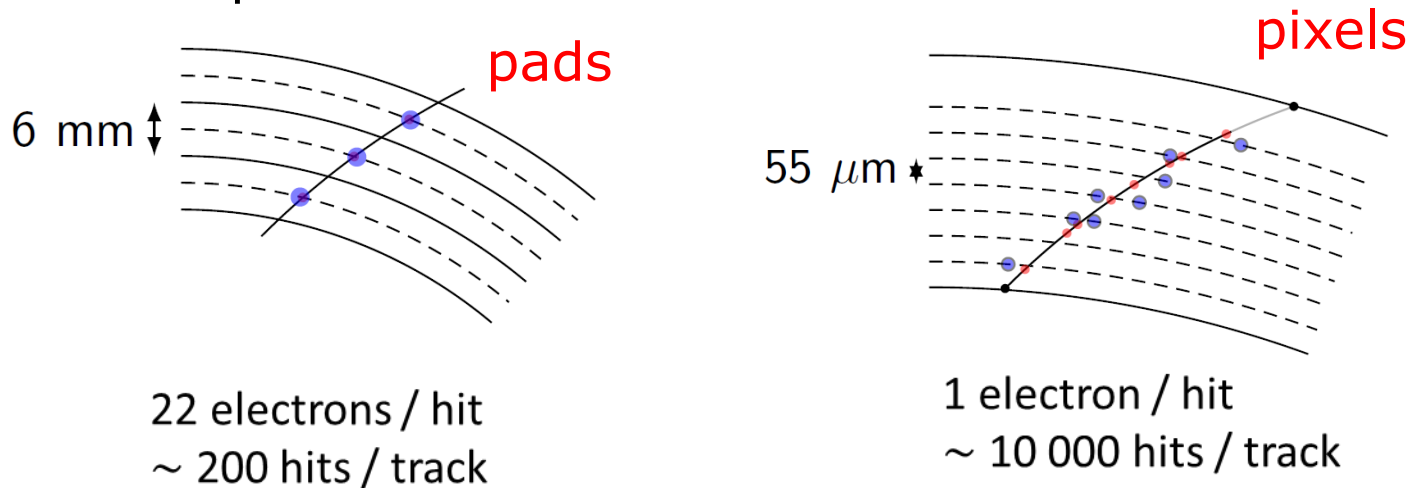

50 GeV muon track with
pixel readout

Performance of a GridPix TPC at ILC

- From full simulation the momentum resolution can be determined
- Momentum resolution is about 15% better for the pixels with realistic coverage (with the quads arranged in modules coverage 59%) and deltas.

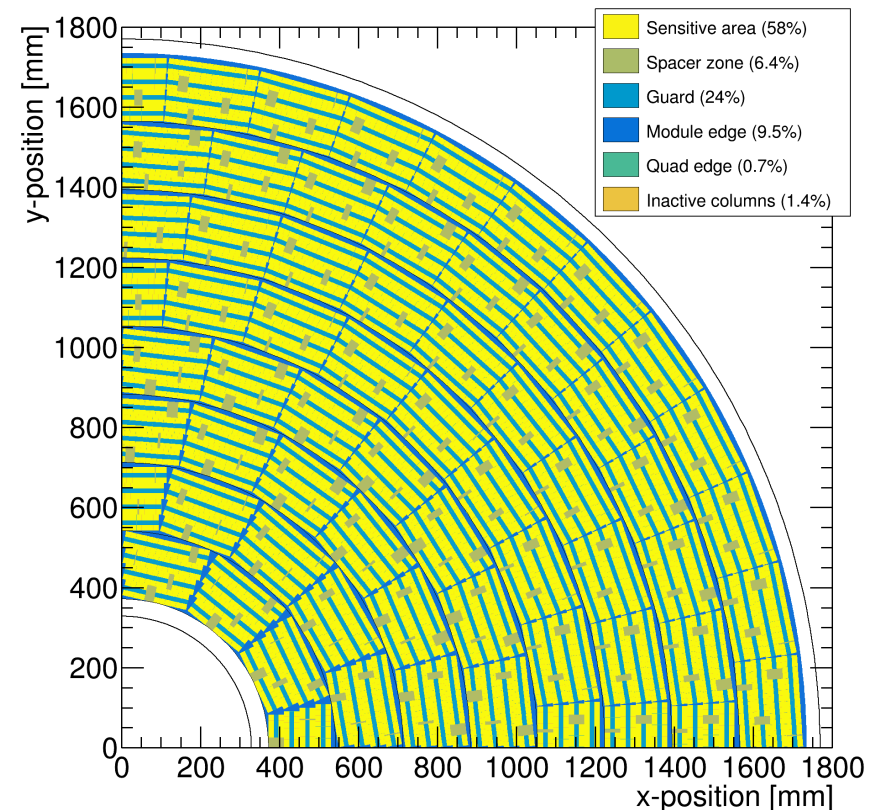
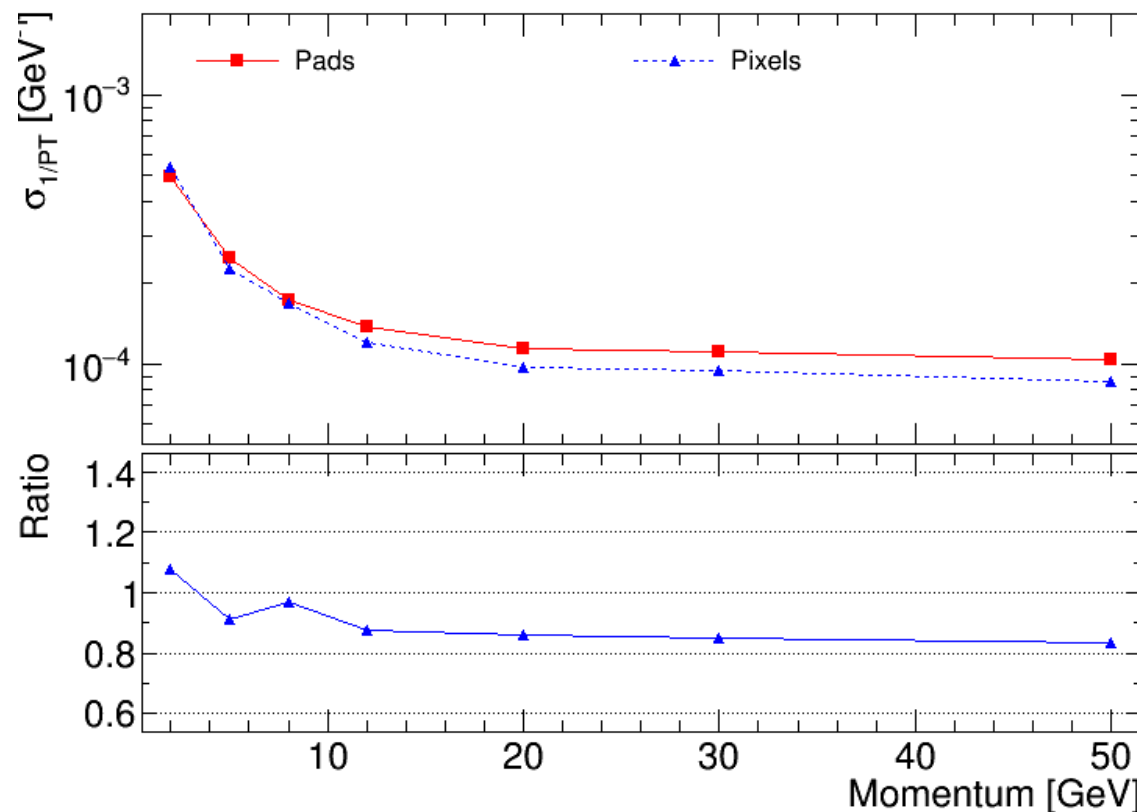

ILD tracking Performance for a Pixel TPC based on test beam

10 cm track resolution

Single electron resolution

6 mm track("pad") resolution

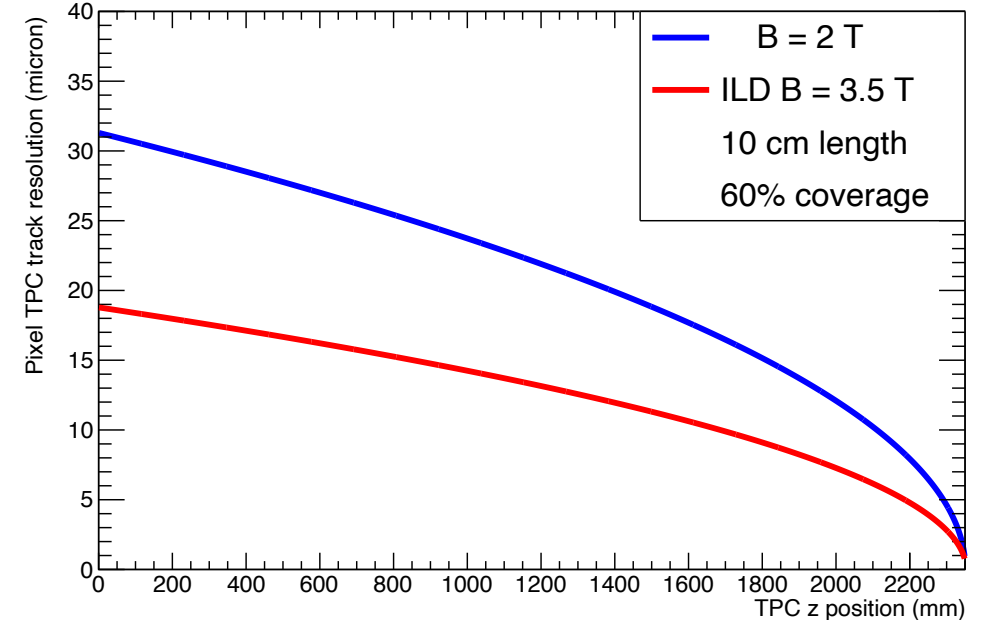

Each 10 cm we have a point with a resolution of < 18 (31) μm on the track
 Comparable to performance of a silicon detector (but TPC gas material).



Performance of a GridPix TPC

Further integration of the Pixel TPC in the ILD software

A thought by Frank Gaede about combining pixels into pads:

- one could easily project the pixels into pads - of similar/same size as in the current ILD simulation
- but rather than simply adding up the charge, you can compute the true center-of-gravity based position and charge of the virtual pad
- in a second step you combine neighbouring pads to a cluster and compute the position (in r - ϕ , z) of the cluster and create a SimHit from this
- both operations should be linear in time (i.e. one loop over pixels/pads)

This procedure should preserve all the point resolution information of the pixels but allow you to run standard Clupatra as for the pad based TPC reconstruction.

Pixel TPC: Track fitting at the edge

- In case of the a realistic geometry with detector edges, Kees Ligtenberg observed a worsened momentum resolution and momentum biases. This was traced down to be caused by biases in the residuals at the edge of the detector
- The conclusion was that the track fit should be updated to take into account the (small) biases in the residuals at the detector edge(s)
- Recently, a master student (computational physics) at the UvA, Peter Voerman, has written a track fit that corrects the biases in one pass: "Track fitting at the edge".
- The technique can also be applied to fit hits from other gaseous or non-gaseous detectors:
 - a centre of gravity technique is used (with measured charges over multiple strips near the edge)
 - in case of silicon detector hits near the boundaries of the sensitive volume

- The relative PID resolution for an electron with $p=5,6$ GeV/c and 1 m track length with 60% coverage is measured to be:
 - 2.9 (3.6)% using the template fit (truncation) methods at $B = 1$ T
- This is world-best resolution per meter of track length of constructed TPCs running at atmospheric pressure
- The extrapolated PID resolution for the ILD detector is 2.4 (3.0)%
- This allows for particle identification and separation of kaons from pions for momenta 2.5-45 GeV/c at $\cos \theta = 0$ with more than **5.5 (4.5) σ** .
- A pixel TPC has become a realistic viable option for experiments
 - High precision tracking like ILD@ILC in the transverse and longitudinal planes, dE/dx by electron and cluster counting, excellent two track resolution, digital readout that can deal with high rates

ILD Pixel TPC PID performance

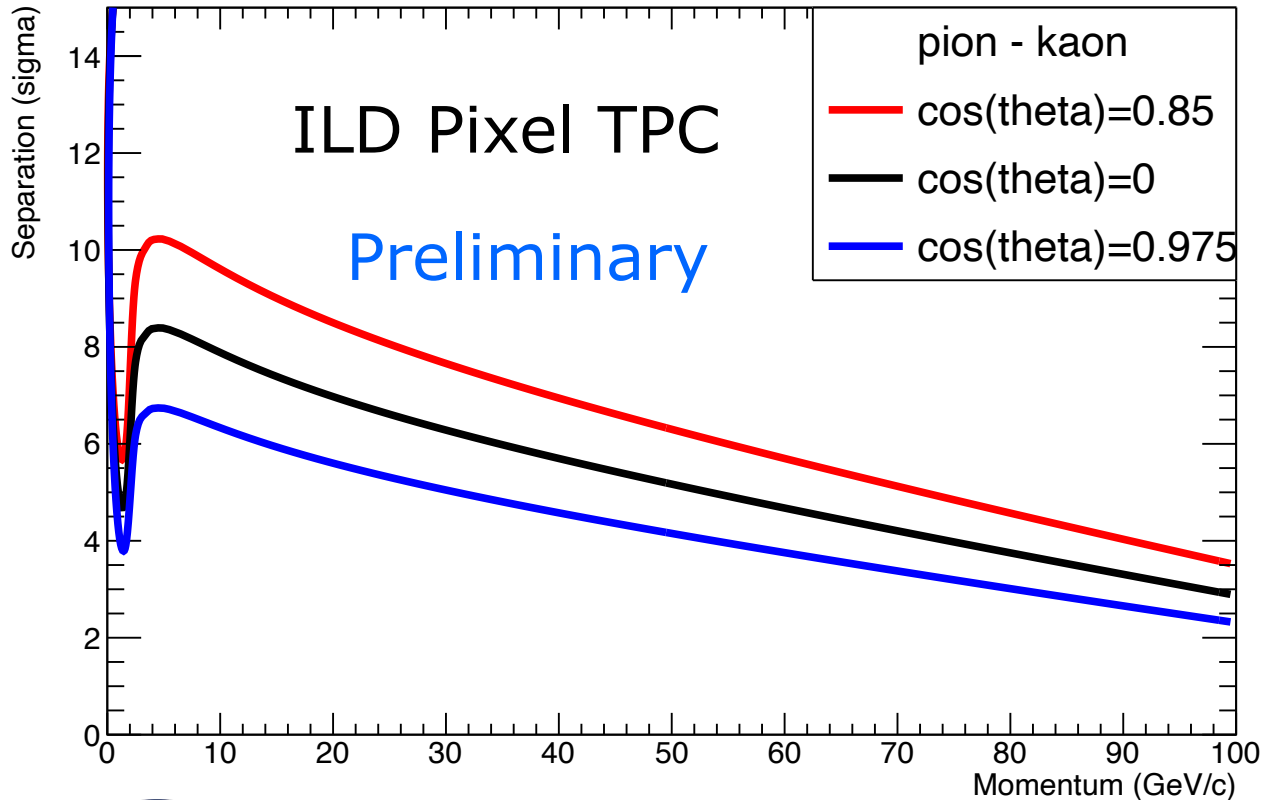

- Separation pion-kaon for different $\cos(\theta)$ values due to the track length dependence
- For $\cos(\theta)=0$ till 0.95 the separation lies between the black and red curves. Only above 0.95-0.975 the separation drops till the blue curve.
- Excellent performance over very large polar angle range

- ▶ Close to the edge of a detector, measurements of the particle's position are biased, leading to biased track parameters during track fitting
- ▶ The bias in the measurements can be described by this equation:

$$c = \begin{cases} 0 & \text{if } x < p_1 \\ \frac{(x-p_1)^2}{p_0} & \text{if } p_1 < x < p_2 \\ \frac{2(p_2-p_1)(x-p_2)}{p_0} + \frac{(p_2-p_1)^2}{p_0} & \text{if } p_2 < x \end{cases} \quad (1)$$

- ▶ p_0 , p_1 and p_2 are dependent on the amount of diffusion in the detector and the detector geometry

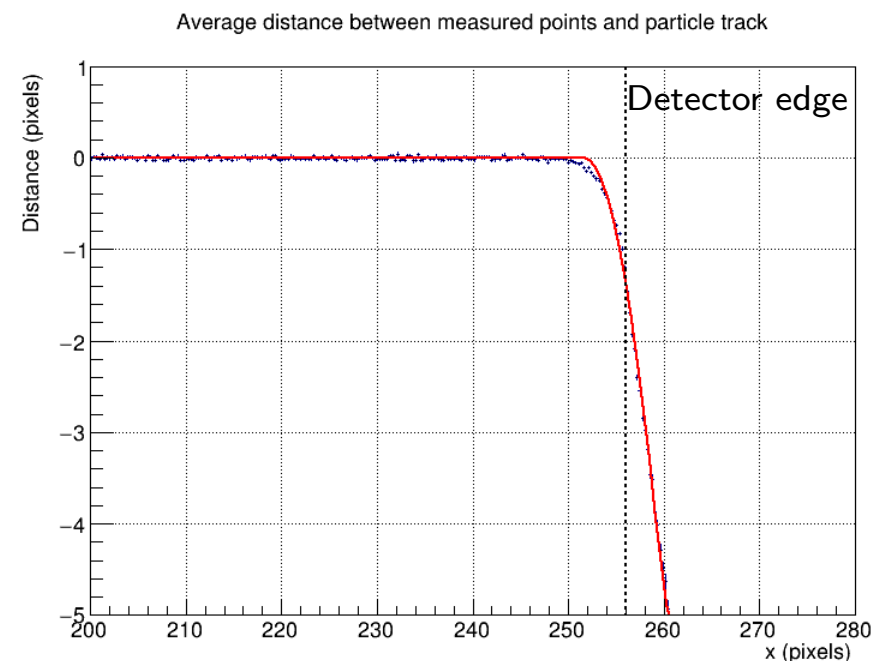

Pixel TPC: Track fitting at the edge



Correcting bias on the detector edge

Peter Voerman

- ▶ The fit is done by minimizing the following χ^2 :

$$\chi^2 = \sum_{i=1}^N \frac{(\sin(\phi)(x_{m,i} - c_i) - \cos(\phi)y_{m,i} - d_0)^2}{\sigma_i^2} \quad (2)$$

- ▶ Without correction, $c_i = 0$
- ▶ With correction, c_i is calculated using equation 1
- ▶ As seen in the figures, this correction significantly reduces the bias in the fitted parameters as the fraction of measurements close to the edge increases

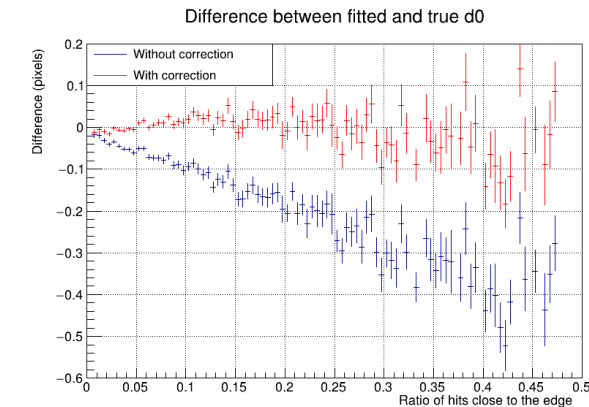
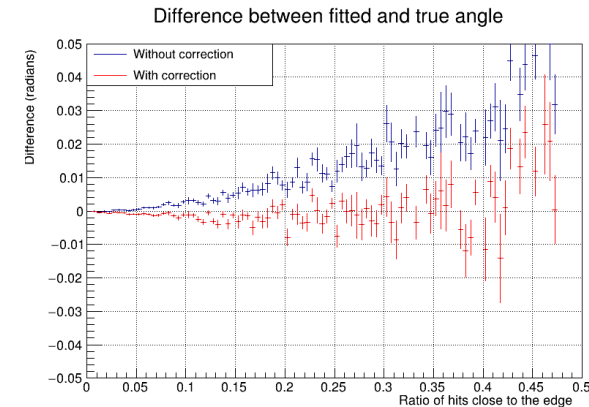

Operation of a Pixel TPC at CEPC or FCC-ee

A Pixel TPC at CEPC or FCC-ee

The most difficult situation for a TPC is running at the Z.

At the Z pole with $L = 200 \cdot 10^{34} \text{ cm}^{-2} \text{ s}^{-1}$ Z bosons will be produced at $\sim 60 \text{ kHz}$

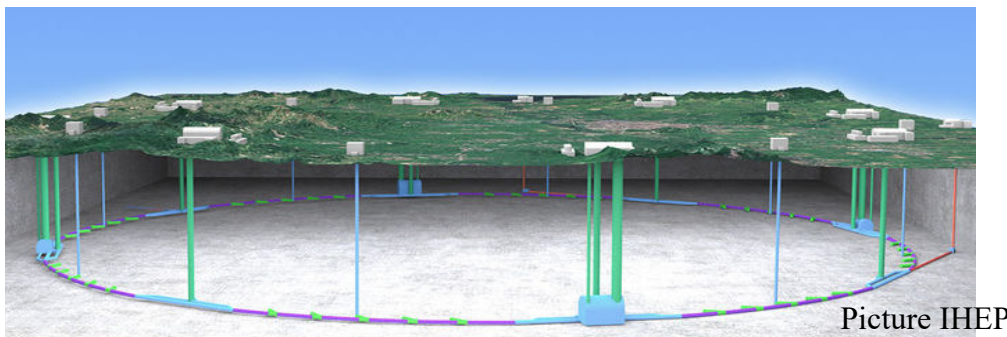

Picture IHEP

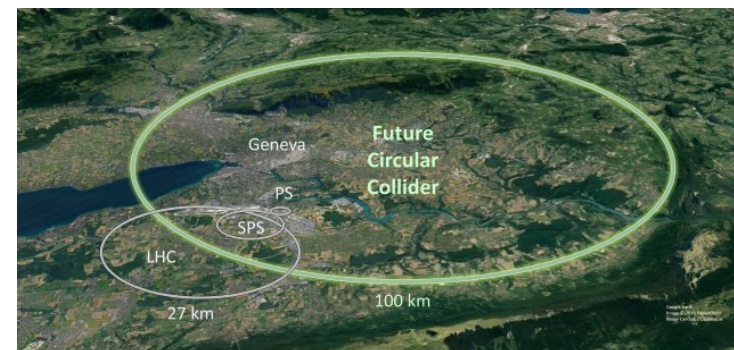

■ Can a pixel TPC reconstruct the events?

- The TPC total drift time is about $30 \mu\text{s}$
- This means that there is on average 2 event / TPC readout cycle
- YES: The excellent time resolution: time stamping of tracks $< 1.2 \text{ ns}$ allows to resolve and reconstruct the events

■ Can the current readout deal with the rate?

- Link speed of Timepix3 (in Quad): 2.6 MHits/s per $1.41 \times 1.41 \text{ cm}^2$ Testbeam up to 1.5 kHz
- YES: This is sufficient to deal with hits from Z's in high luminosity Z running
- NB: Data size is not a show stopper as e.g. LHCb experiment shows using the VeloPix chip

A Pixel TPC at CEPC or FCC-ee

- What is the current power consumption?
 - No power pulsing possible at these colliders (at ILC power pulsing was possible)
 - Current power consumption TPX3 chip $\sim 2\text{W}/\text{chip}$ per $1.41 \times 1.41 \text{ cm}^2$
 - So: good cooling is important but in my opinion no show stopper
 - For Silicon detectors lower consumption for the chips and cooling is an important point that needs R&D (e.g. microchannel cooling).
 - To save power the TPX3/4 chips can be run in LowPowerMode: reduction factor 10.
- Can one limit the track distortions?
 - There are two important sources of track distortions:
 - the distortions of the TPC drift field due to the primary ions
 - the distortions of the TPC drift field due to the ion back flow (IBF)
 - At the ILC gating is possible; for CEPC or FCC-ee this is more involved, for a Pixel TPC a double grid is the best solution (see next slide)

A Pixel TPC at CEPC or FCC-ee

- **Is it possible to reduce the IBF for a pixel TPC?**
 - IDEA: by making chip with a double grid structure (see back up slide)
 - This idea was already realized as a TWINGRID NIMA 610 (2009) 644-648
 - For GEMs for the ALICE TPC this was also the way – several GEMs on top of each other to reduce IBF
 - For the Pixel the IBF can be easily modelled and with a hole size of 25 μm an IBF of $3 \cdot 10^{-4}$ can be achieved and the value for $\text{IBF} \cdot \text{Gain} (2000)$ would be 0.6.
 - YES: the IBF can be reduced to 0.6 but this needs R&D
 - In the new detector lab in Bonn it is possible to make and study this device
- **What would be the size of the TPC distortions?**
 - Tera-Z studies by Daniel Jeans and Keisuke Fuji show that for FCC-ee or CEPC this means: distortions from Z decays up to $< O(100) \mu\text{m}$
 - Beam strahlung gives (now) a factor 200 more hits in the TPC. See Daniel Jeans studies in ECFA2024. Detector optimization and shielding is important for TPC and Silicon detectors to reduce pair background. A recent study shows the potential.
 - It was argued that in an ILD like detector the distortions can be mapped or fitted out using the VTX-SIT/SET detectors (see next slide).

Fitting out TPC distortions in ILD/CEPC

- It is possible to map out distortions using e.g. muons from Z decays
 - E.g. by fitting the 3D spatial distribution as a function of time as was done by ALEPH and more recently by ALICE. Using this distribution the hits positions are corrected and the TPC track refitted.
- However, with silicon trackers around the TPC, more elaborate methods can be used. One can use the track predictions based of the silicon trackers SIT and SET to correct on a track-by-track level the TPC track.
 - One can use as a constraint that the extrapolated positions and angles agree with the measured in the SIT and SET.
 - Practically, one can e.g. correct the TPC track parameters
- The ultimate way is a fitting technique similar to ATLAS. In the ATLAS track fit the common systematics is fitted out for sets of Muon hits. For ILD/CEPC the fit would fit free parameters in the distortion model, while using as a constraint the SIT and SET position and direction measurements.
 - The simplest case is a model where the strength (amplitude) and radial dependence would be scaled and a model is used for the 3D extrapolations.

Conclusions: Pixel TPC at CEPC or FCCee

- YES: a pixel TPC can reconstruct the Z events in one readout cycle
- YES: the current **readout** of the Timepix3 chip can deal with the Z hit rate running
 - The beam-beam background currently dominates the hit rate
- The current **power consumption** is $1\text{W}/\text{cm}^2$. By running the TPX chips in low power mode this can be reduced by a factor of **10**. Still good **cooling** is important no show stopper.
- Track distortions in the TPC drift volume are a concern at high lumi Z running:
 - Track distortions from Z decays in TPC are $O(100)\ \mu\text{m}$
 - The current MDI design FCCee/CEPC gives a lot of beam-beam background more than a factor 100 more hits from the beam than from the Z. **An improved MDI is needed. Also a high B field (say 3 T) would help (now an option at FCCee).**
 - It is possible to reduce the IBF for a pixel TPC by making a device with a **double grid**
 - A double grid needs dedicated R&D that can be performed in the new lab in Bonn
- The Z physics program at FCC-ee or CEPC with an ILD-like detector with a Pixel TPC (with double grid structures) sliced between two silicon trackers (VTX-SIT and SET) can be fully exploited. The reduction of beamstrahlung by an improved MDI – and the fitting out of distortions - needs more study.
- A pixel TPC can perfectly run at WW, ZH or tt energies where track distortions are several orders of magnitude smaller

Reducing the Ion back flow in a Pixel TPC

The Ion back flow can be reduced by adding a second grid to the device. It is important that the holes of the grids are aligned. The Ion back flow is a function of the geometry and electric fields. Detailed simulations – validated by data – have been presented in [LCTPC WP #326](#).

With a hole size of 25 μm an IBF of $3 \cdot 10^{-4}$ can be achieved and the value for IBF*Gain (2000) would be 0.6.

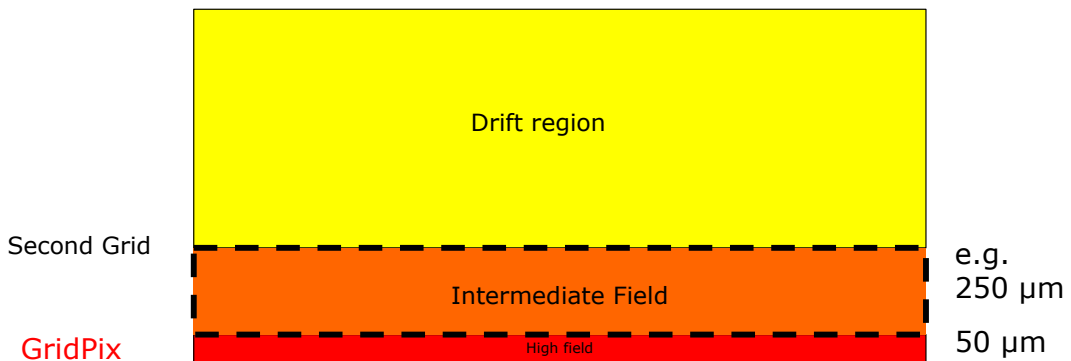

Ion backflow	Hole 30 μm	Hole 25 μm	Hole 20 μm
Top grid	2.2%	1.2%	0.7%
GridPix	5.5%	2.8%	1.7%
Total	$12 \cdot 10^{-4}$	$3 \cdot 10^{-4}$	$1 \cdot 10^{-4}$
transparancy	100%	99.4%	91.7%

