

SiD Silicon-Tungsten ECal Update

Frey/Strom
Aug 28, 2006

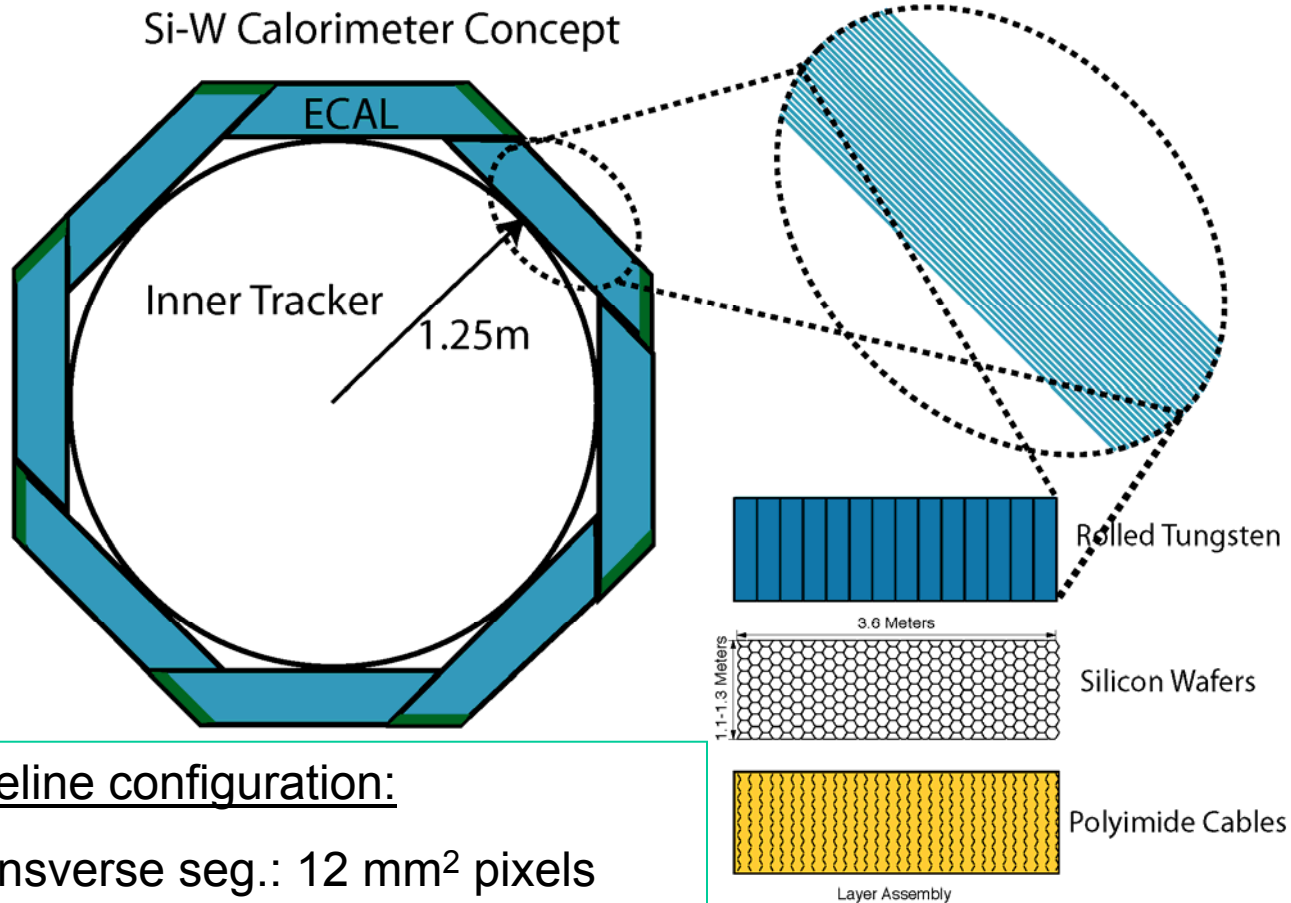

Baseline configuration:

- transverse seg.: 12 mm² pixels
- 1 mm readout gaps
- longitudinal: $(20 \times \frac{5}{7} X_0) + (10 \times \frac{10}{7} X_0)$
- EM resolution: 17% /sqrt(E)

Si/W ECal R&D Collaboration

M. Breidenbach, D. Freytag, N. Graf, R. Herbst, G. Haller, J. Jaros, T. Nelson
Stanford Linear Accelerator Center

J. Brau, R. Frey, D. Strom, M. Robinson, A. Tubman
U. Oregon

V. Radeka
Brookhaven National Lab

B. Holbrook, R. Lander, M. Tripathi
UC Davis

S. Adloff, F. Cadoux, J. Jacquemier, Y. Karyotakis
LAPP Annecy

- KPiX readout chip
- downstream readout
- detector, cable development
- mechanical design and integration
- detector development
- readout electronics
- readout electronics
- cable development
- bump bonding
- mechanical design and integration

Status/News

- KPiX readout chip (64 chan prototypes)
 - v2 prototype functions (with quirks)
 - Under evaluation at SLAC and Oregon
 - v3 submitted 7/ 27/ 06
 - Trigger (for tests)
 - Inverter (for GEMs)
- Incremental progress on prototype Si detectors in lab
 - Ready to submit v2
 - Is compatible with KPiX-1024
- Flex readout cable v1 design ready
- Tech prototype(s): KPiX-v2/3 + Si-v1 + flex-v1 ← Bump bonding (Davis)
- Full-depth module: KPiX-v1024 + Si-v2 + flex-v?
- LCDRD supplementary proposal subm 7/06
 - for Si-v2 detectors, bump bonding, flex cables
 - Oregon and Davis: 2x150k\$

KPiX-v2: first bench results

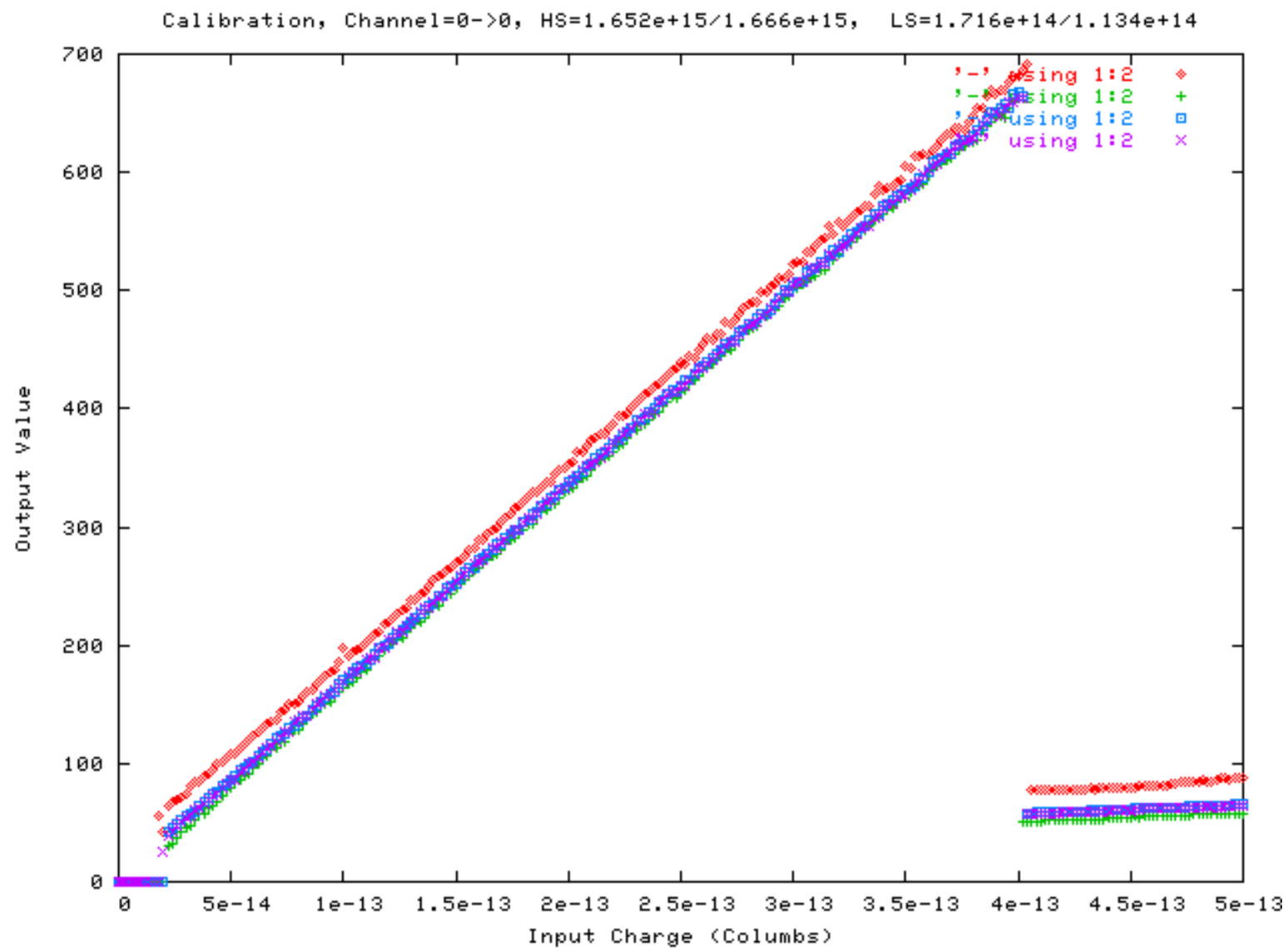

ECal R&D Plan (Outline)

status

1 st round prototype detector dev. and testing	2004-6	Oregon	✓
KPiX prototypes chip design mods and bench testing	2006	SLAC, Oregon	v2, under test v3, subm 7/06
Develop and fab kapton readout cable	2006	UC Davis	✓ dev
B. bond KPiX-v3 to v1 detectors and flex cables – test in lab and in electron beam	Late 2006	UC Davis, Oregon	Beams at SLAC ????
Design and order v2 detectors (40) for full-depth ECal module	2006	Oregon	on track
Develop concentrator boards	2006	SLAC	
KPiX-v4 check all fixes for v1024 version	Late 2006	SLAC	
Full mechanical design for prototype	2006	Annecy	
Mechanical and magnetic field tests	2006-7	All	
<i>Order full 1024 channel KPiX</i>	Early 2007	SLAC	Ok so far
<i>Bump bond KPiX-v1024 to Si-v2</i>	2007	UC Davis	Non-trivial
Fab. ECal module; test in electron beam: determine EM response	2007	All	on track (I think)
ECal module + HCal module in hadron beam (presume FNAL) – G4 validation	2008 ?	All	

High Priority Simulation & Reconstruction Tasks

- EM Energy Resolution

Study energy resolution as a function of EM depth and hadronic calorimeter segmentation and sampling method.

How well can the HCAL measure EM leakage.

- Segmentation

Develop 3d clustering

Goal -- separate 10 GeV EM clusters spaced at $\sim 1/2$ RM (~ 7 mm)

(achieved by OPAL)

- Tracking issues

Develop tracking enhancements for backscatters and K0s

Evaluate MIP -- EM cluster accidental matching

Goal ??

Develop optimal method of MIP--EM cluster association

Evaluate mip tracking efficiency in the calorimeter

Goal - >95% efficiency

High Priority Simulation & Reconstruction Tasks (cont.)

- Electron ID in heavy quark events

Missing energy from neutrinos due to semileptonic decays of heavy quarks is almost as large an effect as neutral hadrons.

If the associated electron or muon can be identified, can a correction be applied resulting in better energy flow?

High Priority Physics Studies

- Tau Polarization

What physics processes require good tau id and polarization measurements?
(eg hep-ph/0507100)

Is the segmentation of SiD good enough for tau polarization?

- Energy flow

What physics processes really require $30\%/\sqrt{E}$ jet energy resolution?
If only $60\%/\sqrt{E}$ is needed, is another kind of EM calorimeter better?

- Final states with electrons and photons

What physics processes require $16\%/\sqrt{E}$ EM resolution?

Forward Region ECAL/HCAL Interface

- SiD Forward Region

SiD forward region group is off to a good start (BNL + others)

- SiD Endcap barely studied

- Rate limits in ECAL/HCAL should be studied

- Physics impact of jet resolution in this region in physics needs to better developed.