

FID Based Pulse Generators for Accelerator Applications

Vladimir M. Efanov

*FID GmbH, 25 Werkstrasse,
Burbach, D-57299, Germany
vlad@fidtechnology.com*

2006

Fields of Activity

FID Technology

Peak power - up to 10 GW
Pulse width - 100-500 ps



Ultrawide bandwidth radars

Peak power 1 - 100 MW
Pulse width - 10 - 100 ns



Plasma chemistry

Peak power - 0,1-10 MW
Maximum PRF - 1-10 kHz



High PRF Picosecond Pulsers

Maximum voltage - 5-10 kV
Pulse width 0,1-100 ns



Pockels Cell and Laser Diode Drivers

Peak current - up to 100 kA



All Solid State Turn-on FID Switches

Turn-on FID Switches

FID Turn-on Switches



Picosecond FID Switches

Operating voltage - 1-10 kV

Turn-on time - 50-200 ps



FID Marx Pulse Generators

Operating voltage - up to 1000 kV



High Power FID switches

Peak current - up to 100 kA

Operating voltage - 1-50 kV

Turn-on time - less than 2-3 ns

FID Solid State Switches

- FID “turn-on” switches
 - Turn-on time of less than 100 ps
 - Operating voltage of different types of FID switches ranges from 100 V to 50 kV pulsed voltage
 - FID can be stacked to achieve voltages from tens to hundreds of kilovolts. Rise time in this case varies from several hundreds of picoseconds to tens of nanoseconds
 - Timing jitter is less than 20 ps
 - Maximum operating voltage in stack is more than 100 kV
 - Maximum operating current is more than 100 kA
 - Maximum PRF is more than 500 kHz

DRD Solid State Switches

- DRD “turn-off” switches
 - Maximum operating voltage in stack can be more than 100kV
 - Maximum operating current is more than 10 kA
 - Turn-off time is 0,5 – 10 ns
 - Maximum PRF is more than 1 MHz

World Priorities of FID Tech – FPM 30-10



- Output voltage 30 kV – 70 kV
- Rise time 100 – 150 ps
- Pulse duration 0,5 – 1 ns
- Peak power of up to 100 MW
- Synchronization of a large number of modules with a 20-30 ps accuracy

World Priorities of FID Tech – FPM 10-50



- | | |
|------------------------|------------------|
| Maximum output voltage | - 10 kV |
| ✓ Rise time | - 100-120 ps |
| ✓ Pulse width | - 1 ns |
| ✓ Maximum PRF | - 50 kHz |
| ✓ Input voltage | - DC 48/200 V |
| ✓ Triggering | - External, 20 V |

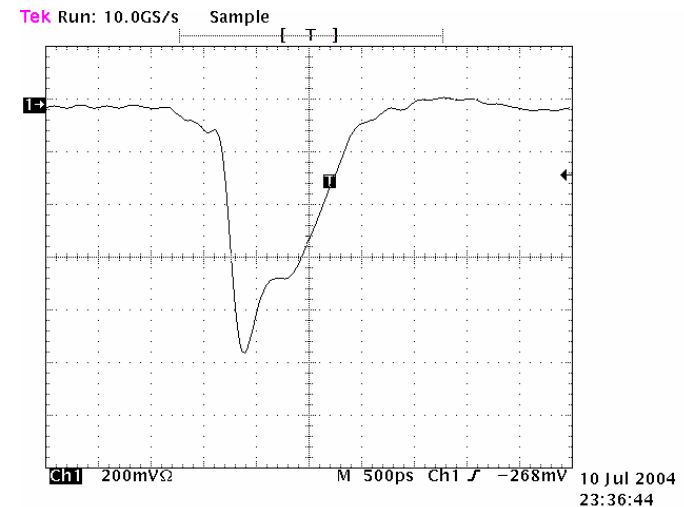

World Priorities of FID Tech – 10 kV, 20 Picosecond Rise Time

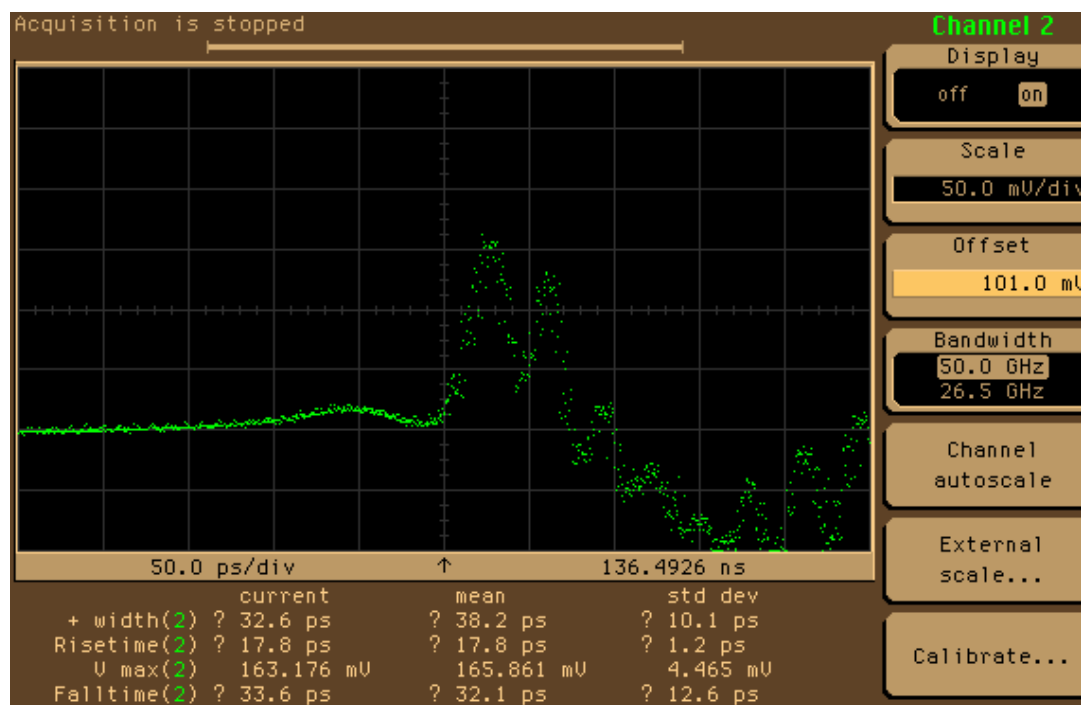

Attenuators used in measurements:

- FID GmbH 40 dB 26 GHz
- Weinschel 30 dB and 6 dB 40 GHz
- Transmission line – 18 GHz

Rise time 0,1-0,9 U_{max} – 17,6 ps

World Priorities of FID Tech – 5 kV, 25 Picosecond Rise Time

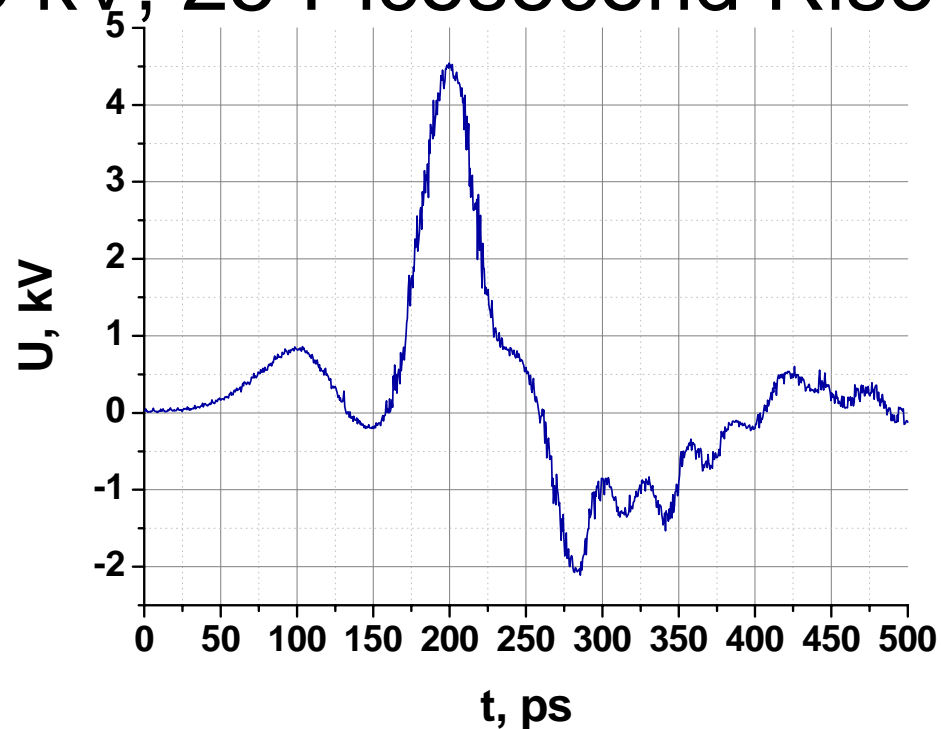

Attenuators used in measurements

- FID GmbH 20 dB, 18 GHz
- Weinschel 10 dB 18 GHz
- Weinschel 30 dB and 20 dB 40 GHz
- Transmission line 18 GHz

Rise time 0,1-0,9 U_{\max} – 25 ps

World Priorities of FID Tech – FPG 60-100MC4

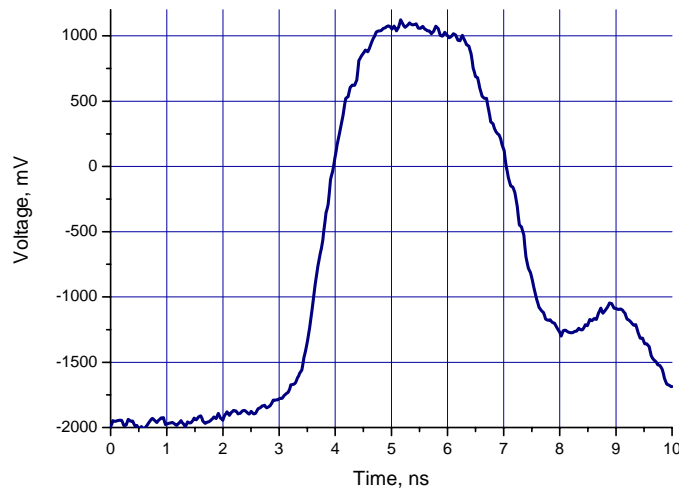

- Output voltage – 60 kV between positive and negative channels
- Rise time – 1-1,5 ns
- Pulse width at 90% - 2 ns
- Fall time – 2-3 ns
- Maximum PRF – 100 kHz

World Priorities of FID Tech – FPG 5-3000M

5 kV, 3 MHz, 2 ns

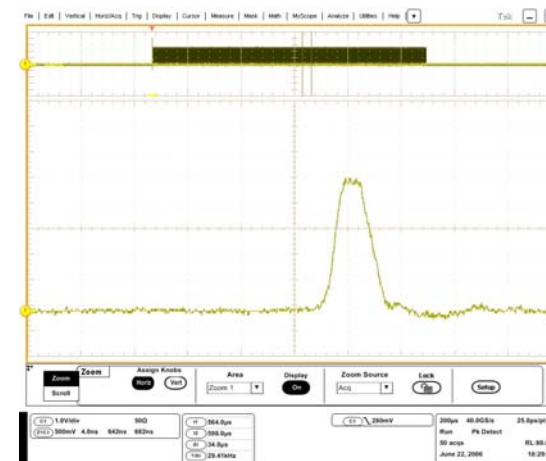
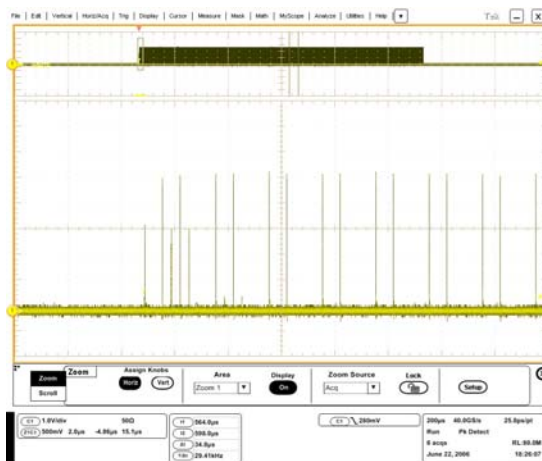
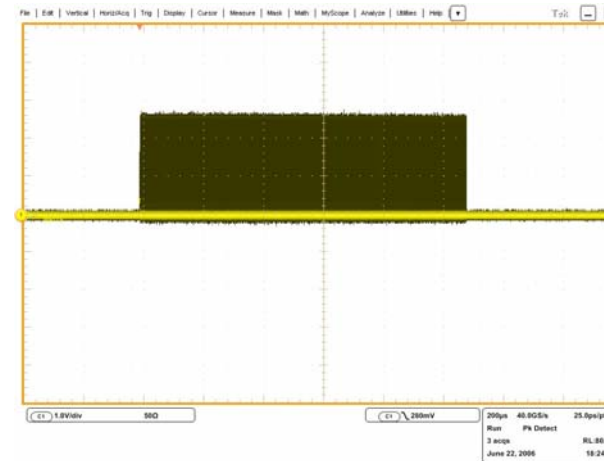

World Priorities of FID Tech – FPG 1-3000MC2 (+/- 1 kV, 3MHz, 2 ns)

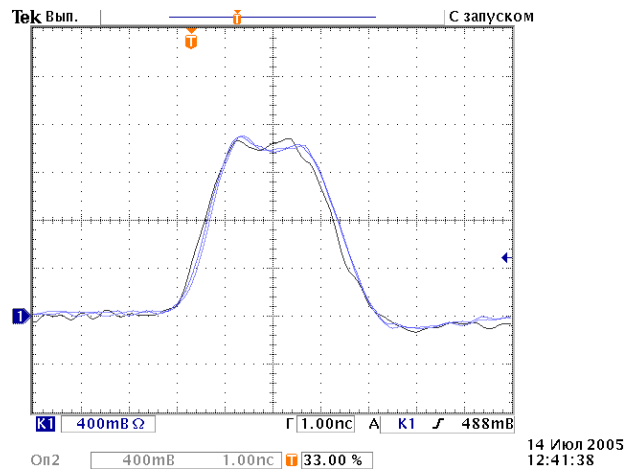
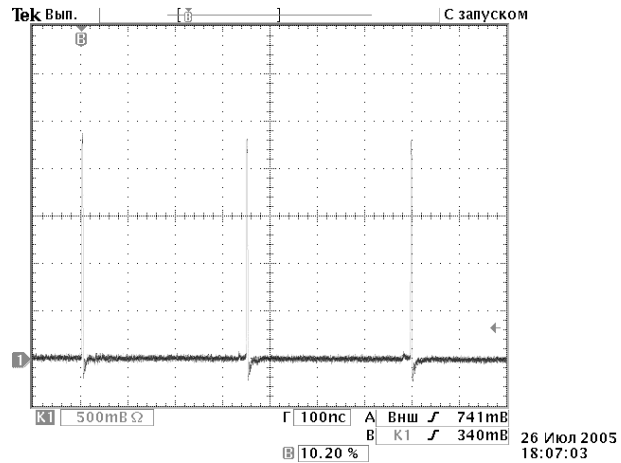

Specifications Necessary to Drive the Stripline Kicker of the ILC

- Output voltage – 10 kV at 50 Ohm
- Rise time 10-90% of U_{max} – 0,8-0,9 ns
- Pulse duration at 90% of U_{max} – 1,5-1,4 ns
- Fall time 90-10% of U_{max} – 1,5-2 ns
- Maximum PRF in burst mode – 6,5 MHz
- Maximum PRF of burst – 5 Hz
- Burst duration – 1 ms
- Jitter – 20-30 ps
- Peak Power – 2 MW
- Average power in burst – 25-50 kW
- Average power in load – 150 W
- Flat top stability – 0,3 %

10 kV, 6 MHz, 2 ns Design Idea

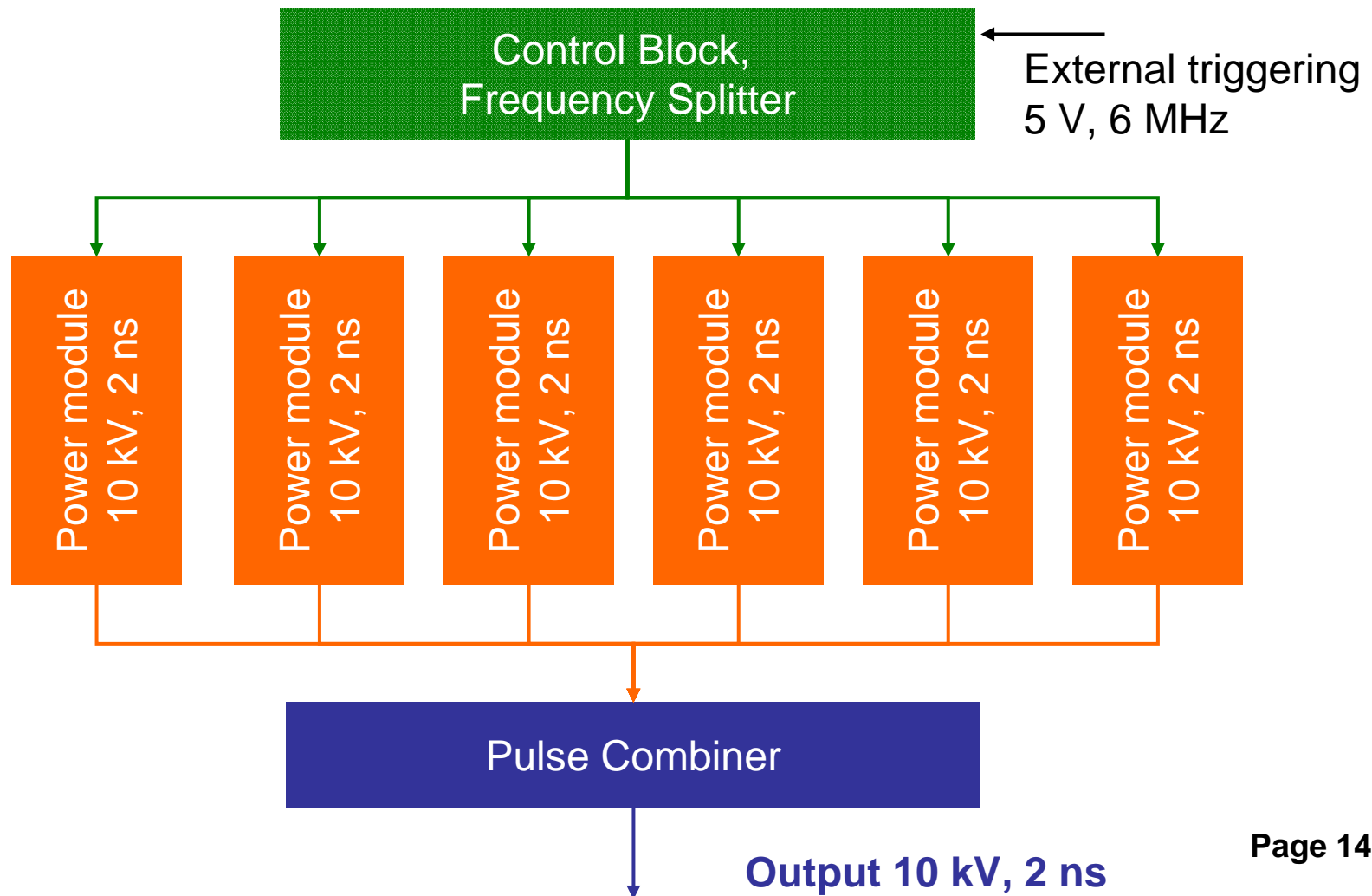

Design Overview of FPG 5-3000M

5 kV, 3 MHz, 2 ns

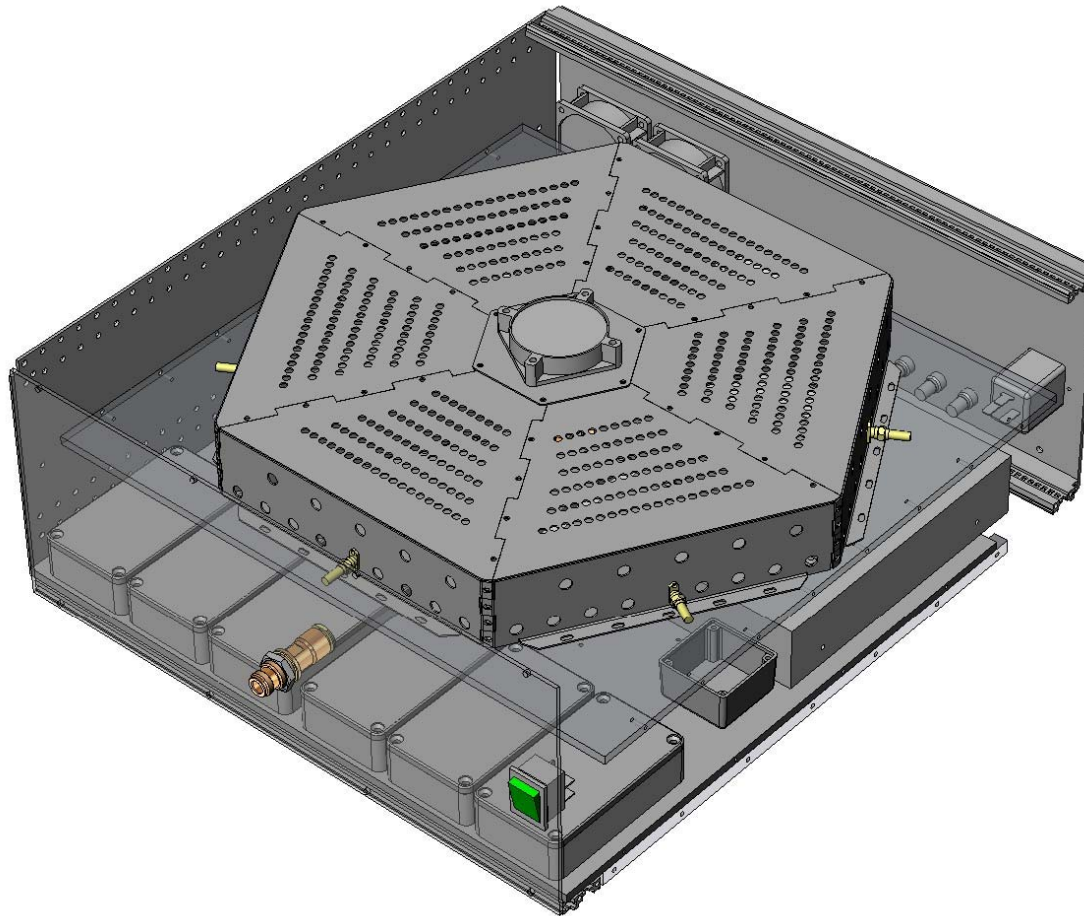

Built in 2005

10 kV, 6 MHz, 2 ns System Overview

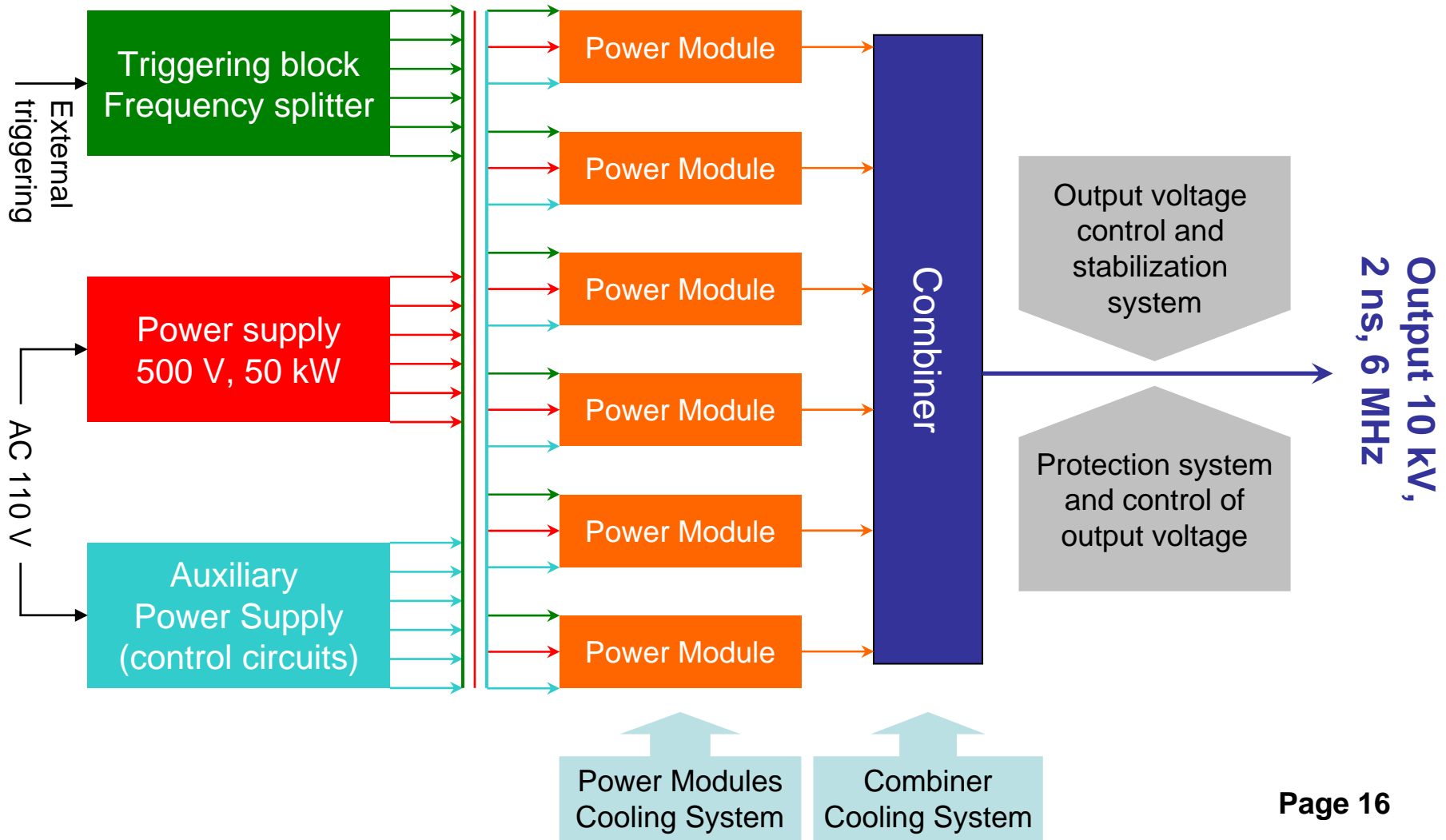

10 kV, 1 MHz, 2ns Module Block Diagram

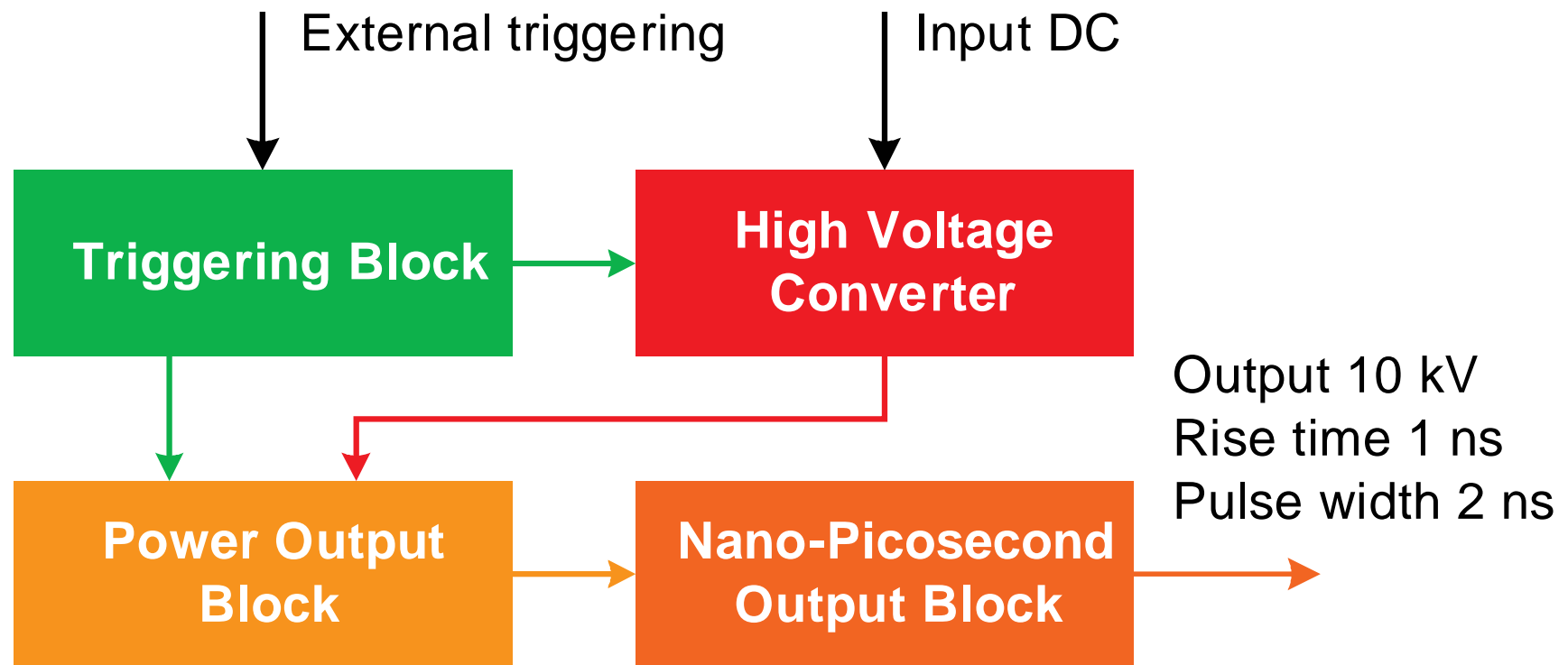

10 kV, 1 MHz, 2 ns Module Circuit Diagram

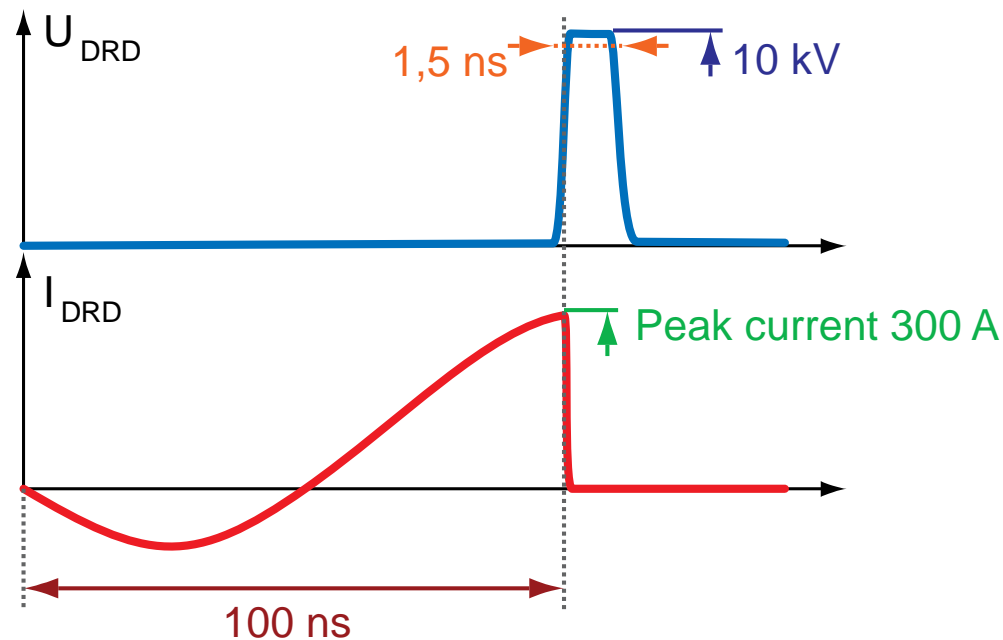
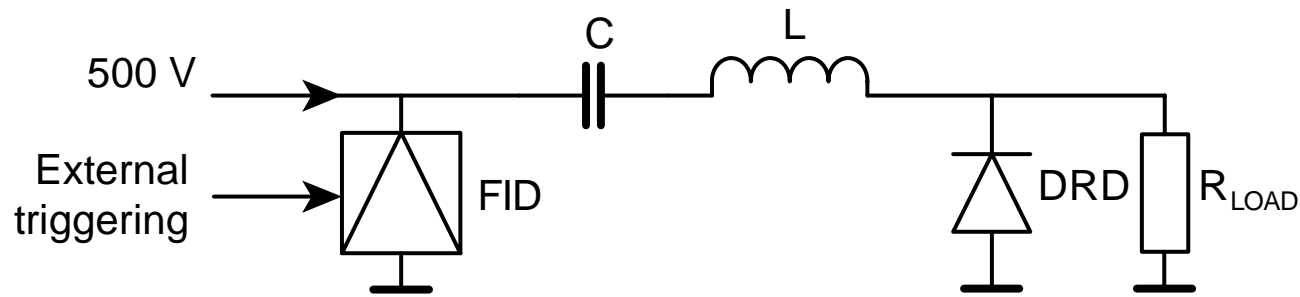

Estimated Module Overview

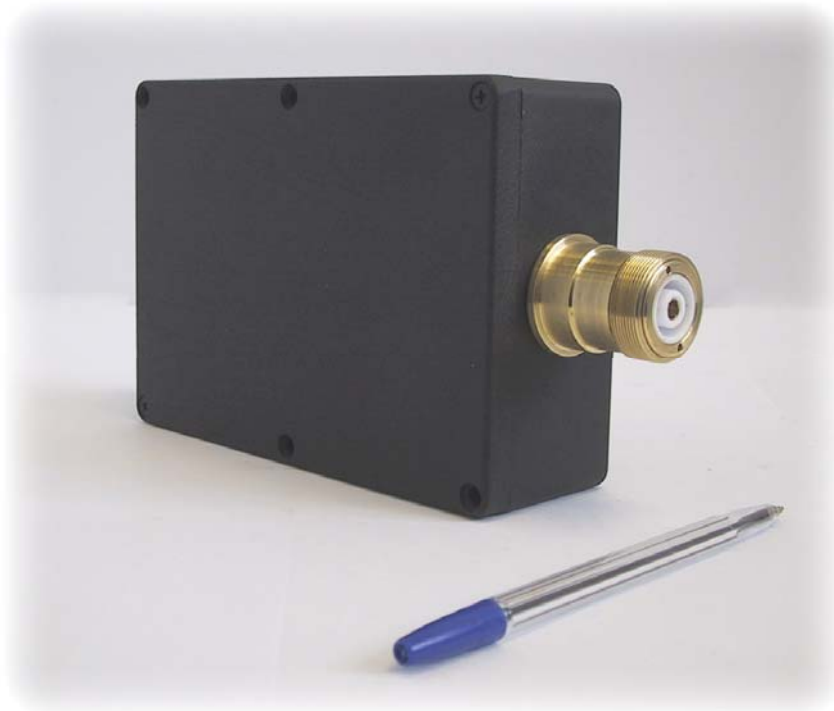

- Maximum amplitude into 50 Ohm – 10 kV
- Rise time – 1 ns
- Pulse duration at 90% - 1,4-1,5 ns
- Triggering external – 20-30 V, 50 ns
- Maximum PRF in burst – 1 MHz

Main Tasks Solved in Project

- Development of a power module 10 kV, 2 ns, 1 MHz
- Development of supporting subsystems:
 - control subsystem
 - stabilization subsystem
 - protection subsystem
- Development of cooling system
- Development of power supplies
- Development of measurement methodology for the accuracy of 0,3 % of maximum voltage
- Development of the generator design

Personnel Roster

1	Senior specialist	2	man-months
2	Nanosecond technology design engineer	6	man-months
3	Digital controllers design engineer	4	man-months
4	Power supply design engineer	6	man-months
5	Semiconductor processing engineer	3	man-months
6	Design engineer	2	man-months
7	Technicians and lab assistants	12	man-months

Total:

Total labor cost of qualified engineers	23	man-months
Total labor cost of technicians	12	man-months

Summary

- In different pulse power systems implemented stand-alone specifications necessary for stripline project
 - Amplitude of 10 kV
 - Rise time of 1 ns
 - Pulse duration at 90% of U_{max} – 2 ns
 - PRF – 6 MHz
 - Stability of about 1 %
- Available technical solutions allow providing of all necessary specifications in a single system
- Implementation time of a project is 6-8 months