

HFCAL-JP Focused Topic

April 7, 2027

Fumihito Ikeda, Tomoya Iizawa, Takahiro Kawahara, Yifu Zhang, Taikan Suehara, Takumi Seino (UTokyo)
Yosuke Takubo (Niihama College)
Akimasa Ishikawa, Hiroshi Iwase, Yuichi Okayasu, Yasuhiro Sakaki, Fusashi Miyahara, Yu Morikawa (KEK)
Akiko Iwasaki (Osaka Metropolitan U., RCNP Osaka U.), Kosuke Uemura (Osaka Metropolitan U.)
Hidetoshi Otono (Kyushu U.)
Takahiro Fusayasu, Aoi Masaki (Saga U.)

EBES

- **E**lectron **B**eam dump **E**xperiment at KEK Linac **S**witching Yard 3
- Searching **Axion-like particles in MeV-GeV region** using e^+/e^- beam and fixed-target
 - Signal: $\alpha \rightarrow 2\gamma$
- The first physics run is conducted in 2025

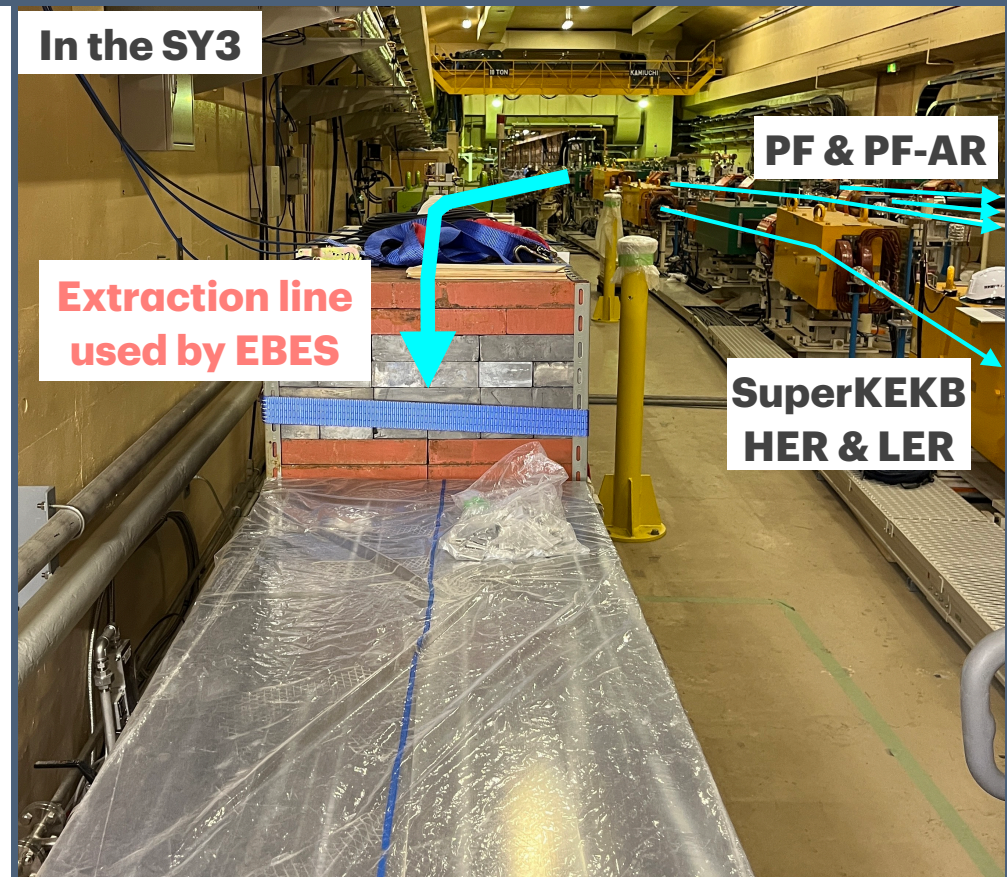
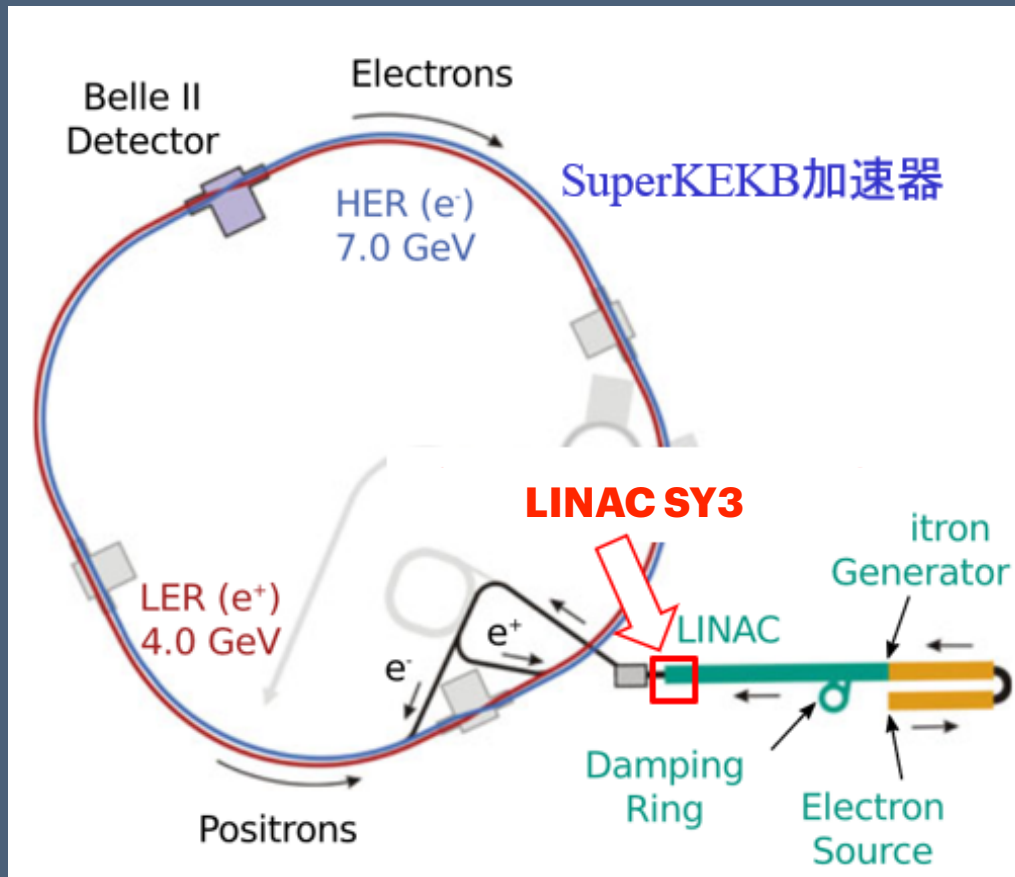
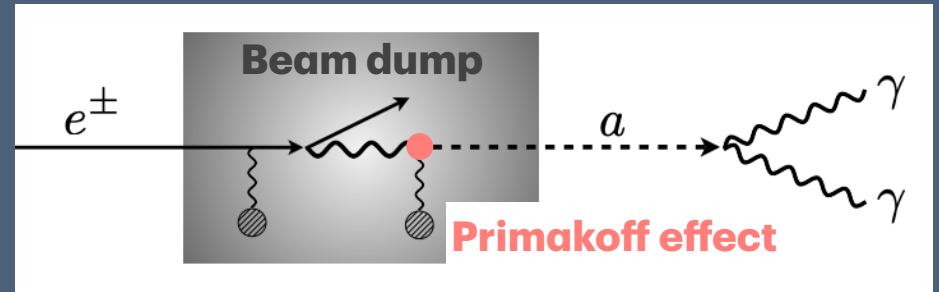

Pilot Run in 2023

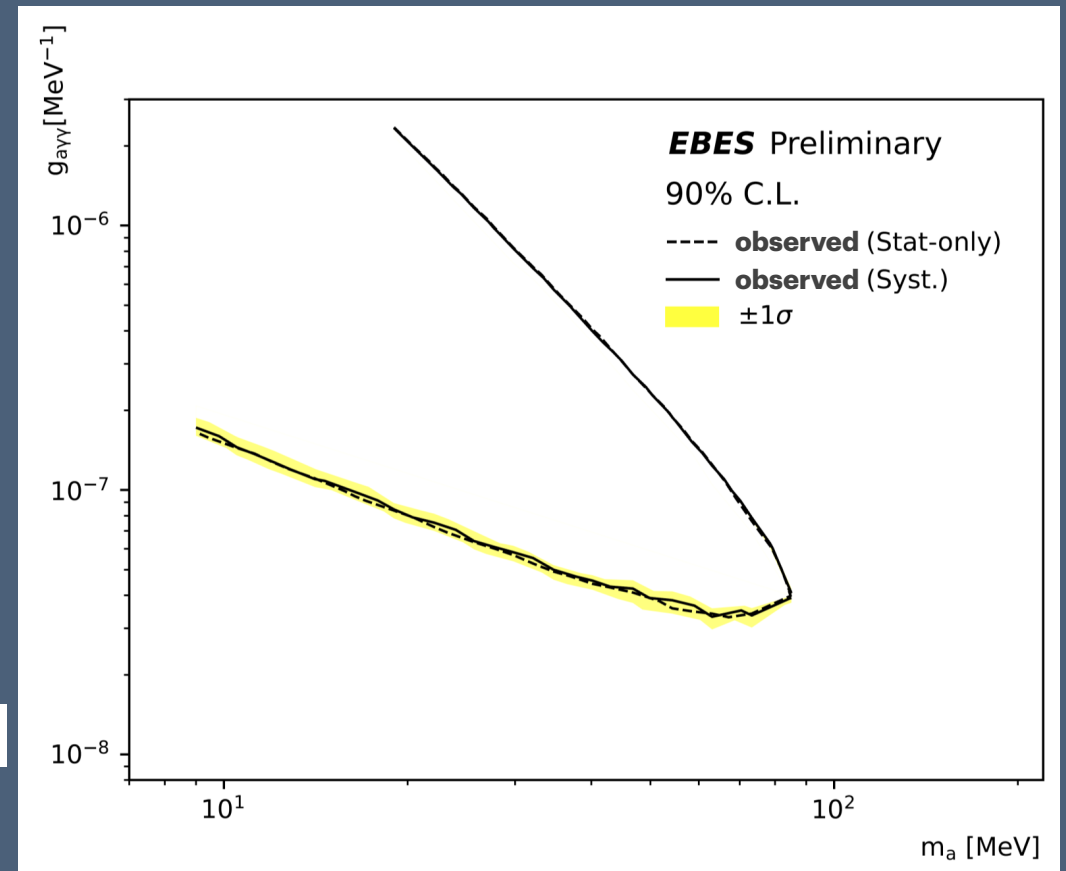
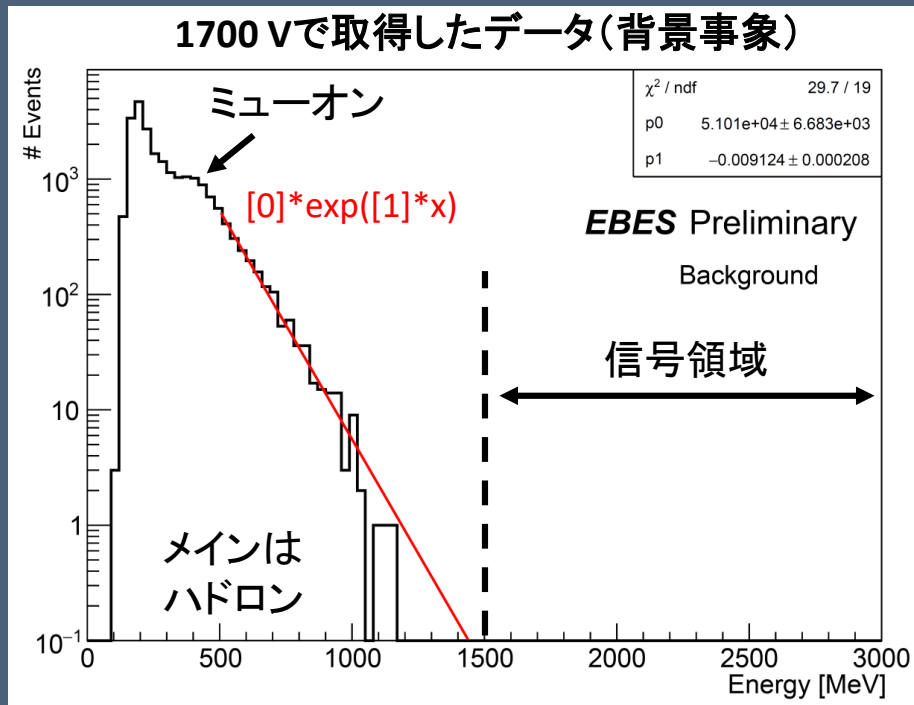

From T. Iizawa (19pT1-7)

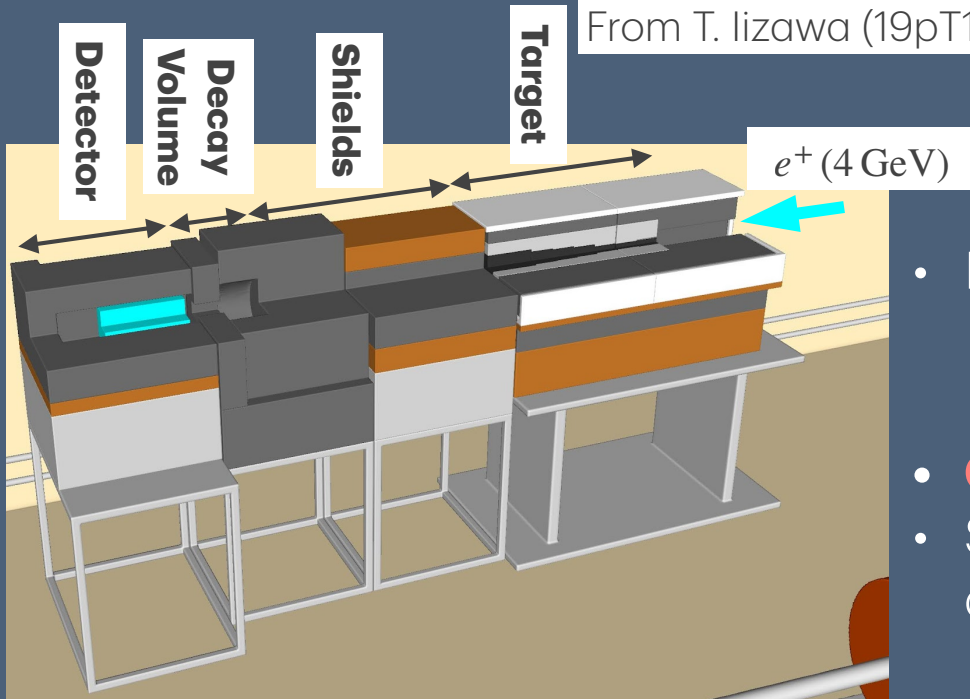

From T. Iizawa (19pT1-7)

- Results from just 3 hours of DAQ
 - Bunch charge $\sim 0.1 \text{ nC}$
 - **Collected 1.3×10^{14} positrons on target**
 - **One PbO cherenkov detector used**
- Set the ADC threshold high and searched in the background-free region

Upgrade Plan

Phase 1 (setup in this talk)

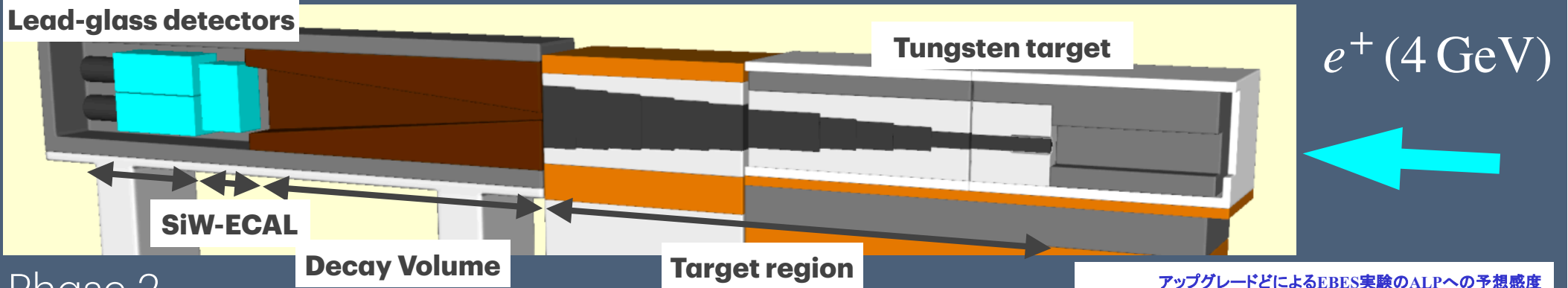

Phase 2



High granularity calorimeter

Phase 3

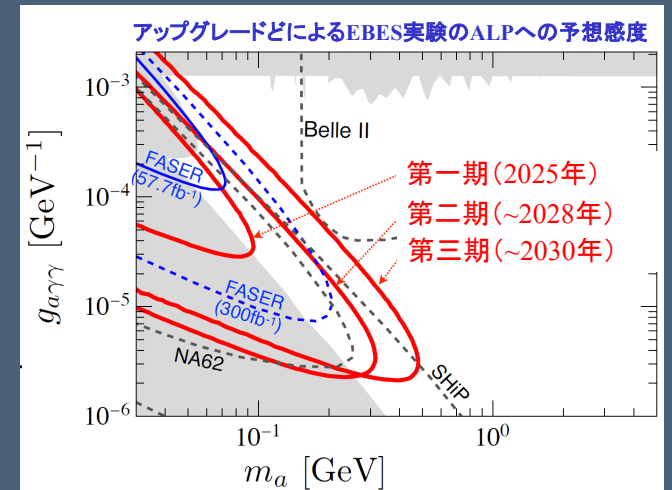
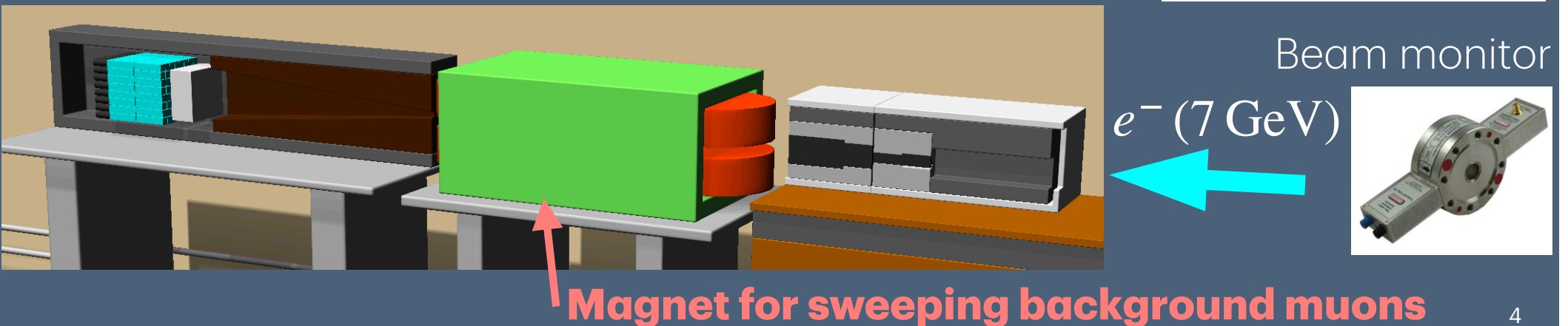

Phase-1 Setup ①

Taken during the setup construction in Sep. 2025

e^+/e^- beam

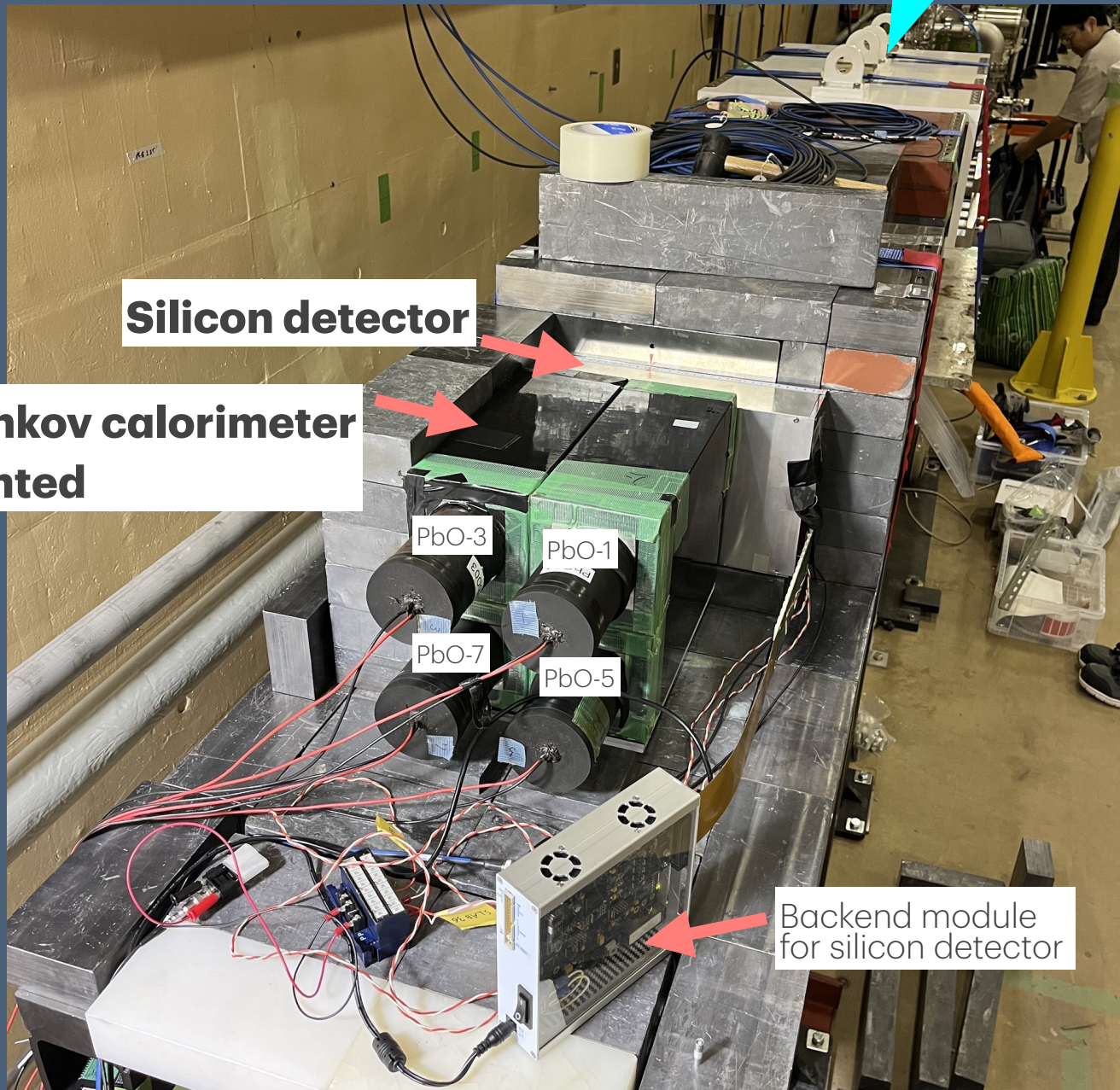

Silicon detector

PbO Cherenkov calorimeter
2x2 segmented

PbO-3

PbO-1

PbO-7

PbO-5

Backend module
for silicon detector

Phase-1 Setup ②

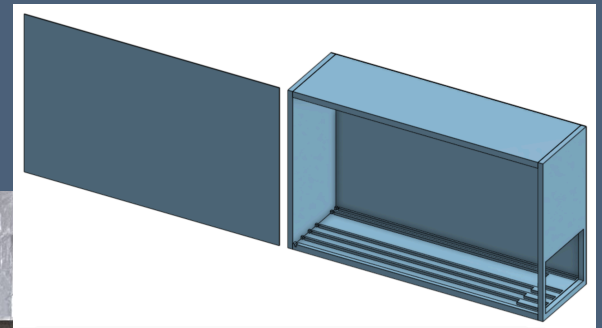

PbO Cherenkov calorimeter



Sensitive area $\sim 18 \times 18 \text{ cm}^2$

Pixel size $\sim 5 \times 5 \text{ mm}^2$

1024 pixels in total

Silicon detector

✖ 2-3 layers used

✖ Without absorber layers

- Main calorimeter is **PbO Cherenkov calorimeter**
 - Developed for the barrel electromagnetic calorimeter for VENUS at the KEK TRISTAN
 - **DF6 lead-grass block of $12 \times 11.6 \text{ cm}^2 \times 30 \text{ cm}$ read by a PMT**
 - Calibrated at PF-AR TBL (Test Beam Line) using electron beam in 2023
- Data were recorded using a 12-bit CAMAC-ADC and a 12-bit/3.2 GSPS waveform digitizer

Wavecatcher 波形

Wavecatcher 波形

タイミング調整した時のスクショをはっつけて、
うち、どこがCAMAC-ADCのwindowか示す
<- 電子銃起因のbkgを落とせるかもを期待

SLAB from SiW-ECAL for CALICE/ILD

- SiW-ECAL
 - 20-30 layers of **sandwich calorimeter with tungsten absorber**
 - **1 layer of SiW-ECAL = 1 SLAB + 1 absorber**
 - **Segmented silicon pads of $5 \times 5 \text{ mm}^2$**
 - PCB with ASICs embedded (SKIROC2A chip)
 - Jointly developed primarily by Japan, France, and Spain
- **Will be applied in EBES to identify signal 2γ**

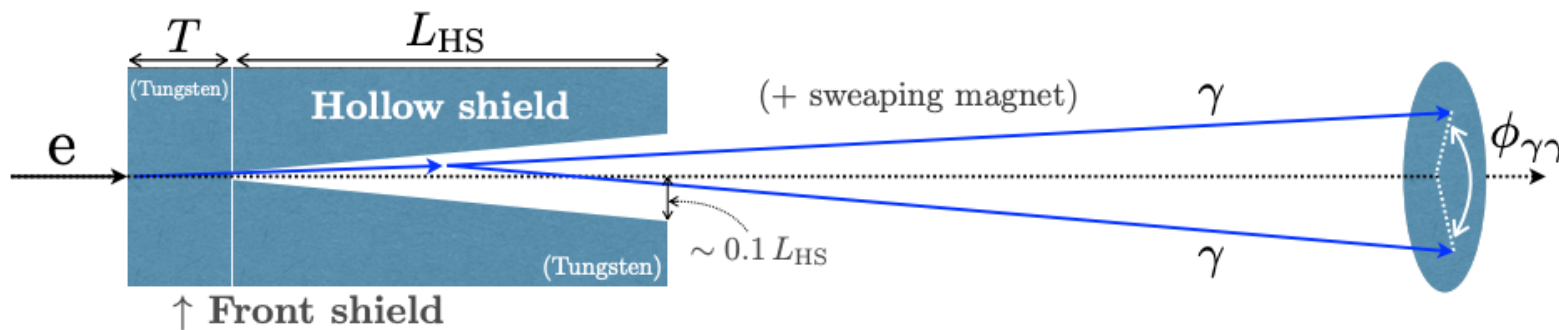
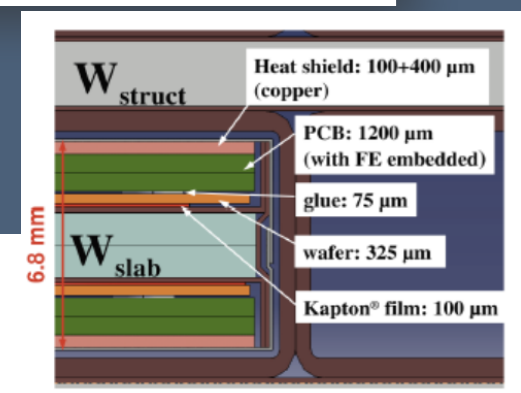
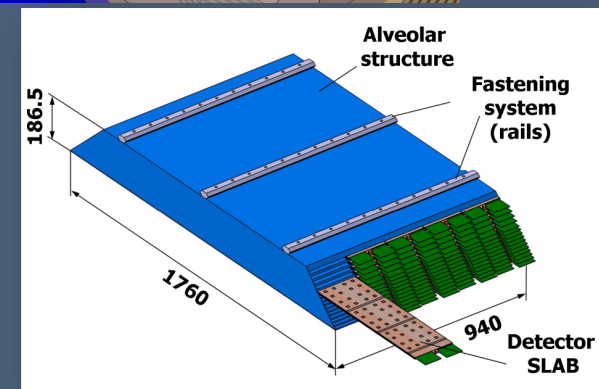
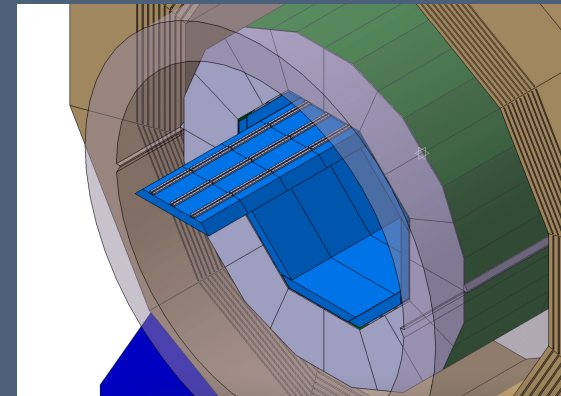

First Physics Run with the Phase 1 Setup

- **The first physics run** was conducted **with the phase 1 setup** from Oct. 2 to Nov. 5, 2025
- Acquired data
 - Main data
 - With **4 GeV Beam:** $344 \times 10^3 \text{nC}$ in total (**$\sim 16\times$ that of the pilot run**)
 - In the following analysis, using only 4% of the total data from a specific run as a control sample
 - With **7 GeV Beam:** $172 \times 10^3 \text{nC}$ in total
 - Calibration data
 - Pedestal run
 - HV scan
- ~~Unfortunately, the silicon detectors were not fully operational due to problems with the electronics (もうちょっとシリコン不安にさせない書き方)~~

Overview of the Electronics

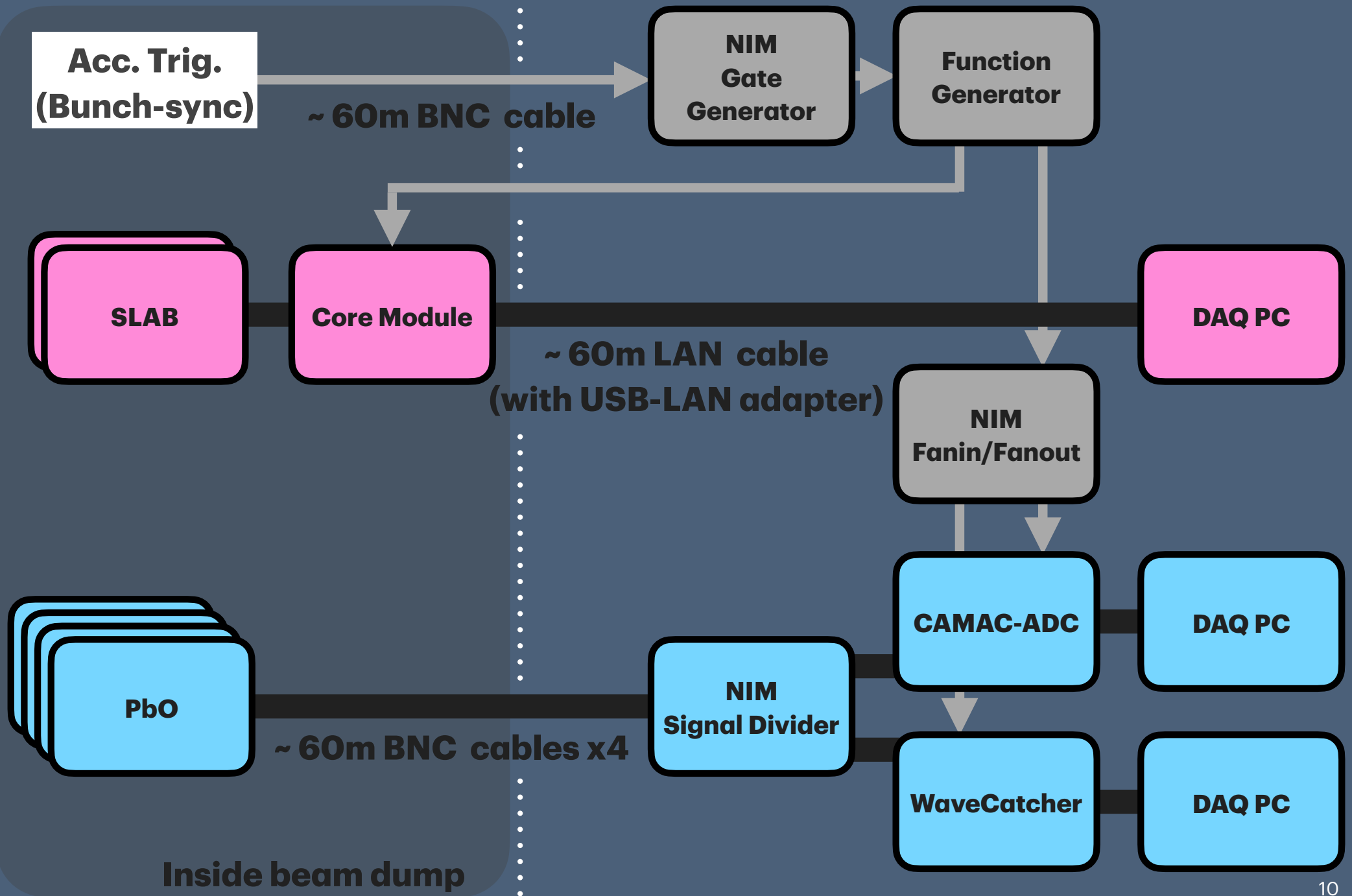

Data Synchronization

- Data to be synchronized
 - PbO calorimeter acquired with CAMAC-ADC
 - PbO calorimeter acquired with WaveCatcher
 - Silicon detector
 - Loss monitor and BPM (Beam Position Monitor)
 - Used to detect beam loss and reduce beam-induced background
- All data are **acquired using the accelerator trigger**, with independent DAQ systems
- Synchronization is performed offline
- Due to the low trigger rate of $\sim O(10\text{Hz})$, **synchronization is timestamp-based**
 - Loss monitor and BPM share a common shot ID via the Linac event timing system
 - Synchronization among PbO (CAMAC-ADC), Loss monitor, BPM is already done

Hit Map of Silicon Detector (4 GeV)

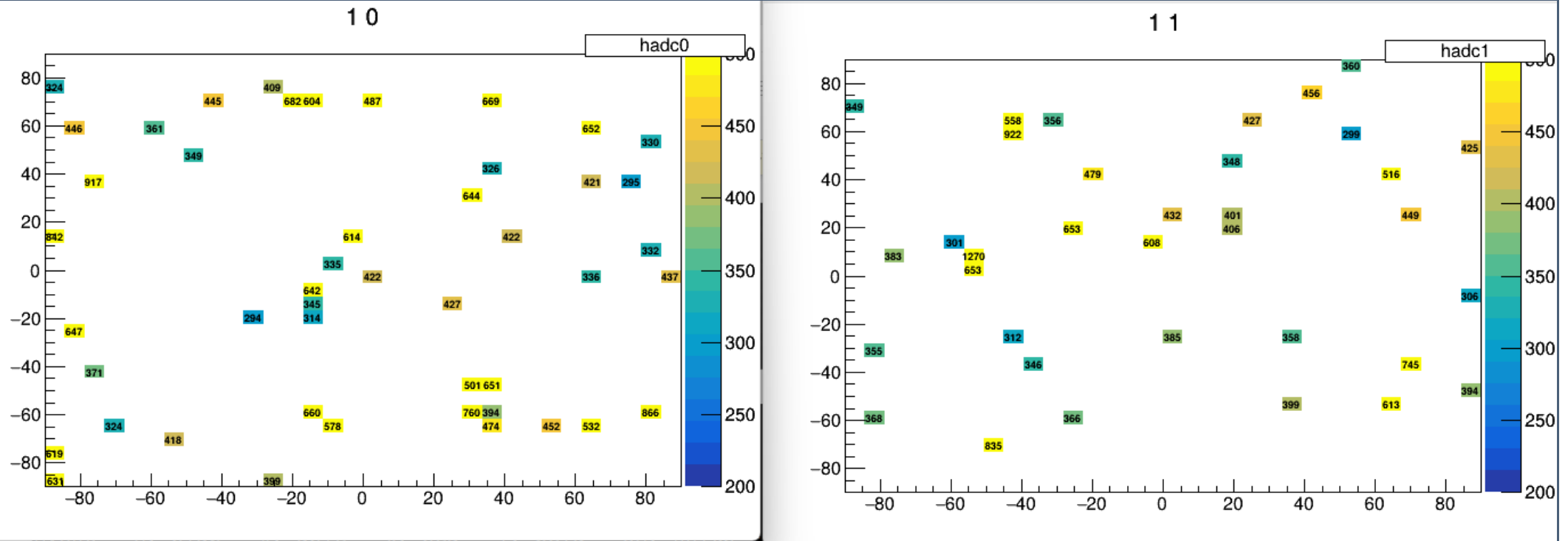

- With the **4 GeV beam**, the **backgrounds composition is complex** (still under study)

Hit Map of Silicon Detector (7 GeV)

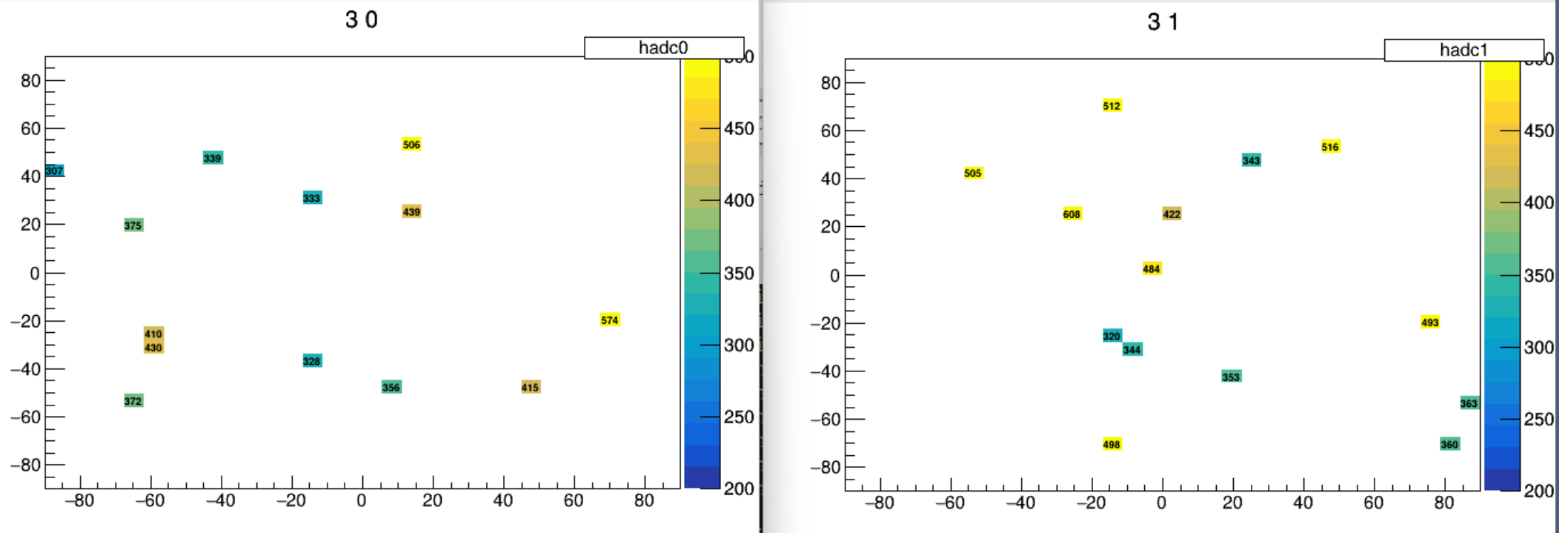

- With the **7 GeV beam**, the **backgrounds is dominated by muons**
- Tracking with only 2 layers seems difficult (analysis ongoing)
 - Just getting an approximate muon flux would be helpful

Radiation Damage to Silicon Detectors

- **An increase in dark current and the emergence of hot pixels were observed** during the Sep.-Dec. Linac operation
 - Hot pixels correspond to **~1-2% of the active area** (at the threshold ~ 0.5 MIP)
- **Mitigation of radiation damage is essential for long-term operation**
 - The damage is assumed to be dominated by neutrons
- Dedicated small-pixel sensors have been installed for radiation monitoring from Jan. 2025
 - The silicon detectors have been uninstalled
- The sensors are enclosed with **neutron shielding (boron-loaded polyethylene, BPE)**
 - Up to an order-of-magnitude reduction in damage is expected
- I-V characteristics have been regularly monitored since the Jan. during the Linac operation period

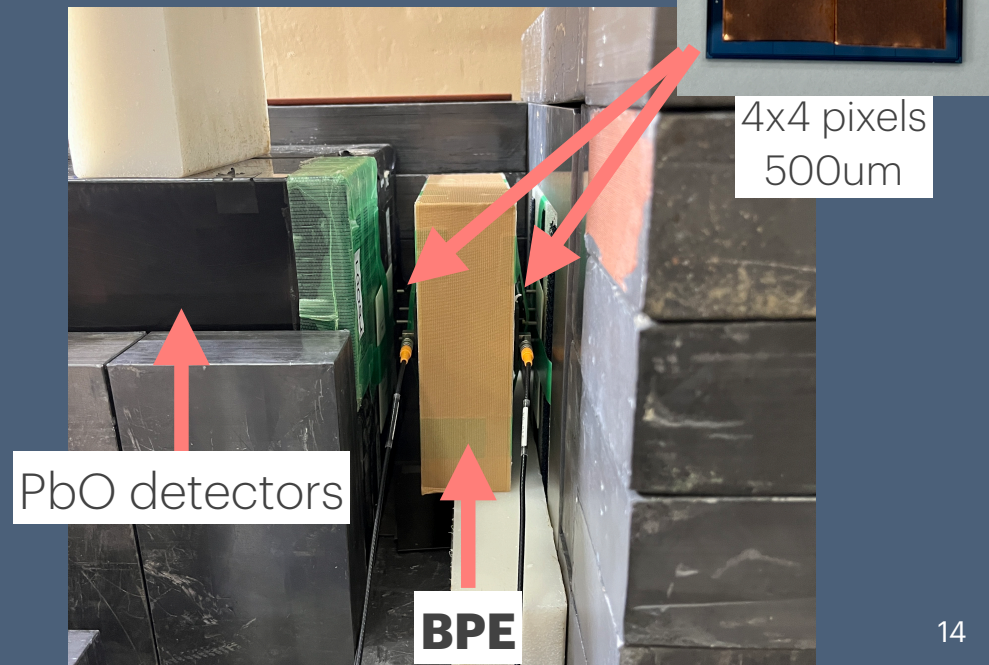
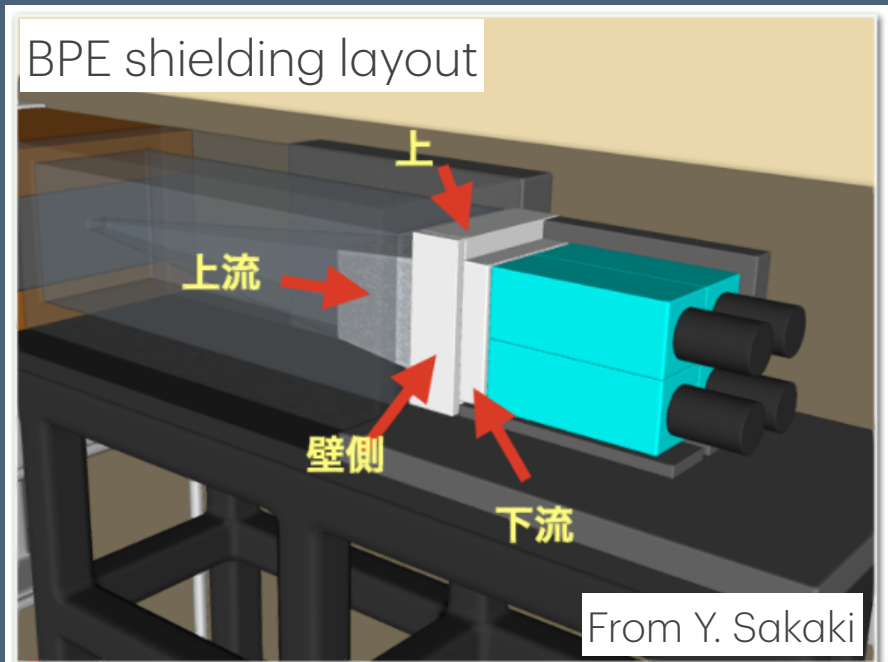

BPE Layout

- **BPE shielding can reduce neutron flux by up to an order of magnitude**
 - A thickness of a few centimeters is sufficient
 - It is **important to shield the object from all directions** (4π coverage)

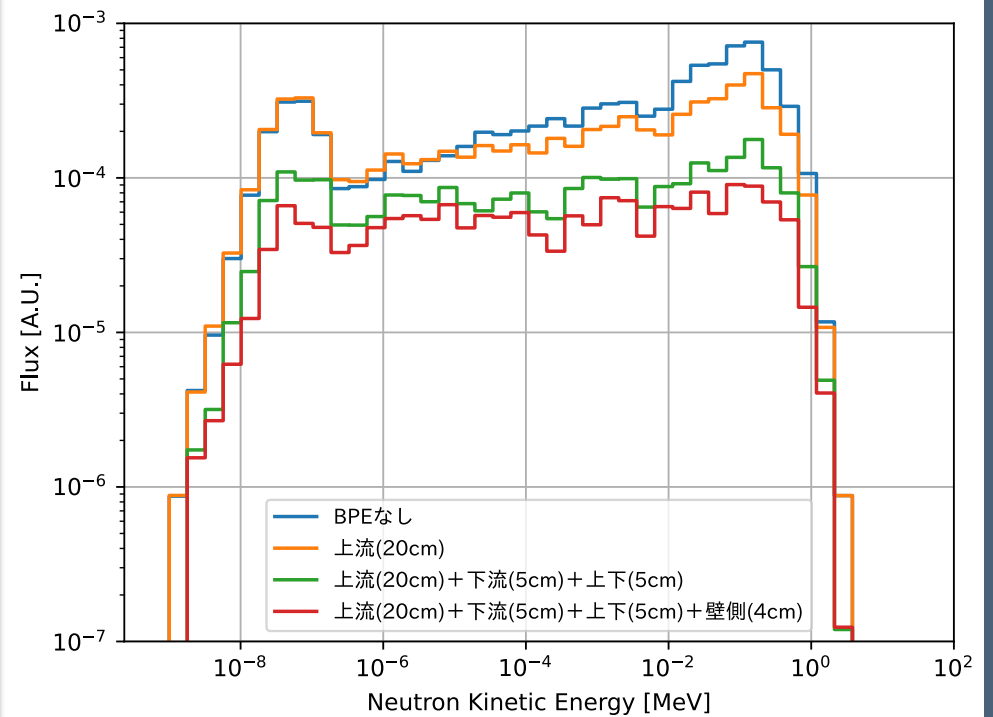
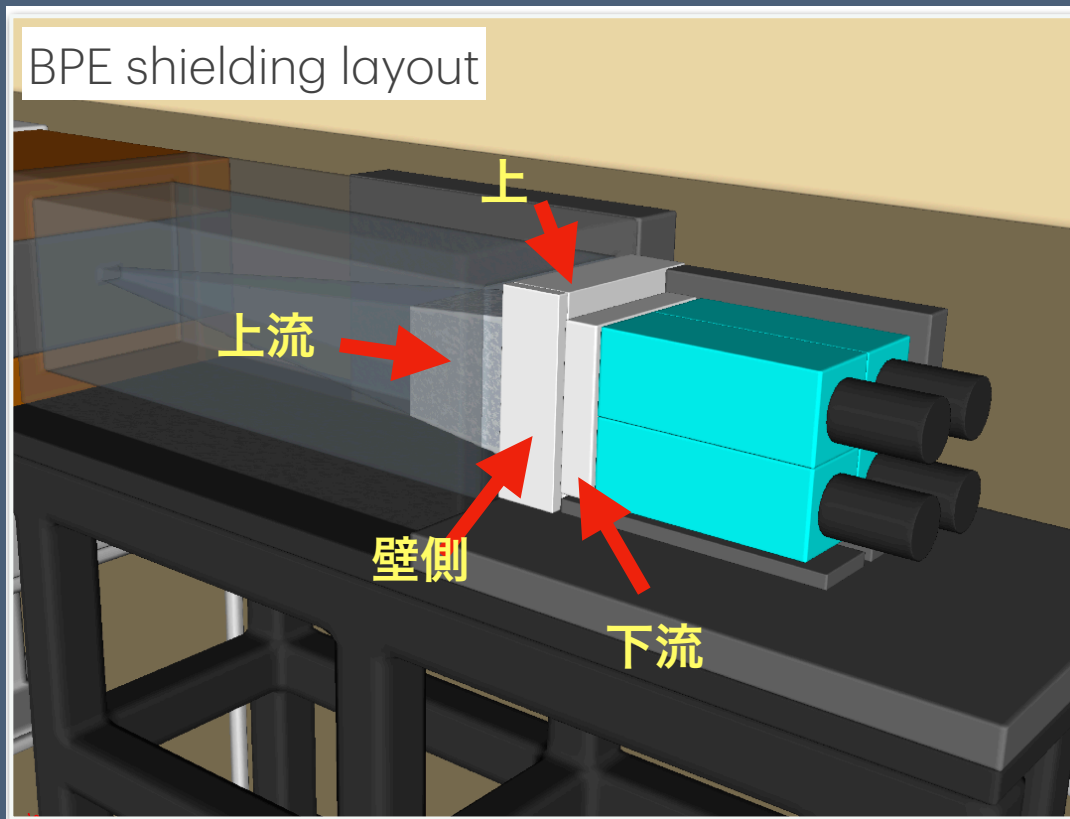

From Y. Sakaki

Beam Exposure and Dark Current

- The effectiveness of the BPE shielding and the expected lifetime of the silicon detectors are being evaluated
-

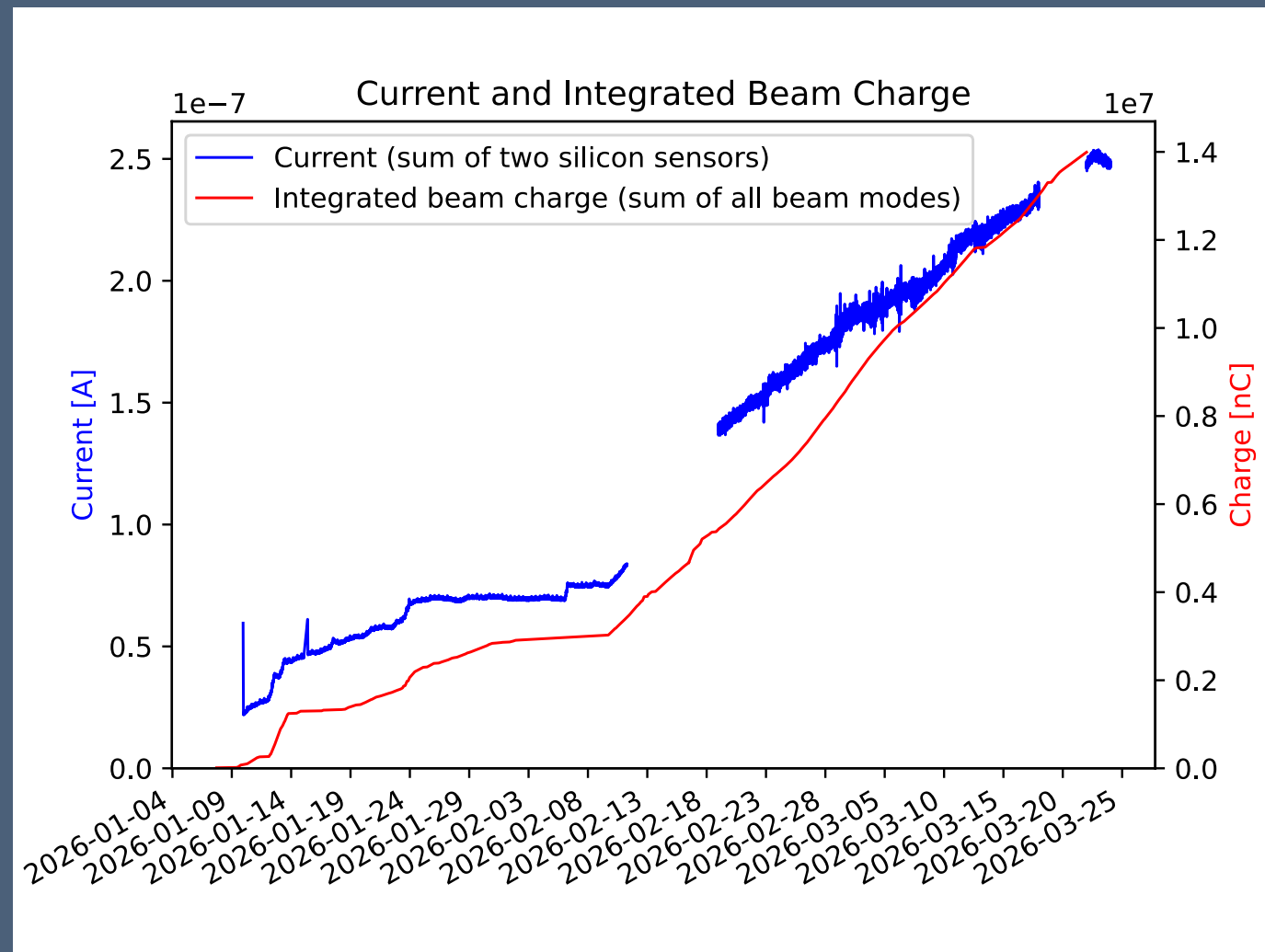

Plan for Understanding Backgrounds

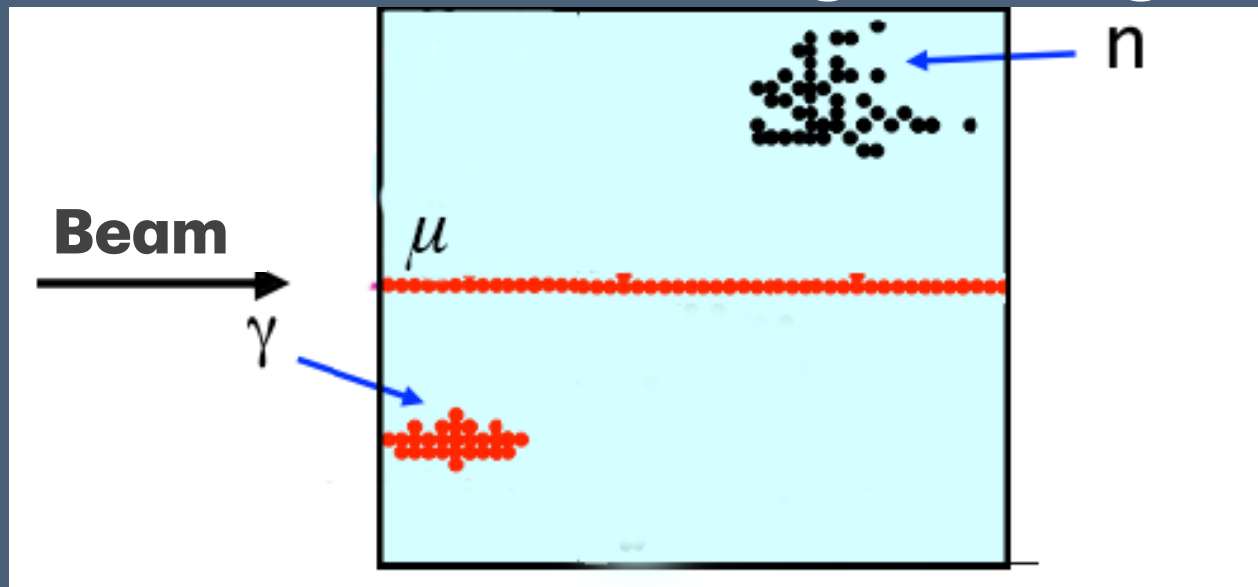

- **Understand the background is the top priority** by comparing data with and without absorbers
- **Charged particles:** electrons and muons are distinguishable
 - Charged pions are not expected to come
- **Gamma rays:** install the absorbers and check the incident direction
- **Low energy (~ 10 MeV) neutrons:** will likely convert to gamma rays with absorbers
 - Scattering from the wall side may be observed, even without absorbers
- **High energy neutrons:** difficult to identify
 - Placing silicon layers behind lead-glass detectors might help identify them

Conclusions

- **EBES experiment is beam dump experiment searching ALP** at KEK LINAC SY3
- **The first physics run with the phase 1 setup was conducted** from October to November 2025
 - A method to suppress high-energy background using the Linac loss monitor and BPM has been established
 - Background distributions have been derived from control samples
- **Limits will be set** using simulation studies **in the future**
 - The segmented structure of the calorimeter, unlike in the pilot run, will also be utilized
- (シリコンにフォーカスして書き直す)