

ITN (ILC technology Network) activity at KEK

Hiroshi Sakai (on behalf of IDT members in Japan)

Innovation Center for Applied Superconducting Accelerators (iCASA), Accelerator Laboratory

High Energy Accelerator Research Organization (KEK)

I only talk about **ILC Accelerator parts and progress.**

Contents :

- A) ILC Overview & ILC Technology Network (ITN)
- B) ILC activities until JFY2025 (mainly Japanese activities on MEXT-ATD)
- C) Summary and Future plan (JFY2026 ~)

20 min (talk)

2026.Apr.28 IDT-WG2 meeting

24 pages

(A)



Contents :

A) Overview & ILC Technology Network (ITN)

B) ILC activities in JFY2025 (mainly Japanese activities on MEXT-ATD)

C) Summary and Future plan (JFY2026 ~)

ILC and the Accelerator Technology

From 2023, key technologies of WPPs are developed under ILC Technology Network(ITN)

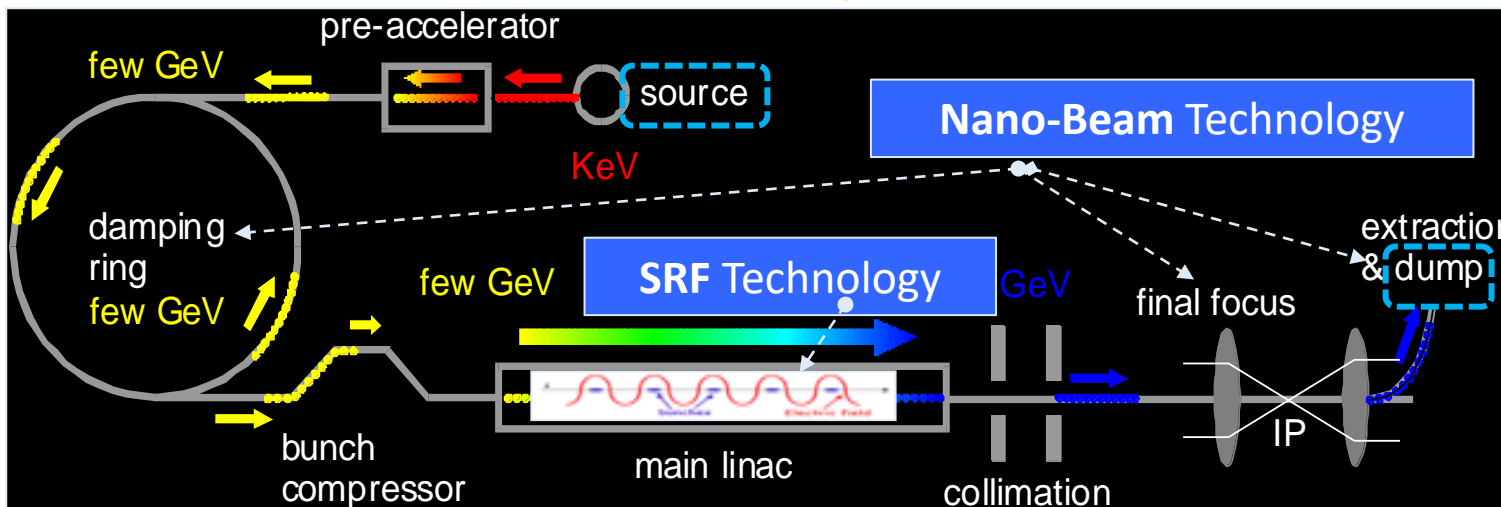
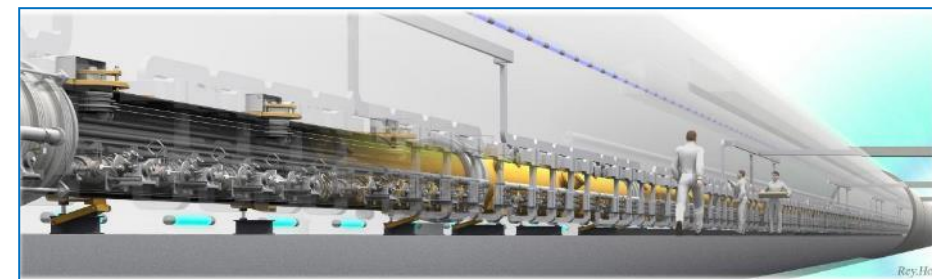
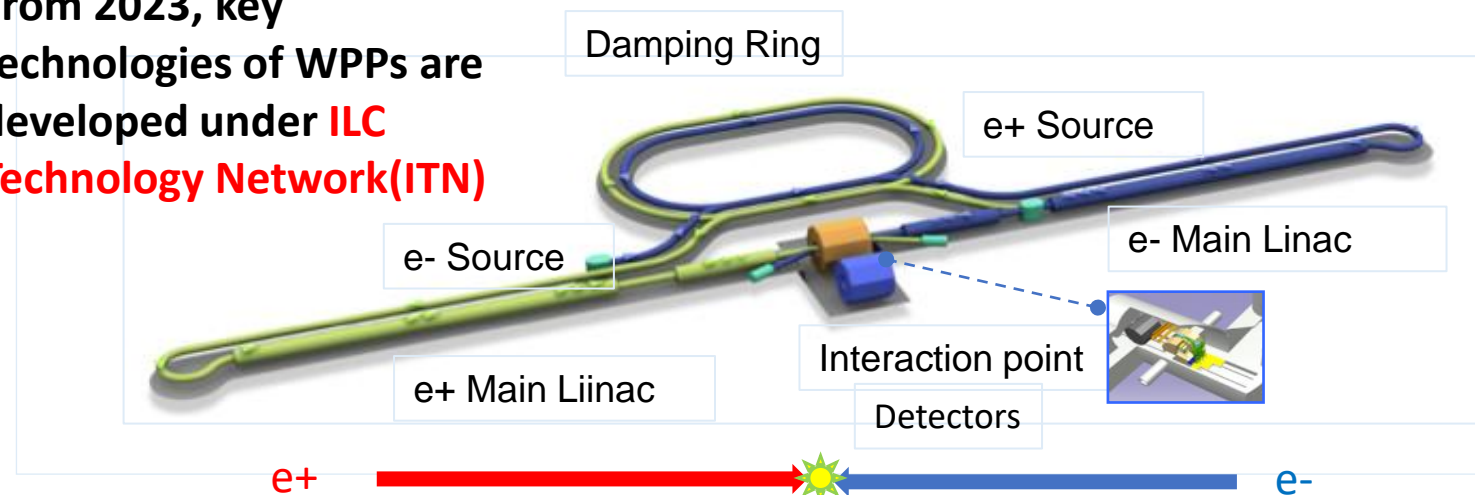

- (ILC key technologies) done under ITN
1. SRF cavities of 9000 numbers
 2. Nanobeam production and stability.
 3. Huge electron and positrons production

Recently LCF@CERN also follow SRF technology of ILC.

Parameters	Value
Beam Energy	125 + 125 GeV
Luminosity	1.35 / 2.7 x 10 ³⁴ cm ² /s
Beam rep. rate	5 Hz
Pulse duration	0.73 / 0.961 ms
# bunch / pulse	1312 / 2625
Beam Current	5.8 / 8.8 mA
Beam size (y) at FF	7.7 nm
SRF Field gradient	< 31.5 > MV/m (+/-20%) Q ₀ = 1x10 ¹⁰
#SRF 9-cell cavities (CM)	~ 8,000 (~ 900)
AC-plug Power	111 / 138 MW

IDT Scope for ILC Realization (in 2023)



-success oriented and assuming no major incident-

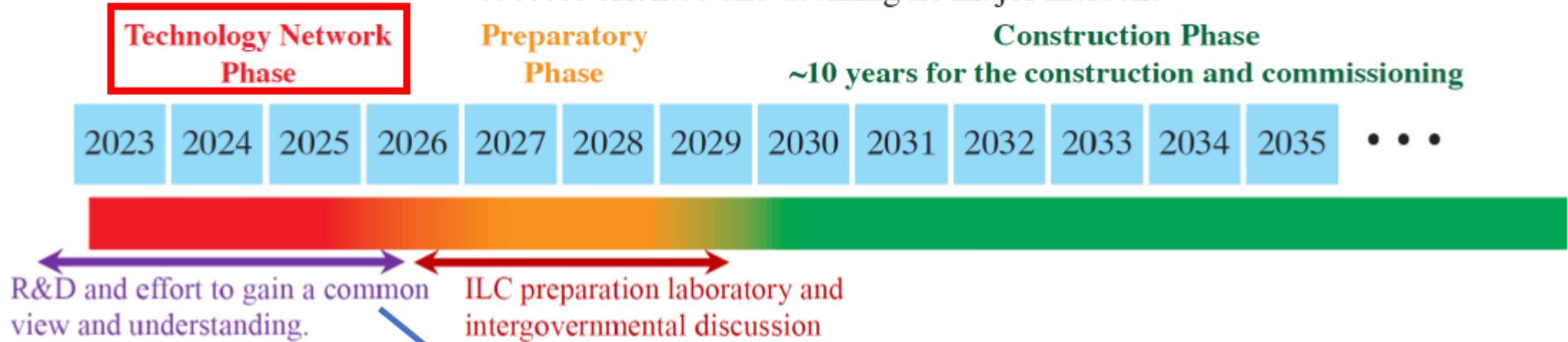

2021 May

Technical Preparation and Work Packages (WPs) during ILC Pre-lab

Work Packages (WPs) for ILC Pre-Lab

<http://doi.org/10.5281/zenodo.4742018>

2022 June

Time-critical WPs for the ILC construction

WP-Primes for Time Critical

https://agenda.linearcollider.org/event/9649/attachments/38003/60567/Time-Critical_WPsV8b.pdf

ILC Technology Network (ITN)

-- global collaboration program---

- **Acc. R&Ds** focusing on
 - SRF
 - e- & e+ Sources
 - Nano-beam

KEK obtained a budget for these R&Ds and started the activity from 2023.

ILC Technology Network & KEK's efforts



Details are explained as follows in “(B) ILC activities until JFY2025 (in Japan)”

KEK started the activity from April, 2023.

令和5年度

将来加速器の性能向上に向けた重要要素技術開発
 (先端加速器共通基盤技術研究開発費補助金)

公募要領

~6.6Oku-yen/year x5 years (~4.7M\$/year)
 For 3 critical components development (**SRF, Source & nanobeam**)

MEXT development of key element technologies to improve the performance of future accelerators program
 文科省補助金 将来加速器の性能向上に向けた重要要素技術開発
advanced Accelerator element Technology Development (MEXT-ATD) funded by MEXT

文部科学省 研究振興局

令和5年2月

SRF

e-, e+ Sources

Nano-Beam

WPP	1	Cavity production
WPP	2	CM design
WPP	3	Crab cavity
WPP	4	E- source
WPP	6	Undulator target
WPP	7	Undulator focusing
WPP	8	E-driven target
WPP	9	E-driven focusing
WPP	10	E-driven capture
WPP	11	Target replacement
WPP	12	DR System design
WPP	14	DR Injection/extraction
WPP	15	Final focus
WPP	16	Final doublet
WPP	17	Main dump

Collaboration with Europe, Korea,

Experiences at SuperKEKB

ATF collaboration

We held Advisory board meeting for MEXT-ATD every half year to check our progress.

- In JFY2025, & 5th meeting held 2024/10 online
- & 6th meeting was held on 2026/Mar./3-5 in person in KEK

(B)



Contents :

A) Overview & ILC Technology Network (ITN)

B) ILC activities in JFY2025 (mainly Japanese activities on MEXT-ATD)

1) Introduction of MEXT-ATD

2) R&D of SRF, Positron, Nanobeam

C) Summary and Future plan (JFY2026 ~)

introduction of MEXT-ATD program



MEXT-ATD activities are broadly classified into (1) nanobeam, (2) superconducting radio-frequency (SRF), and (3) positron .

Present our goals

	Goals of MEXT-ATD (2023-2027)
Nanobeam	Demonstration of long-term stability in ATF
SRF	Evaluation of one cryomodule (CM)(including fabrication of CM components such as cavity and couplers)
Positron	Evaluation of target, flux concentrator (FC) and cavity

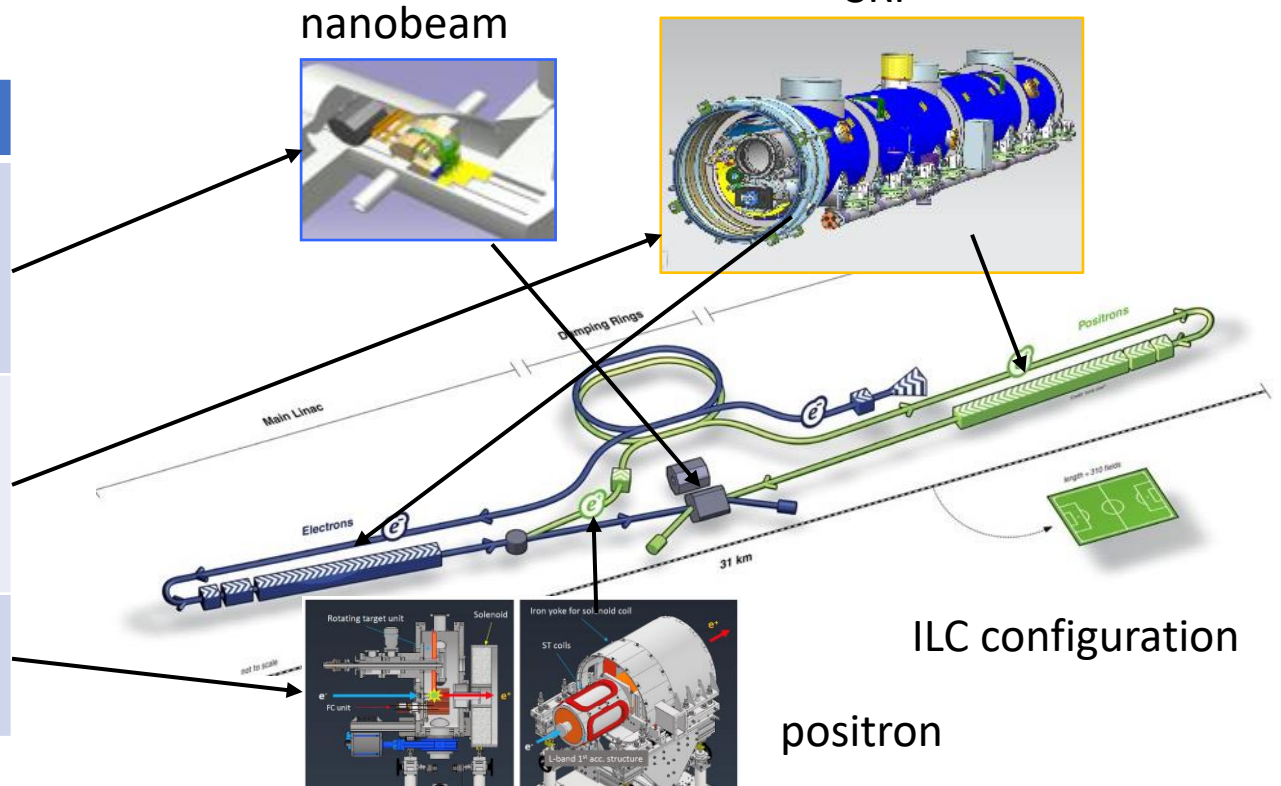

We were able to make progress as originally planned. Although we anticipate that the next fiscal year and beyond may be more challenging, depending on future price trends and so on, we will strive to achieve our goals.

(Re)scheduled plan from FY2026

Details of change will be shown in SRF session



	2023	2024	2025	2026	2027
Nanobeam	<ul style="list-style-type: none"> ✓ Procurement of High-Order magnets ✓ Upgrade of beam operation and equipment 	<ul style="list-style-type: none"> ✓ Reduction of wake field and higher order aberration ✓ Upgrade of beam operation and equipment 	<ul style="list-style-type: none"> ● Precise measurement of nanobeam, ✓ Upgrade of beam operation and equipment 	<ul style="list-style-type: none"> ● Improvement of beam turning method (incl. AI) ● Vertical beam size on IP <37nm 	<ul style="list-style-type: none"> ● Improvement of beam turning method (incl. AI) ● Long-term stabilization of nanobeam (for a few days)
Superconducting RF cavities	<ul style="list-style-type: none"> ● Nb Material Procurement ● Cavity Development ● High-Pressure Gas action 	<ul style="list-style-type: none"> ● Cavity development(0) <ul style="list-style-type: none"> ● Single cell (6) ● Vertical test (single cell) ● High-Pressure Gas action (continue) 	<ul style="list-style-type: none"> ● Cavity development (4+2+2) From abroad (2) ● Vertical test (35MV/m, 1E10) ● High-Pressure Gas action (continue) 	<ul style="list-style-type: none"> ● Cavity development (35MV/m, 1E10) ● Welding Helium tank ● Further High Performance ● High-Pressure Gas action (continue) 	<ul style="list-style-type: none"> ● Further High Performance ● High-Pressure Gas action (continue)
SRF Cryomodule	<ul style="list-style-type: none"> ● Drawing module and each components ● High-Pressure Gas action 	<ul style="list-style-type: none"> ● Coupler fabrication (4) ● Tuner prototype ● magnetic shield prototype ● SC magnet fabrication ● Fabrication CM 	<ul style="list-style-type: none"> ● Coupler fabrication (4) ● Tuner fabrication (4) ● magnetic shield fabrication (2) ● SC magnet fabrication (Cont') ● Fabrication CM 	<ul style="list-style-type: none"> ● Coupler fabrication (8) ● Tuner fabrication (4) ● magnetic shield fabrication (6) ● Fabrication CM (Cont') ● String assembly ● High-Pressure Gas 	<ul style="list-style-type: none"> ● Coupler power test ● String assembly ● Construction CM ● High-Pressure Gas (inspection) ● Performance test of CM ● (31.5MV/m, 1E10)
Positron source	<ul style="list-style-type: none"> ● Preparation test bench ● Design ● W-Cu joint test 	<ul style="list-style-type: none"> ● Development W target 	<ul style="list-style-type: none"> ● Development of rotating target ● Fabrication of FC 	<ul style="list-style-type: none"> ● Development of accelerating structure 	<ul style="list-style-type: none"> ● Total high power test

Due to the cavity fabrication under the HPGS law and power coupler fabrication trouble and increasing the price since 2022, we plan to reschedule as shown above. Our new plan is the completion of cryomodule. We plan to conduct high power test in the additional two years after finishing MEXT-ATD program.

SRF development

We also continue cavity fabrication & test some ancillaries in JFY2025



WPP-1: cavity surface treatment

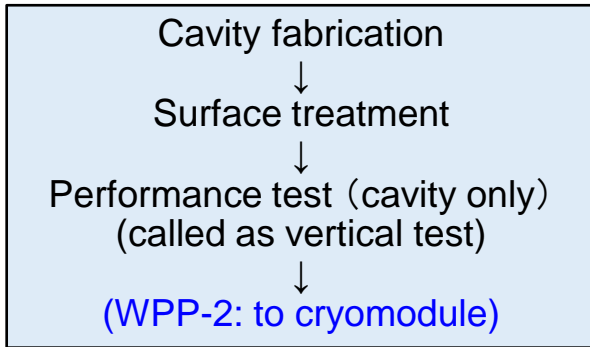

WPP-2: Cryomodule test

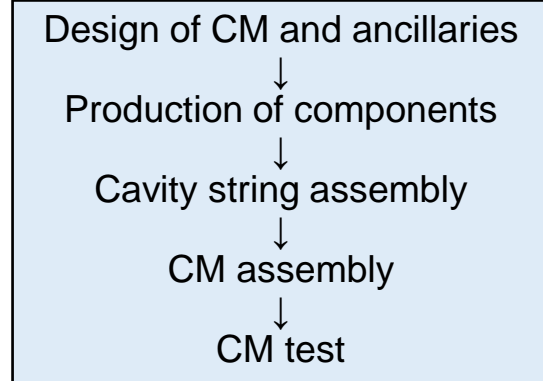

- ◆ One CM design by global collaboration, production and test in Japan
- ◆ Cavity performance for vertical test $E_{acc} = <35.0 \text{ MV/m} >$, $Q_0 = 1.0 \times 10^{10}$
- ◆ 8 cavities produced/evaluated in WPP-1 to be assembled, including some cavities from overseas. Globally common design applicable to high pressure gas safety (HPGS) regulation **under ITN collaboration (world wide)**
- ◆ Ancillaries production/evaluation:
 - ◆ input power coupler, frequency tuner, SCQ+cold BPM, magnetic shield, advanced clean work
- ◆ After assemble all parts to one cryomodule, we test high power test
- ◆ Cavity performance in cryomodule: $E_{acc} = <31.5 \text{ MV/m} >$, $Q_0 = 1.0 \times 10^{10}$

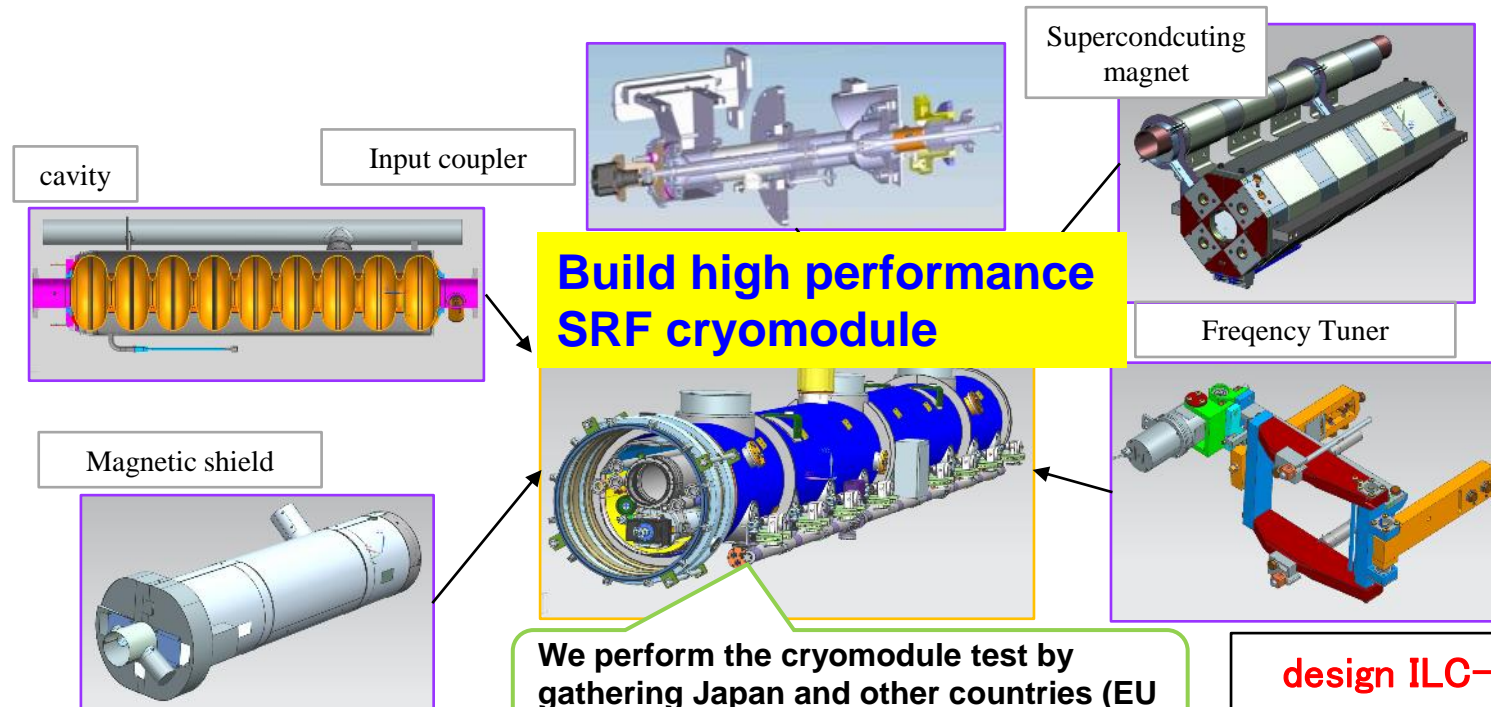

We perform the cryomodule test by gathering Japan and other countries (EU and so on) **(under ITN collaboration)**

design ILC-CM under ITN

(FY2025) (1)WPP1: Results of surface treatment by 2-step baking

Based on the results of past R&D, we chose **2-step baking** for this project.
VT for six 1-cell cavities was successfully done, going to 9-cell cavities in KEK.

(FY2025) All 6 cavities passed the spec

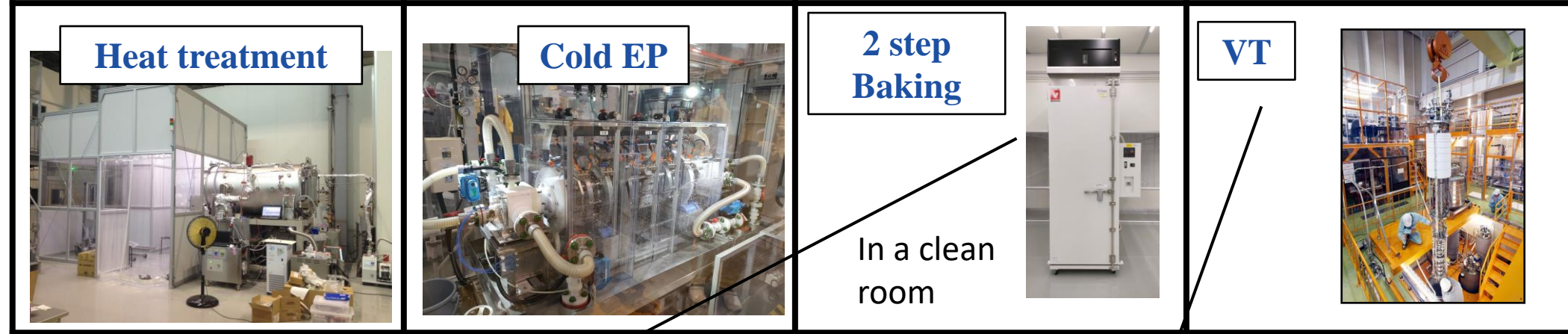
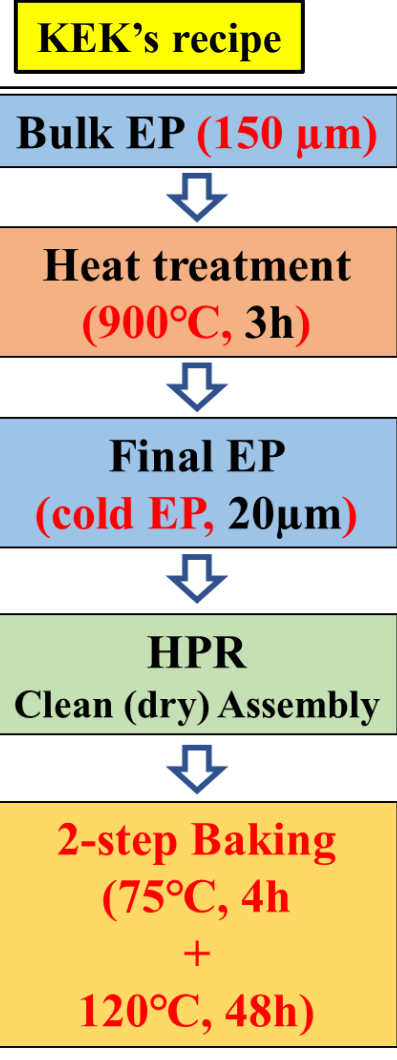

Kensei Umemori/
Ryo Katayama

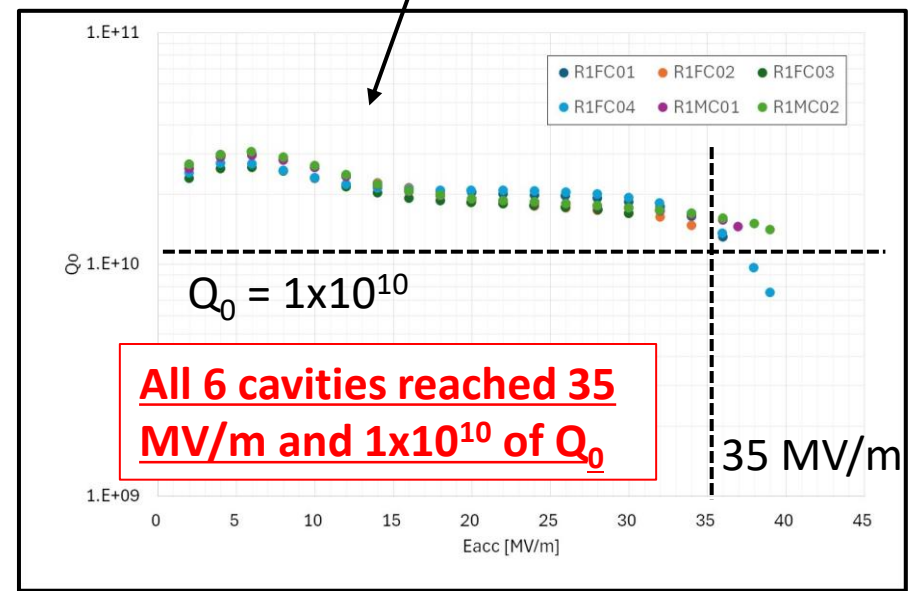
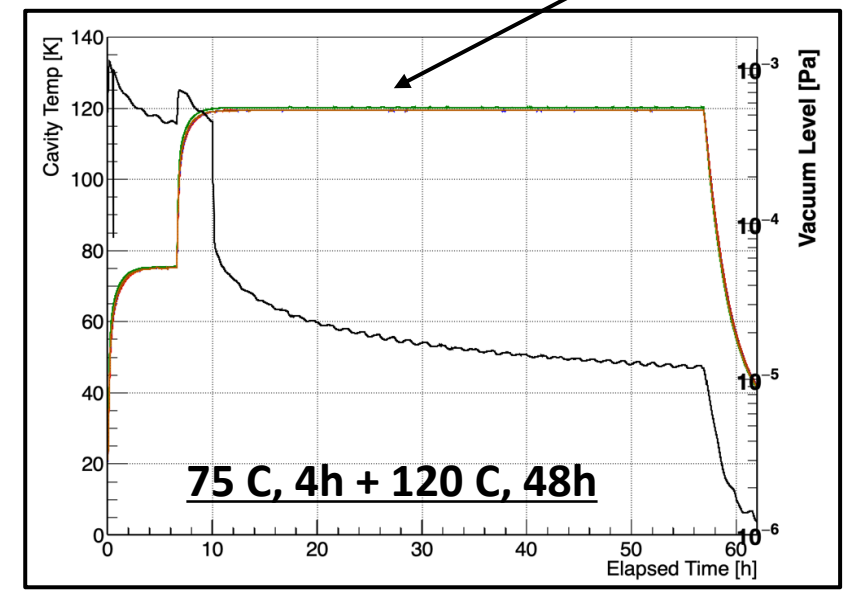

(FY2025) (1)WPP1: Progress of Cavity production at CFF/oversea



FG Nb

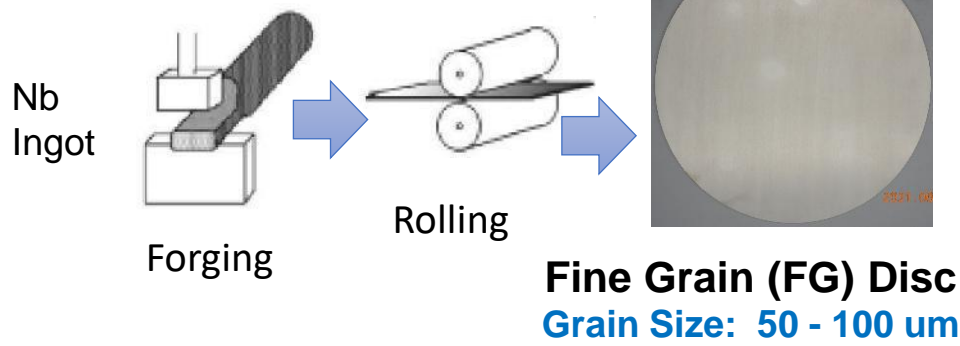

MG Nb

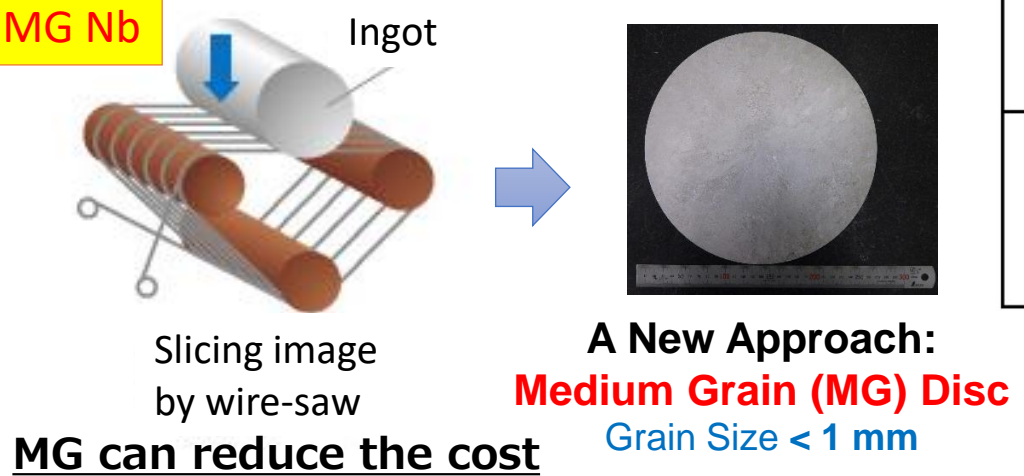

The last few year one-cell MG Nb cavity reached more than 35 MV/m.

The world's first MG cavity!

Six 1-cell cavities produced

Five 9-cell cavity produced

R1FC01 	R1FC03 	FC01 (completed) 	MC01 (completed)
R1FC02 	R1FC04 	FC02 (completed) 	MC02 Under production
R1MC01 	R1MC02 	FC03 Under production 	MC03 Under production ↓ Change FC05
		FC04 Under production	
		FR01, 02 Under production	

These cavities are made by RI!
(at the first time for KEK)

Categories related to HPGS

Takayuki Saeki/Takeshi Dohmae/Kensei Umemori

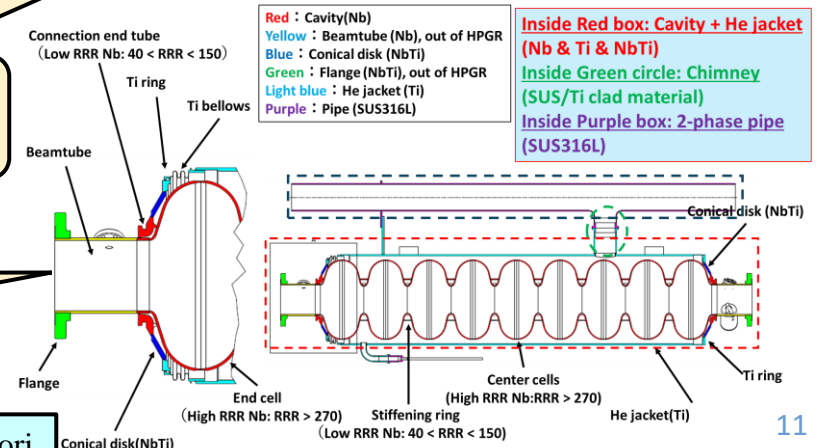

(Results of FY2025)

- **World's first MG 9cell cavity was fabricated.**
- **2 oversea 9-cell cavities were fabricated.**
- **Apply High Pressure Gas Safety regulation (HPGS) of KEK cavity.**

(FY2025) (2)WPP2: Ancillaries

- We saw the bad transmission. **Unexpectedly big RF loss observed in low power test!**
- Production another four sets of power couplers stopped and will make new 8 couplers.

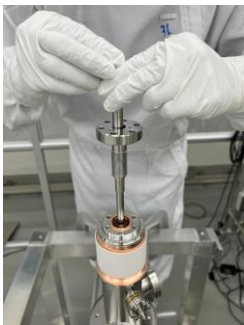

- **Cold test for each component under progress**
- **Procurement of real tuners under progress**
- Some simulation works under progress

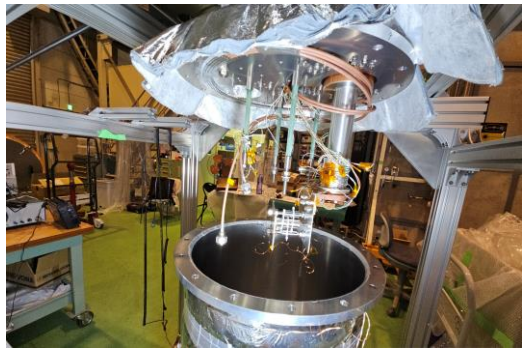
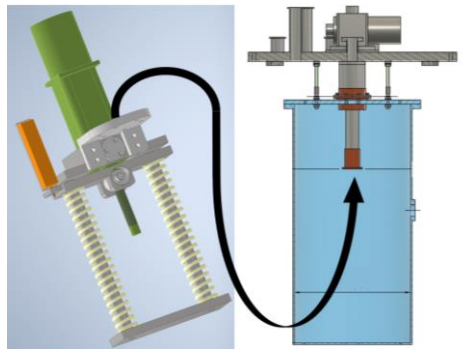

- Prototype magnetic shield was manufactured and delivered.
- Performance test of the prototype magnetic shield was completed.
- (After a minor design change) One real magnetic shield was delivered.

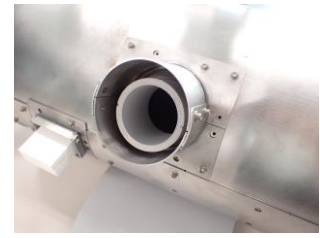

- Real magnet under production to be completed in this FY
- **Test cryostat produced and cold test was conducted.**
- Simulation for leak field under progress

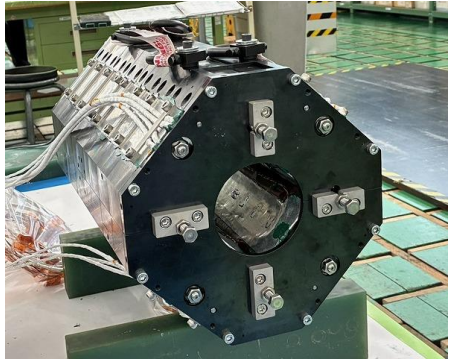

(FY2025) (2)WPP2: Progress of Cryomodule design

- ILC “Type B” CM chosen (eight cavities + one SC magnet/BPM)
- Single thermal shield @40K (5K dropped)
- Tuner access available
- 3D model completed
- Heat load simulation done (dynamic under progress)
- Waveguide support frame designed
- Total cost for contract under estimation

Specifications

Type	B
Thermal shield	Single
Vacuum vessel length	12,652 m
Vacuum vessel diameter	OD965mm, ID946mm
Coupler pitch distance	1326.7 mm
Cavity length	1247.4 mm

3D model of CM with waveguide system

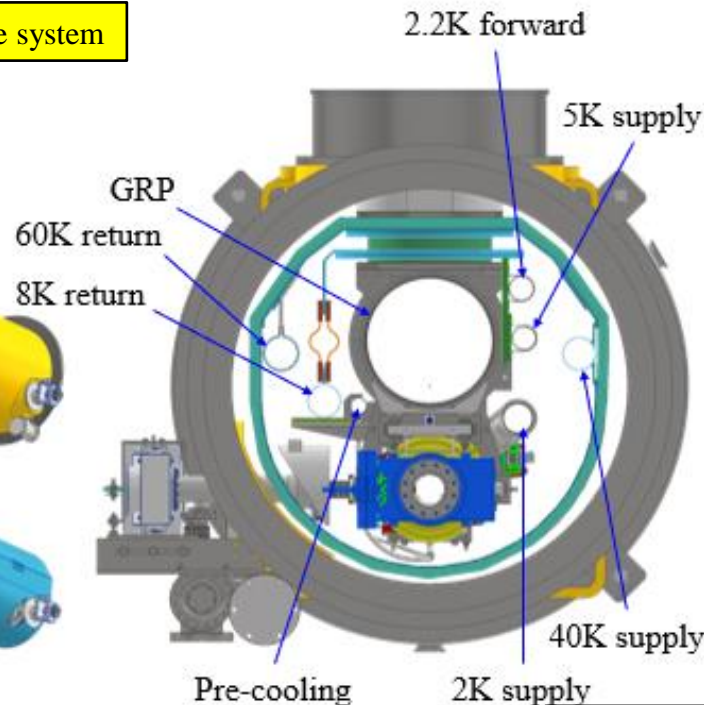
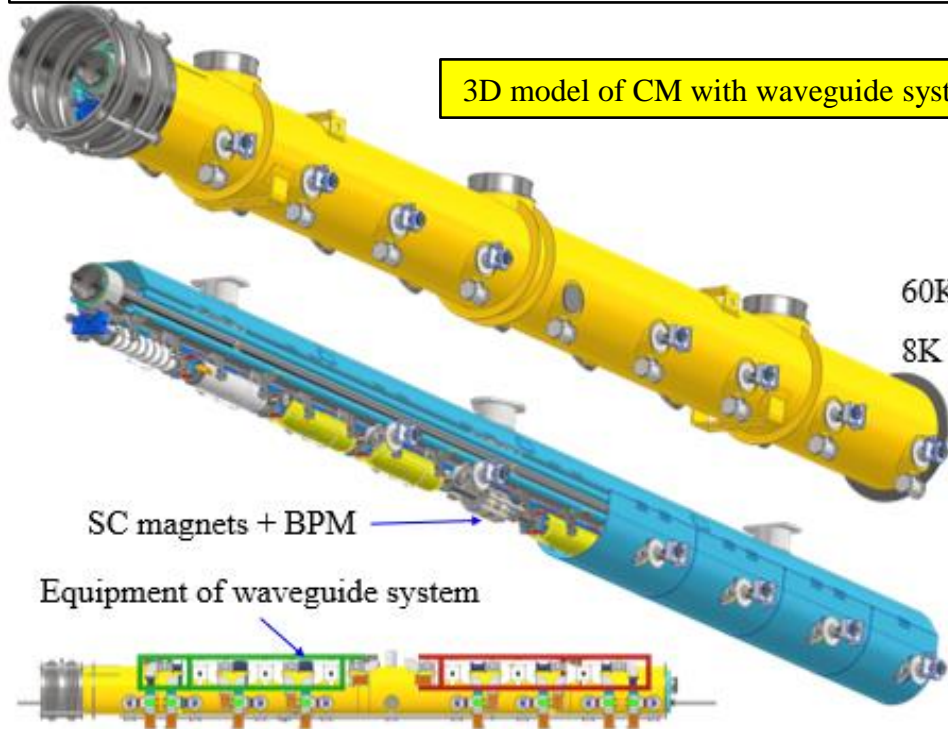

Thermal analysis for 40K shield

C: Steady-State Thermal
Temperature 3
Type: Temperature
Unit: K
Time: 1 s

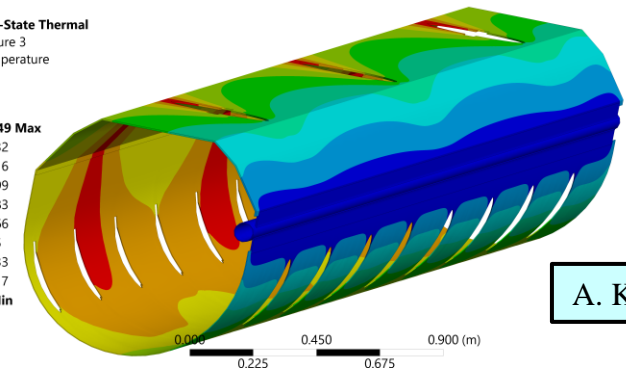
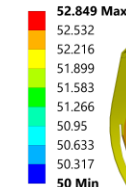

A. Kumar

(FY2025) (2)WPP2: Progress of infrastructure in COI building



Cryogenics

- TRT under production, to be installed in next FY
- Design of 2K cold box finished
- High pressure gas safety act
- Control system under updating

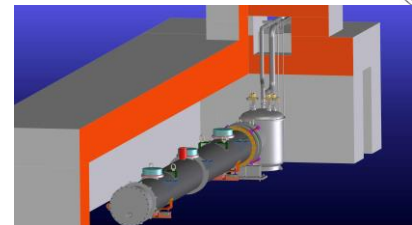
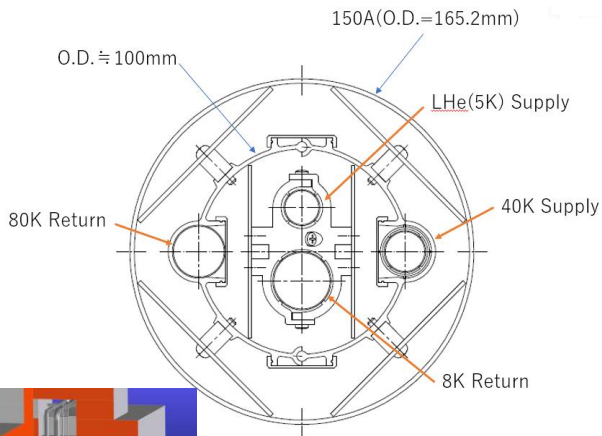

RF system

- RF components under production/testing
- Resonant ring system ready for high power test
- Design of waveguide system attached to CM
- Design of long-distance waveguide system from STF to COI

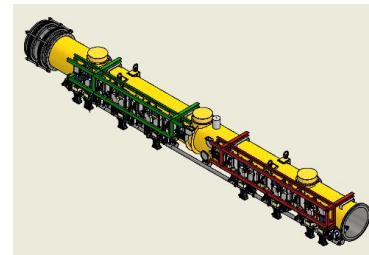
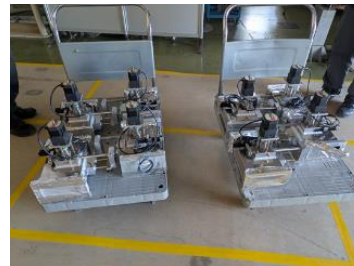
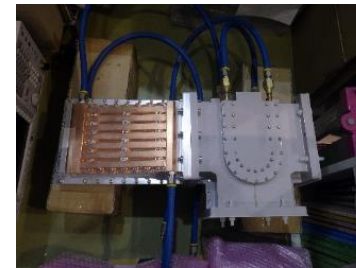

Cryomodule Test Bunker

- Floor reinforcement work was complete (750t)
- Design of concrete shielding
- Consideration on CM transport



Undulator scheme and e-driven scheme positron source



Undulator method (baseline): 125 GeV electrons are passed through a helical undulator, and the produced gamma rays hit the target to produce electron-positron pairs. Polarized positrons (30%) are obtained. Need 125 GeV electron beam.

WPP 6,7

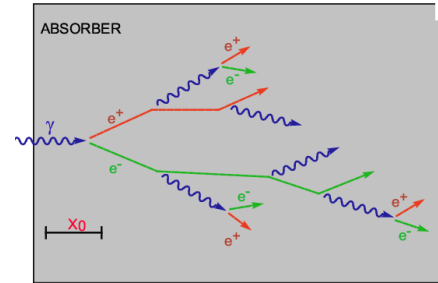
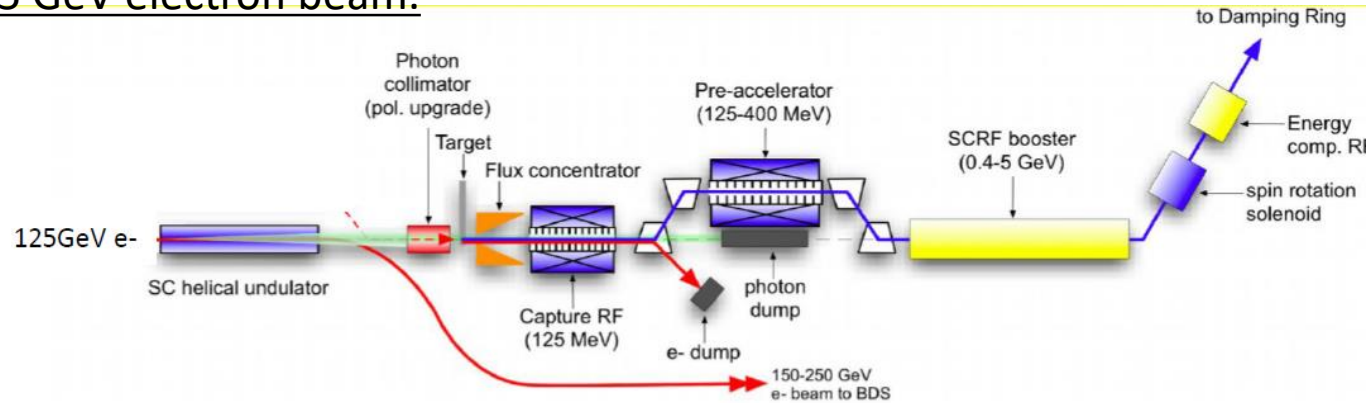

Developed in mainly EU.

Electron driven method : 3GeV electrons hit the target to produce electron-positron pairs. High-energy electrons are not required, and the commissioning of the positron production is independent from electron beam commissioning.

WPP 8,9,10,11

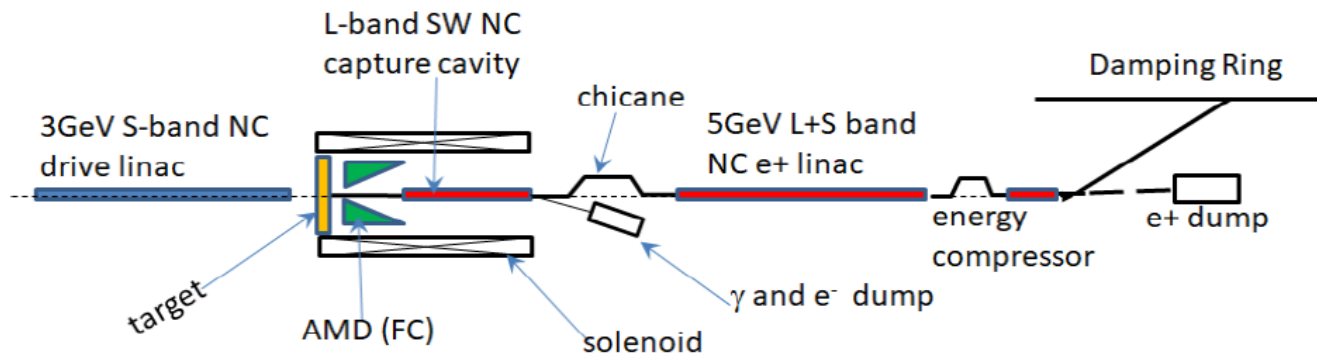

Developed mainly in Japan.

Both needs strong target and sophisticated design of Flux concentrator and capture section (cavity and solenoid) → In KEK, prototype of positron source based on e-driven method start to develop.

Positron source in KEK

- Made test stand to evaluate the following items
 - Evaluation of rotating target is in progress
 - Thermal test by adding heat load of 20 kW (next page)
 - Continuous operation of rotating for more than one Start to fabricate accelerator structure
 - Test cell and all cells of Acc structure under fabrication and test of brazing.
 - Test of power supply of solenoid
 - Start to fabrication of power supply of Flux Concentrator .
- Tracking simulation is in progress.

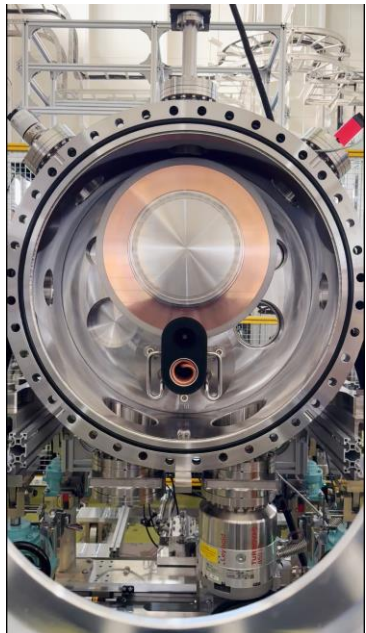
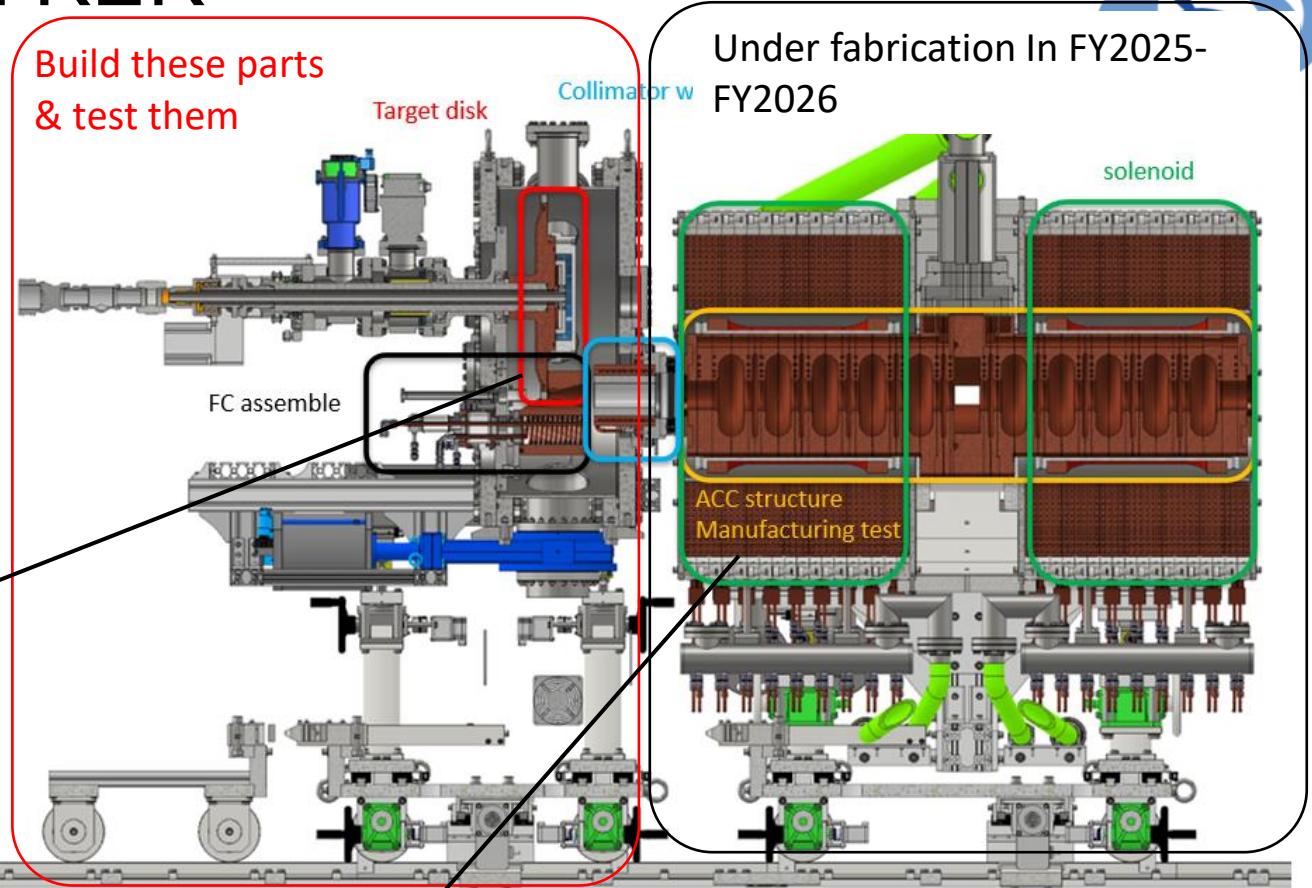

rotating target.

Accelerator structure under fabrication of each cell & brazing. continue to FY2026.

About 200 r p m with water cooling. Vacuum is around 10^{-6} Pa level. (FY2024-2025). Now continue long-term operation.

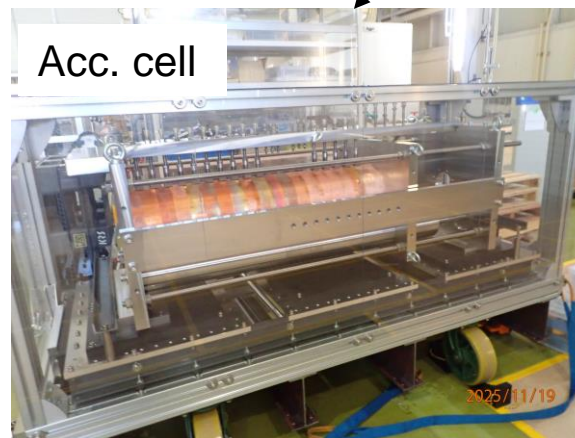

Acc. cell



Plan view of our test stand



Temperature distribution and Thermal conductivity

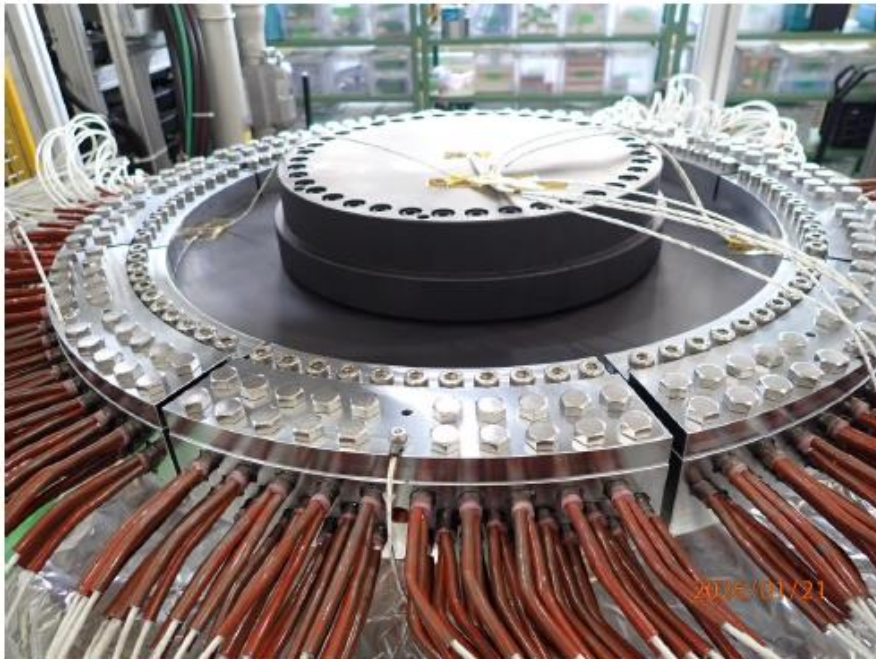

- Temperature distribution and thermal conductivity of target disk were evaluated.
- This test was done two times and finally in Jan. 2026.
- Increase input power to the target up to 20 kW and temperature is less than 200 deg. (see the following figure)
- No drastic temperature increase was found → W/Cu smoothly contact and can cooled via the shrink fit of W/Cu.
- We think that this target will satisfy our requirement of 27 kW beam deposit for positron production.

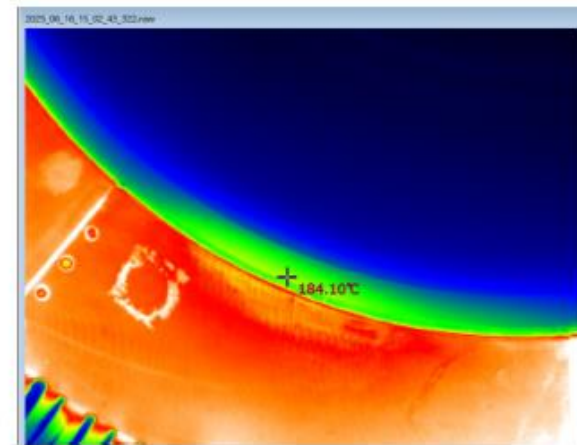
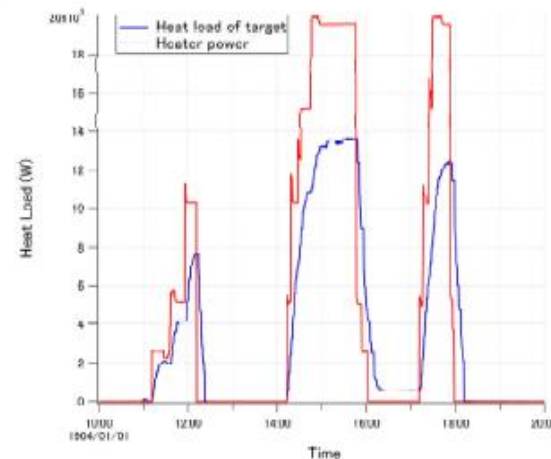

WPP-15: Final focus at ATF in KEK



Goal 1: Establish the ILC final focus method with same optics and comparable beamline tolerances
 ATF2 Goal : **37 nm** → ILC **7.7 nm** (ILC250); **achieved 41 nm** (2016)

Goal 2: Develop the position stabilization for the ILC collision
 ● **FB latency 133 nsec achieved** (target: < 366 nsec)
 ● **positon jitter at IP: 106 → 41 nm (2018)** (limited by the BPM resolution)

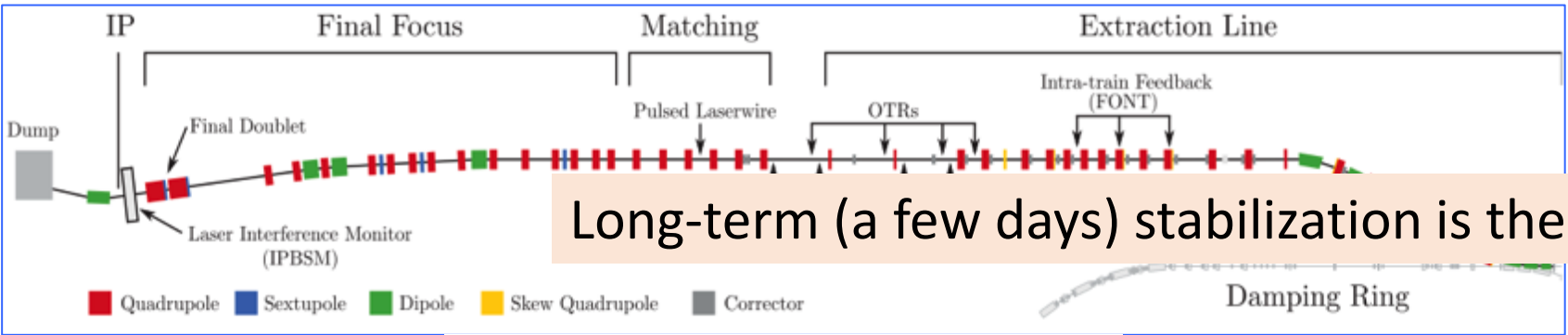

Long-term (a few days) stabilization is the goal of WPP-15

Nano-meter stabilization at IP (2018)

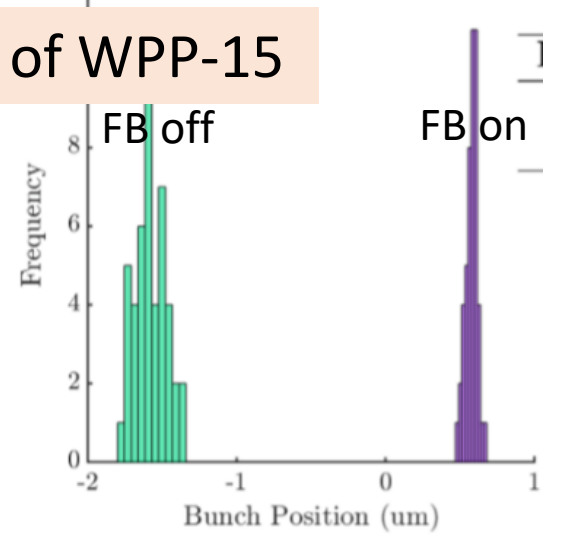
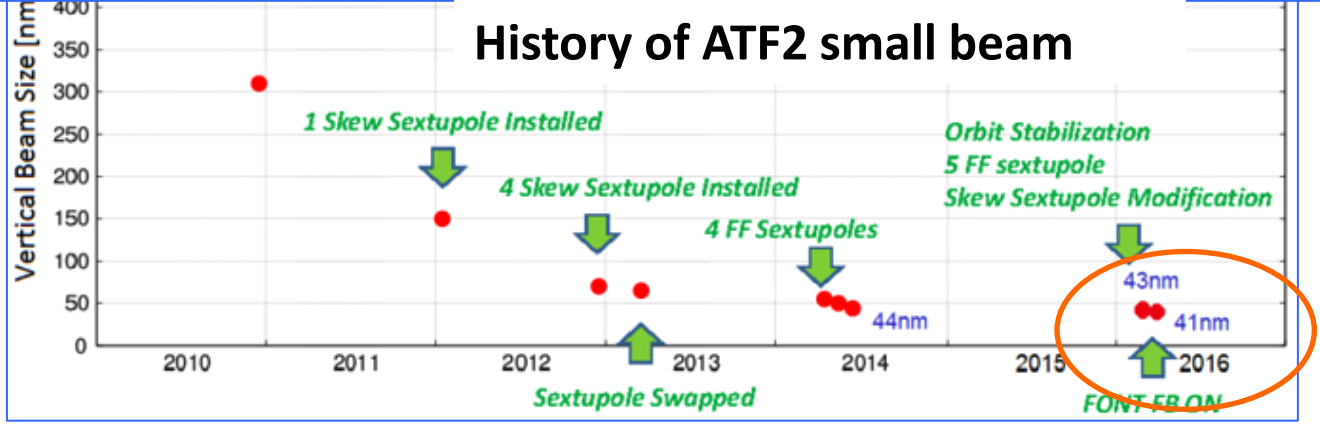

ATF activities in FY2025

1.28 GeV

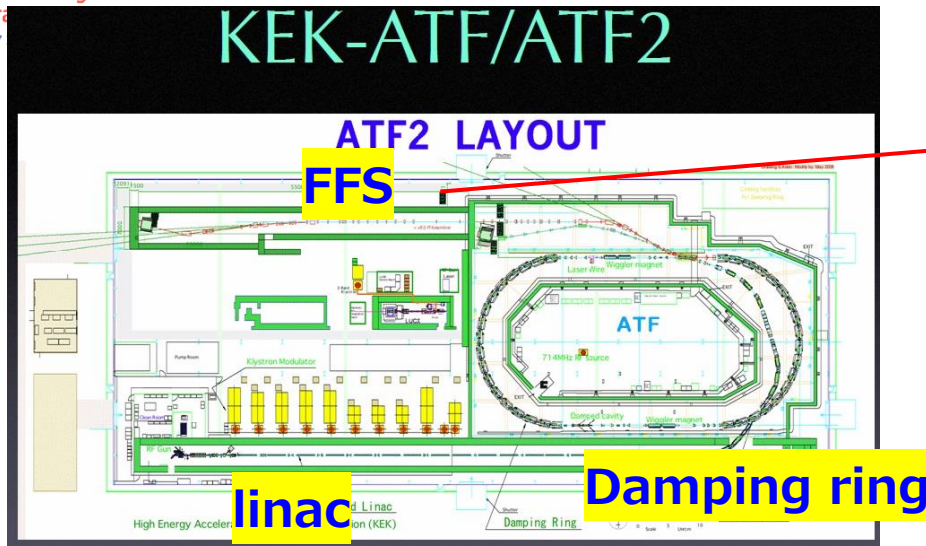

Final focus system (FFS)
 (goal 37nm@1.28GeV,
 which equals to 7.7nm @125GeV)



List of correctors to use.

List of BPMs to use.

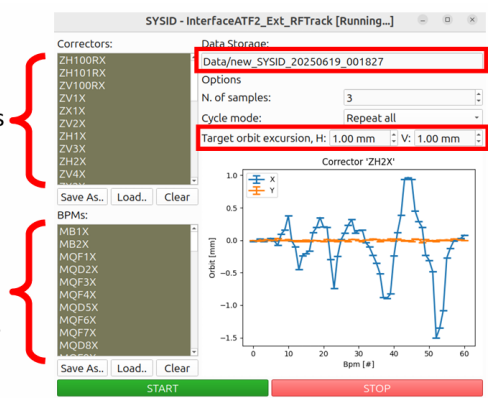

Flight simulator for FFS

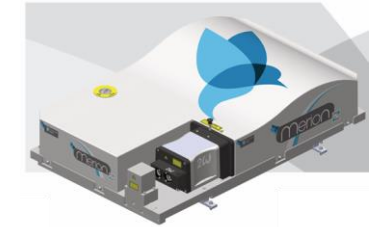

Laser power supply



New laser system for IP beam size monitor

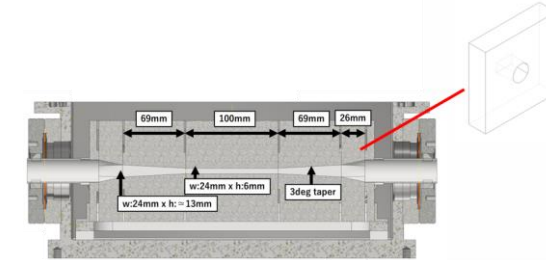

Wake field measurement

Continue development of nanobeam technology

- 14 week beam operation in for international collaboration and more reliable operation
- Install of multipole magnets to reduce higher-order aberrations on FFS.
- Upgrade vacuum chamber to suppress wakefield
- Upgrading of all magnet position control system
- Upgrade beam size monitor in IP (Buy laser)
- Recently, we produce 60-70 nm on FFS in 2026.Mar..

Keep international collaboration

- Development of beam technology applicable to ILC
- **AI nano-beam tuning under international collaboration with flight simulator** (CERN, KEK and so on)
- → This will improve beam tuning
- Upgrading Beam Monitor

→ Continue upgrading ATF2 (ATF3) Beamline to be optimized for ILC.

On November 2025, we held **ATF project meeting** under our international collaboration to **focus nanobeam generation and stabilization for next two years.**

<https://agenda.linearcollider.org/event/10859/>

Advancing of the IP beam size measurement after the IP-BSM laser renewal



- The accuracy of the beam size monitor improved after the laser was replaced.
- With the hardware upgrade, preparations for beam adjustment starting in fiscal year 2026 are now complete.

ATF IP beam size monitor

By comparing the beam with the laser interference pattern, the beam size can be evaluated.

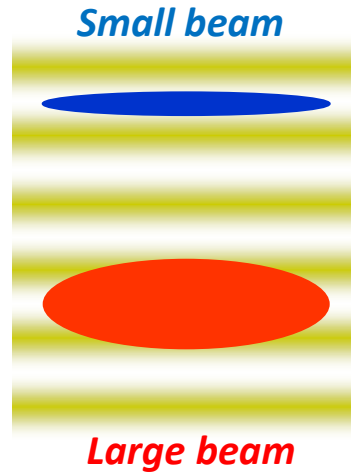
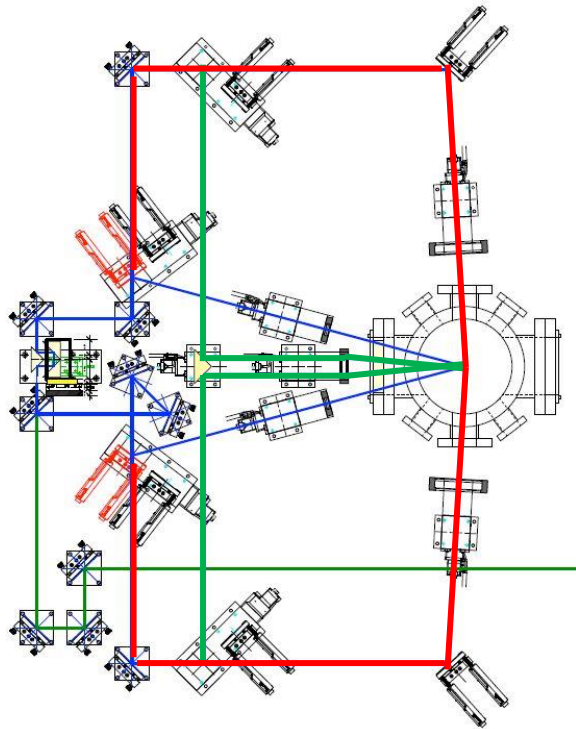

Dynamic range of ATF IP-BSM

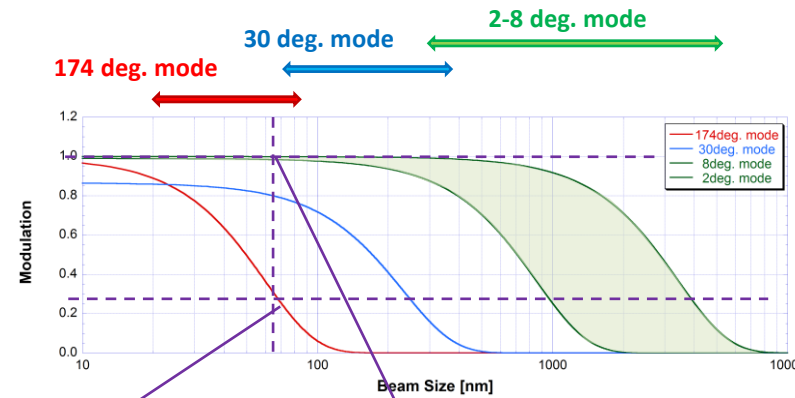

The same beam size was measured in different cross angle modes, the modulation in each mode was as expected.

66nm beam size measurement **stably** was done in 2026.Mar.

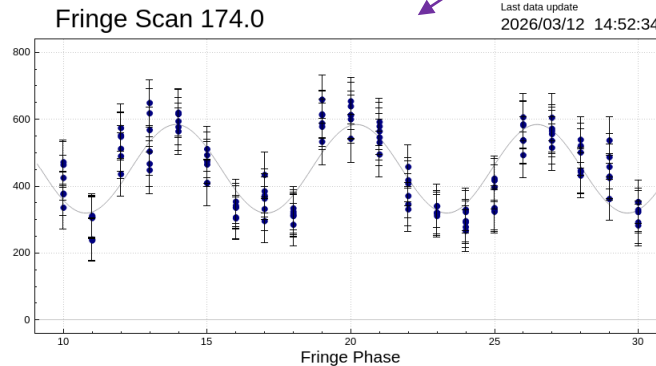

Laser mirror/lens settings: Fit: Average*(1 + Modulation*cos(Phase-offset))
 HWP-IN :0.0000 M174LX: 9.9508 M174UX: 9.6971 Modulation: 0.293 +/- 0.018
 HWP-U: 0.0000 M174LY: 9.0356 M174UY: 11.2319 beam size: 66.3, -1.7, +1.7 nm
 HWP-L: 0.0000 F174L: -0.50 M174LS(tilt): 0.00 Average: 451.8 +/- 6.1
 F174U: -2.50 M174US(tilt): 0.00 Phase offset: -1.35 +/- 0.07
 Chi2/n.d.f: 123.3 / 123

Raw data file: /atf/data/ipbsm/archive/binary/base260312_145052.binary

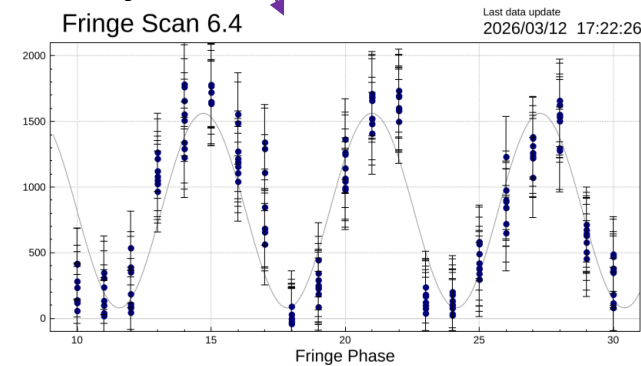

Laser mirror/lens settings: Fit: Average*(1 + Modulation*cos(Phase-offset))
 M8LX: 8.8128 M8UX: 9.1755 Modulation: 0.901 +/- 0.043
 M8LY: 8.2096 M8UY: 9.4268 beam size: 335.5, -92.4, +75.2 nm
 FB: -0.60 Average: 823.6 +/- 23.0
 Phase offset: -2.13 +/- 0.04
 Chi2/n.d.f: 170.2 / 165

Raw data file: /mnt/vtrak/ipbsm/online/Fringe8.dat

(important message)

It became possible to generate ideal interference fringes at ATF IP after the laser was replaced, .

JFY2026-2027 is very important to fulfill nanobeam generation (<37nm) and stabilization (for a few days)



SRF technology applications:

- ex. **Semiconductor lithography (EUV-FEL)**, medical application, environmental remediation, etc. → cERL in KEK

Applications of Sources technology (positron)

- In the future, more intense positron sources will be needed not only for linear collider but also for **circular colliders** such as FCCee and CEPC.
- High-intensity **slow positrons** are expected for surface structure analysis.
- Positron targets are also closely related to **targets for neutron and beam irradiation** used in industrial medical applications.

Applications of nano-beam technology (ATF):

- Synergy about nanobeam operation in **new-generation synchrotron light source**,
- Advancement of **beam diagnostics**, beam tuning by **machine learning**, **beam control technology** on the nanosecond scale can be applied to a **wide range of accelerators**.

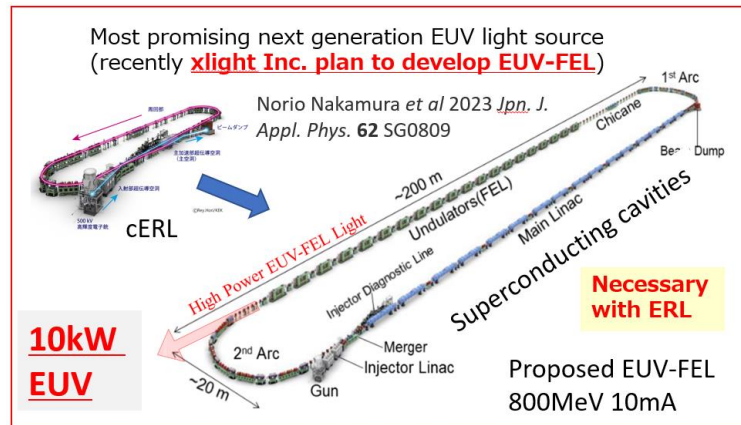

EUV-FEL by advanced SRF technology

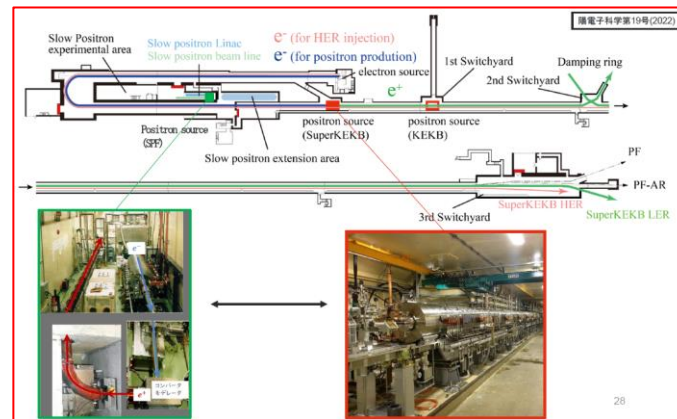

Slow positron facility by advanced source technology



Synergy about new-generation light source

(C)



Contents :

A) Overview & ILC Technology Network (ITN)

B) ILC activities in JFY2025 (mainly Japanese activities on MEXT-ATD)

C) Summary and Future plan (JFY2026 ~)

Summary & future



- ILC accelerator development is on-going under the framework of ITN and mainly supported on MEXT-ATD program, JFY2023-2027 in Japan.
- Until JFY2025, we conducted 3 critical accelerator technologies, such as SRF, nanobeam and positron under MEXT-ATD program.
- Worldwide ITN activities - the European & Korean contribution - are well underway.
- **Many activities of ITN about this SRF, nanobeam and positron were on going in Japan under MEXT-ATD with world wide contribution.**
- In JFY2026, we also continue to develop these 3 critical accelerator technologies to realize ILC under ITN.

Acknowledgements



KEK iCASA members
(+a) (2026.Apr.)

- This work was supported by “MEXT Development of key element technologies to improve the performance of future accelerators Program”, Japan Grant Number JPMXP1423812204
- This work was partially supported by U.S.-Japan Science and Technology Cooperation Program in High Energy Physics (2022-19-3) (2025-04-3).



Backup

History of ILC Collaboration

応用超伝導加速器イノベーションセンター

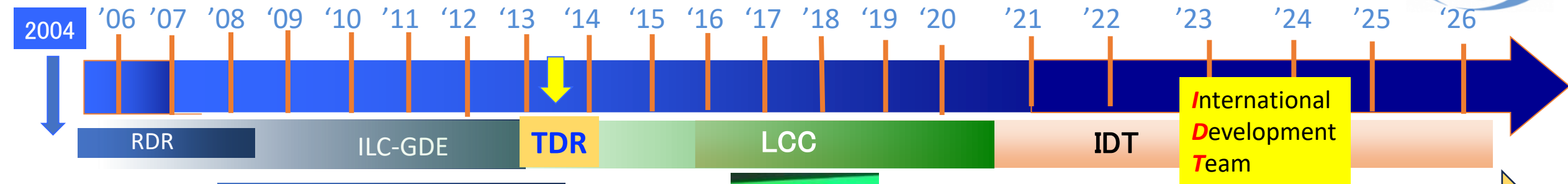

Technology Selection by ITRP



Lyn Evans
LCC director
(former LHC project manager)



Tatsuya Nakada (EPFL)
IDT chair

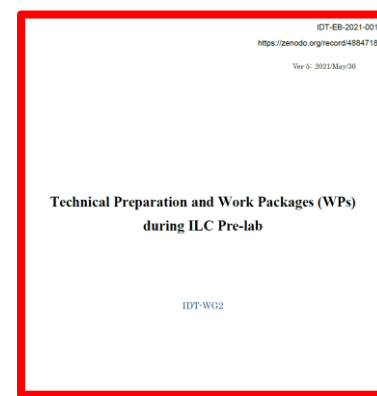
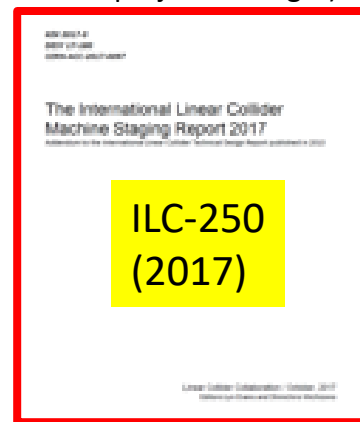
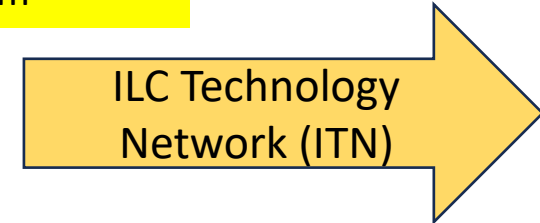

Pre-lab workpackages
(May 2021)

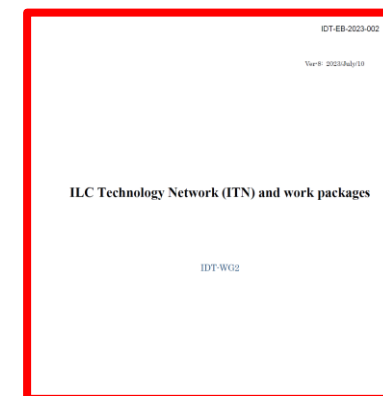

ILC Technology Network
(July 2023) ²⁶

ITN in progress all over the world



For **WPP-1&2 (SRF cavity, CM)**, single cell cavity production in Korea/Europe and 9-cell cavity production in Europe started.

For **WPP3 (Crab cavity)**, Prototype designs down selected under world wide review.

JAI (UK) started WPP-14 (DR Injection/extraction, **synergy with Diamond Light Source upgrade**)

For **WPP-15 (Final Focus System)**, European and Korean researchers have joined to the ATF experiments since 2023.

1st meeting on Oct. 2023 @CERN/hybrid

2nd meeting on July 2024 @Tokyo/hybrid

3rd meeting on Oct. 2024 @Valencia

just after LCWS2025 in hybrid mode

- ~30 researchers joined to the meeting.
- Status of each **work-package** was reported.
- **ITN midterm report** was discussed. (published)

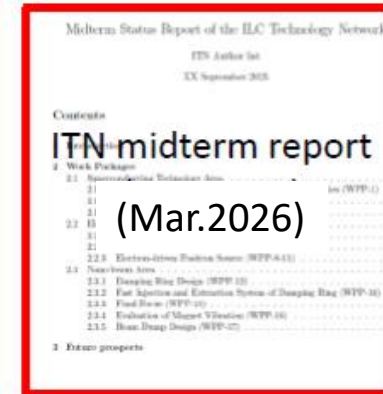

(published to arXiv on 2026.Mar.1st)
<https://doi.org/10.48550/arXiv.2603.01172>

WPP-1/2 in Asia

SRF activities in Asia for ITN

Yoshiko Yamamoto, on behalf of ILC WPP1-2 SRF Group in Asia

WPP-1/2 in Europe

SRF activities in Europe

L. Monaco INFN Milano - LASA
On behalf of the ITN-EU colleagues (WPP1, WPP2)

CRAB CAVITIES FOR ILC: OBJECTIVES

WPP-3

Collaborative Design Eff.
ILC WPP3 involves design & working together to deliver

Design Selection Process
Five initial designs were narrowed down to two prototypes by April 2023, with a final decision expected in October 2024.

Project Objectives
The goal is to deliver a robust crab cavity system meeting performance and space requirements within the ILC interaction region.

WPP-8-12

E-driven positron source

2025/10/24
Y. Enomoto

WP undulator-based positron source

WPP-6/7

• Overview WP
• Ongoing ITN work:
- Rotating Wheel Design
- Pulsed Solenoid
- Plasma Lens
• Conclusion

Seung-Mo Kang et al.

WPP-12 Damping Ring Design

WPP-12

ILC Damping Ring

Damping rings are located just after the electron linac to reduce the beam emittance structure.

- Beam emittance are reduced in the DR section
- The beams are cooled by compressing the beam
- The beams are captured/extracted directly from the damping ring

Electron Energy	50 GeV
Beam Energy	5 GeV
RF Frequency	400 MHz
Beam Current	100 mA
Number of bunch	2000
Bunch length	100 ps
Normalized emittance (x, y, z)	43, 43, 7.0 nm
Electron radiation (x, y, z)	400, 400, 400 nm
Long. Emittance (dE/E, σ_x)	25/70% / 20 mm
Damping time (x, y, z)	20 ms / 20 ms / 12 ms
RF power	200 MW

WPP-14

Pulsar Development for the ILC Damping Ring Kickers

Philip Burrows
University of Oxford
Director, John Adams Institute for Accelerator Science

WPP-15

The work area of nanobeams:

A. Fass-Galle

Status of the WPP-17 Main beam dump

WPP-17

Nobuhiro Terunuma, KEK

On-going technical studies in Europe – the ILC technology network topics

European ITN related studies (dedicated funding from Japan combined with European resources) are distributed over five main activity areas:

ML related tasks

- SRF and ML elements: **Cavities** and Cryo Module, Crab-cavities, ML quads and cold BPMs
→ **at least 2 nine cell cavities under fabrication by EU (CERN, INFN, CEA)**

Sources

- Pulsed magnet and wheel/target for undulator scheme

Damping Ring including kickers

- Low Emittance Rings

ATF activities, final focus and nanobeams

- ATS and MDI

Implementation

- CE(civil engineering), Cryogenics
- Sustainability, Life Cycle Assessments
- EAJADE (EU funding) for training of young scientists (linear and circular machines)

Studies in labs distributed across CERN, UK, Germany, France, Italy, Spain

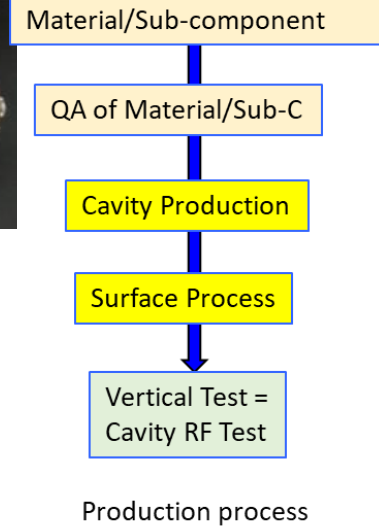
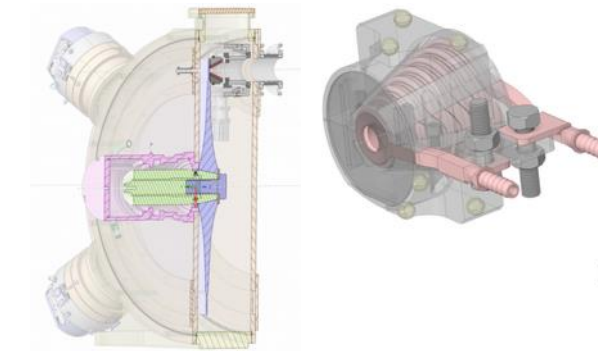

Results from FG 9-cell cavity using 2-step baking **KEK and FNAL**

Possible to achieve > 40 MV/m with high Q_0

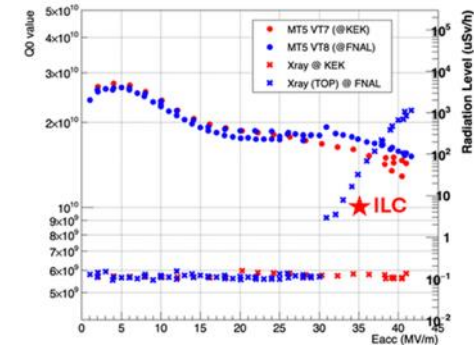

See more details in the Venice presentation of Peter McIntosh ([LINK](#)) and Angeles Faus-Golfe on ATF2-3 ([LINK](#))

About human resources for MEXT-ATD (~ FY2025)



For completing this MEXT-ATD project, we hired many young researchers. (in total 6 persons)

- In JFY2023, one postdoctoral fellow was hired.
 - Popov Konstantin (nanobeam ATF), From 2023.Oct. → Assistant professor from 2024.Oct. → moved to company (Kazakhstan) from 2026.Jan.
- In JFY2024, four special assistant professors were hired.
 - Takafumi Hara (SRF), from 2024.Apr.
 - Motoki Sato (Positron), from 2024.Apr. → (nanobeam ATF) from 2025.Jun.
 - Bajipai Rishabh (SRF), from 2024.Dec.
 - Eric Viklund (SRF), from 2025.Jan.
- In JFY2024, one postdoctoral fellow was hired.
 - Yuki Abe (nanobeam ATF), from 2024.Apr. → Assistant professor from 2025.Jul.



Popov Konstantin
(nanobeam ATF)
(2023.Oct. ~ 2026.Jan.)



Takafumi Hara
(SRF)
(2024.Apr. ~)



Motoki Sato
(Positron →
Nanobeam ATF)
(2024.Apr. ~)



Yuki Abe
(nanobeam ATF)
(2024.Apr. ~)



Bajipai Rishabh
(SRF)
(2024.Dec. ~)

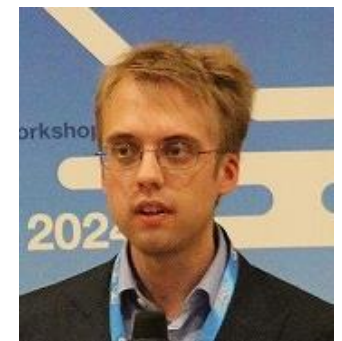

Eric Viklund
(SRF)
(2025.Jan.. ~)

Typical IP-BSM measurement on 2026.Mar. operation

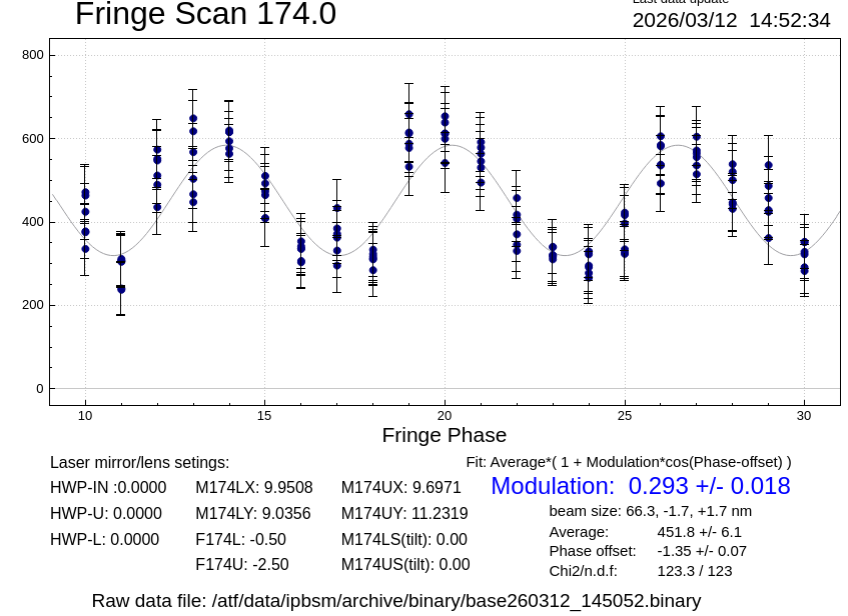
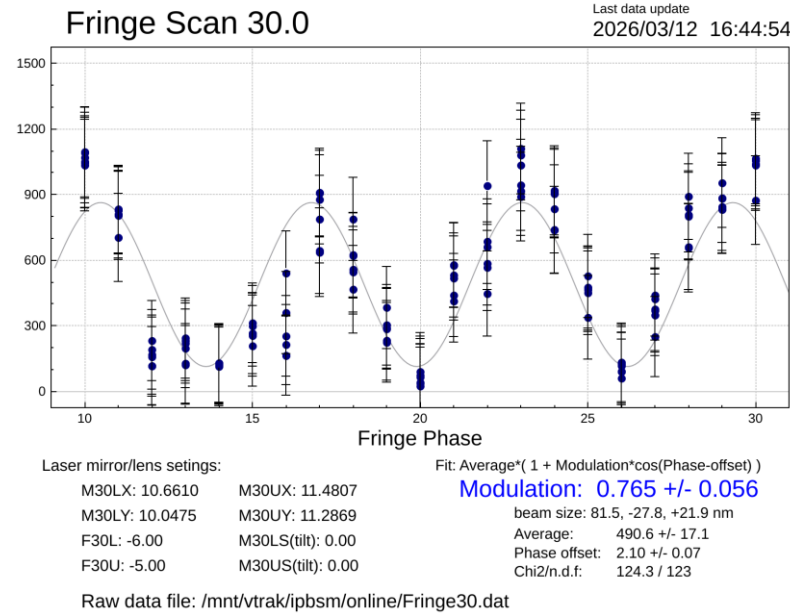
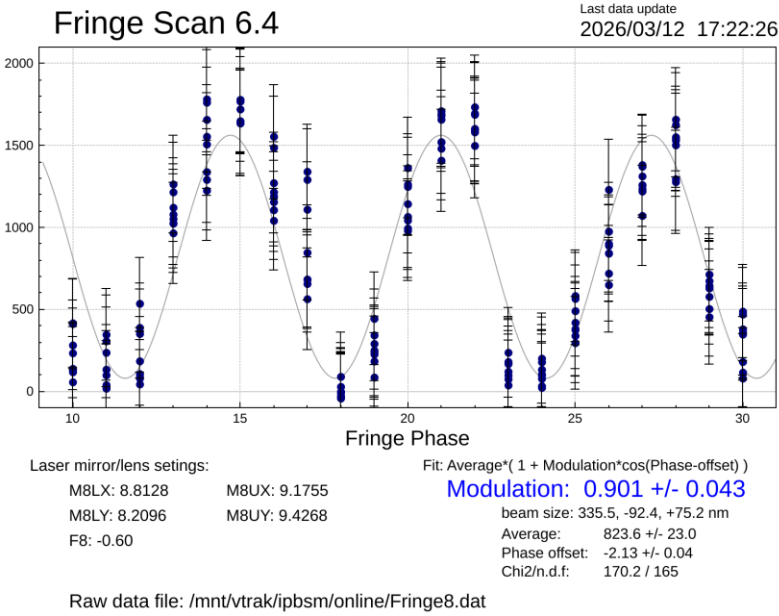

Crossing mode	Typical measured modulation	Modulation of 75nm beam	Modulation of 65nm beam
6.4 degree	90 %	98.9%	99.0%
30 degree	75-80%	78%	80%
174 degree	20-30%	20%	30%

We can stably measure the beam size at FF in ATF with beam size tuning

(important message)

JFY2026-2027 is very important to fulfill nanobeam generation (<37nm) and stabilization (for a few days)

Five-Year Plan and Progress in midterm (nanobeam) (ATF) under MEXT-ATD program (FY2025) → our mission



	2023	2024	2025	2026	2027
Nanobeam	<ul style="list-style-type: none"> ✓ Procurement of High-Order magnets ✓ Upgrade of beam operation and equipment 	<ul style="list-style-type: none"> ✓ Reduction of wake field and higher order aberration ✓ Upgrade of beam operation and equipment 	<ul style="list-style-type: none"> ● Precise measurement of nanobeam, ✓ Upgrade of beam operation and equipment 	<ul style="list-style-type: none"> ● Improvement of beam turning method (incl. AI) ● Vertical beam size on IP <37nm 	<ul style="list-style-type: none"> ● Improvement of beam turning method (incl. AI) ● Long-term stabilization of nanobeam (for a few days)

- The first three years (FY2023-2025) will focus primarily on updating ATF equipment necessary for advancing the nanobeam. **The subsequent two years will realize nanobeam generation and stabilization using the updated equipment.**
- **The procurement of equipment, its installation on the beamline, and performance test of the installed equipment have proceeded on schedule until now.**
- Following picture is our progress of preparing items. **Procurement of major equipment for the ATF2 beamline will be completed in JFY2025.**

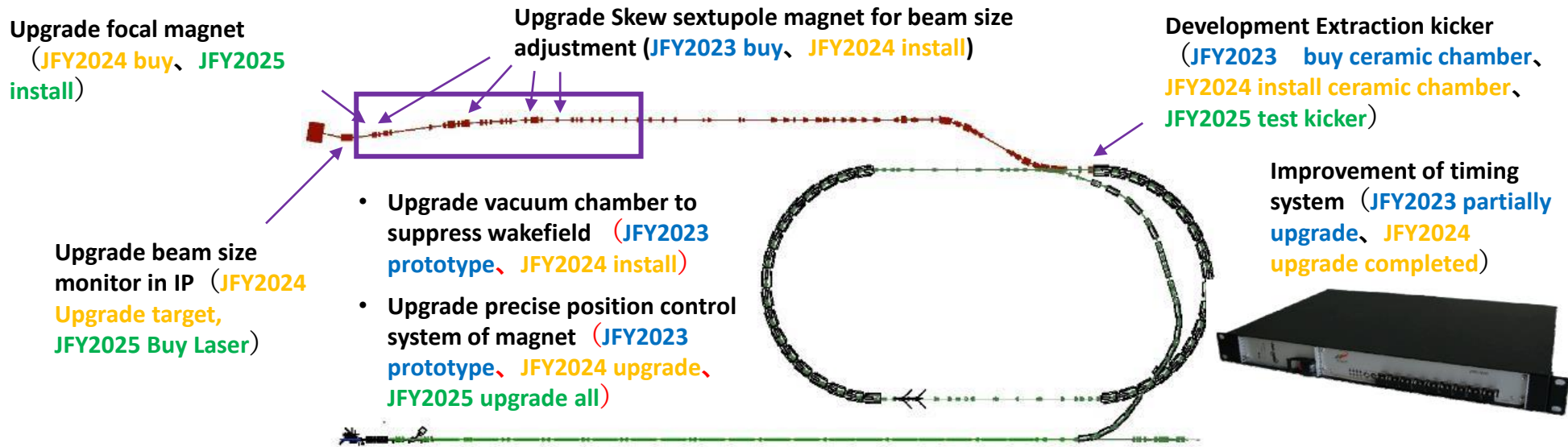

(important message)
Next two years is very important to fulfill **nanobeam generation (<37nm)** and **stabilization (for a few days)**
(Mission of MEXT-ATD program (ATF operation budget come from this MEXT-ATD program))

The current status is as planned.

ITN goal is same as our MEXT-ATD program