

# Production and Installation Policy of IP-BPM

ATF2 Project Meeting, 2006/12/18

Y. Honda, Y. Inoue, T. Hino, T. Nakamura

# Contents

---

## **1, Review**

- 1-1 Goal of IP-BPM
- 1-2 Basic idea of IP-BPM

## **2, Current status**

- 2-1 Design confirmation
- 2-2 Pulse shape
- 2-3 R/Q measurement
- 2-4 Electronics tests
- 2-4 Position sensitivity
- 2-5 Angle sensitivity
- 2-6 Position resolution

## **3, Tasks ahead**

- 3-1 Mover tests
- 3-2 Bunch length monitor and Beam charge monitor
- 3-3 Tasks ahead

## **4, Summary**

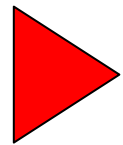

**1, Review**

---

**2, Current status**

**3, Tasks ahead**

**4, Summary**

# Goal of IP-BPM

---

The two main goals of ATF2 are achieving 37nm beam size and nanometer controlling of beam position. IP-BPM is one of the most important player to achieve the nanometer control of beam position.

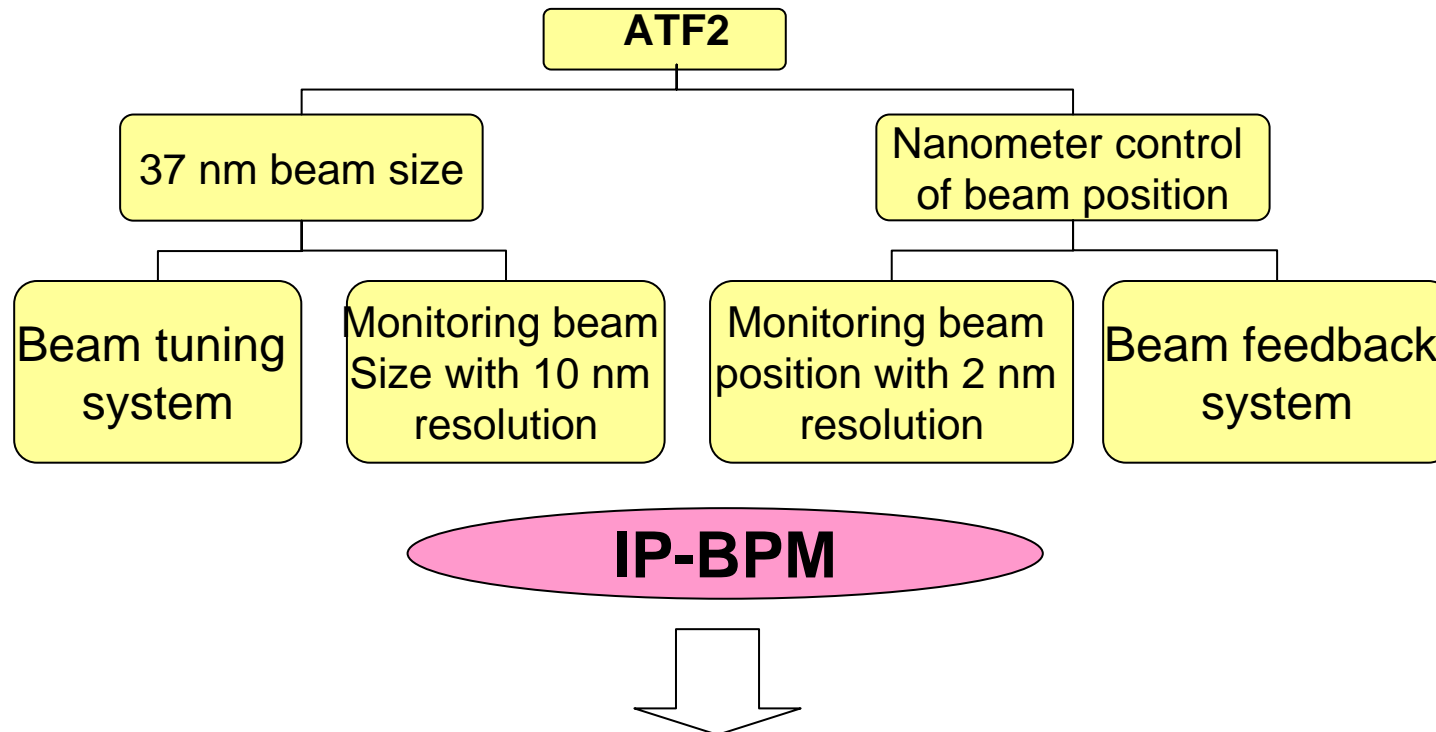

**Goal: 2nm position resolution**

# Basic Idea of IP-BPM

**IP-BPM is a cavity BPM which will be installed at the Interaction Point. The beam would excite di-pole mode in the cavity and the output signal will be proportional to the beam position.**

## ■ Principle of cavity BPM

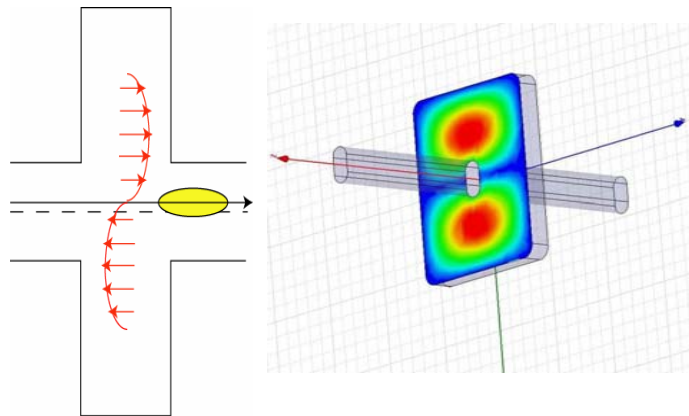

The beam entering the cavity with offset will excite a di-pole mode (TM<sub>120</sub> or TM<sub>210</sub>). The excited signal will be read out by a slot coupler to the wave guides.

## ■ Characteristics of IP-BPM

- 1, X-Y isolation (rectangular cavity, resonant frequencies are 5.712 GHz, 6.426 GHz respectively.)
- 2, Low angle sensitivity (small aperture, high coupling constant to retain position sensitivity)

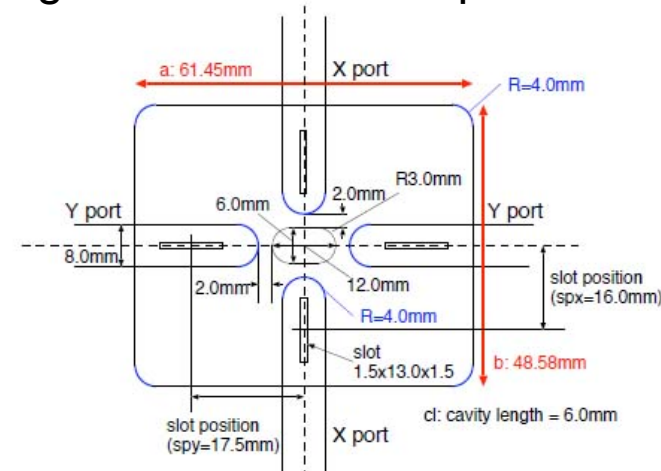

**1, Review**

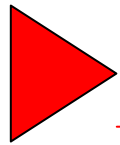

**2, Current status**

**3, Tasks ahead**

**4, Summary**

# Current status

---

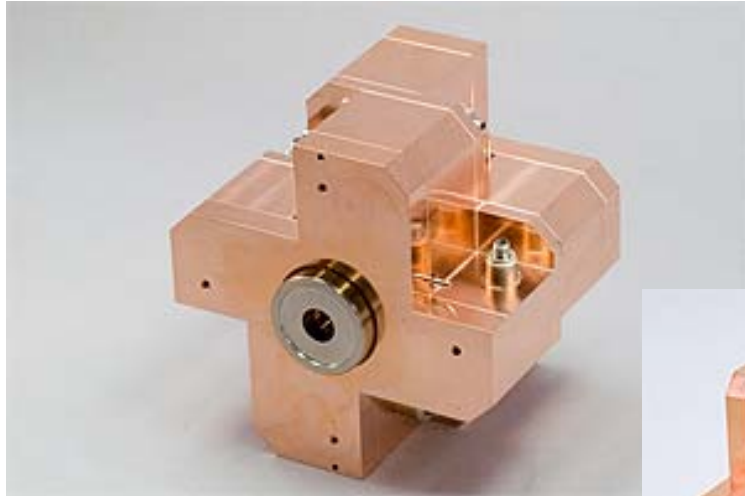

We now have 2 IP-BPMs (4 Cavities, 2 in one module) fabricated.

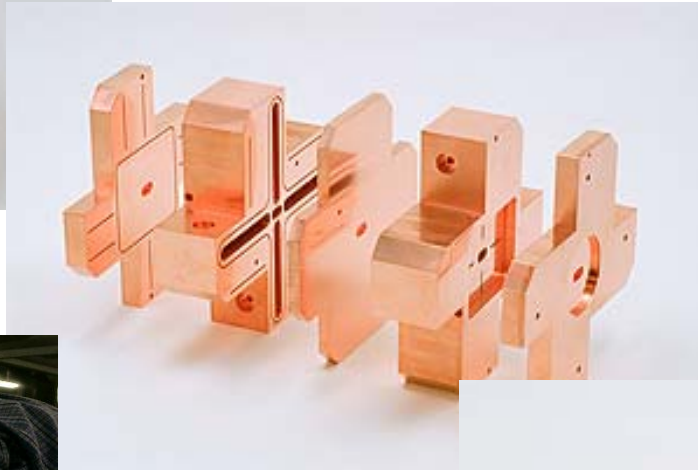

Special thanks to Mr. N. Toge



# Current status

We have carried out beam tests for checking position sensitivity, angle sensitivity, and position resolution.

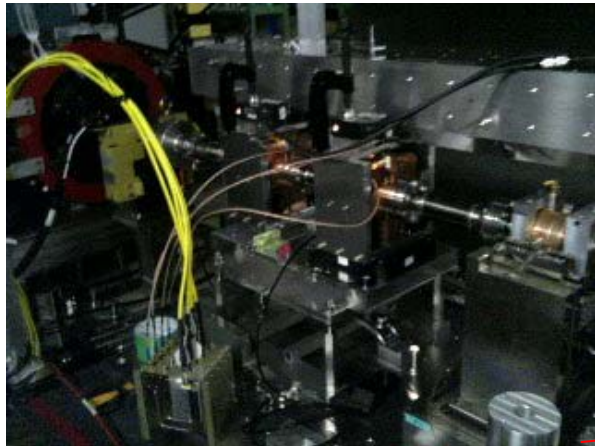

Now, they are installed in the extraction line of ATF

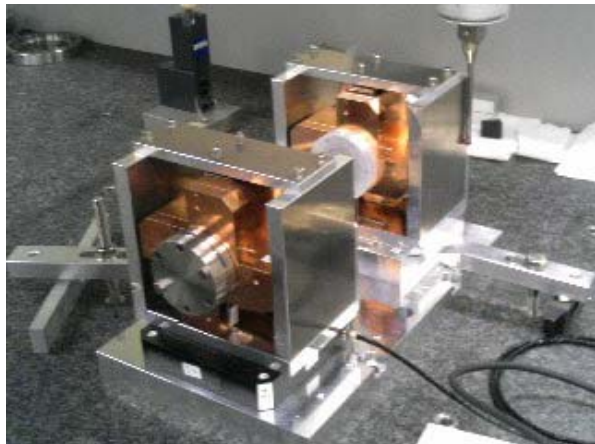

2 IP-BPMs (4 cavities) with one on a piezo actuator

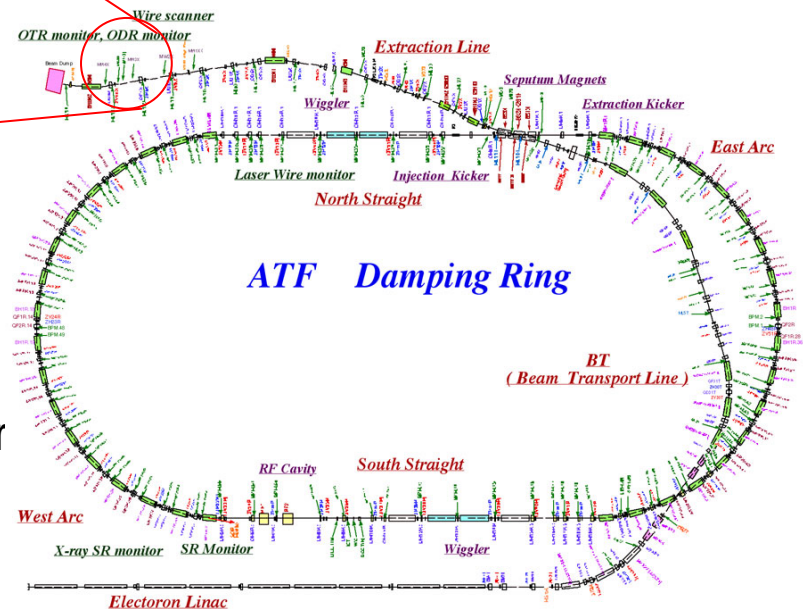



# Design confirmation

We checked the basic parameters with the network analyzer. The IP-BPMs are fabricated as they were designed.

	Port	$f_0$ (GHz)	$\beta$	$Q_0$	$Q_{ext}$
X	design value	5.712	1.4	5300	3901
	simulation value (Transmission)	5.7086	1.58	5336	3382
	simulation value (Reflection)	5.7086	1.63	5424	3335
Y	design value	6.426	2.0	4900	2442
	simulation value (Transmission)	6.4336	3.15	5015	1590
	simulation value (Reflection)	6.4336	3.32	5259	1586

表 5 IP-BPM design value (di-pole mode)

Port	$f_0$ (GHz)	$\beta$	$Q_L$	$Q_0$	$Q_{ext}$	$\tau$ (ns)
A (X)	5.7072 (5.7081)	2.21 (1.85)	2232 (2386)	7172 (6808)	3241 (3674)	62.2 (66.5)
B (Y)	6.4213 (6.4233)	11.06 (3.35)	2300 (2107)	27738 (9167)	2508 (2735)	57.0 (52.2)
C (X)	5.7073 (5.7081)	1.22 (3.24)	2340 (1995)	5235 (8464)	4232 (2610)	65.3 (55.6)
D (Y)	6.4211 (6.4231)	3.19 (3.17)	1962 (1972)	8228 (8226)	2577 (2594)	48.6 (48.9)
A-C (X)	5.7073 (5.7081)	1.38 (1.51)	2146 (1985)	5116 (4982)	3695 (3301)	59.8 (55.4)
B-D (Y)	6.4202 (6.4219)	3.03 (2.75)	1200 (1274)	4834 (4780)	1595 (1737)	29.7 (31.6)

表 1 IP-BPM1 upper cavity (di-pole mode)

Port	$f_0$ (GHz)	$\beta$	$Q_L$	$Q_0$	$Q_{ext}$	$\tau$ (ns)
A (X)	5.7075 (5.7078)	1.18 (1.58)	2383 (2318)	5199 (5986)	4400 (3784)	66.5 (64.6)
B (Y)	6.4219 (6.4226)	4.93 (6.16)	1360 (1496)	8057 (10722)	1636 (1739)	33.7 (37.1)
C (X)	5.7065 (5.7068)	6.43 (4.96)	2910 (3010)	21621 (17938)	3363 (3617)	81.2 (83.9)
D (Y)	6.4219 (6.4225)	1.40 (2.84)	1678 (1482)	4035 (5697)	2873 (2004)	41.6 (36.7)
A-C (X)	5.7075 (5.7079)	1.32 (1.49)	2174 (2031)	5036 (5050)	3826 (3398)	60.6 (56.6)
B-D (Y)	6.4217 (6.4222)	2.66 (2.60)	1304 (1335)	4777 (4807)	1793 (1848)	32.3 (33.1)

表 2 IP-BPM1 bottom cavity (di-pole mode)

- ★ The resonant frequencies correspond in a few MHz.
- ★ X-Y isolation is under -50 dBm.

# R/Q measurement

R/Q is an important factor independent of cavity material or surface condition. It is proportional to square of offset, therefore the output signal of di-pole mode would be proportional to beam offset.

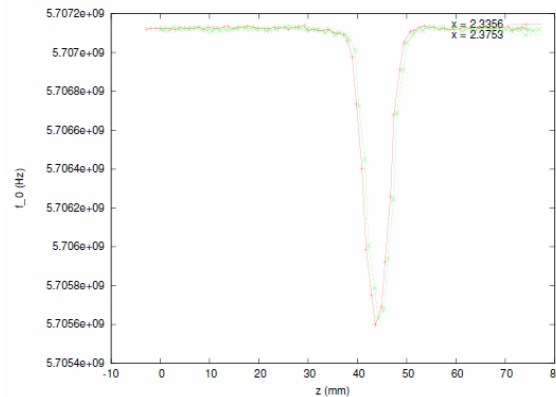

R/Q measurement: scanning the cavity by a small bead



To measure R/Q of the cavity, we introduced small perturbation and monitored the variance of the resonant frequency.

$$\frac{R}{Q} = \frac{|\int \sqrt{|\Delta f|} ds|^2}{\pi f_0^2 \epsilon \Delta V}$$

R: Shunt impedance  
Q: Quality factor

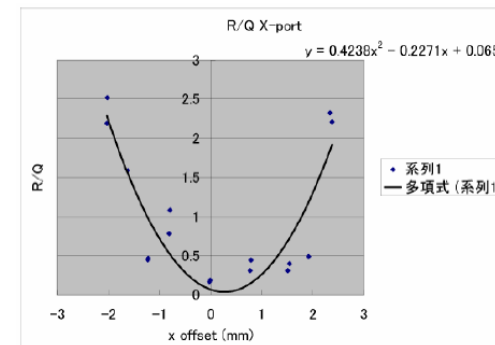

R/Q was proportional to  $x^2$ , as simulated. The signal will be proportional to square root of R/Q, therefore the signal will be proportional to  $x$ .

# Electronics tests

The converter module newly made for IP-BPM was tested in detail. Specification of each component was checked independently. Overall test of the electronic system was done in the actual location in the ATF tunnel. It was confirmed that the system had the sensitivity enough to detect nm beam position signal.

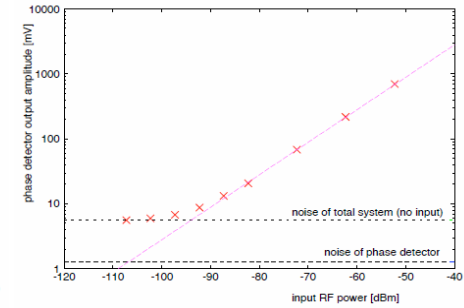
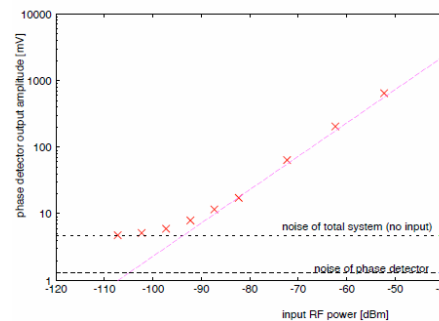
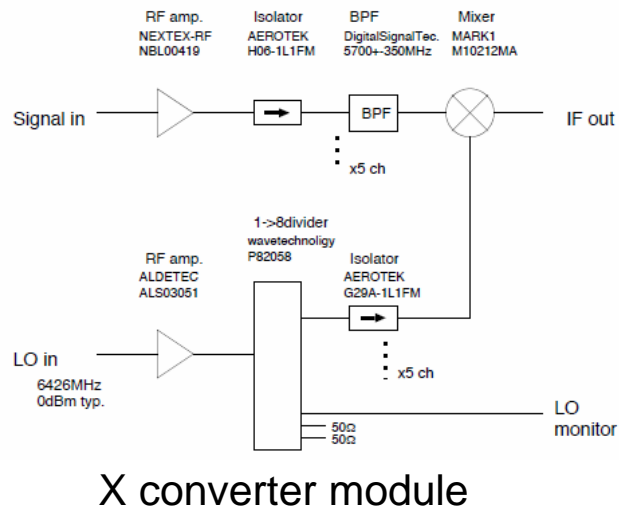

The 1nm position signal would be about -90 dBm. The detection limit of the whole system is about -95 dBm, which enables to detect nm position signal.

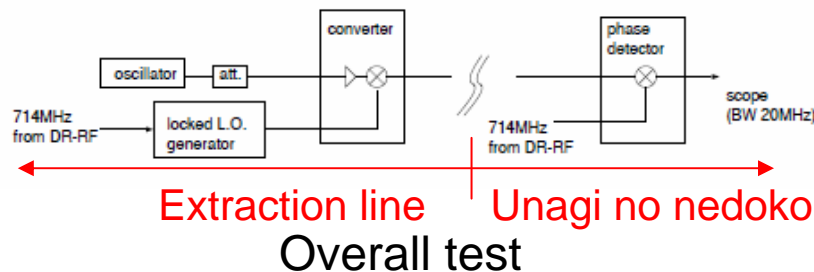

# Pulse shape

**Signal of the hot model shows low contamination without the unwanted modes.**

**Cold model (2006/6)**

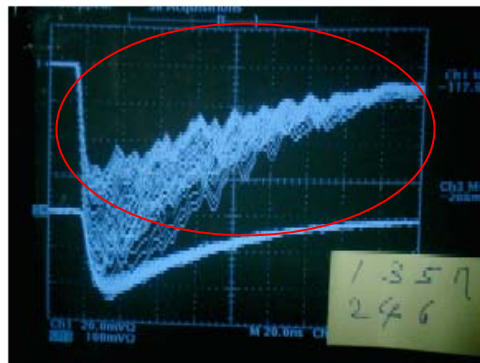

Without BPF

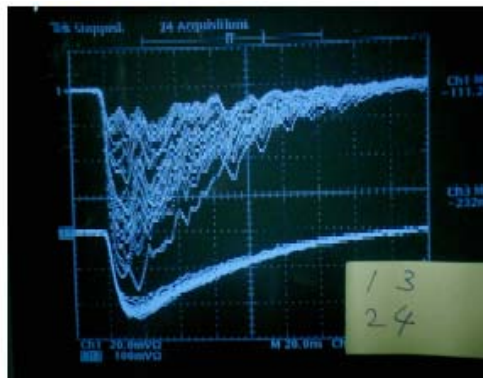

With BPF

- ☆ Strange pulse shape
- ☆ Signal seen at the center

↑ Modes other than di-pole mode originating from wave guides?



Changed wave guide design

**Hot model (2006/11)**

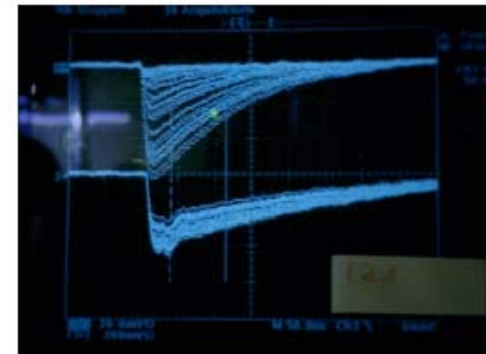

Without BPF

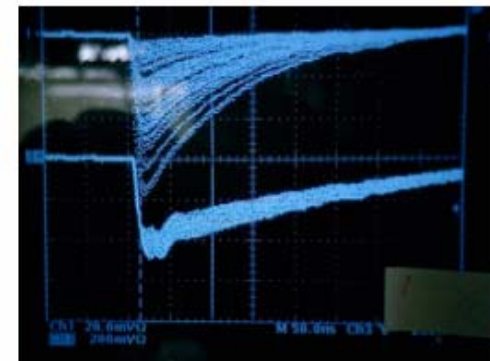

With BPF

# Position sensitivity

The position sensitivity of IP-BPM was  $\times 2$  higher than the ATF2-BPM in X direction,  $\times 3$  of the ATF2-BPM in Y direction.

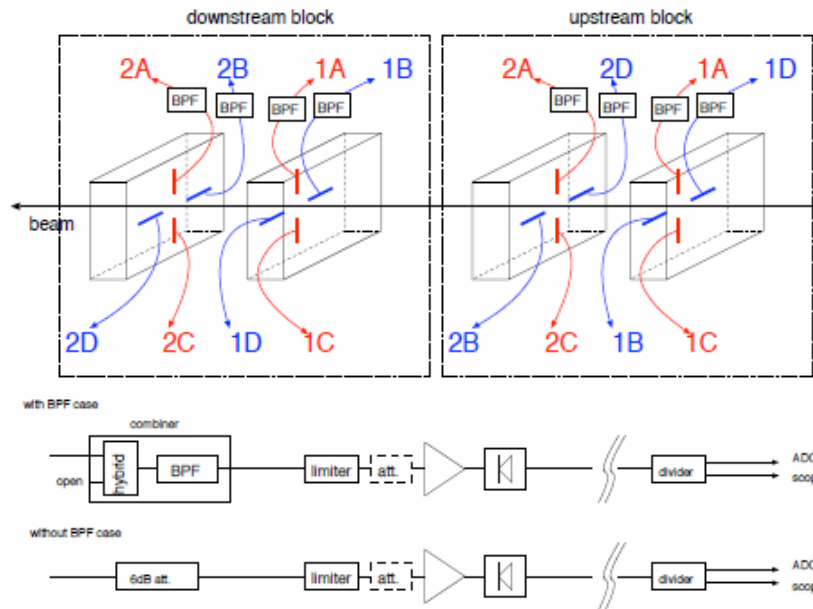

We checked the position sensitivity by sweeping the beam. We detected the position signal by diode.



图 5 Position Sensitivity Y-port

# Angle sensitivity

IP-BPM sensitivity to beam angle was  $1/2 \sim 1/4$  of the KEK-BPM. X mode 1.8 (mm/rad), Y mode 3.8 (mm/rad).

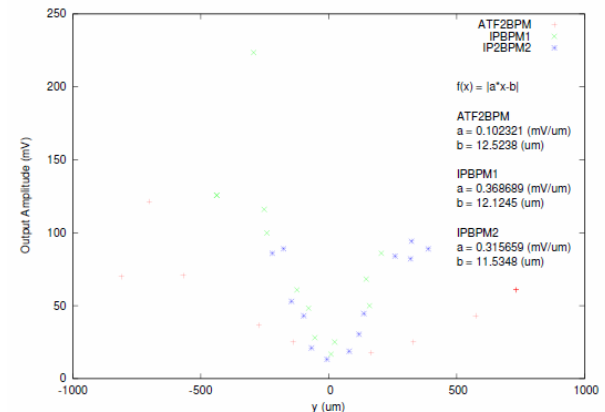
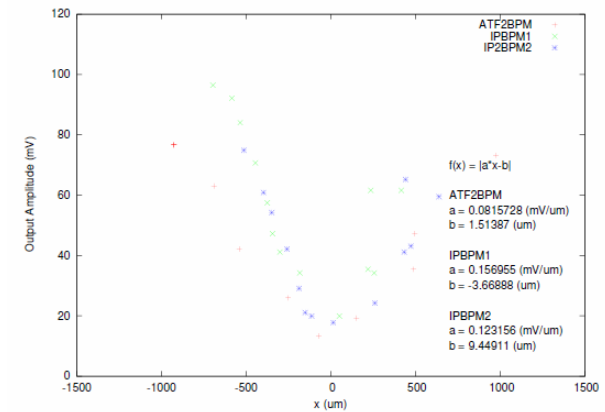
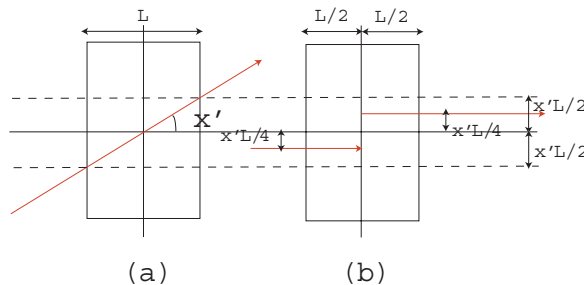

At the IP, an angle signal may excite di-pole mode even when it passes the cavity center. We must decrease angle sensitivity of the IP-BPM.

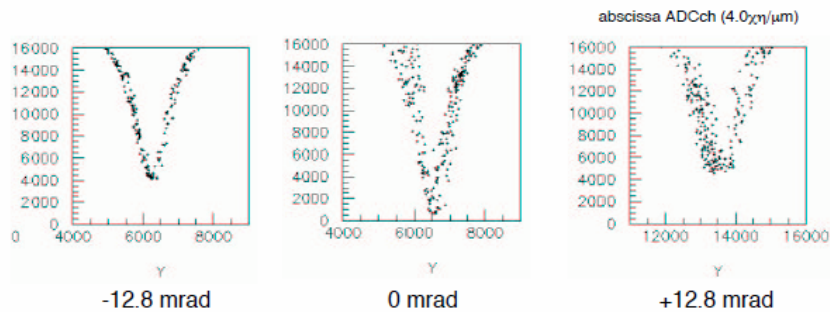
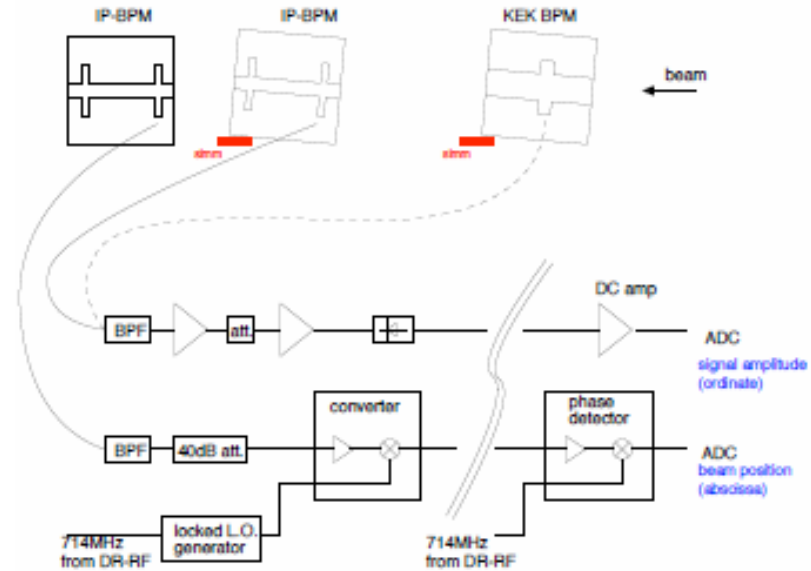

	Position equivalent to 1 [rad] signal By measurement (mm)	Position equivalent to 1 [rad] signal By simulation (mm)
KEK BPM	8.3	6.6
IP-BPM1 X	1.8	1.5
IP-BPM1 Y	3.8	2.6

# Position resolution

The resolution turned out to be over 2.7 nm, which show that we have achieved nm position resolution.

The limit of the position resolution is determined by the thermal noise.

$$V_{TN} = \sqrt{4kTZf_{BW}}$$

$$P_{TN} = kTf_{BW} > -109 \text{ dBm}$$

At room temperature,  $f = 3 \text{ MHz}$

Output amplitude would be,

$$V_{out} = \frac{\omega q}{2} \sqrt{\frac{Z}{Q_{ext}} \left(\frac{R}{Q}\right)} \exp\left(-\frac{\omega^2 \sigma_z^2}{2c^2}\right)$$

$$P_{out} = -90 \text{ dBm}$$

At  $Z = 50$ , Bunch Length = 8 mm,  
position offset = 1 nm

⇒ **nm resolution is possible**

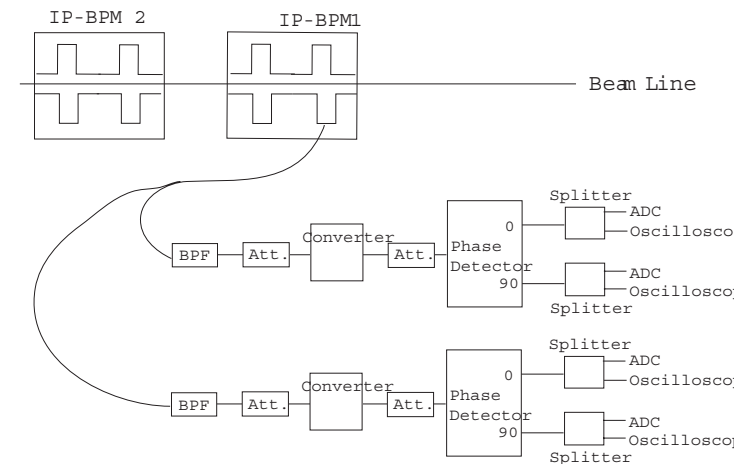

We divided the signal into two and used the same detecting electronic scheme. We can know the thermal noise and the limit of the resolution.

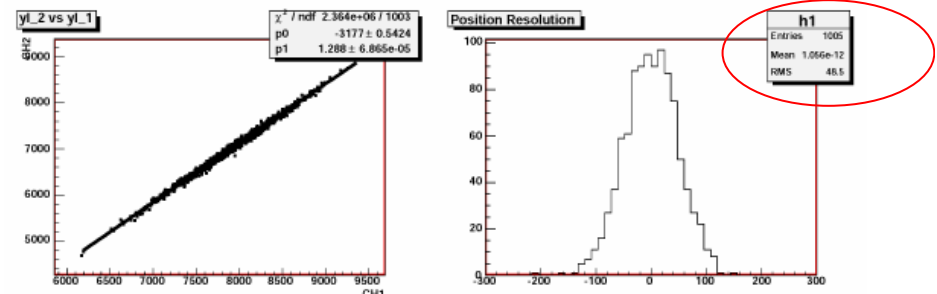

**1, Review**

**2, Current status**

 **3, Tasks ahead**

**4, Summary**



# Mover Tests

We plan to measure the IP-BPM position resolution by controlling the position in nano-meters by the piezo mover.

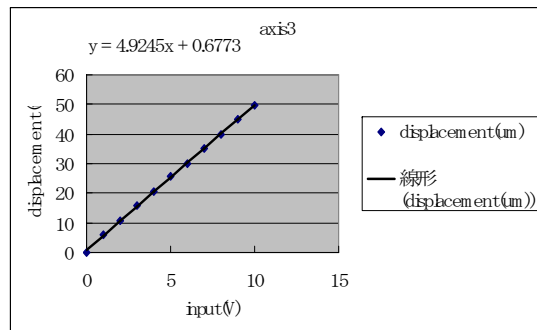
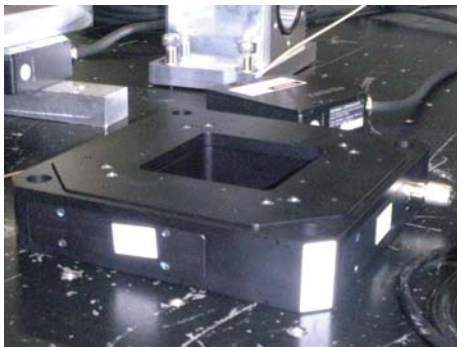

One cavity will be swept along x and y axis.  
Two cavities will be used for calibration.  
SLAC mover: for alignment  
Piezo mover: for calibration

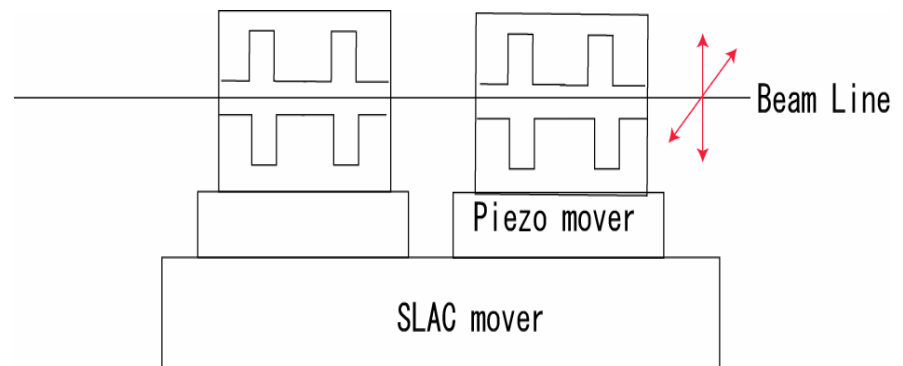

## ■ Piezo spec

- 1, Move in x, y, z directions independently
- 2, precision of nanometer order at maximum 50 μm
- 3, Capacitive sensor feedback system

# Bunch Length Monitor & Beam Charge Monitor

---

To monitor the beam position accurately, we must remove bunch length variation, beam charge variation, and so on . . .

☆ Bunch length  $\Rightarrow$  X Band cavity (11.424 GHz)

☆ Beam charge  $\Rightarrow$  S Band cavity (2.856 GHz)

☆ Beam charge & phase  $\Rightarrow$  C Band cavity (reference cavity)

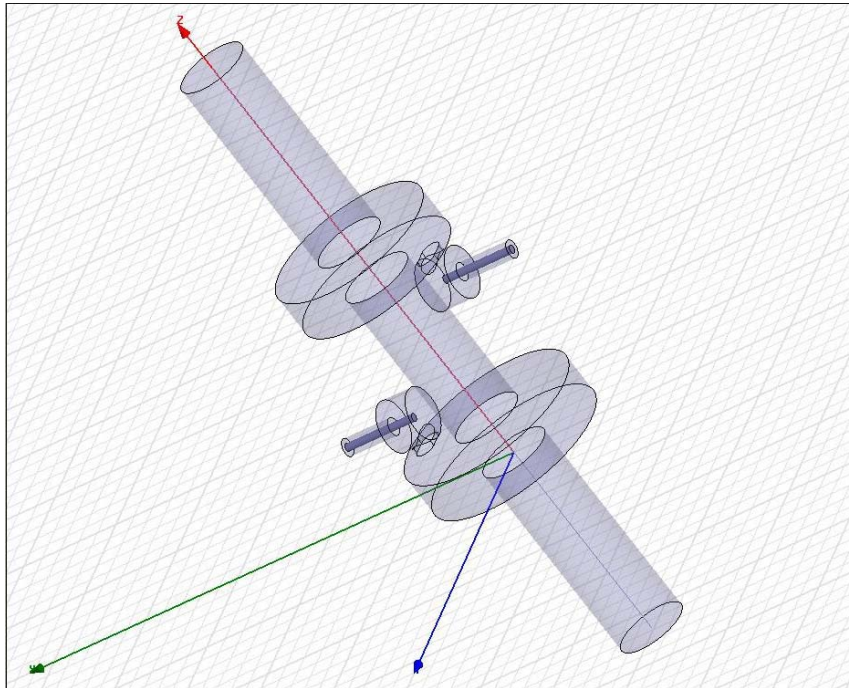

The monitors will be cylindrical, to read out mono-pole signals. The structure is same as the reference cavity.

# Tasks ahead

---

**2007. 1**

- SLAC mover
- Bunch length monitor, Beam charge monitor

**2007. 3**

- Position resolution measurement (mover test)
- Resolution conservation
- Collaboration with Shintake Monitor

**1, Review**

**2, Current status**

**3, Tasks ahead**

 **4, Summary**

# Summary

---

- IP-BPMs are fabricated as designed
- The nm position resolution (limited by thermal noise) is achieved
- Position resolution measurement using the mover is coming ahead (2007 spring)

**Thank you very much for your attention.**