



ILC Power Distribution

Status Presentation
Hamburg, May 2007
J. Pedersen
CERN



Status: Power Distribution

- **This presentation is an updated version of the one made in Valencia in November 2006.**



Status: Power Distribution

- Since Valencia, November 2006 the following has happened:
 - **The power needs of the project seems to stabilize around 230 MVA**
 - **The unit loads in certain areas are still to be defined in more detail to allow the Engineering Design to start**



Contents

- **Load schedule**
- **Network design**
- **The area systems**
- **Safe power systems**
- **Cost Reductions**



Load Schedule, User demands

- The users have analysed their load demands and have arrived at an overall load of around 230 MW.
- The breakdown of the load is only partially available and the location of the load elements is not developed. Work is needed here to allow the detailed Engineering Design to start
- **The Need for the integration studies of equipment to be installed in the limited underground space should not be forgotten!**



Load Schedule

AREA SYTEM	RF	CONV	NC MAGNETS	WATER SYSTEMS	CRYO	EMERG	TOTAL (by Area)	NOTES
SOURCES e-	1.05	1.19	0.57	1.27	0.46	0.16	4.7	Pre-Central DR-Loads Likely to Increase
SOURCES e+	4.11	7.32	6.52	1.27	0.46	0.54	20.2	Pre-Central DR-Loads Likely to Increase
DR	14.00	1.71	6.78	0.66	1.76	0.60	25.5	RF / NC Magnets / Cryo per Central DR Other Loads Indicated Pre-Central DR
RTML	7.14	3.78	2.84	1.34	0.00	0.40	15.5	Pre-central DR-Loads
MAIN LINAC	75.72	13.54	1.41	9.86	33.90	1.03	135.5	
BDS	0.00	1.11	18.48	3.51	0.33	0.52	24.0	
DUMPS	0.00	3.83	0.00	0.00	0.00	0.31	4.1	
TOTAL (by System)	102.0	32.5	36.6	17.9	36.9	3.6	229.5	MW



Load Schedule

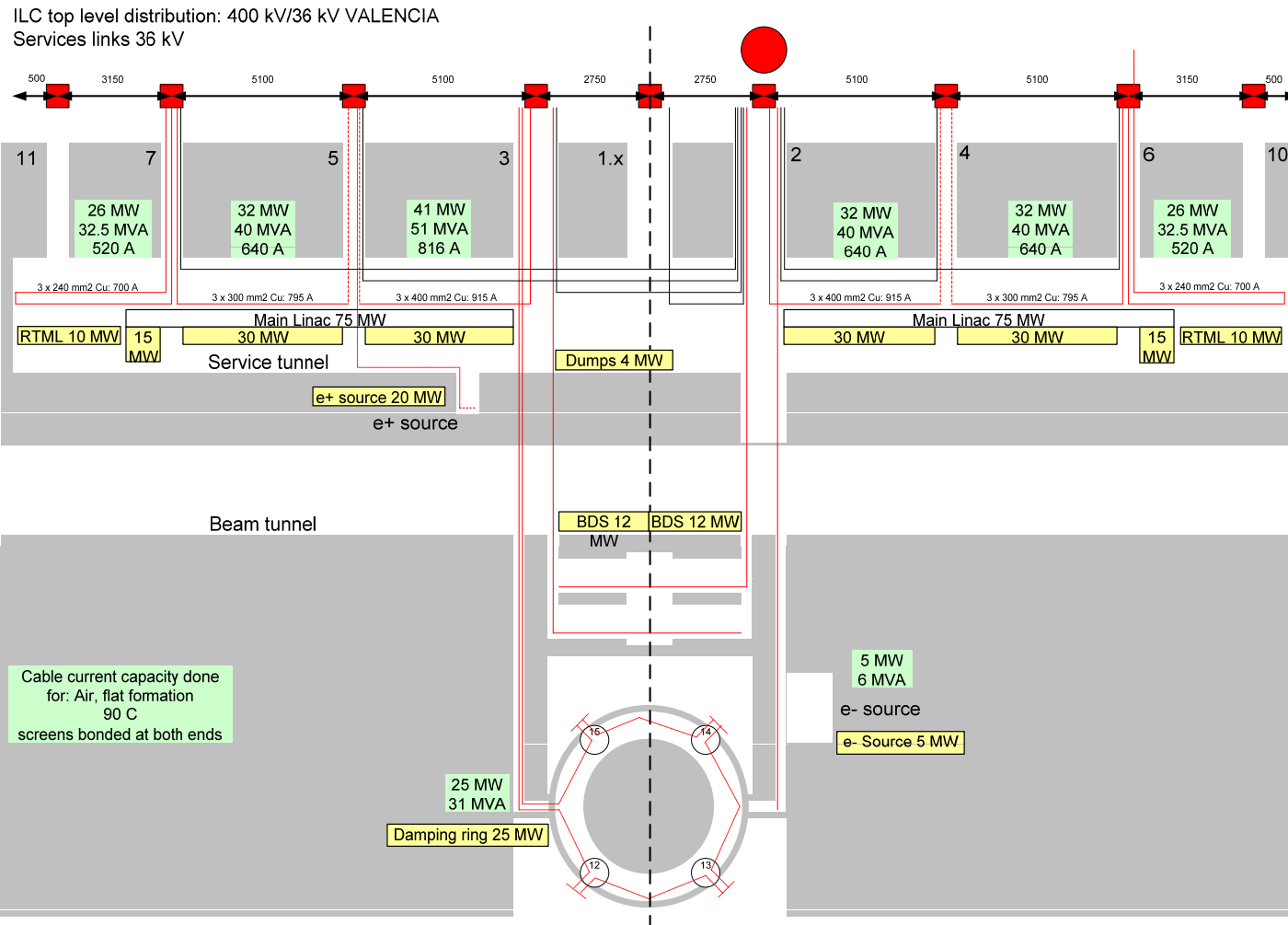



Network Design

- The retained voltage levels are (European site) :
 - **Grid connection: 400 kV**
 - **Energy transport to the pits and access areas (Distribution substations): 36 kV**
 - **Energy distribution in the areas: 36 kV**
 - **3.6 kV for large motor-compressor sets (> 400 kW; cryogenics?, chillers?)**
 - **3.6 kV for the safe power transport**
 - **Local distribution to the general user: 400/230 V**
- Regional differences will exist. They are considered of limited importance for the design and the cost.



Network Design

- The center of the network will be the main substation, containing (European site):
 - **One bay for the connection to the grid**
 - **Four transformer bays: 400/36 kV**
 - **Four 36 kV bus-bars, interconnected with bus-ties, allowing operation with one transformer failed.**
- A simple lay-out of the main sub-station is shown in fig. 1



Network Design

- Central substation 400/36 kV

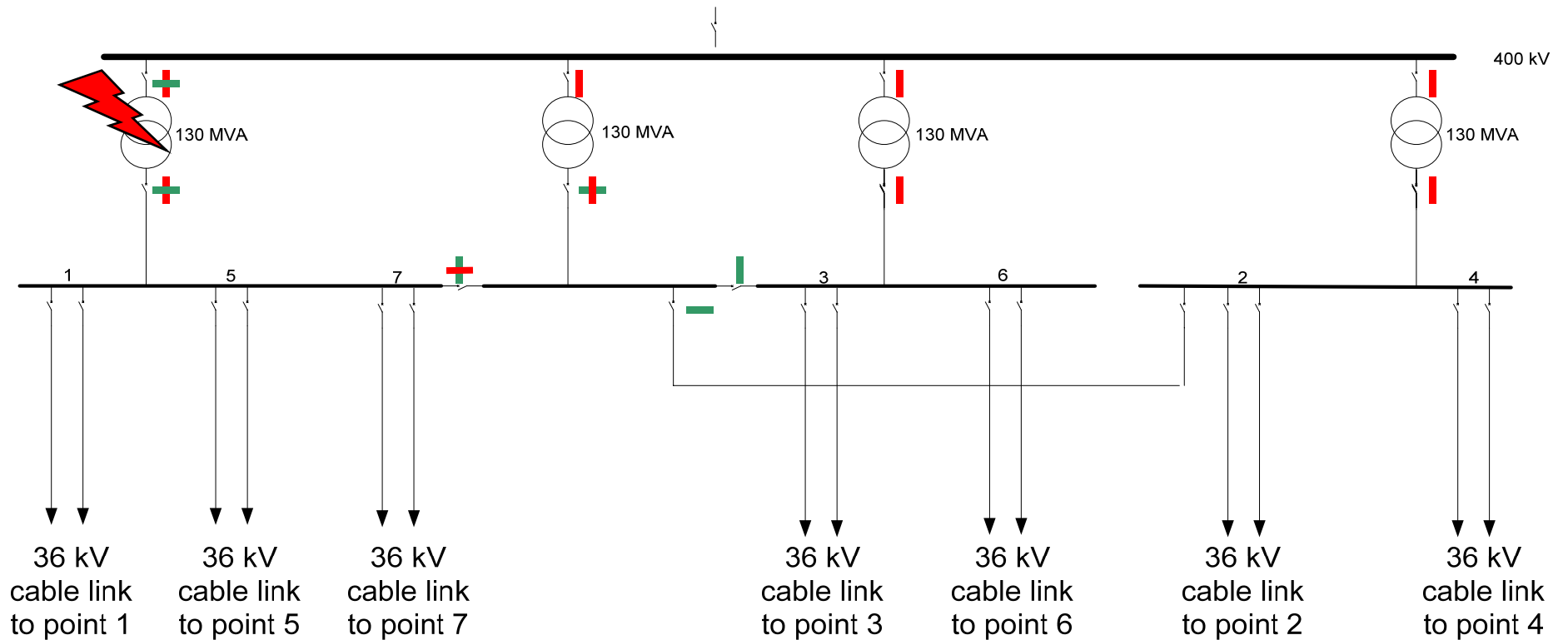



Network Design, Power Ratings

- The total power, demanded by the users (RDR) is 230 MW
- Then the power rating of the transformers would depend on the power factor:
 - $PF = 0.80 \Rightarrow 288 \text{ MVA}$
 - **$PF = 0.85 \Rightarrow 270 \text{ MVA}$**
 - $PF = 0.90 \Rightarrow 256 \text{ MVA}$



Network design

- Prudence will that the transformer rating is selected at 110 MVA per unit minimum.
 - (1770 A, well within the limit for standard 36 kV equipment: 2500 A)
- This represents a reserve of roughly 20% with respect to the load, at $\cos\phi_i = 0.85$.
- It is proposed to invest in a hot spare - kept under voltage, possibly in operation - i.e. four units in total.
- 110 MVA units can be easily manufactured and transported as three phase units. Road transport is feasible



Network design

- The main substation will have four 36 kV bus-bars. Each of the three active transformers will feed one of them.
- The distribution substations in the access areas will be fed from the main sub-station by 36 kV cable links.
- The cables are laid in open loop configuration. This gives added operational flexibility in case of equipment failure in the top level power distribution.



Network Design

- **Open loop**

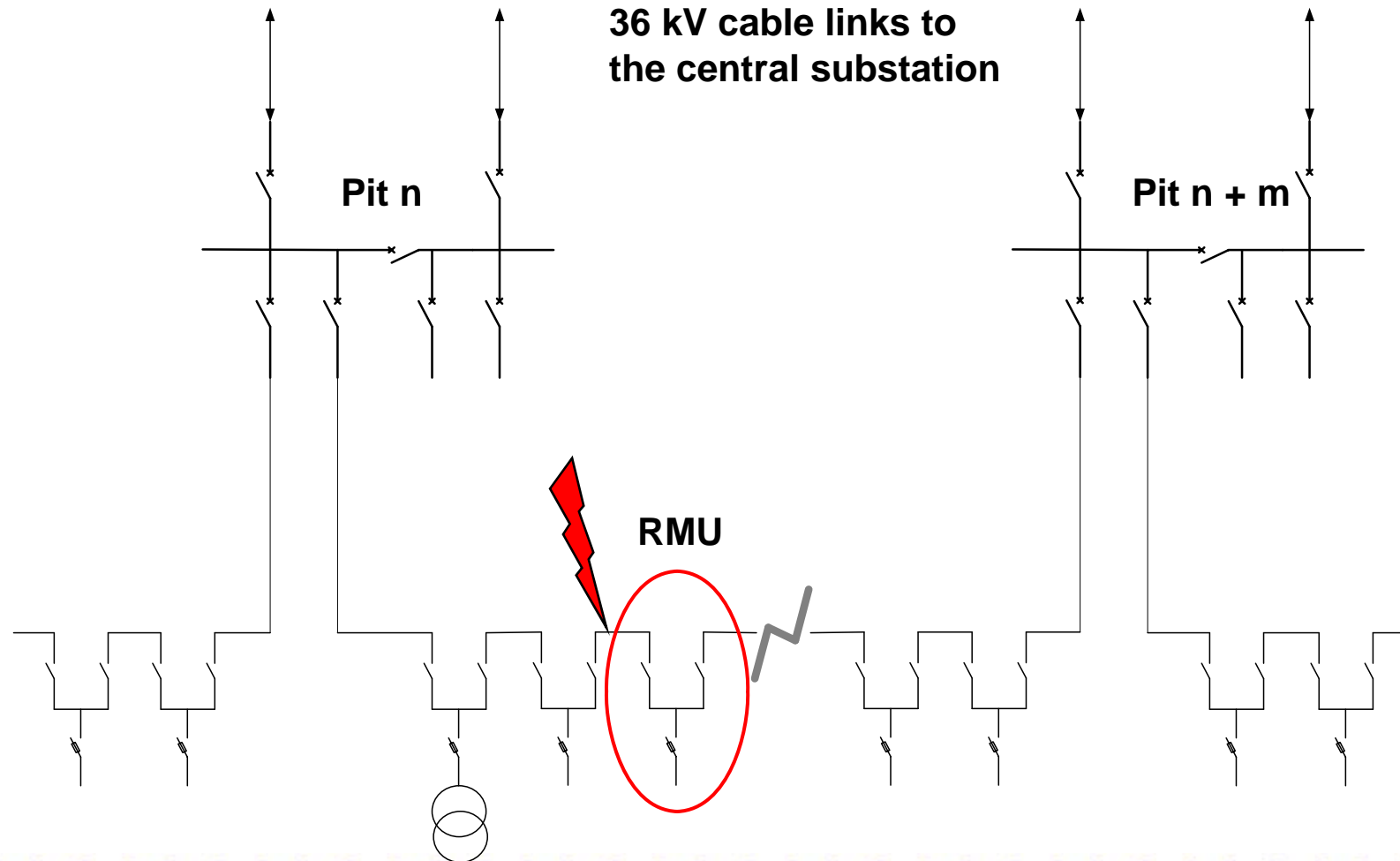



Network design

- The 36 kV cables will be run in the service tunnel.
- They will run on cable ladders, equipped with perforated covers. This will provide mechanical protection.
 - **European version; regional differences may exist here.**
- In the central area, between pit 2 and 1, up to 8 sets of three single core cables may be routed in the tunnel.
- Over the major part of length of the Linac it will be 2 sets plus one, for the emergency supply, running in the service tunnel.



Available short circuit power

- The short circuit power with this solution will vary from around 200 MVA on the 36 kV busbar in the furthest pit to around 675 MVA on the 36 kV busbar in the central substation.
- These values can be influenced by the transformer design and the cable cross section.
- During the engineering design the voltage drops in the system downstream in the furthest points should be given attention.



Network design

- The distribution substations will comprise two 36 kV switchboards, made up of 36 kV modular switch gear
 - **One for machine supply**
 - **One for services**
- Each switchboard will have voltage monitoring
- The two switchboards will be interconnected by a bus-tie.



Network design

- Each feeder will be equipped with the relevant protection equipment, able to perform protection, measurements, logical sequences for interlocks etc. and oscillographic event recording.
- The next four figures show single line diagrams of the substations of pits 2, 4 5 and 12.



Network design

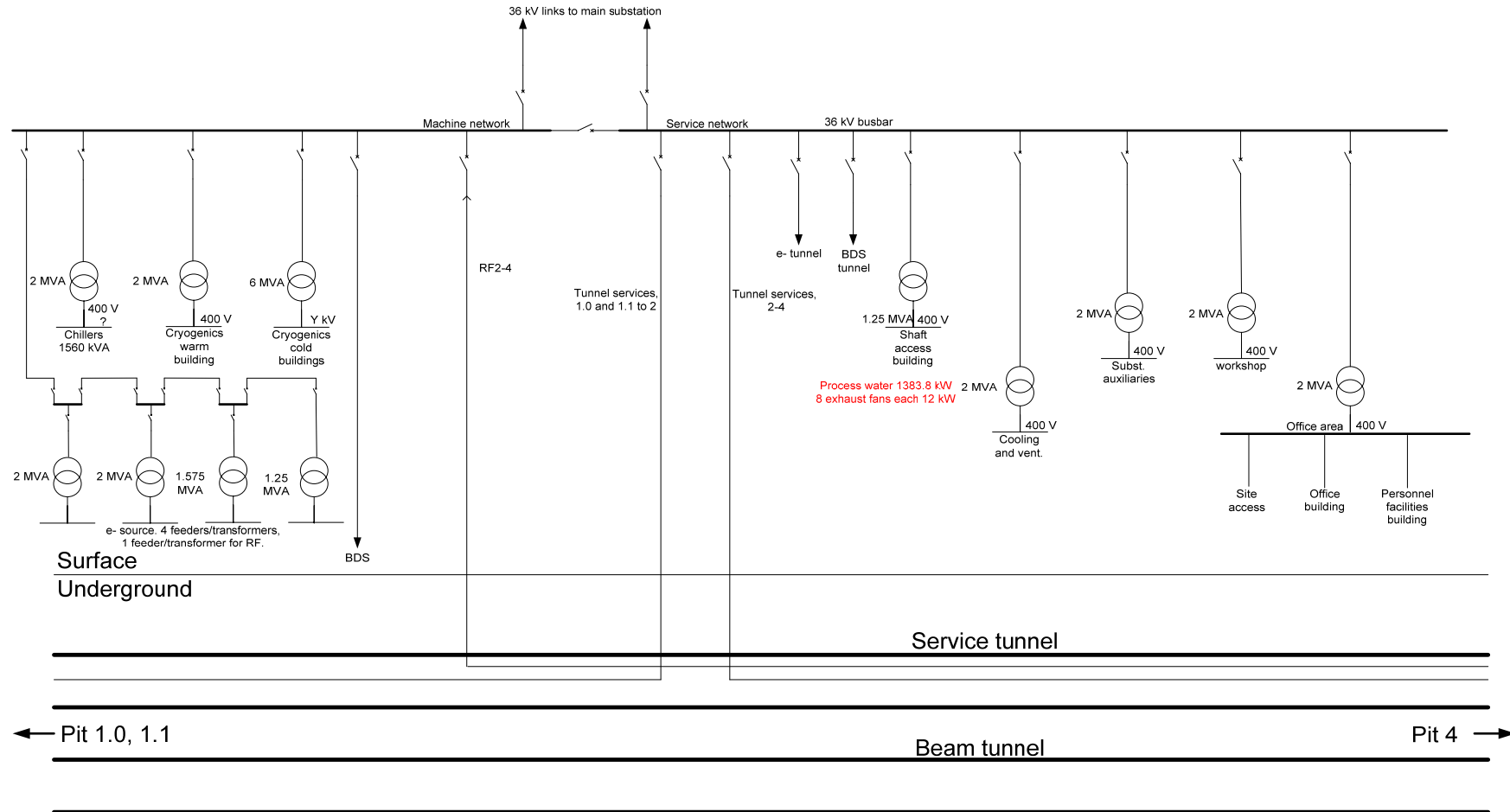

Substation pit 2, Main Linac, e- source



Network design

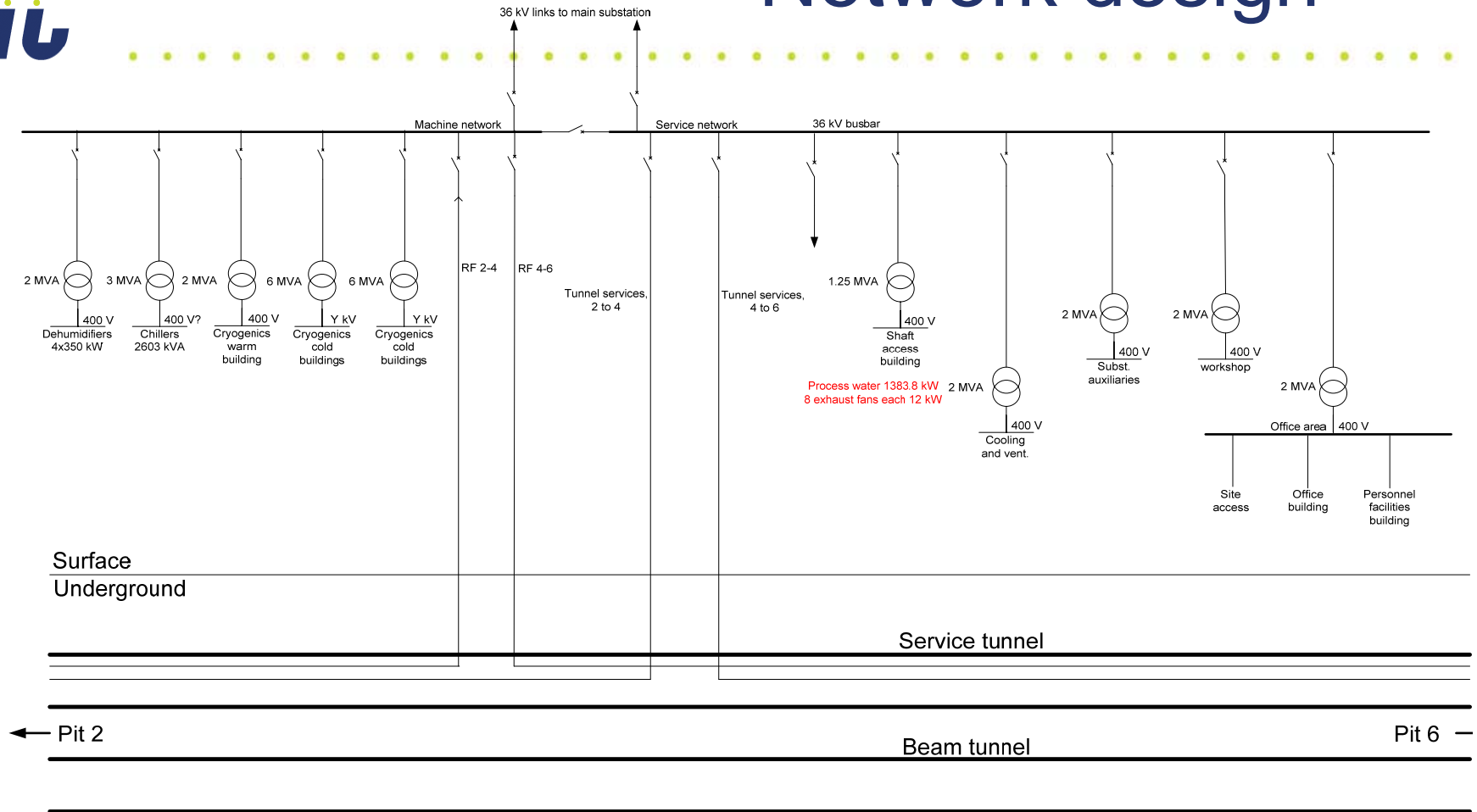

Substation pit 4, Main Linac



Network Design

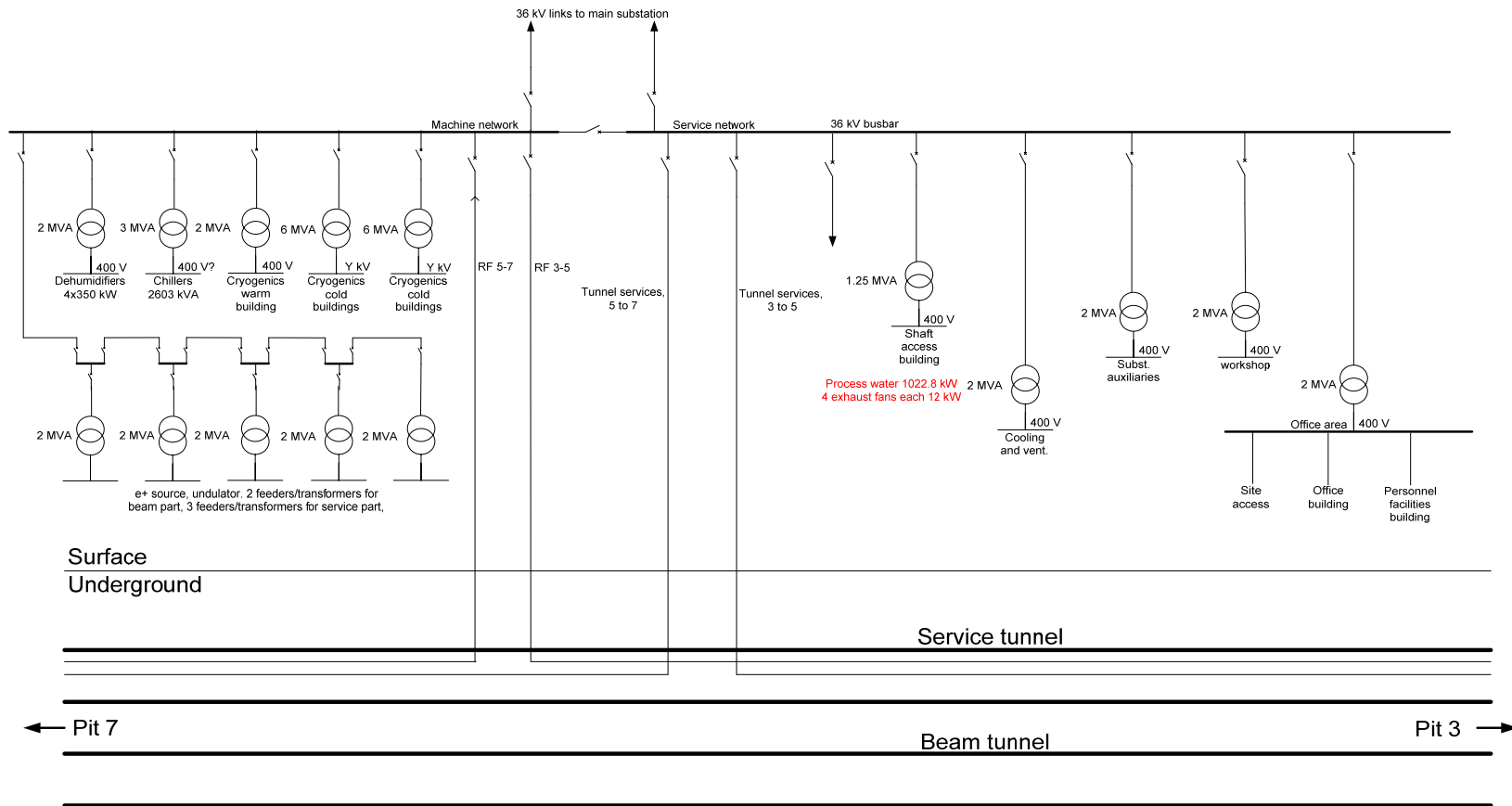

Substation pit 5, Main Linac, e+ source



Network Design

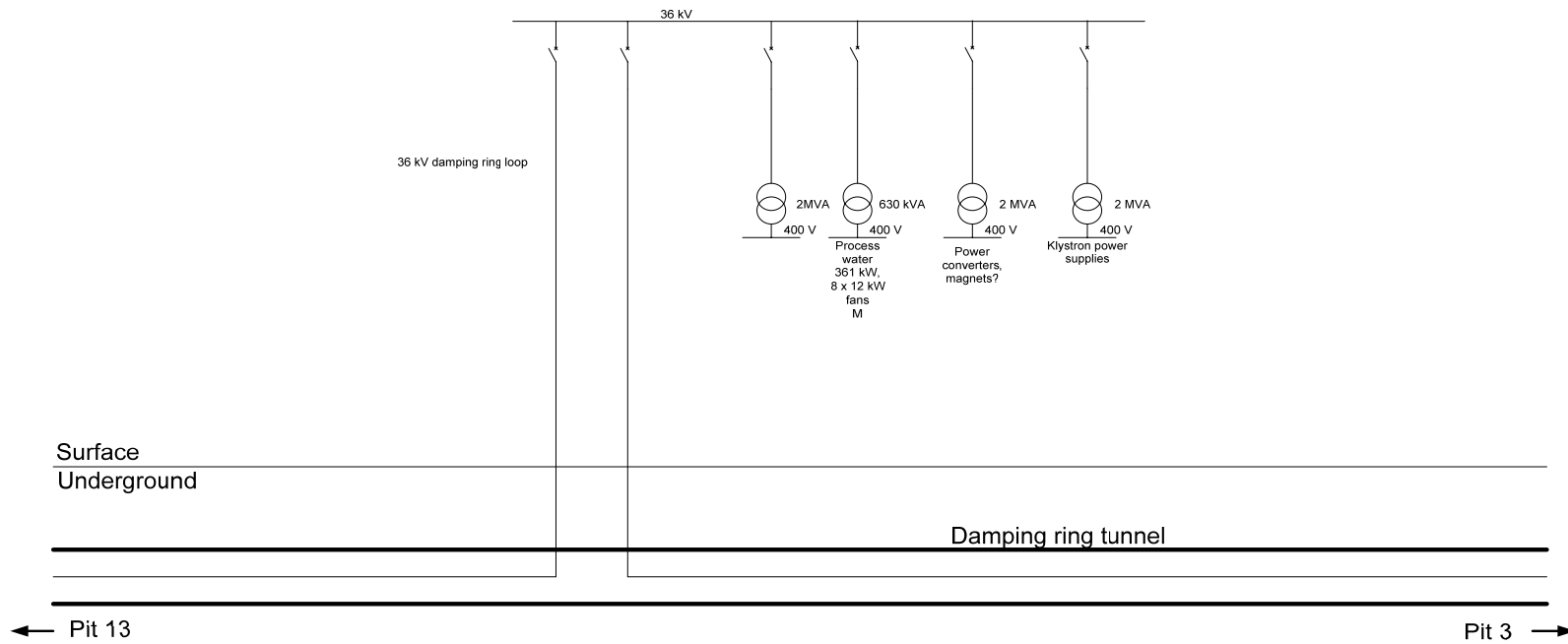

Substation Pit 12, Damping ring



Network design

- The power distribution in the tunnels will be based on 36 kV cable links, distributing via Ring Main Units and local distribution transformers: 36 / 0.4 kV. The local distribution will be 400/230 V three phase.
 - **European version; regional differences may exist.**
- The 400/230 V cabling will be five-wire, including neutral and PE, except specific cases where only three phase systems are supplied; f. ex. power converters.
 - **Regional differences may exist, depending on standards.**



Tunnel High Voltage

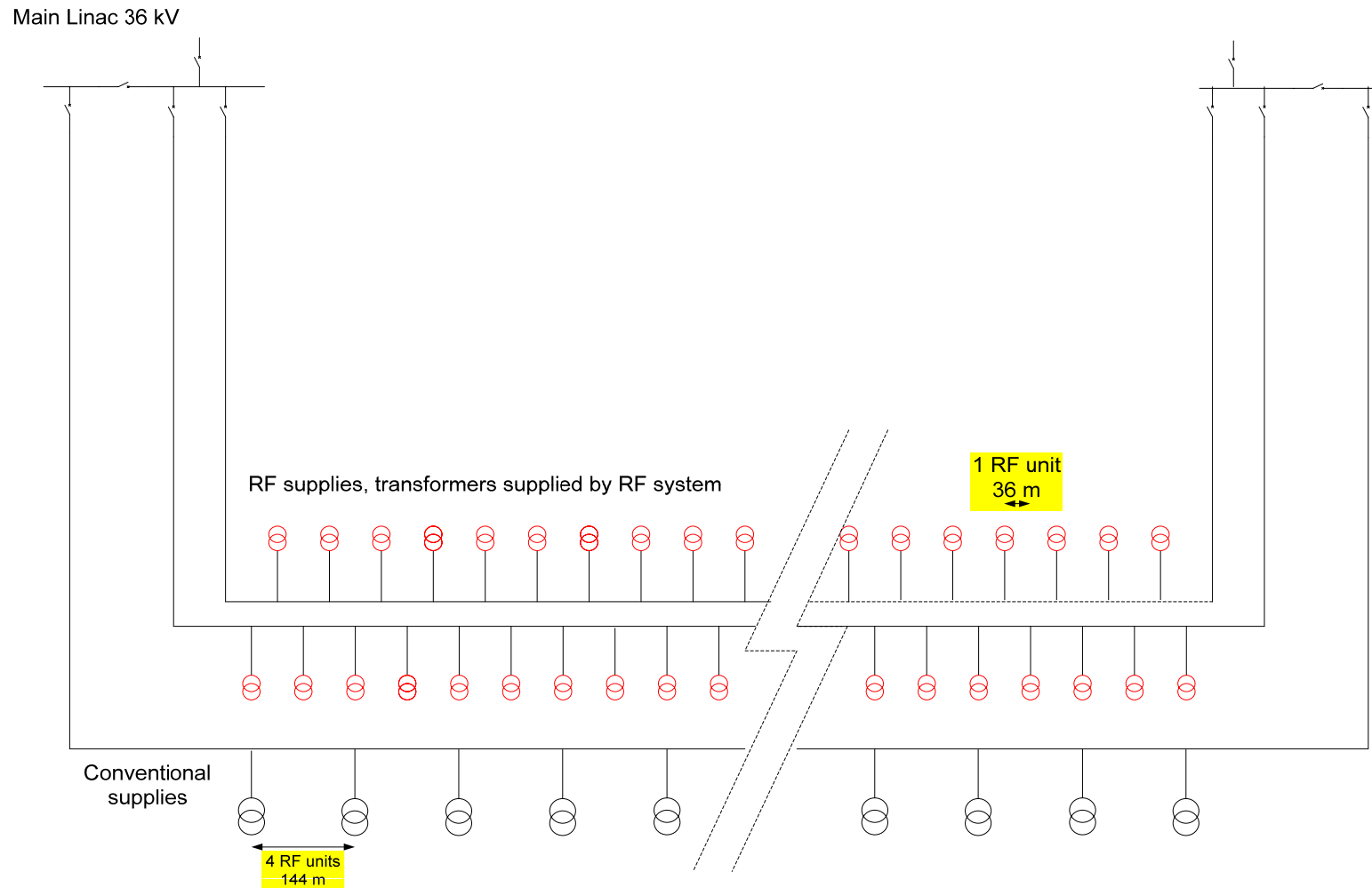



Tunnel High Voltage

Ring Main Unit 36 kV
CAS-36

Presentation and characteristics

Symbols

Network switch disconnector

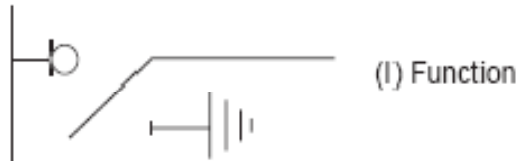

Transformer feeder fuse switch combination

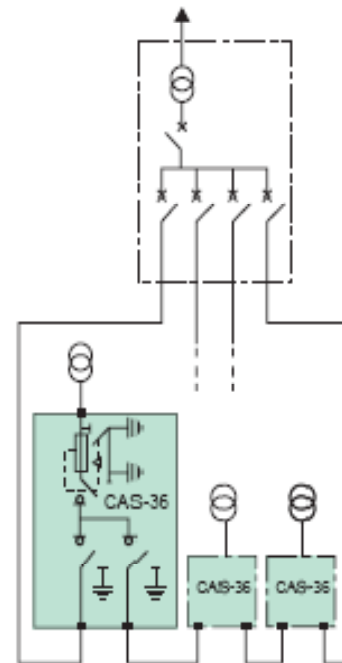
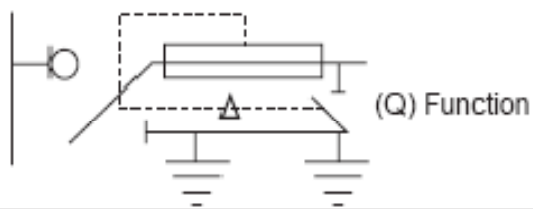



Tunnel High Voltage

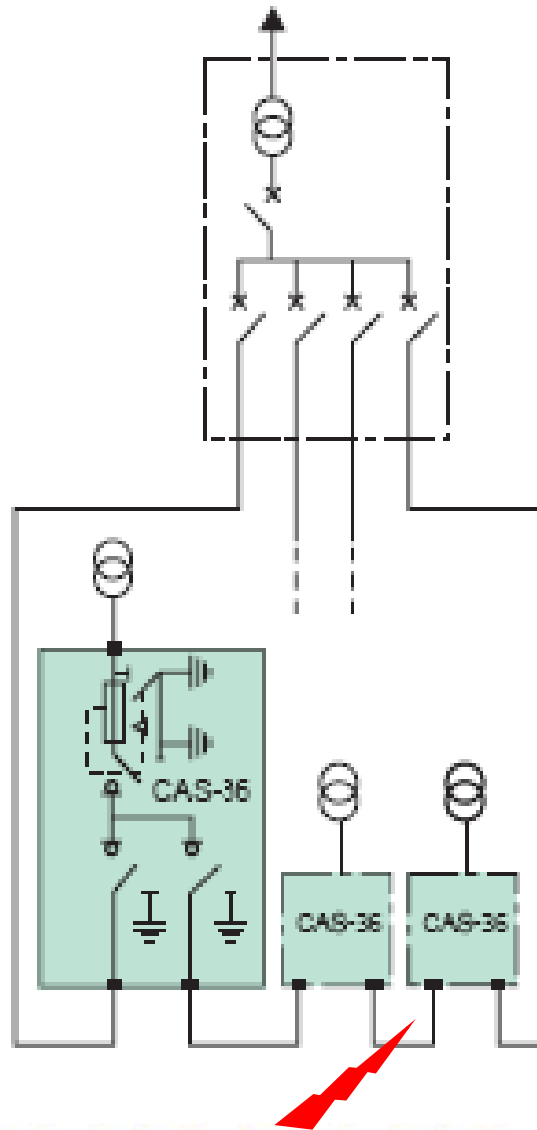



Tunnel High Voltage

Dimensions and weights

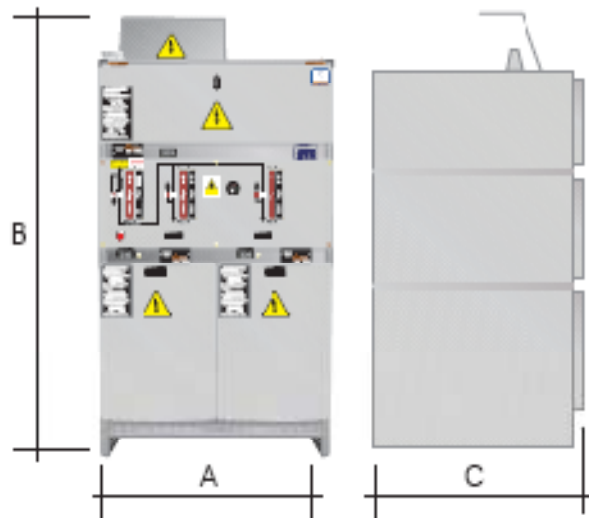

CAS-36 Type	Width A (mm)	Height X ^B (mm)	Depth C (mm)
CAS-36 3I	1050	1850	1005
CAS-36 4I	1200	1850	1005
CAS-36 2I+Q	1050	2000	1050
CAS-36 2I+2Q	1200	2000	1050
CAS-36 3I+Q	1200	2000	1050



Tunnel High Voltage

Electrical characteristics

Rated voltage (kV)	36 kV	
Insulation level		
Industrial frequency 50 Hz 1 mm (kV rms)	70 kV	
Impulse 1.2/50 ms (kV peak)	170 kV	
Network switch disconnecter		
Rated Current (A) ⁽¹⁾	400 A / 630 A	25 – 39 MVA
Breaking capacity (A) ⁽¹⁾		
Normal load current	400 A / 630 A	
Earthing fault	50 A	
Off-load cable	25 A	
Short-time (1 s) withstand network current (kA rms)	16 kA / 20 kA	
Making capacity of switch-disconnector and earthing switch (kA peak)	40 kA / 50 kA	
Endurance		
Electrical endurance	100 CO cycles at rated current (630 A) and 0.7 p.f.	
Mechanical endurance	1000 mechanical opening operations.	
Internal arc	(16 kA / 1 s) / (20 kA / 0,5 s)	
Transformer feeder fuse-switch combination disconnecter		
Rated current (A)	200 A	
Fuse-switch		
Short-circuit breaking capacity (kA) ⁽²⁾	(2)	
Making capacity (kA peak) ⁽²⁾	(2)	

(1) In accordance with IEC guidelines, these characteristics are valid for ambient temperatures of between -15 °C and +40 °C (class -15 °C). For higher temperatures, please contact us.

(2) Limited by the fuse.



Tunnel distribution

Lay-out of the supply for a 144 m tunnel segment

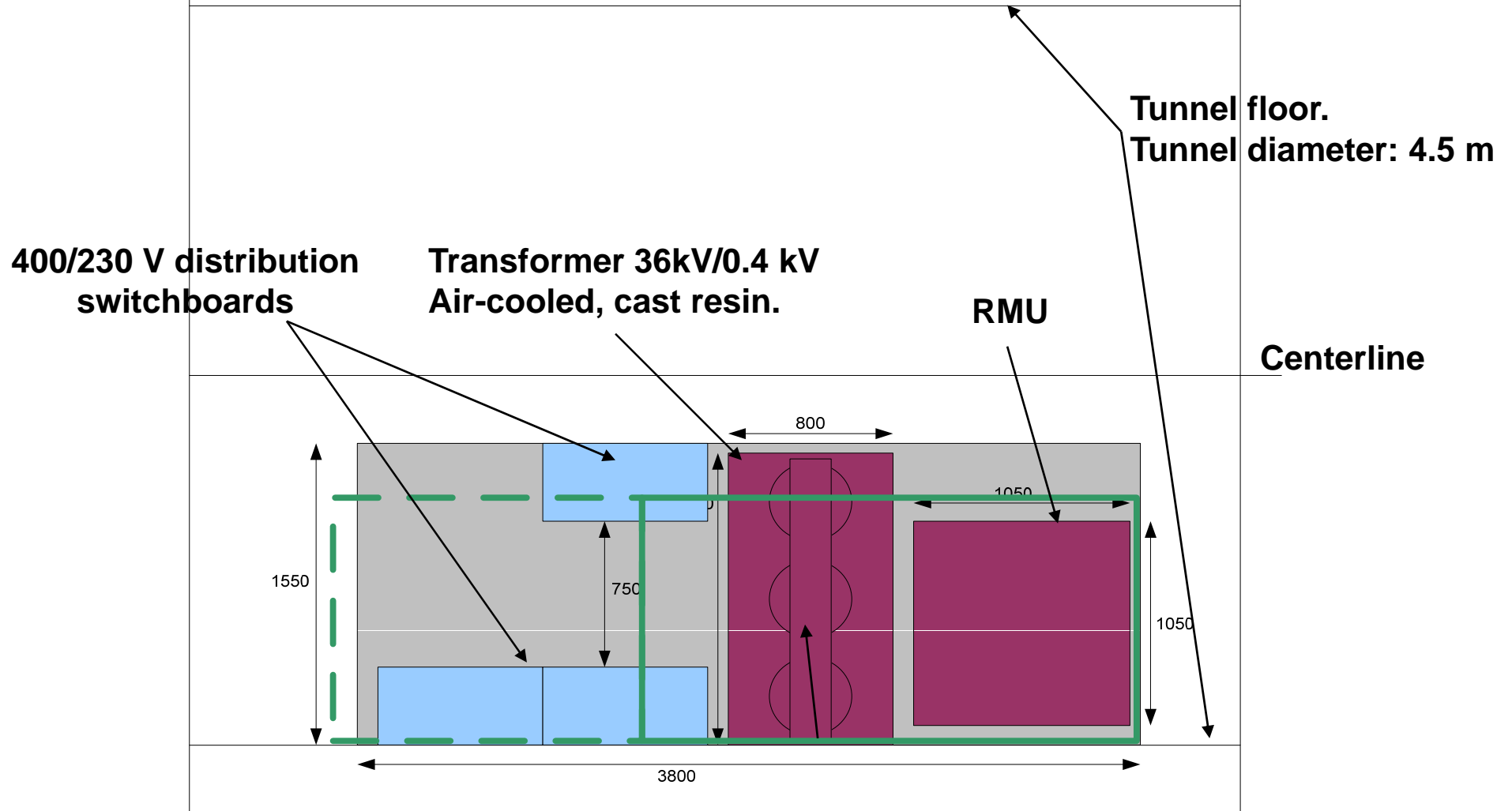



Tunnel Distribution

An RMU in a 4.5 m tunnel

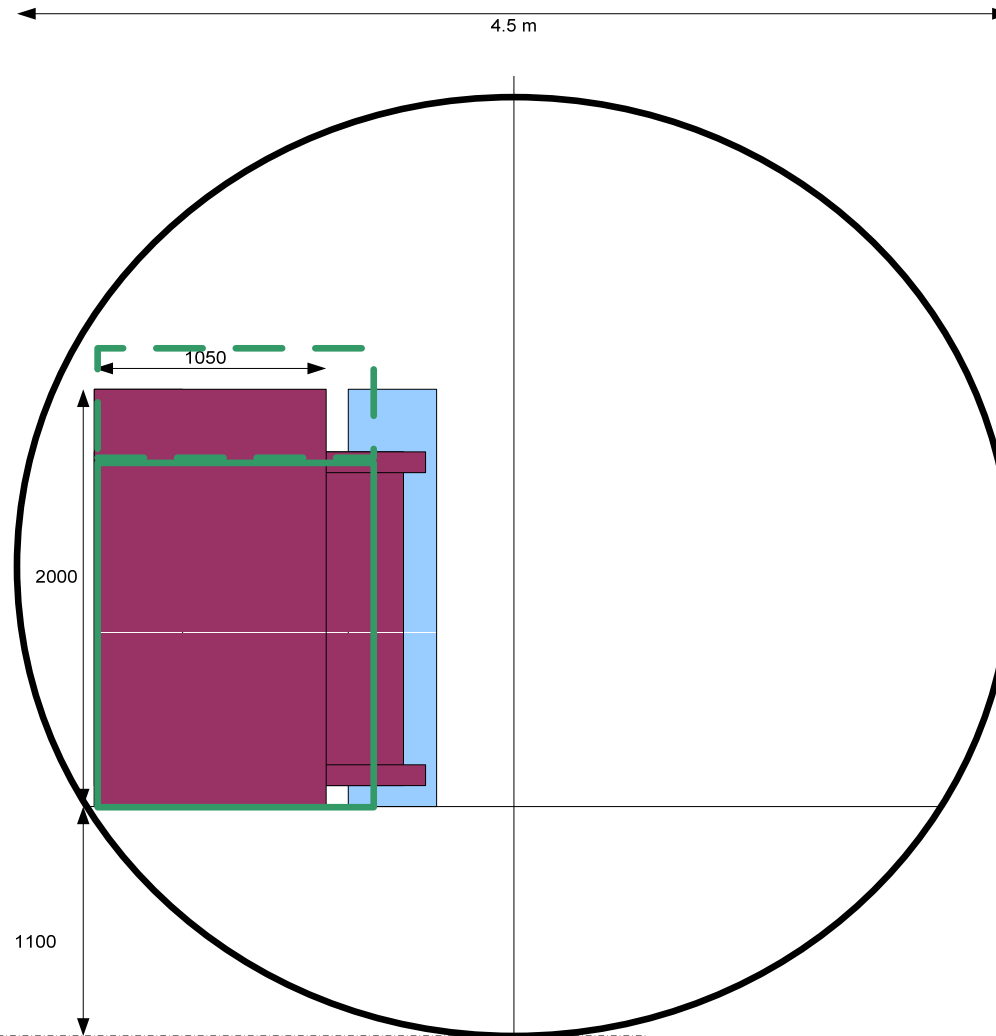



Tunnel distribution

- Auxiliary voltage
 - **The equipment in the tunnel will most likely need an auxiliary voltage: 48 V D.C.**
- This voltage cannot be transported reasonably over large distances;
 - **Voltage drop versus cable section**
- Alternative:
 - **Produce 48 V at every 144 m, including batteries! Reliability, maintenance (Approximately 170 sources.)**
- **To be looked into during engineering design**



Network design

- Each distribution substation will comprise a complete 48 V supply with battery back-up for the safety systems:
 - **The protection equipment of the H.V system**
 - **Trip coils and other auxiliaries of the H.V. and L.V. switchgear**
 - **Emergency lighting**
 - **Emergency stop systems**
 - **Power network SCADA system**
- The 48 V supply will have two battery chargers, two 48 V distribution switchboards with a bus-tie and two batteries, NiCa. These installations shall be backed up by the diesel gen. sets



Tunnel distribution

- Thermal considerations
- The switchgear, transformers and cables all dissipate heat in the tunnel.

– Typical values:

- RMU: **RMU**
- 400 V switchgear: 1 kW per column, rated load
- 500 kVA transformer:
 - No load losses: $P_o = 2$ kW
 - Load losses: $P_{Cu} = 6.5$ kW
- Cables: **?**

– Per 144 m module: (**RMU + 8.5 + 3 + ?**)kW



Network design

- Interface to the other systems
 - **Where does the cost and responsibility of the A.C. power distribution stop?**
- Example, sub-distribution:
 - **The limit of the responsibility of the A.C. distribution is the end of the cable reaching a sub-distribution board installed by another team. The distribution internal to the sub-distribution is the responsibility of the relevant team.**



Network design

- Example, cooling skid:
 - **The limit of the responsibility of the A.C. distribution is the end of the cable reaching a cooling skid. Any distribution internal to the skid is the responsibility of the cooling team.**
- Example, cryogenic motor-compressor set:
 - **The limit of the responsibility of the A.C. distribution is the end of the cable reaching the connection points of the motor. Any distribution internal to the compressor set is the responsibility of the cryogenics team.**



Network Design

Shaft 5, cooling and vent.

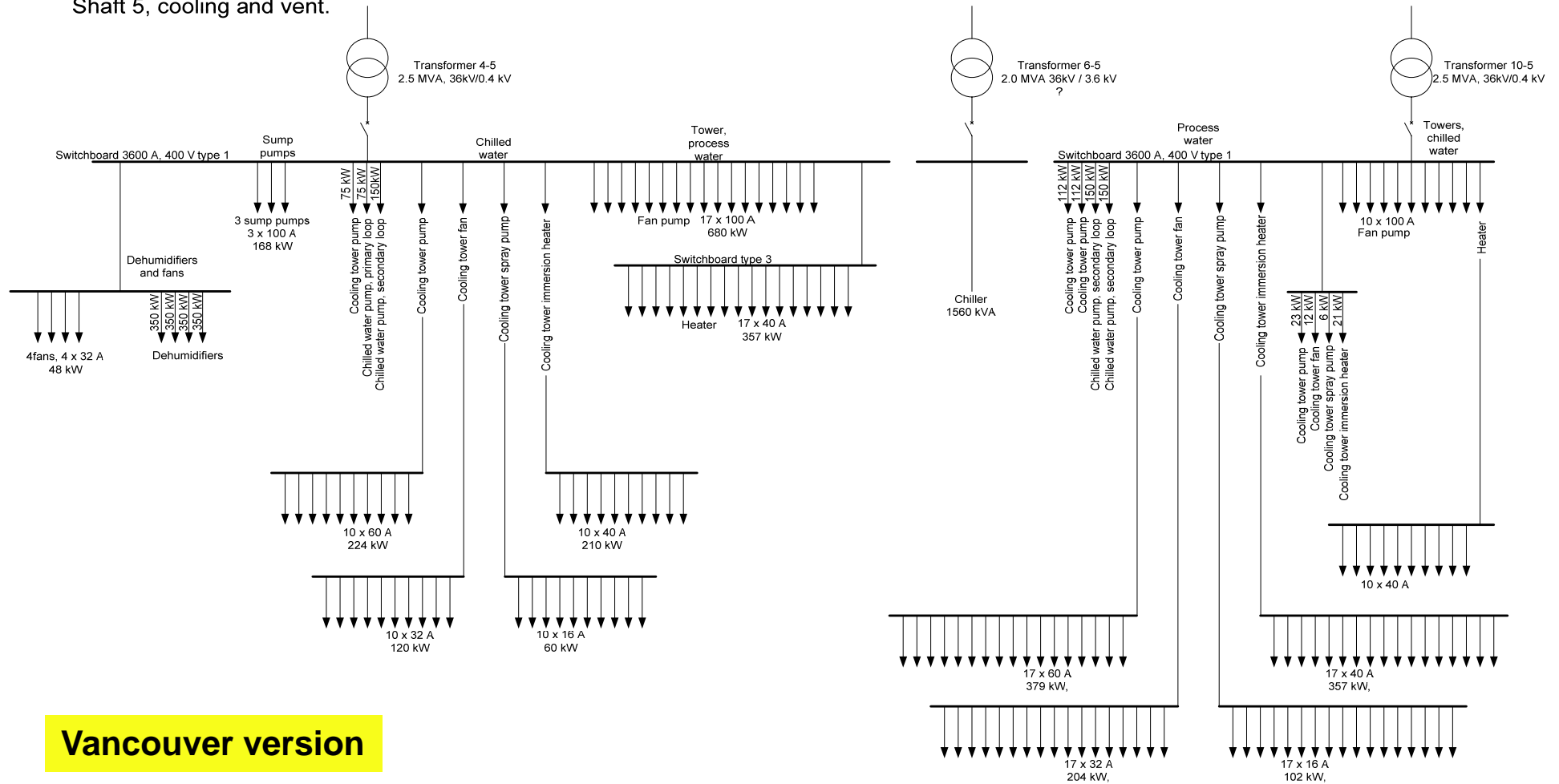

Vancouver version



Main Linac

- The power distribution of the Main Linac consists of three major systems:
 - **The conventional services supply**
 - The services will be supplied from a 36 kV cable link with RMUs inserted every 144 m, or every 4th RF unit. A 500 kVA, 36/0.4 kV transformer and a switchboard will handle all conventional power in a 144 m module.
 - **The RF supply**
 - Only a 36 kV cable link and the RMUs will be provided.
 - **The safe supply**
 - Based on diesel generator sets and, possibly static UPS systems. Still to be defined in detail.



Main Linac

- The conventional services supply
 - **The services will be supplied from a 36 kV cable link with RMUs inserted every 144 m, or every 4th RF unit. A 500 kVA, 36/0.4 kV transformer and a switchboard will handle all conventional power in a 144 m module.**
 - The overall non-RF load is approximately 70 MW
 - Applying $PF = 0.85$ we get 82 MVA.
 - There are 157 modules of 144 m.
 - Per module the non-RF load is thus 520 kVA.
 - A 500 kVA transformer has been foreseen.
 - A bit of fine tuning will be needed.



Main Linac

- Power needs of 144 m Main Linac tunnels, according to criteria sheet
- Beam tunnel
 - **Cryogenic module with quad?, (power conv.)**
 - Cryogenic module without quad?
 - **Cryogenic auxiliaries?**
 - **Vacuum system? (pumps. f. ex.)**
 - **RTML quads? (new)**
 - **Socket outlets**
 - **Lighting**
 - **Water?, HVAC?, Drain and sump?**
 - **Other utilities?**
 - **Transport?**



Main Linac

- Power needs of 144 m Main Linac tunnels, according to criteria sheet
- Service tunnel
 - **RF racks: 45 kVA**
 - **Other racks: 45 kVA**
 - **Socket outlets**
 - **Lighting**
 - **Water (process), water (chilled), pumps etc.?**
 - **Water (de-mineralised)**
 - **HVAC? Drain and sump?**
 - **Transport?**
 - **Other utilities**



- From the power distribution point of view the 1330 m long RTML areas are like the LINAC-like 144 m modules:
 - **730 m or 5 x 144 m of them with RF**
 - **600 m or 4 x 144 m of them without**
 - **The conventional services are considered largely identical**
- The detailed development of the power distribution of the RTML areas will require a better knowledge of the lay-out, or integration of the equipment.



RTML

- The long low-energy beam lines, part of the RTML have not yet been taken into account by the A.C. distribution.
- According to the RTML people, each quad has to be fed from an independent P.C.



Source e-

- The power demands for the e- source are rather well defined.
 - **A H.V. distribution is proposed for the area.**
 - **The costing based on the criteria sheet was developed for Vancouver, incl. a tentative L.V. distribution.**
 - **The e- source installation needs a clear definition of the interface and a lay-out to be able to identify the unit loads and their position**



- **A preliminary proposal has been made for the e+ source.**
 - **A H.V. distribution is proposed for the area.**
 - **It covers in some detail the Undulator area.**
 - **The power distribution of the rest of the e+ source system has been estimated as place holder**
 - **The costing based on the criteria sheet was developed for Vancouver, incl. a tentative L.V. distribution.**



Damping rings

- The power distribution in the damping ring tunnel will be based on a 36 kV cable loop. **Or two?** The loop will be designed to operate open. The loop will allow best possible isolation of faults.
- The loop will originate from the Central area surface substation and will be brought to the surface at all damping ring pits. There it will supply, via a 36 kV/0.4 substation, the surface area and the underground installations.



Damping rings

- The low voltage power lines for conventional services will originate from the alcoves. The lines should not be longer than around 600m. Otherwise it becomes difficult to design the lines with a proper protection.
- It is not possible to operate with RMU-like systems in the DR tunnel, due to the limited diameter.



Damping rings

Lay-out of an alcove substation.

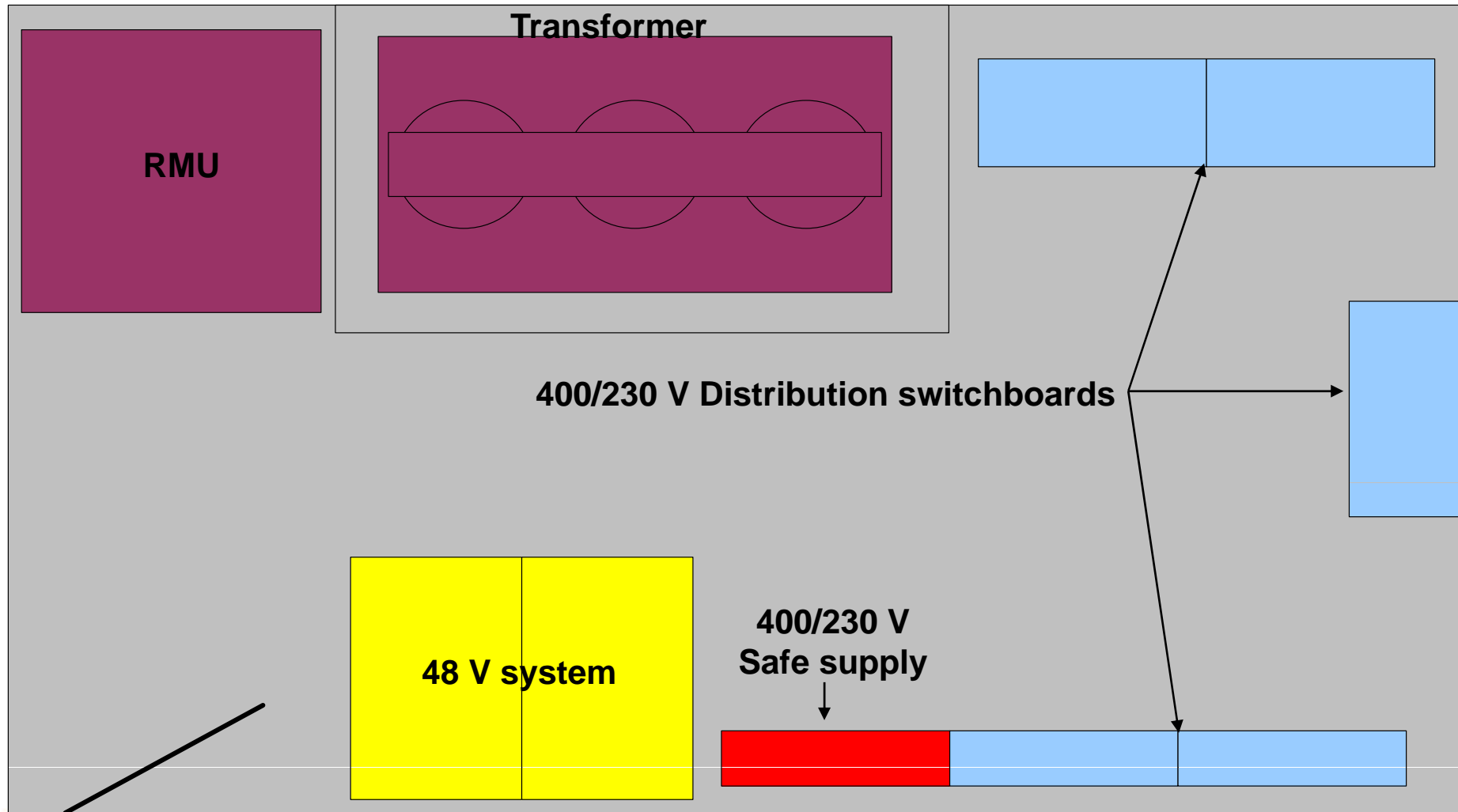



Beam Delivery System

- BDS Load Breakdown
 - **A number of aspects are becoming clearer, but the power distribution for the BDS is still very much a placeholder.**
 - **The reasonably well-defined parts are the H.V. power links and the conventional services.**
 - **The machine related parts are still not clear.**
 - Magnet loads ?
 - Cooling and ventilation?
 - Cryogenics ?
- The integration of this area, most likely with a considerable amount of equipment positioned in the service tunnel, is quite important.



Detectors

- **Detector (s)**
 - Power demands unknown. Exists in the costing as place holder. Scaled on CERN experiments.



Safe power systems

- The safe power systems will be based on diesel generator sets (Short break) and static UPS sets (No break).
- The dimensions of the project will probably require high voltage generation (3.6 kV)
- Long autonomy D.C. systems should be used for critical systems like emergency lighting and network related safety.



Safe Power Systems

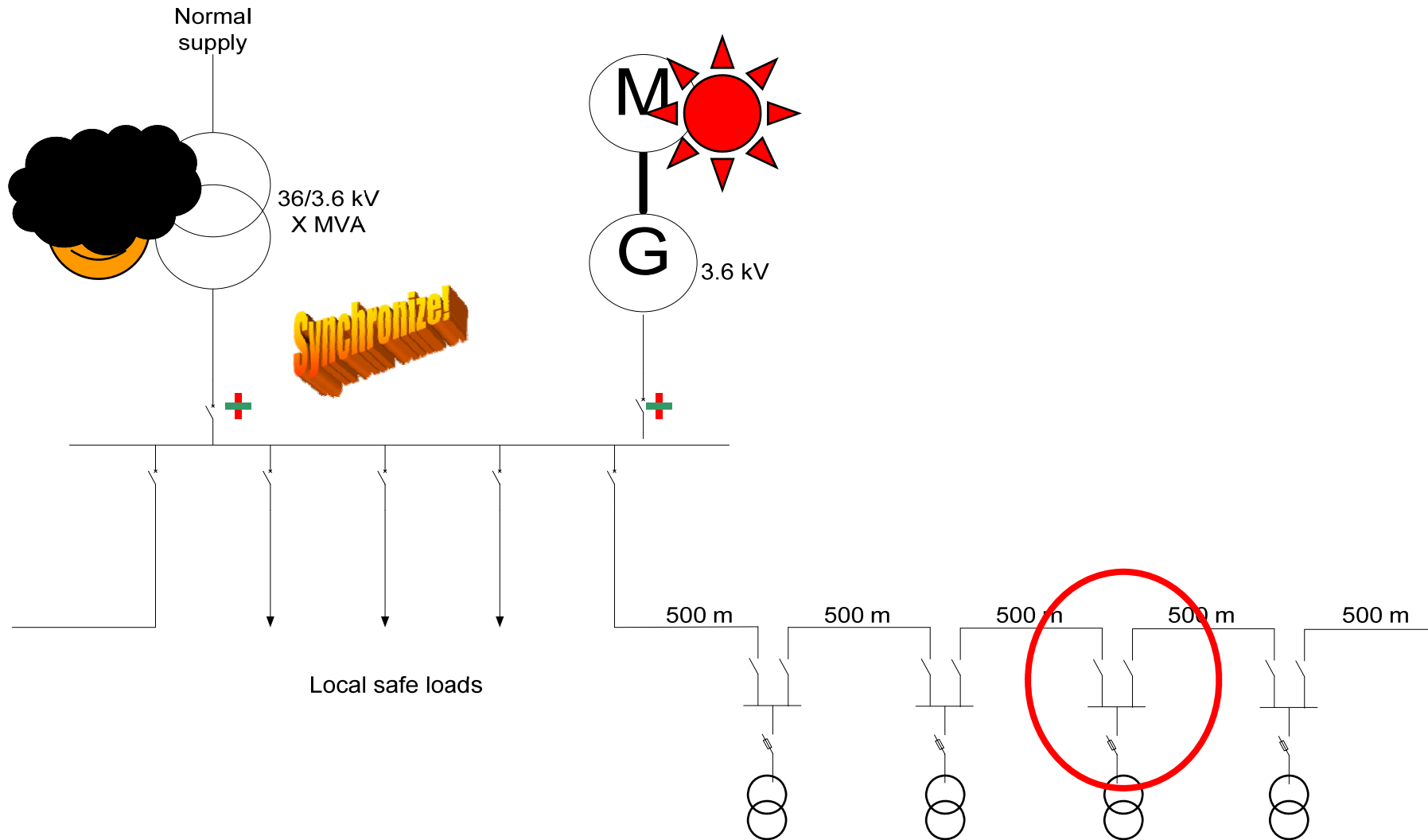



The SCADA system

- **Supervisory Control And Data Acquisition** systems should be purchased from companies with proven expertise in the field!
- In order to obtain success with a SCADA system you should use
 - **Existing, proven standard hardware**
 - **Standard communication protocols**
 - Can be vendor's protocol, if he is big enough in the trade: Siemens, ABB, Westinghouse
 - **Equipment that allows for a certain number of hardwired signals to the local control centers**



The SCADA system

- Accelerator control specialists believe this to be a mundane activity, that they can handle between breakfast and lunch.
- Experience has proven them wrong.
- But that does not keep them from trying.
- A SCADA system is the main source of information about the state of the grid, the statistics, the consumption (\$!) the maintenance etc. It should work as reliable as the network. And that requires professionals.



Outstanding items

- Better specifications of all area systems as *electrical consumers*.
- In that sense development of lay-outs, even simple ones. F. ex in the style of the main linac RF unit.
- Specifications of the BDS and the experiment as electrical consumers.



Outstanding items

- Detailed development of a proposal for the safe supply.
- Detailed development of a proposal for the 48 V DC supply.
- Development of the supply system for the BDS and the Experiments



Conclusion

- The power requirements of the project are stabilizing
- Certain area managers should sit down with the future electrical engineer(s) and work out their power and installation requirements in detail
- This presentation contains a selection of principles for the construction of the ILC power distribution. It is based on **European** equipment, experience, standards and requirements.
- Good luck with the work leading to the EDR!