



GDE FRANCE

Why High brilliance gun is good for the ERL scheme?
And SC GUN?

Alessandro Variola
For the L.A.L. Orsay group



ILC polarised positron source

Basic of the scheme :

- A high density and high repetition frequency electron beam (@1.3 GeV) is stored in a storage ring.
- Electron Bunches impinge on high power laser pulses stored in optical amplification cavities (Fabry-Perot resonators) with high repetition frequency.
- High energy circular polarised gammas (up to ~30 MeV) are produced by Compton effect.
- Gammas are converted in linear polarised electron-positron pairs in a tungsten target.
- Positron are captured, selected and post accelerated up to the energy of injection of the damping ring (5 GeV).
- To compensate the low positron rate per collision (Thomson cross section) the high repetition frequency allows to stack multiple positron bunches in the same damping ring bucket. After 100 stacking the nominal ILC bunch intensity is attained in less than 100 msec.
- It remains other 100 msec for beam cooling.

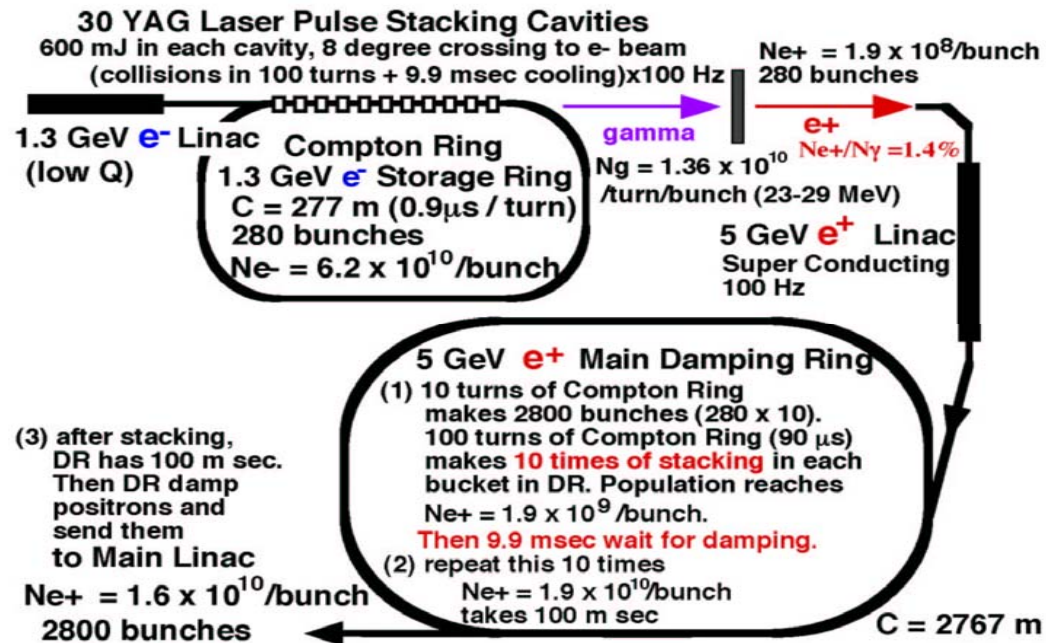



- Independently from the time structure and chosen Compton machine

We need $2 \cdot 10^{10} \cdot 3000 \cdot 5 = 3 \cdot 10^{14}$ positrons per second @5Hz.

Since in our scheme we inject in 100 msec at 5 Hz we need $6 \cdot 10^{13}$ positrons every 100 msec

Let's assume that the capture efficiency is given (1.5 %)

We have to provide $6 \cdot 10^{13} \cdot 100 / 1.5 = 4 \cdot 10^{15} \gamma$ every 100 msec

In the linear regime the flux is dependent by the Compton Cross section is linear with the number of electrons and photons densities (N/V) in the overlapping region.

It is so evident that we try to increase the number and reduce the collision sections => High intensity low emittances.

Overlap => Short bunches or/and Crab path

So, as far as the electron beam is concerned the gamma flux is proportional to the current in the beam (constraint) by the product:

$f_{rep} \cdot \text{charge/bunch} = \text{current (constant)}$



- Let's go back to the Compton scheme:
- We can divide the scheme in different phases:
 - a) Production (Compton ring frequency, FP cavity)
 - b) Capture (AMD magnetic field, target) + polarisation selection
 - c) Stacking in the damping ring (3D emittance, rep frequency)

Point a) requires high cross section (charge per bunch)

Point b) requires low frep (or train of pulses) for pulsed magnet, and good e^- bunch emittance for polarisation selection

Point c) requires very good 3D emittance and low frep

So talking about Compton collision we need (at the same current) to provide a machine that increase the charge per bunch and decrease the frep.



Posipol scheme: we have proposed a unique "lepton source" ERL based

Polarised positron source - Compton cavities + ERL

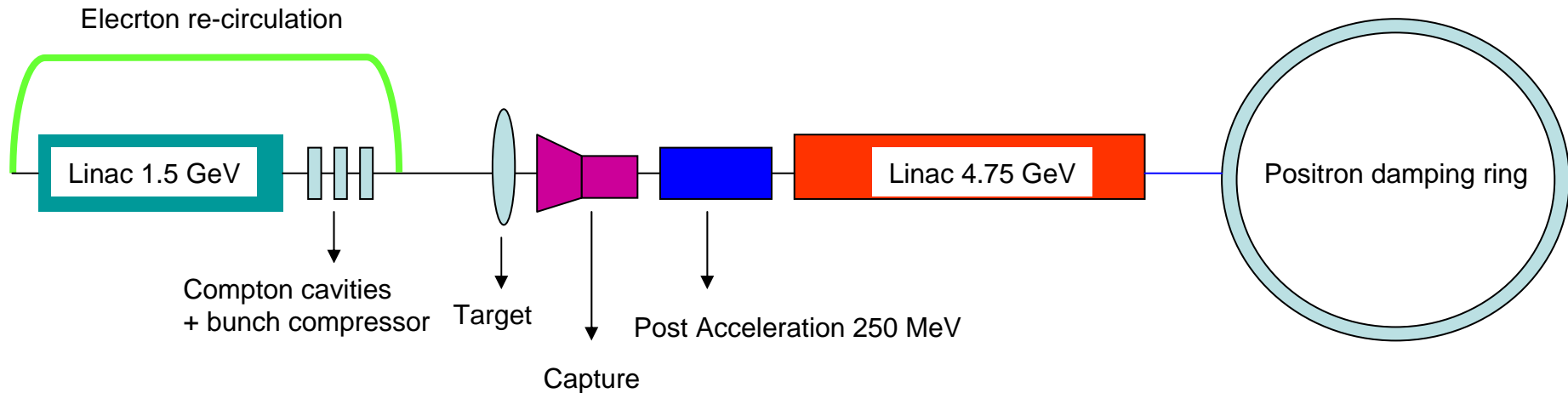

Advantages : short bunch (higher overlap and cross section), short bunch in the capture, lower problems in stability due to the Compton interaction.

Disadvantages : CW, lower emittance



Two sources. One source every damping ring
If damping rings in the same locationnew scenarios:

Electron polarised (unpolarised) source
Polarised positron source - Compton cavities + ERL.
(Splitting = Multi-injection in both rings)

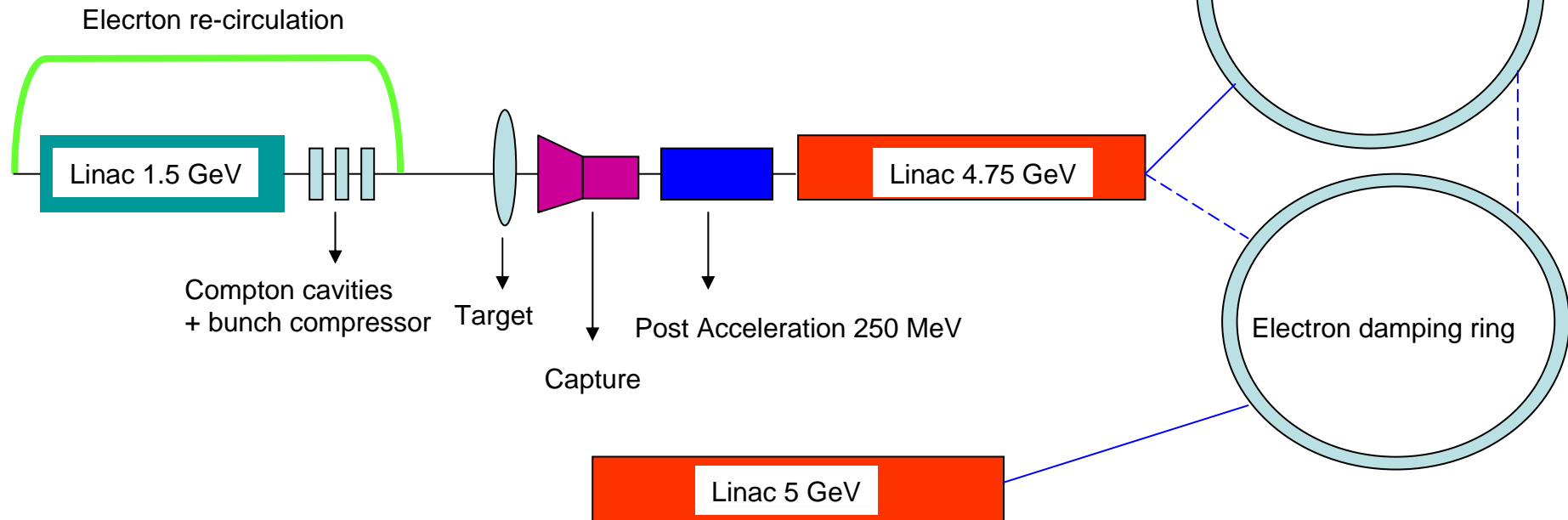

The first 1.5 GeV linac can be substituted with a 6 GeV one to have both sources



Electron polarised (unpolarised) source
Conventional & Polarised source - Compton cavities + ERL.
Damping rings in the same location (splitting)

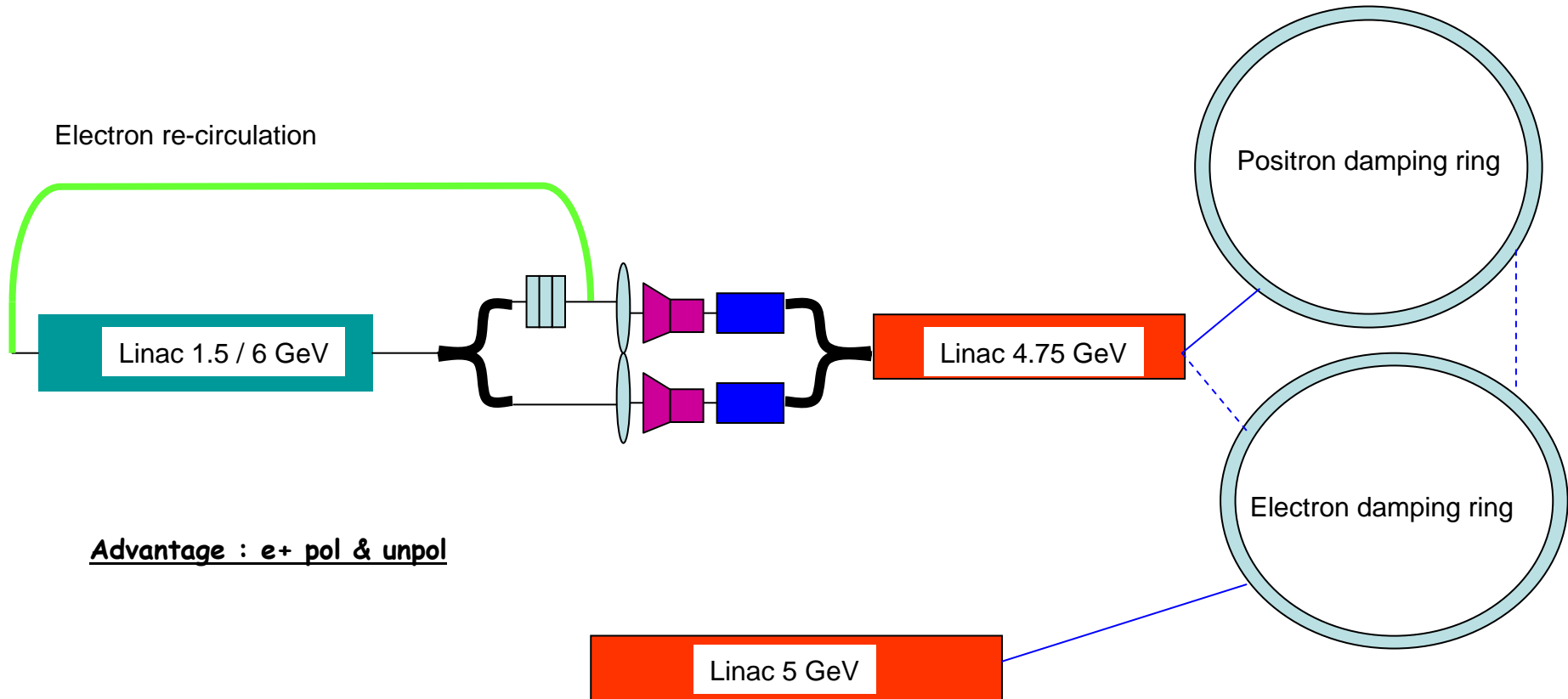

Advantage : e+ pol & unpol

But positron injection takes not more than 100 msec. The remaining 100 msec are enough for electron cooling, so we can split electron and positron injection in time and unify the electron and positron linacs :



IF DAMPING RINGS @ THE SAME LOCATION

Electron polarised (unpolarised) source
Conventional & Polarised source - Compton cavities + ERL.
Damping rings in the same location
(splitting...why not also for the conventional solution)

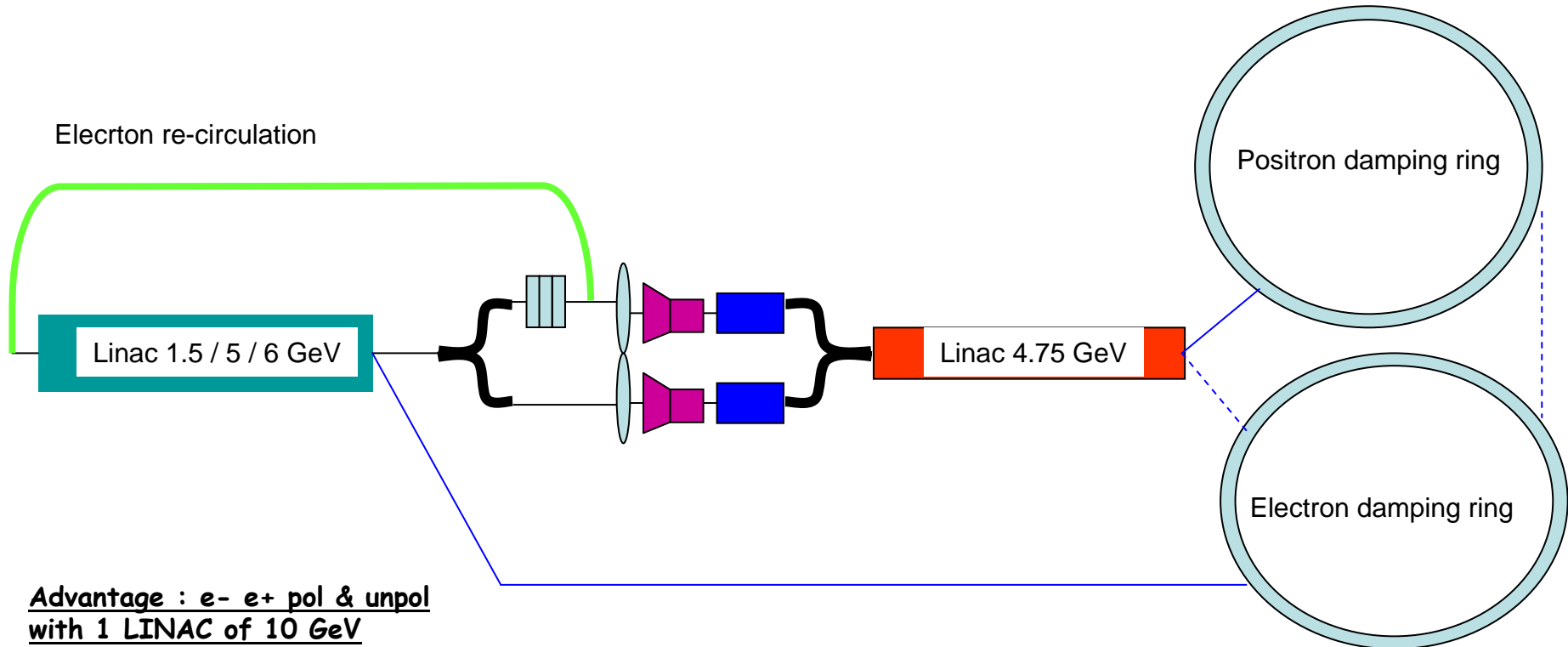

1 Complex !!!! Moreover, if we can re-circulate and split the first Linac we can avoid the second one



IF DAMPING RINGS @ THE SAME LOCATION

Electron polarised (unpolarised) source

Conventional & Polarised source - Compton cavities + ERL.

Damping rings in the same location (splitting)

=> e^+, e^- pol / non pol

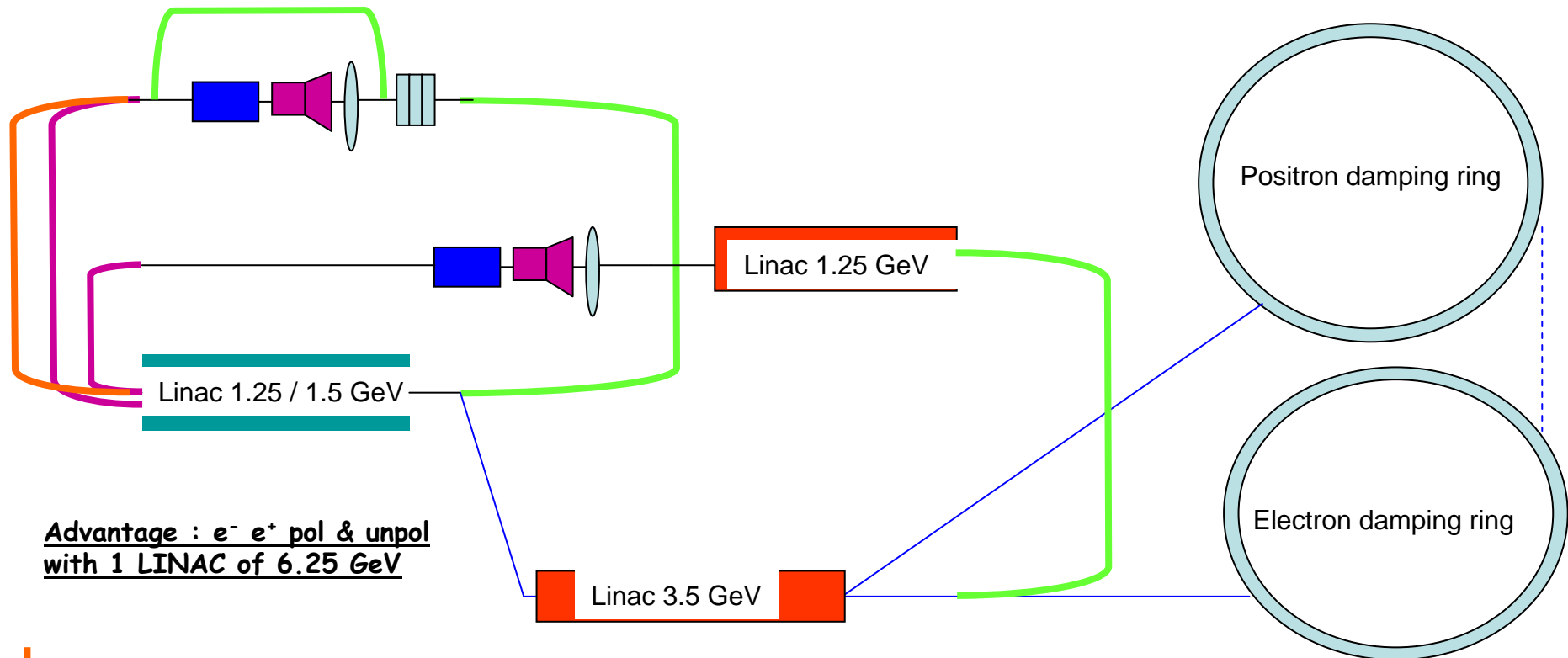

Advantage : e^- e^+ pol & unpol
with 1 LINAC of 6.25 GeV

Electron re-circulation

Positron re-circulation

Disrupted electrons and polarised positrons are re-circulated in the same train
(deceleration for electrons and acceleration for positrons)



- Let' s have some estimate: 0.6 J in cavity (are we dreaming? I think not) and 1.5 nC per bunch $\sim 10^9$ gammas.
- So we need $4 \cdot 10^6$ bunches in 100msec = 40 MHz. But $1.5 \text{ nC} * 40 \text{ MHz} = 60\text{mA}....$

(remember we can relax the parameters using more cavities, up to ten, so 6 mAmps....)

- The existing ERL (Jlab) = 10 mA, 0.13nC,75MHz. But different projects goals attain the 100 mAmps.....
- So what we are looking for as average current is feasible. The main problem is that high current ERL uses schemes with high freq (up to 1.3 GHz) and low charge per bunch ($\sim 0.1 \text{ nC}$).

- To go in this direction one of the main problem is the source
For high average current the Thermal design of the NC sources is extremely demanding.
- We need an injector that, with the same average current, provides high charged bunches with very good emittances.
- The advantage is that we do not need very short bunch in the source since we can compress after. (And also OPO crab after if we want).



- So for our scheme it is crucial to support all the R&D that can provide a source for an ERL with :
- High current, high bunch charge, low emittance, (short bunches)
- The parameters that can “absorb” this requirements are the f_{rep} and the bunch length.



RF GUN status/Projects

JLab	AES JLAB	Cornell	Dares. ERLP	JAERI Th.Ionic	BINP Th.Ionic	Boeing	LANL AES	LUX	AES BNL	4GLS	
DC	DC	DC	DC	DC	Dc	NCRF	NCRF	NCRF	SRF	SRF	
1.5	0.75	1.3	1.3	0.5	0.18	0.433	0.7	1.3	0.7	1.3	RF (GHz)
0.075	0.75	1.3	0.08	0.01 (0.083)	0.011 (0.09)	0.027	0.033 (0.35)	1.3	0.35	1.3	frep
0.133	0.133	0.077	0.08	0.5	1.7	4.75	3.0	1.0	1.4	0.08	Q (nC)
10	100	100	6.5	5 (40)	20 (150)	32	100 (1050)	1300	500	100	I (mA)
<7	1.2	<1	1.5	30	32	~7	6		2.1	0.5	ϵ (μ m)
3.2	6.3	2	4		50				15		ERL bl (ps)
44	44	30	20			53	16			10	Laser bl (ps)
527	527	527	527			527	527		527	527	Laser wl (nm)



	Operational ERL guns			ERL guns under commission	
Facility	JLab ERL FEL	JAERI ERL	BINP ERL FEL	Daresbury ERLP	Cornell ERL
Gun type	DC	DC	DC	DC	DC
Voltage (kV)	350	230	300	350	300 (750)*
Cathode	photocathode (GaAs)	thermionic	thermionic	photocathode (GaAs)	GaAs or GaAsP
Average current (mA)	10	5	20 ~ 40	6.5	100*
Beam energy after booster (MeV)	7~10	2.5	2	8.35*	5 ~ 15*
Booster type	SC rf	SC rf	NC rf	SC rf	SC rf
Booster frequency (MHz)	1497	499.8	180	1300	1300
Norm. rms emit (μm)	<10	30	32	1.5*	<1*
Note				first beam in 08/2006	first beam 09/2006

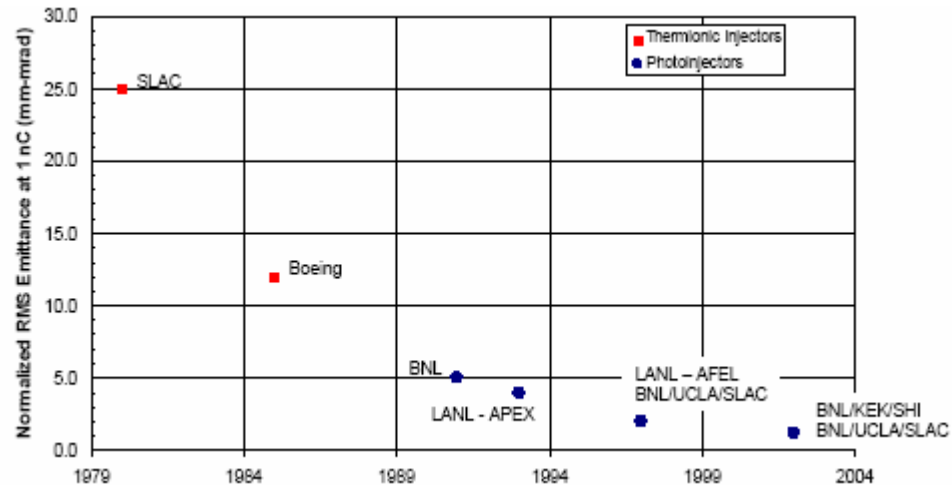

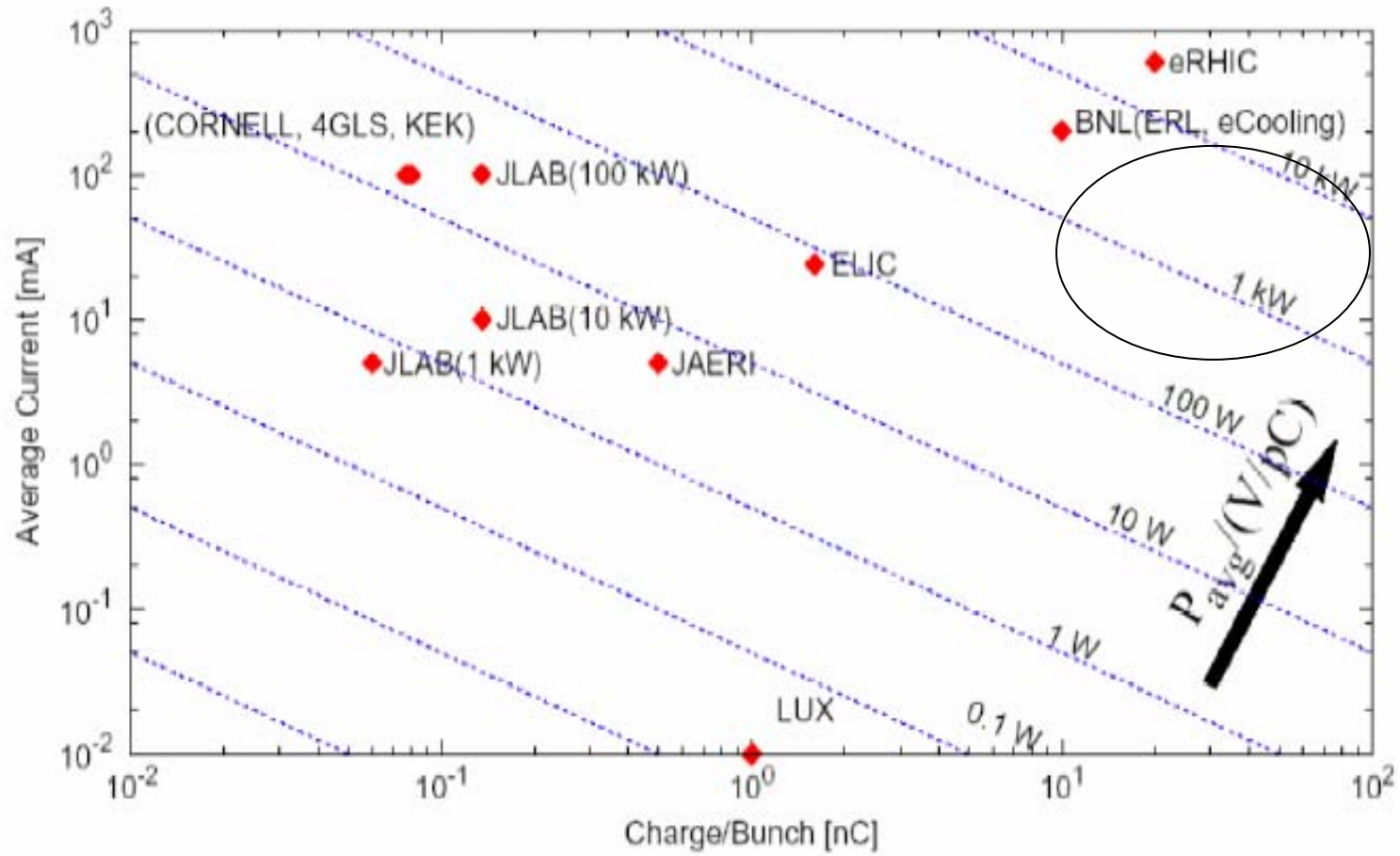



TJNAF High-Average-Current DC Photoinjector

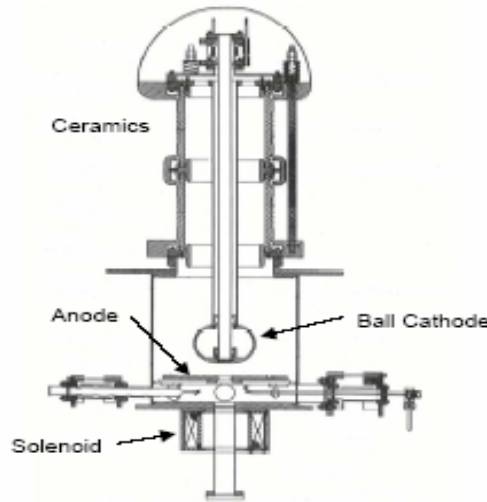

Voltage	320 kV
Duty factor	CW
Charge per bunch	135 pC
Repetition rate	37.425 MHz
Average current	5 mA
Cathode	GaAs
1/e cathode lifetime	58 Hours
RMS emittance	25 mm-mrad
RMS temporal length (after bunching)	0.4 ps

- Driver for FEL with output power in excess of 2.1 kW.
- Cathode lifetime limited by ion back bombardment.
- Voltage limited by field emission (design voltage 500 kV).

T. Siggins, et al., *Nuclear Instruments and Methods A*, 475, p. 549, 2001.

TJNAF/AES High-Average-Current DC Photoinjector: Future Possibilities

Gun voltage	500 kV	
Average current	100 mA	
Beam energy	10 MeV	
Bunch charge	1 nC	2 nC
Transverse emittance	7.5 mm-mrad	10 mm-mrad
Longitudinal emittance	30 deg-keV	50 deg-keV
RMS bunch length	4 ps	5 ps

Example Photoinjector NC



SCRF GUN

(Ferrario Moeller Rosenzweig Sekutowicz, Travish)

Parameters proposed for the R&D (Simulations PARMELA)

Charge/bunch= 1nC

Frep=1MHz

RF=1.3 GHz

En Bunch=6 MeV

Coupler at 6kW

Bunch length= 20 ps

Rms emittance= $1\mu\text{m}$ @ 1nC - $0.7\mu\text{m}$ @ 0.35 nC

Problems to be solved : Laser power (best QE at $\sim 200\text{nm}$), Cathode material (lead, back illuminated neobium...), Bfield for focalisation and emittance compensation, Emittances and field asymmetries (couplers), Thermal emittances in the cathode.



SC Advantages and answers to have

- Low power consumption
- Very low emittance = > good for photon collection on the target and for polarisation diaphragming (convolution between the energy spectrum and the electron beam angular divergence)
- Short bunches (no need of strong compression)

- What are the achievable limit in current and charge per bunch?
- Can we think to have a very long bunch/high charge and to apply both bunch compression and crab at the IP (final goal 5 mm bunch) ? What is the limit of this scheme?



- Summary
- 1) For the ERL scheme is important to have an important ch/bunch, low frep, short bunch length and very good emittance.
- 2) We can "charge" other parameters as the energy spread and the frep
- 3) We do not know what is the best technology but we follow with big interest all the R&D developments for such beams.
- 4) The SC gun can be surely a solution in the future.