



Cryomodule Report

N. Ohuchi KEK

1. Cryomodule & Cryogenics KOM
2. GDE-meeting discussion
 - I. Interface on the cryomodule
 - II. Specification table
 - III. Work packages
3. Summary



Cryomodule and cryogenics KOM-1

Date	On the KOM of the cryomodule and cryogenics, European group will join via Webex.
2007/September/12 9:00~9:10	Introduction – toward the EDR : B. BARISH
9:10~9:20	Organization of members : A. Yamamoto
9:20~9:50	Definition of work area between groups : N. Ohuchi
9:50~10:20	Basic strategy of designing cryomodule : H. Hayano
10:20~10:35	Break
10:35~11:20	Status report and work package plan of US : H. Carter
11:20~12:05	Status report and work package plan of Asia : N. Ohuchi
12:05~13:30	Lunch
13:30~14:15	Type 4 cryomodule design work : D. Mitchell
14:15~15:15	Construction experience of LHC dipole cryostats : V. Parma
15:15~15:30	Break
15:30~17:00	Drawing up the work and R&D list for EDR : H. Carter/N. Ohuchi
2007/September/13 9:00~9:45	Cost estimation of cryomodule for EDR : R. Stanek
9:45~10:30	Industrialization of cryomodule for EDR : US R. Kephart, Japan
10:30~10:45	Break
10:45~11:30	Review of the cryogenic system RDR work : T. Peterson
11:30~12:15	Work package plan of cryogenic system for EDR : T. Peterson
12:15~13:30	Lunch
13:30~14:30	Cryogenic experience from CERN LHC : L. J. Taviani
14:30~14:45	break
14:45~17:00	Work sharing between three regions : All
2007/September/14 8:00~8:45	Agreement for EDR works : S. Mishra
8:45~9:30	Time line and mile stone of work package for EDR : R. Stanek
9:30~11:15	Break and tour
11:15~12:00	Close out : A. Yamamoto

Cryomodule and Cryogenics KOM

Sep. 12-14 at KEK

Presentation:

Management issue:

Barish, Yamamoto, Mishra

Technical issue:

7 presentations (FNAL),

2 presentations (CERN),

6 presentations (KEK)



Cryomodule and cryogenics KOM-2

- Goal of the KOM
 - **Preparing a plan for the development of the design and mass-production or industrialization of the main linac cryomodule and cryogenic system.**
 - The most important discussion
 - the degree to which the cryomodule design would be completely unified, to the finest detail, or developed using a ‘plug-compatibility’ strategy
 - Have to determine how far to press for a unified design and how to set component and interface definitions so that design and development work on interchangeable components could proceed.



Cryomodule and cryogenics KOM-3

Possible C3-level plug-in compatible components

C3-level:

Cryostat vessel, GRP supports, Pipes, Thermal Shields, Invar fixture, Cavity support, Quad support, Cryostat Pumping system, Instruments(vacuum, temperature, etc), Installation fixture and method, Transportation fixture and method, ...

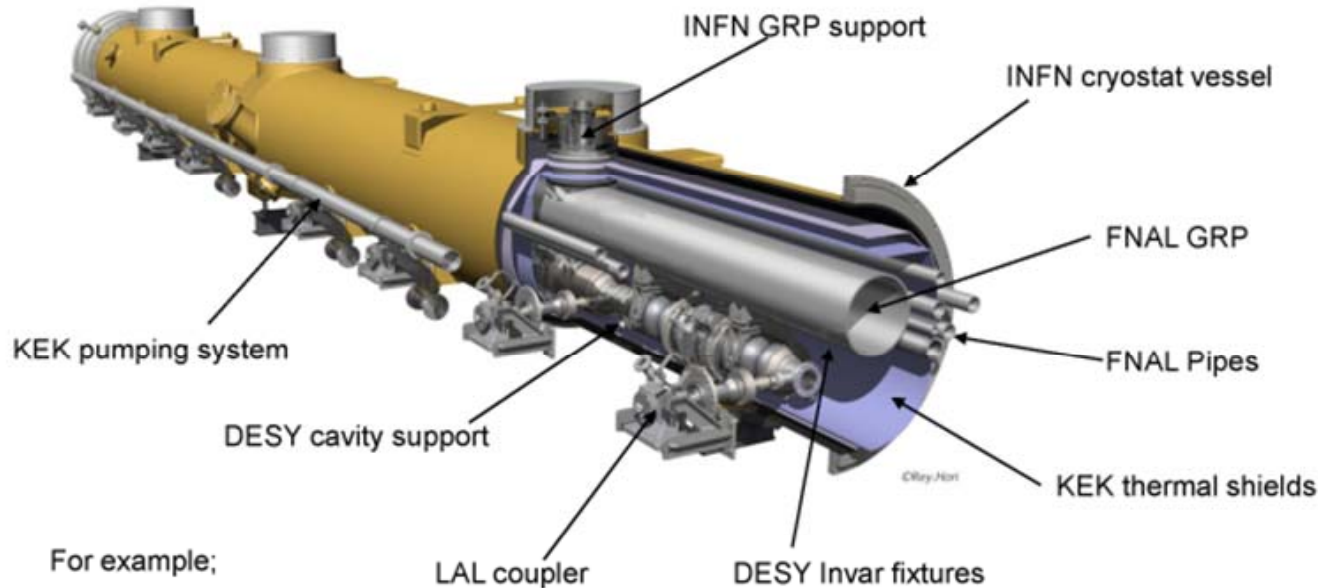

From Hayano's presentation

Specification and interface definition are important.



Cryomodule and cryogenics KOM-4

Another Discussions of KOM

- The strategy and completeness of the design, industrialization and procurement plans which were assembled for the RDR.
 - **Quality Assurance is the process by which an organization takes responsibility for a product and must include a testing, recording and documentation plan. The EDR should include a model of QA.**
- EDR plans for further development of the value estimate.
 - **Cost containment and reduction of cryomodule and cryogenic systems are high priority ED phase activities. Value engineering of the CM is prioritized activity.**
- EDR plans for industrialization
 - **CM procurement model**
 - **Intellectual property rights – design material (CAD): limited non-disclosure agreement**
- Work Packages for the EDR goal
 - **Parallel Development of CM in three regions and Design Convergence on a single function – Working Agreement**
 - **Work Package definition: A draft schedule leading to the construction of the ILC**
 - **Performance specification for the strategy of ‘Plug-compatible’**



Cryomodule and cryogenics KOM-5

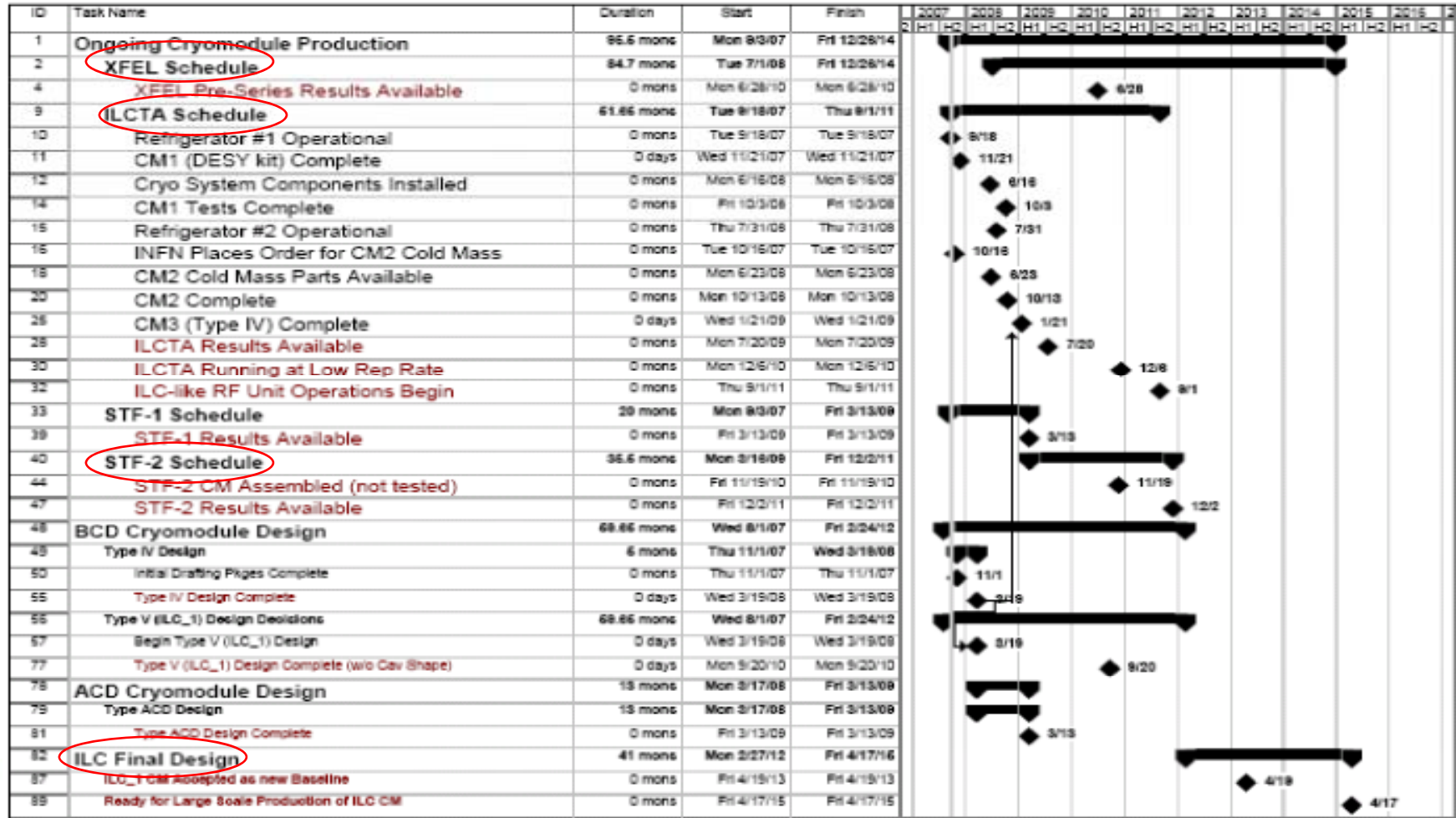

From Stanek's presentation



Interface on Cryomodule -1

- Cavity package

- Helium jacket

- Connection between helium supply pipe and helium jacket
 - Connection between pre-cooling pipe and helium jacket
 - Connection flanges between jacket and bellows
 - Connection flanges between cavity package and beam pipe between cryomodules
 - Sliding support
 - Connection to invar rod

- Input coupler

- Connection flanges between warm-coupler and vacuum vessel
 - Connection to thermal interceptor

- Tuner (which has the drive motor outside the vacuum vessel)

- Connection flanges between drive motor and vacuum vessel
 - Connection to thermal interceptor
 - Cabling



Interface on Cryomodule -2

- Quadrupole package
 - Connection between the cooling pipe and quadrupole jacket
 - Support fixture
 - Current leads
 - Thermal interceptor
- Cryogenic components
 - **End box and service end box**
 - Connection between the cooling pipes in the cryomodule and the end box
 - Connection between the cooling pipes in the cryomodule and the service end box

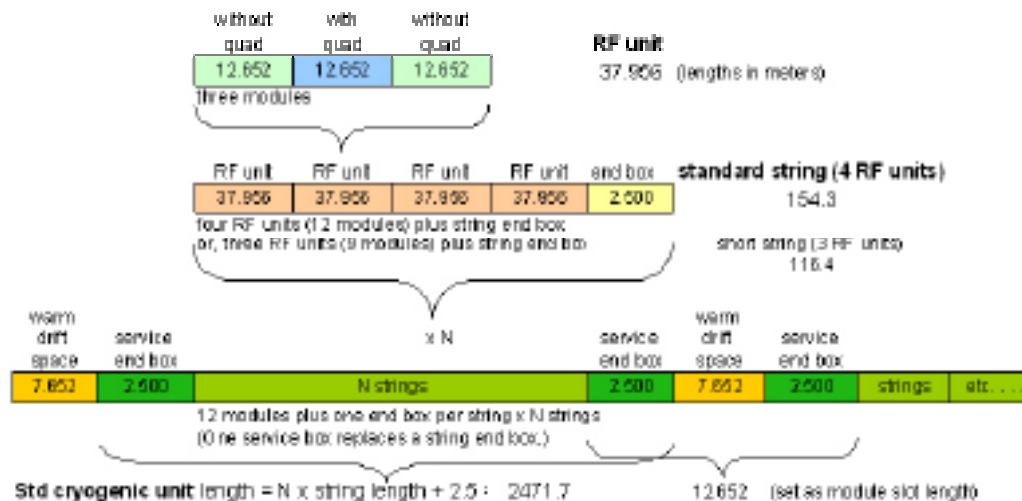



Interface on Cryomodule -3

- Vacuum components
 - **Beam line vacuum system**
 - Vacuum ports on the beam line and vacuum vessels, and pumping pipes in the cryomodule
 - **Insulating vacuum break**
 - Connection between pipes and vacuum breaks, bypass valve
 - **Coupler vacuum system**
 - Coupler vacuum port and pumping pipes

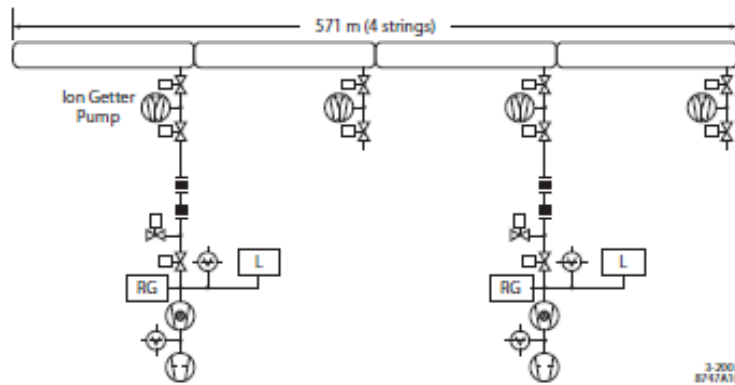

FIGURE 3.2-1. Beamline vacuum system – 2 turbo-molecular pumps (TMP) with high sensitivity leak detector (LD) and residual gas analyzer (RGA), safety, clean venting system, slow start pumping etc.

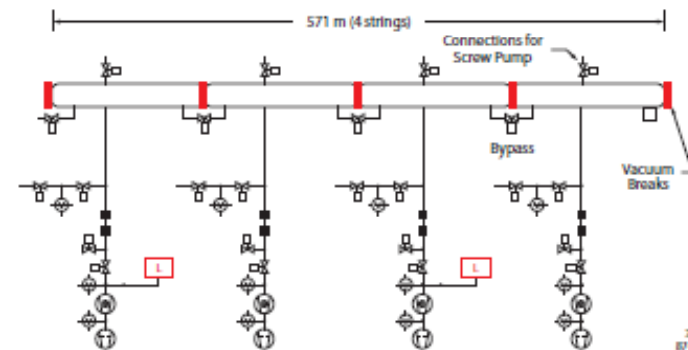

FIGURE 3.2-3. Insulating vacuum system – 4 TMP pumping units: 2 with LD (leak detector) + 2 large screw pump for fore pumping.



Specification table of cryomodule -1

		8 C + 1 Q	9 C + NoQ.
Number		627	1188
Heat Load	at 2K	11.7 W	11.2 W
(Static + Dynamic)	at 5K	14.2 W	16.5 W
	at 40K	149.4 W	161.7 W
Alignment Tolerance	Cavity offset w.r.t. cryomodule	0.3 mm	0.3 mm
[RMS]	Quadrupole offset w.r.t cryomodule	0.3 mm	
	Quadrupole rotation w.r.t. design	0.3 mrad	
	Cavity pitch w.r.t. cryomodule	0.2 mrad	0.2 mrad
	Cavity yaw w.r.t. cryomodule	1 mrad	1 mrad
	Cryomodule offset w.r.t. design	0.2 mm	0.2 mm
	Cryomodule pitch w.r.t. design	0.02 mrad	0.02 mrad
	Cryomodule yaw w.r.t. design	0.1 mrad	0.1 mrad



Specification table of cryomodule -2

Vacuum vessel	Length (including the vacuum bellow)	12652	12652
	tolerance of length	±3	± 3
	Outer diameter	965.2	965.2
	Inner diameter	955.7	955.7
	Position of vacuum center axis with respect to floor		
	Input coupler port	8	9
	specification of connection flange with input coupler		
	position of the port		
	distance from the flange outer surface to the beam line		
	alignment tolerance of the flange		
	offset w.r.t. design (X, Y, Z)		
	tilt w.r.t. design		
	Tuner driver port	8	9
	position of the port		
	specification of connection flange with tuner driver		
	Quadrupole package port	1	0
	position of the port		
	current lead terminals	6	0
	Vacuum port		
	specification of flange		
	Connection flange to the next cryomodule		
	specification of the flange		
	Residual magnetic field		



Specification table of cryomodule -3

Helium jacket	Length (between connection flanges)	1247.4	1247.4
	Inner diameter	230	230
	Thickness		
	Position of beam pipe and cavity center axis w.r.t. the vacuum vessel center		
	Support pad		
	position & tolerance		
	machining tolerance w.r.t design	0.05	0.05
	LHe supply pipe location on the jacket (r, θ, z)		
	alignment tolerance w.r.t. design		
	LHe precooling pipe location on the jacket (x,y, z)		
	alignment tolerance w.r.t. design		
	Maximum design pressure		



Specification table of cryomodule -4

Cooling pipes			
2.2 K subcooled supply	Inner diameter , mm	60	60
pipe	Maximum design pressure , bar	22	22
Major return header	Inner diameter , mm	300	300
(GRP)	Maximum design pressure , bar	2 to 4	2 to 4
5K shield and intercept	Inner diameter , mm	56.1	56.1
supply	Maximum design pressure , bar	22	22
8K shield and intercept	Inner diameter , mm	70	70
return	Maximum design pressure , bar	22	22
40K-80K shield and	Inner diameter , mm	72	72
intercept supply	Maximum design pressure , bar	22	22
40K-80K shield and	Inner diameter , mm	80	80
intercept return	Maximum design pressure , bar	22	22
2-phase pipe	Inner diameter , mm	72.1	72.1
	Maximum design pressure , bar	2 to 4	2 to 4
Helium vessel to 2-phase	Inner diameter , mm	54.9	54.9
pipe cross-connect	Maximum design pressure , bar	2 to 4	2 to 4



Specification table of cryomodule -5

GRP as the support structure	Machining tolerance of the flanges	0.1	0.1
	to the support post w.r.t. design , mm		
	Machining tolerance of the support	0.1	0.1
	feet for cavities and quad w.r.t. design , mm		
Thermal radiation shields	Number of shields (1 shields or 2 shields)		
	Operation temperature , K		
Support post	Number of posts	3	3
	Maximum load for one post , N		
	Machining tolerance of the end flange surface		
Quadrupole package	Length , mm	< cavity slot length	
	Outer diameter ,		
	Operation temperature , K	2	2
All components in Cryomodule	Max. temperature difference during the cool-down and warm-up , K		



Cryomodule WP -1

1. Cryomodule Documentation and Standards for Manufacture and Testing **A** (2007-2009)

- Cryomodule design specification, Interface with another groups
- Standards for cryomodule manufacture (HP gas regulation, ANSI/ASME/ISO, etc), quality assurance plan

2. Cryomodule Components Development and Design

- Cooling pipe design (with Cryogenic group) **A** (2007-2008)
 - Calculation of pressure drops, definition of the maximum pressure, cooling procedure, new piping on the module transverse cross-section.
- Developing and evaluating the thermal model with and without 5K thermal shield (with Cryogenic group) **A** (2007-2008)
 - Thermal calculation of these two models, evaluation of the production cost and operation cost.
- Design of cavity string (with Cavity group) **A** (2007-2009)
 - Finalization of the design of a consistent helium jacket-tuner design, bimetal junction, alignment method of cavities in the cryomodule.



Cryomodule WP -2

- **Design of assembly of the quadrupole and corrector package with BPM supported from center post (with Magnet group) A (2007-2009)**
 - Assembly and support design of quadrupole package and current leads.
- **Magnetic shielding system A(design) B(verification) (2007-2009)**
 - Design of the inner and outer cavity magnetic shield, demagnetization of the vacuum vessel.
- **Vibration analysis of the quad and cavity support structure and comparison with measurements A 2008 (design) 2010 (verification of design)**
- **Special cryomodule development C (2010)**
 - Conceptual design of separate quad cryostat, quadrupole package doublet
- **Design of inter-connection between components C (2010)**
 - Design of the inter-cavity connection, interconnection between Module-to-Module.
- **Design of Instrumentation and Vacuum C (2007-2010)**



Cryomodule WP -3

3. **Optimization of the Cryomodule Assembly with Designing Components (for cryomodule in three regions) B (2009)**
 - Documentation of procedures and tests of the cryomodule assembly. Design and construction of assembly fixtures
 - Design of the assembly facility
4. **Cryomodule Global Design with 3D and 2D CAD on EDMS A (2008-2010)**
5. **Design of Cryomodule Test C (2010 early)**
 - Defining the test items and planning the schedule of the cryomodule test, requirements for the test stands
 - Design of the cryomodule test facility
6. **Shipping Study of Cryomodule C (2010)**
 - Definition of maximum allowed loads and transport fixtures, and identification of the critical issues and components during transport
 - Collecting data from SNS



Summary

1. Interfaces on the cryomodule were defined with cavity package and cryogenic components. They will be documented as one of the cryomodule WPs.
2. Specification table was proposed. The items were confirmed, and the values will be defined in near future.
3. 17 WPs of cryomodule were proposed. All items were discussed with the cryomodule, cryogenics and cavity groups, and they were confirmed with the technical groups.