

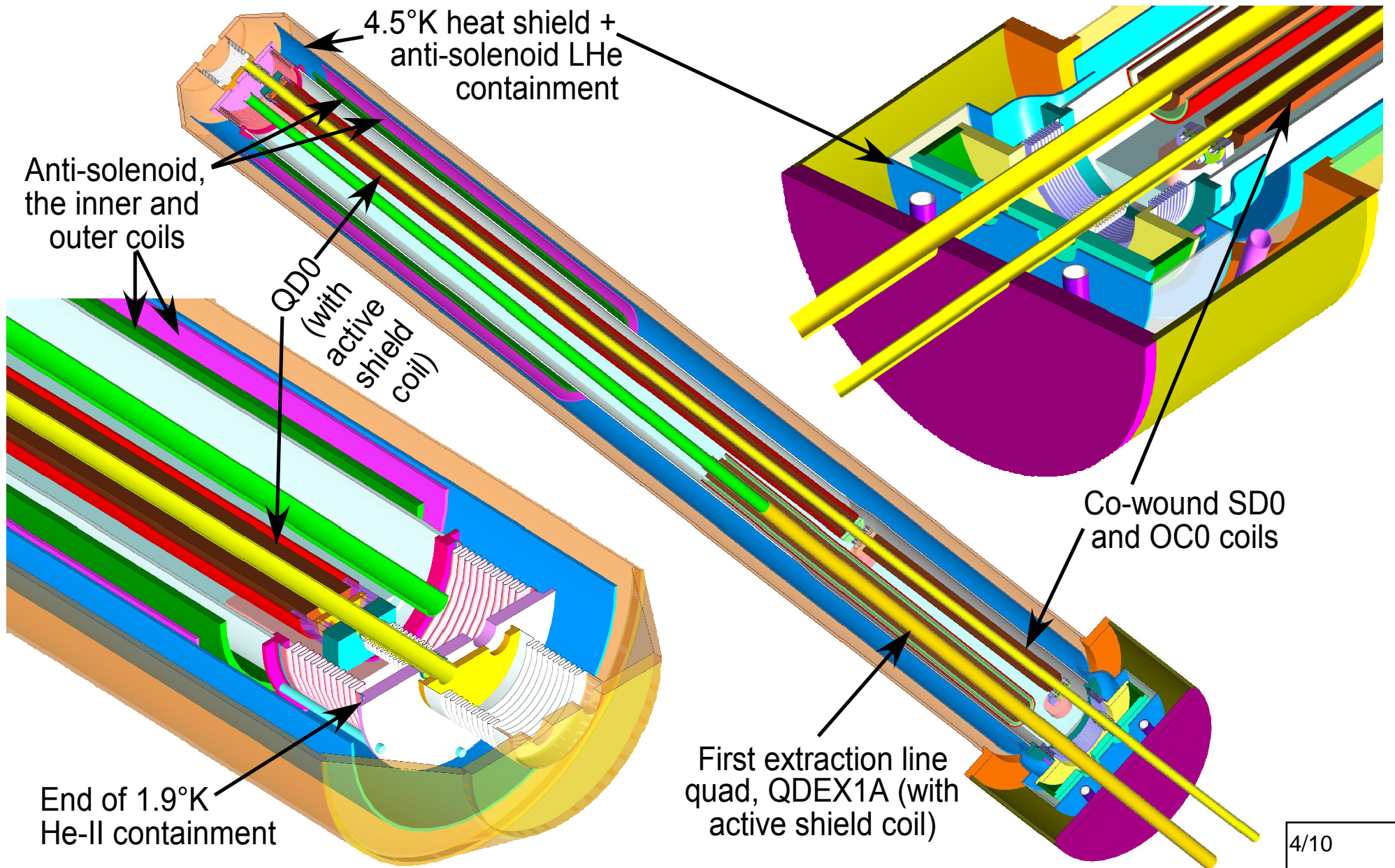

Incorporating a Force Neutral Anti-Solenoid Into the QD0 Cryostat.





QD0 Cryostat Design Details: (Plan View).

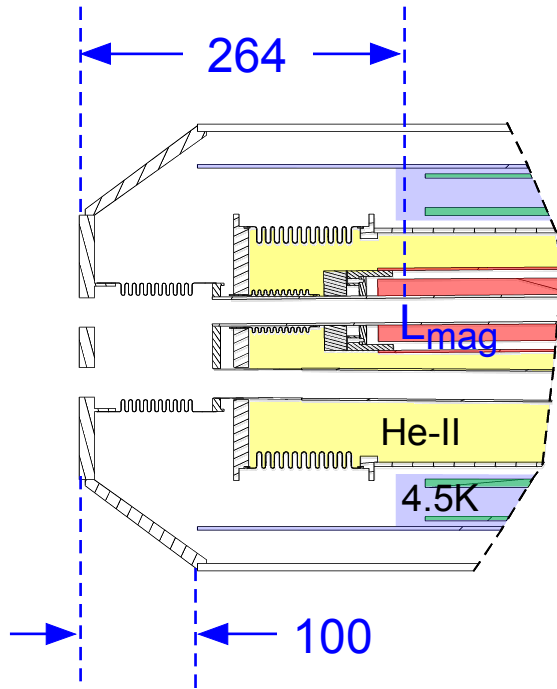

QD0 cryostat with a force neutral anti-solenoid compatible with L^* of up to 4.5 m.

Plan views are drawn at beams' common midplane; dimensions are as indicated in millimeters.

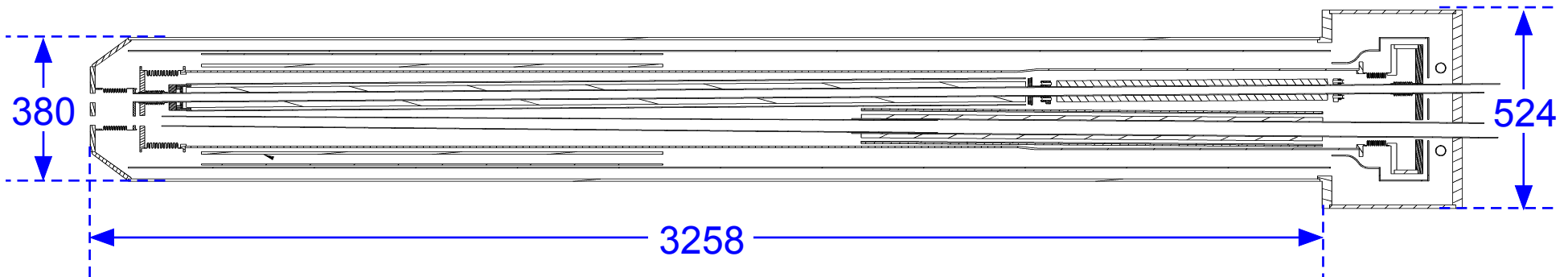
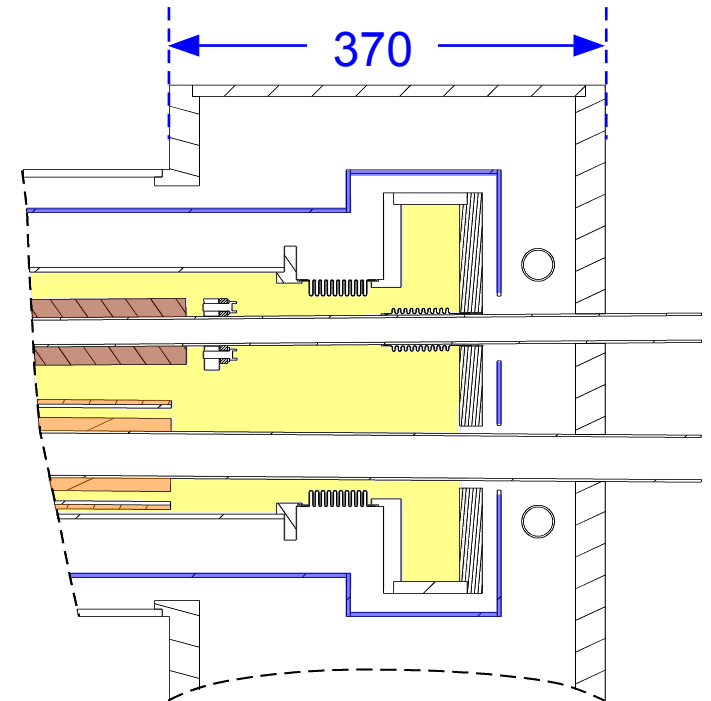



QD0 Cryostat Design Details: (Elevation Views and QD0 Section).

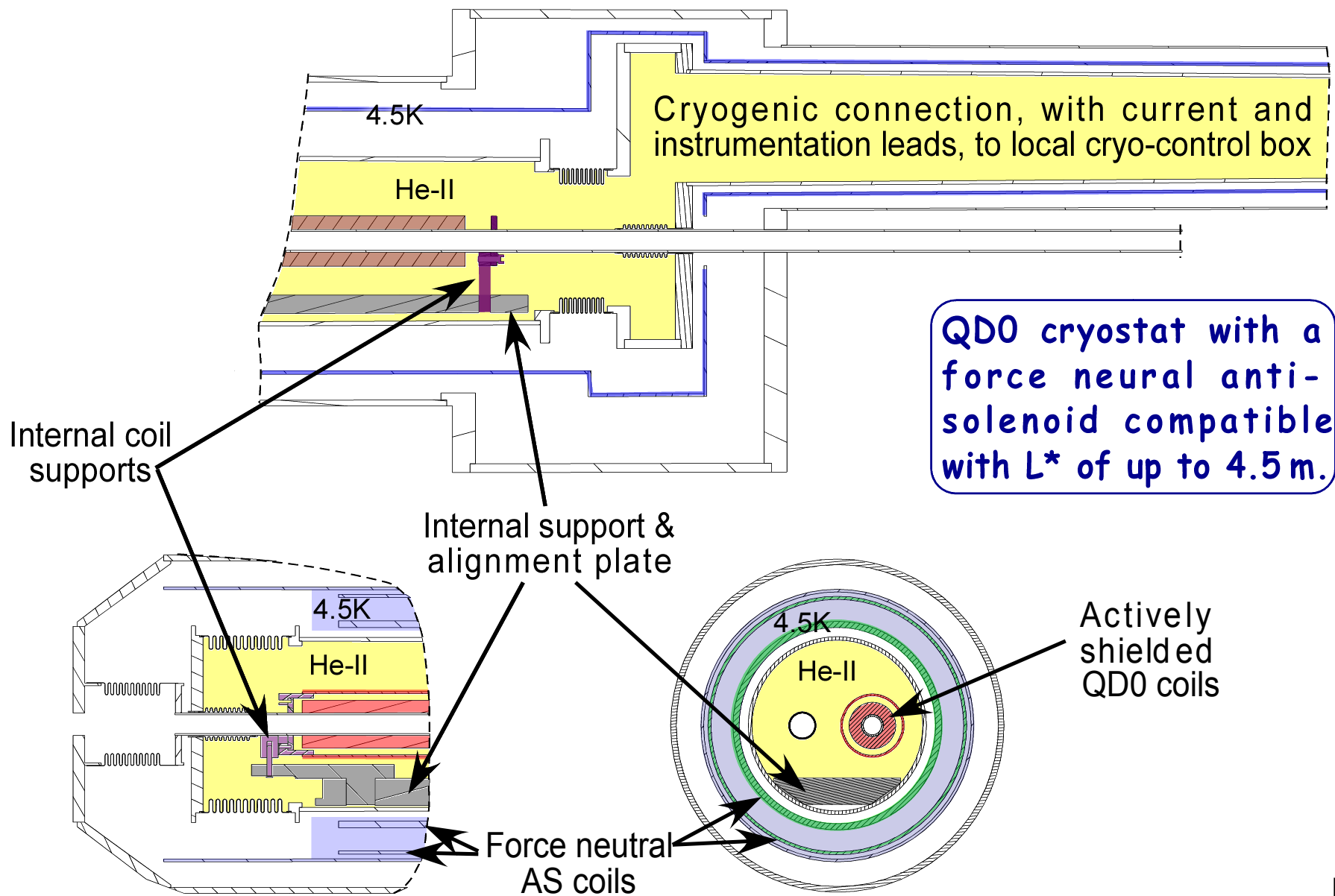

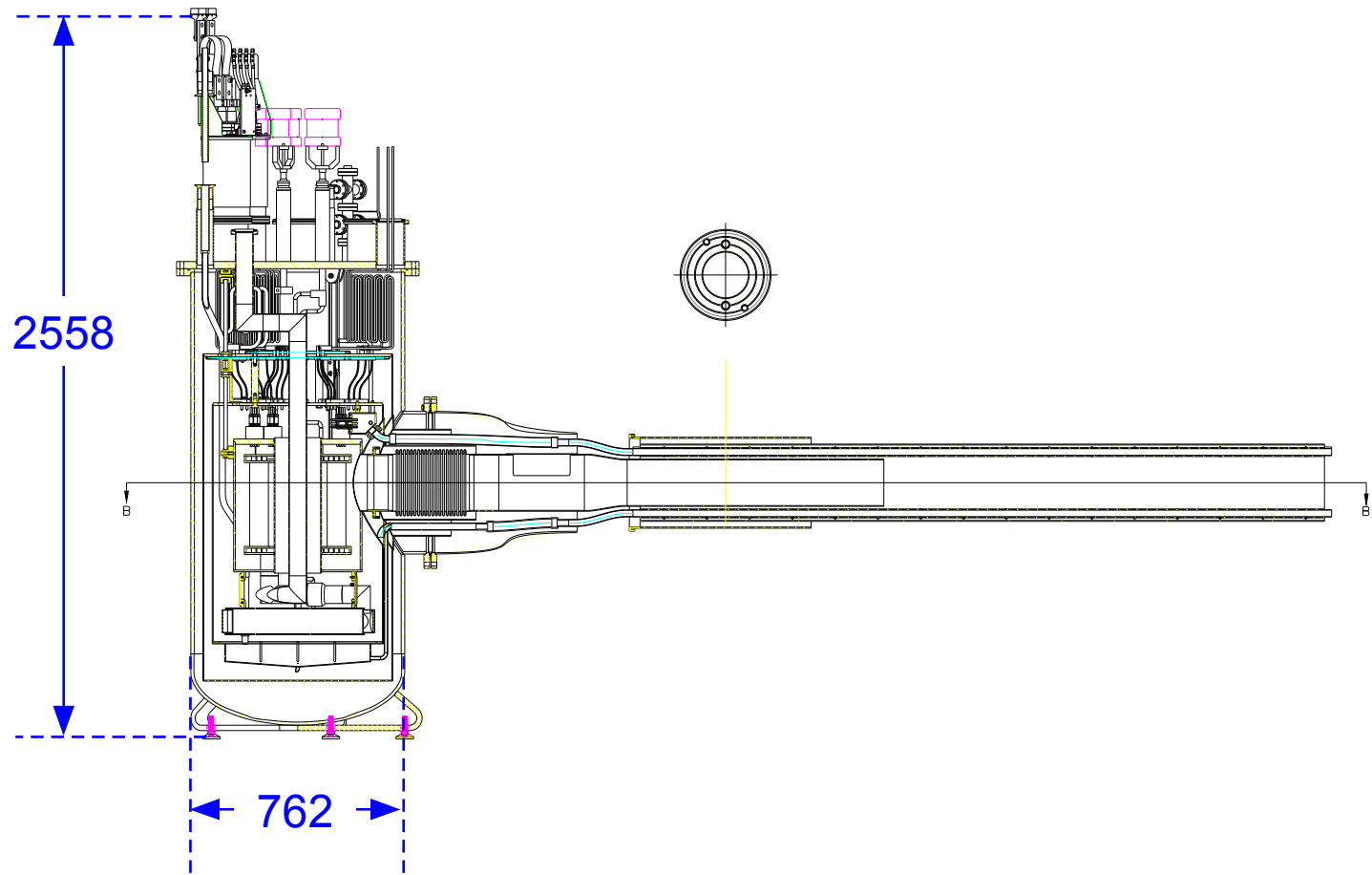
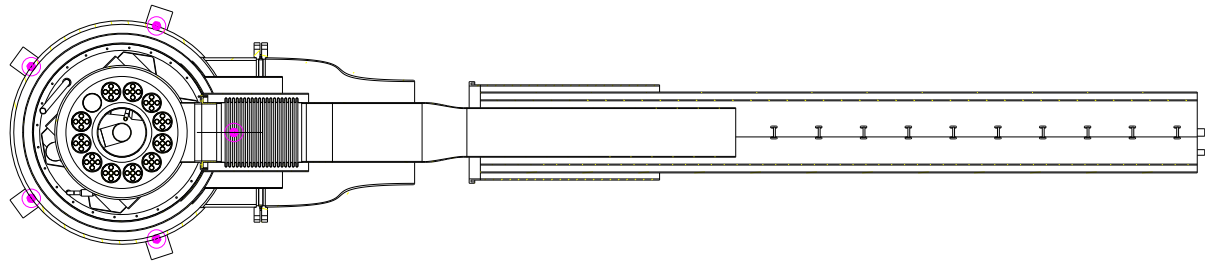

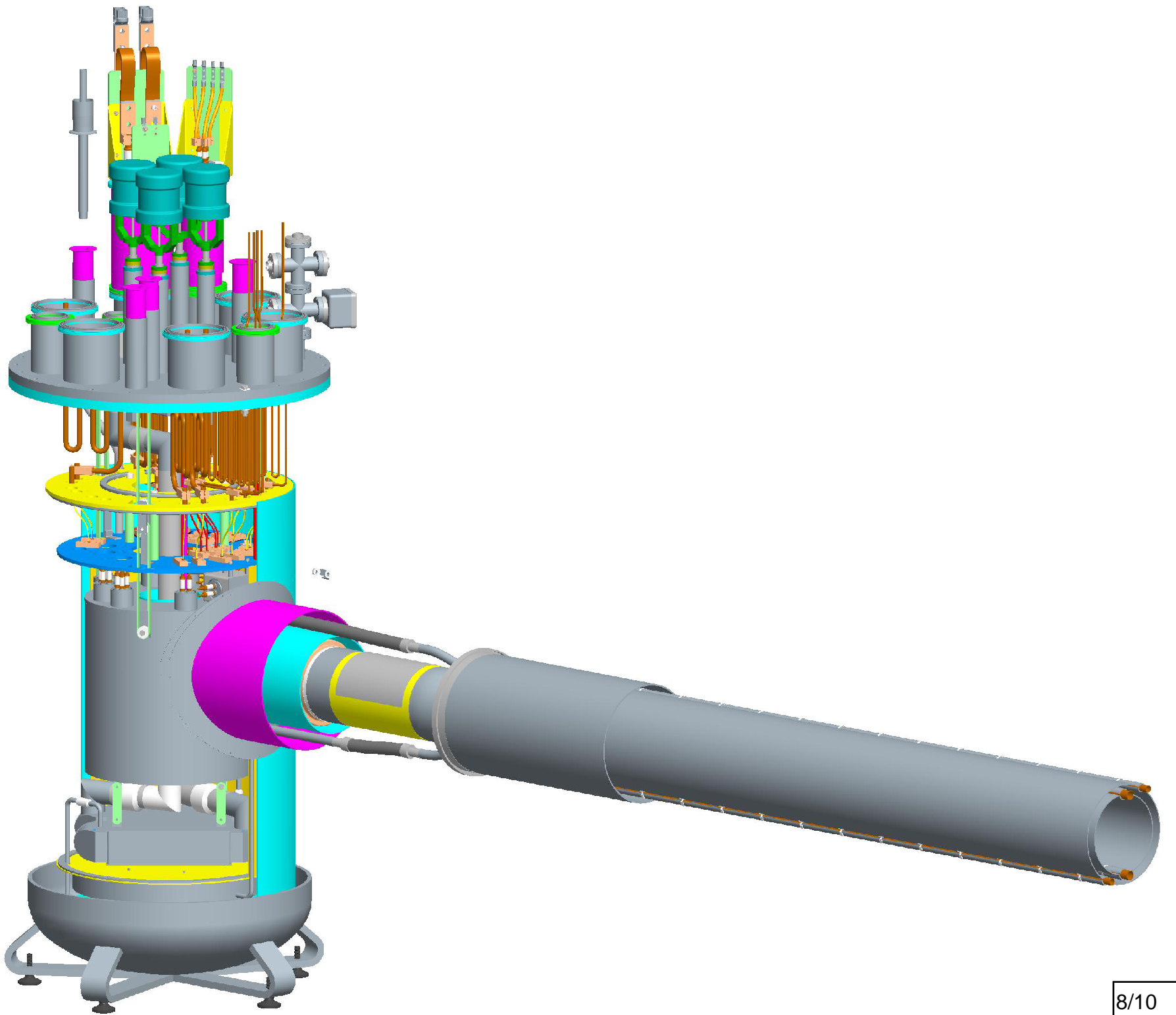

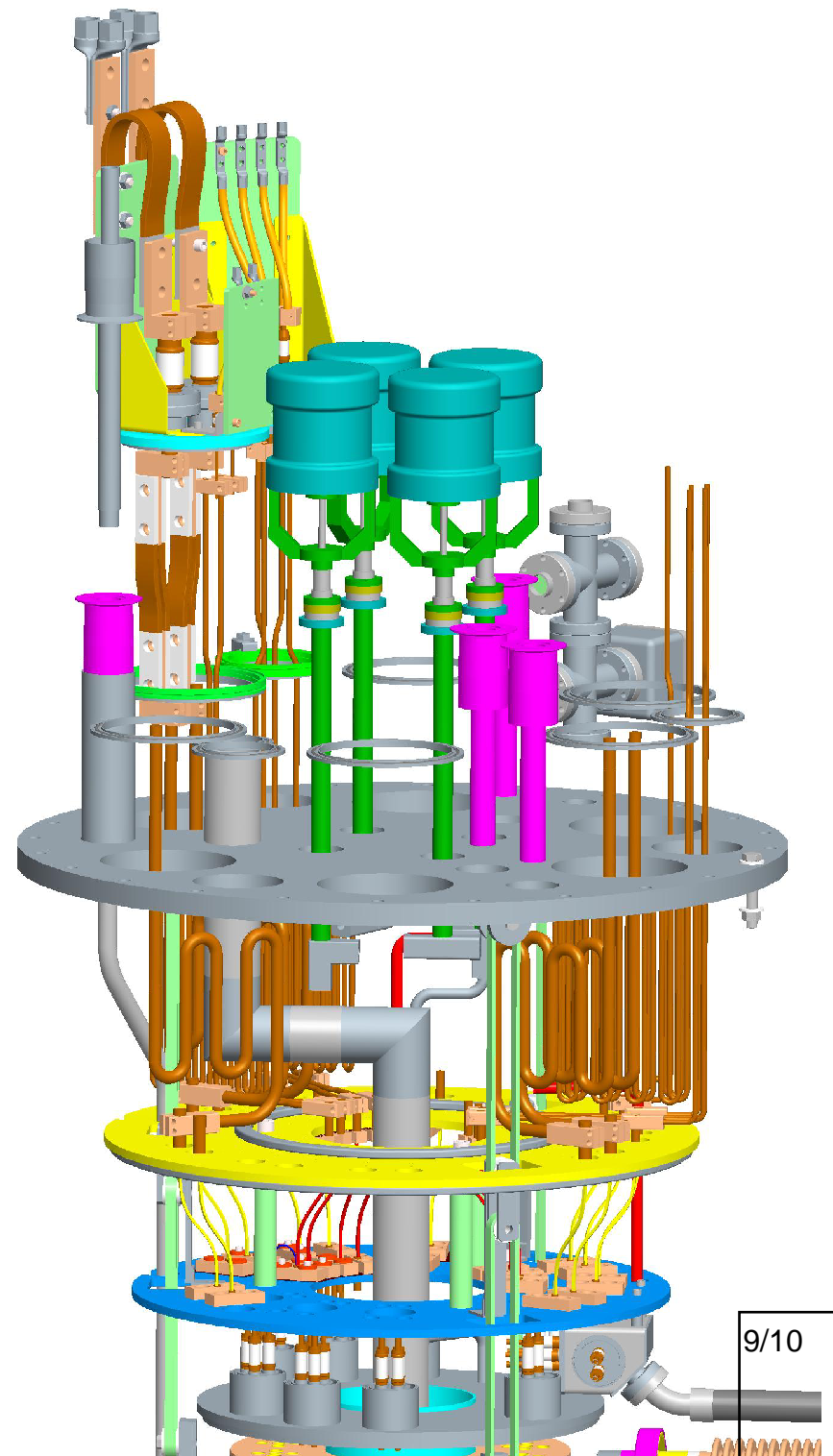
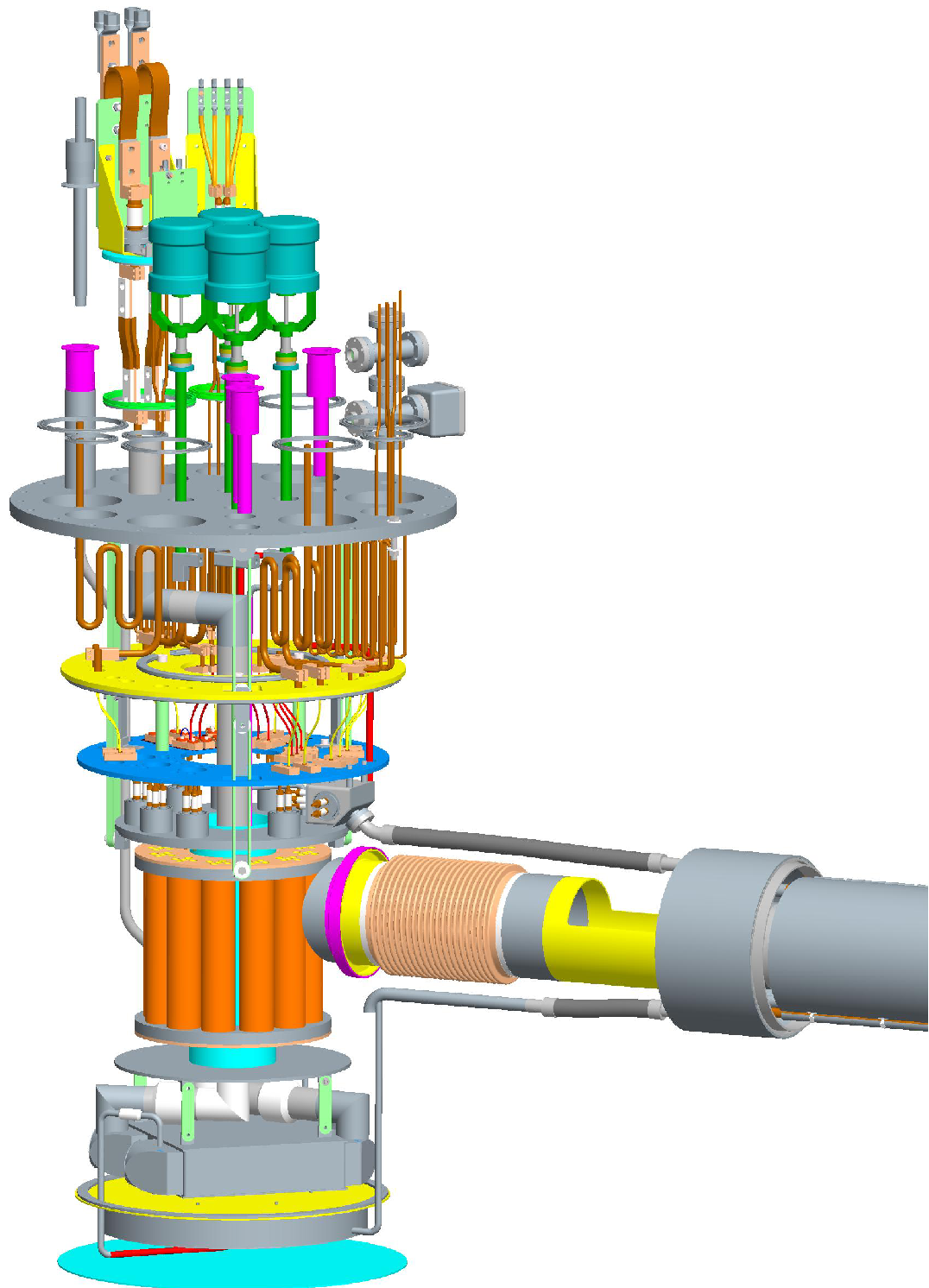

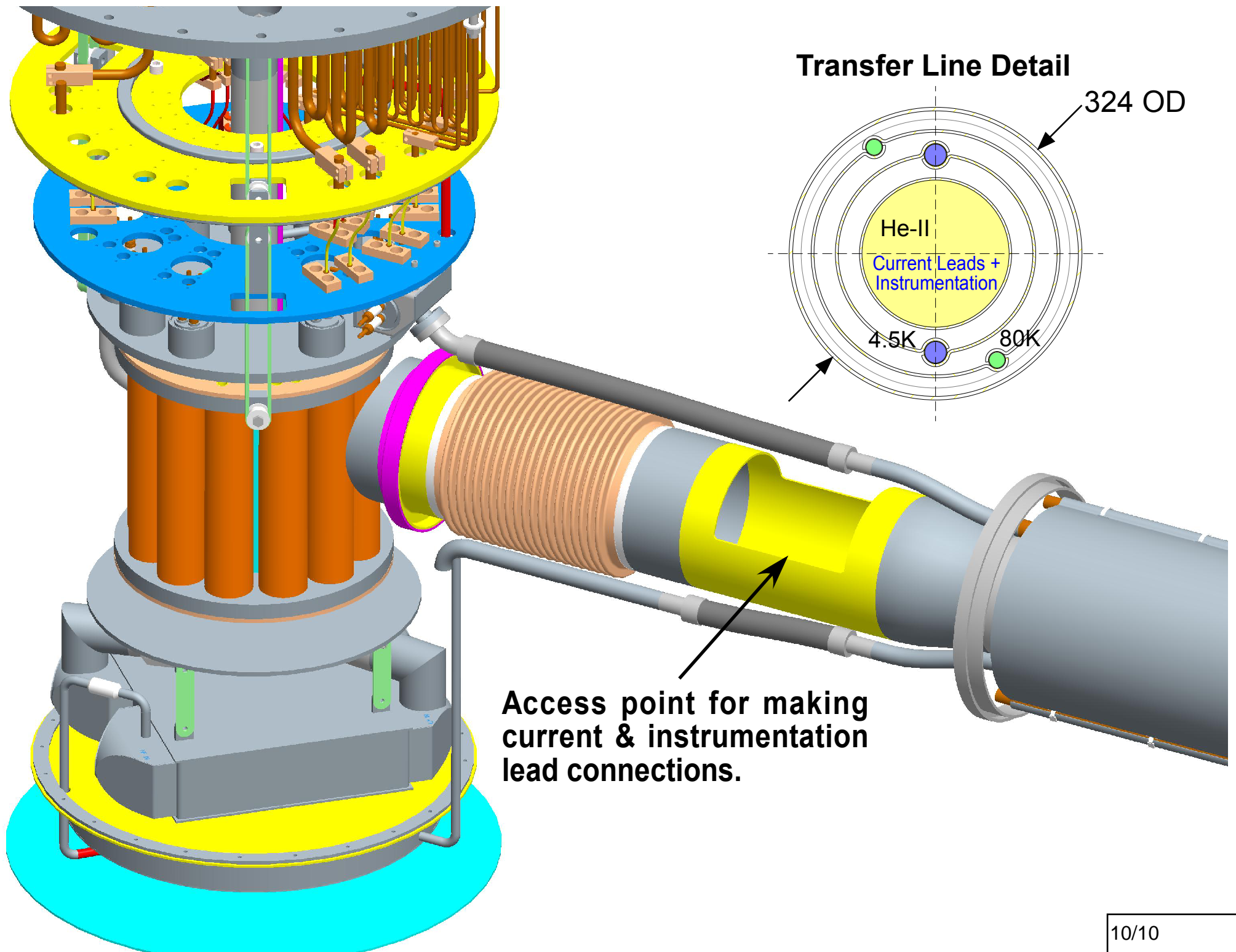

Transfer Line Detail

324 OD

He-II

Current Leads +
Instrumentation

4.5K

80K

**Access point for making
current & instrumentation
lead connections.**