

# GLD-DOD: Magnetic forces 18,000 t !

Iron structure 16,000t ( 7,500t barrel and 6,500t endcap)

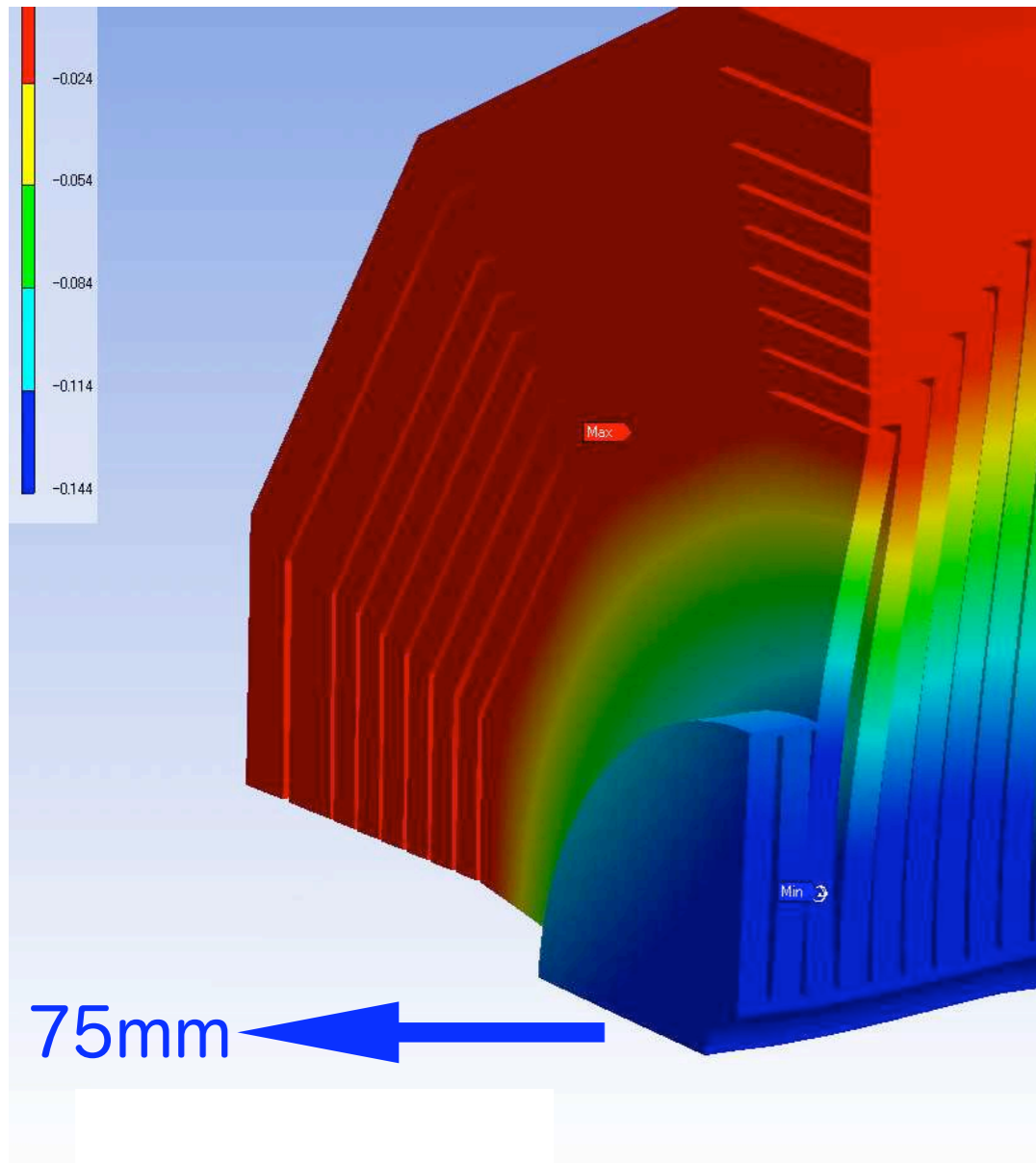

with no “75mm<sup>t</sup> plates”

gravitational sag in barrel yoke = 1.8mm

seismic movement with 0.3G = 2.8mm (horizontal)

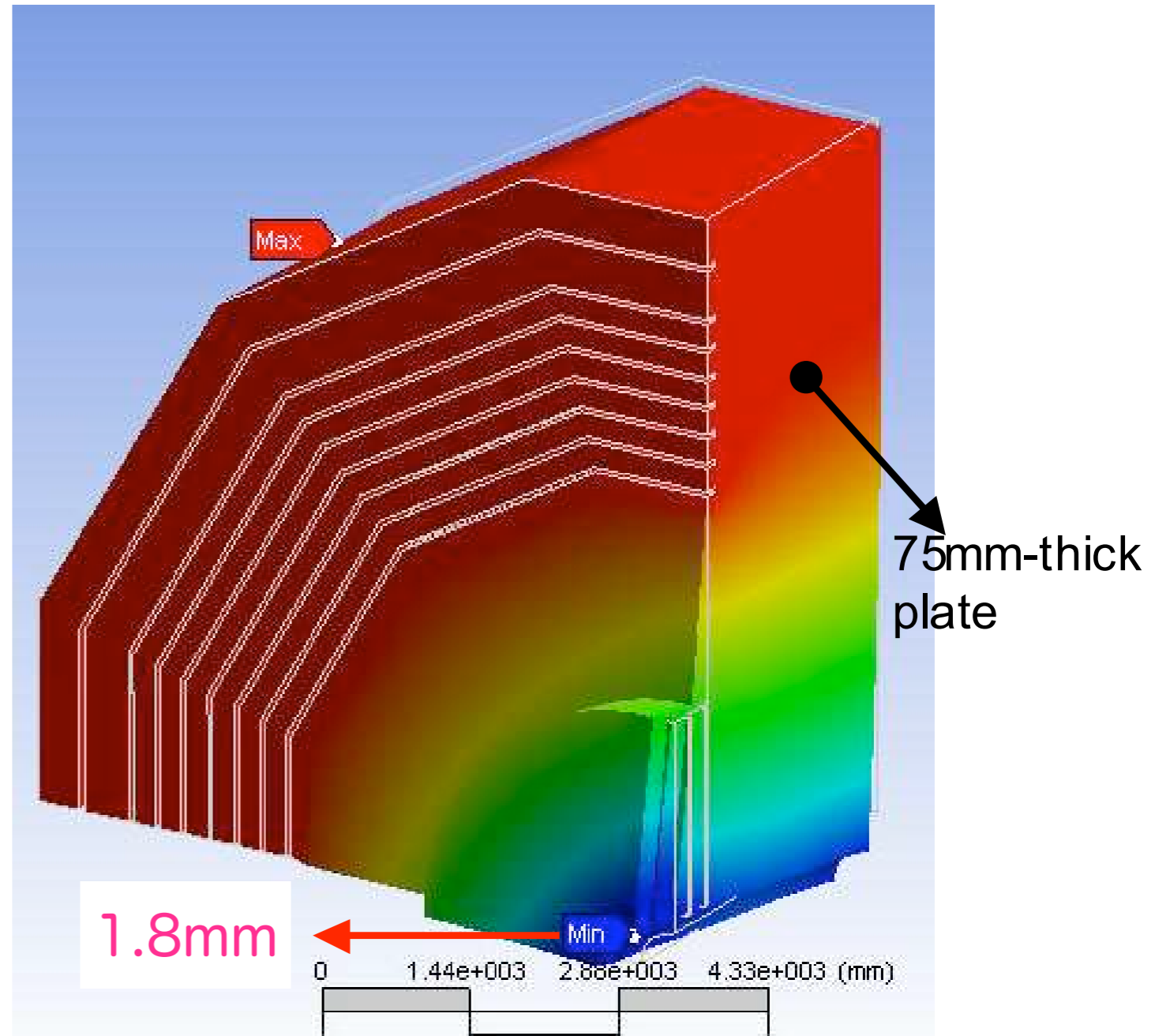

with “75mm<sup>t</sup> plates” in every 90°