

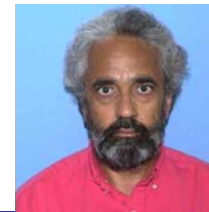

RDR Update



Vinod K. Bharadwaj

SLAC

October 8, 2007





E+ PRODUCTION – DRIVE BEAMS

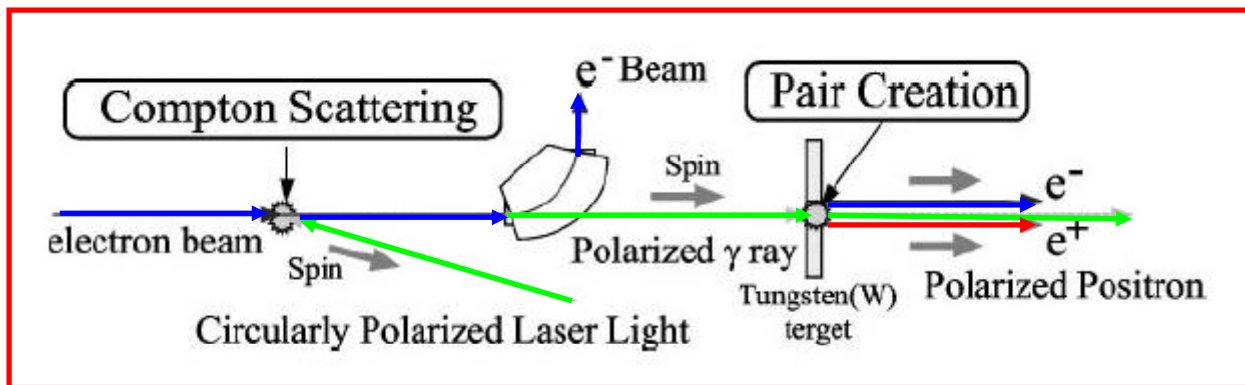
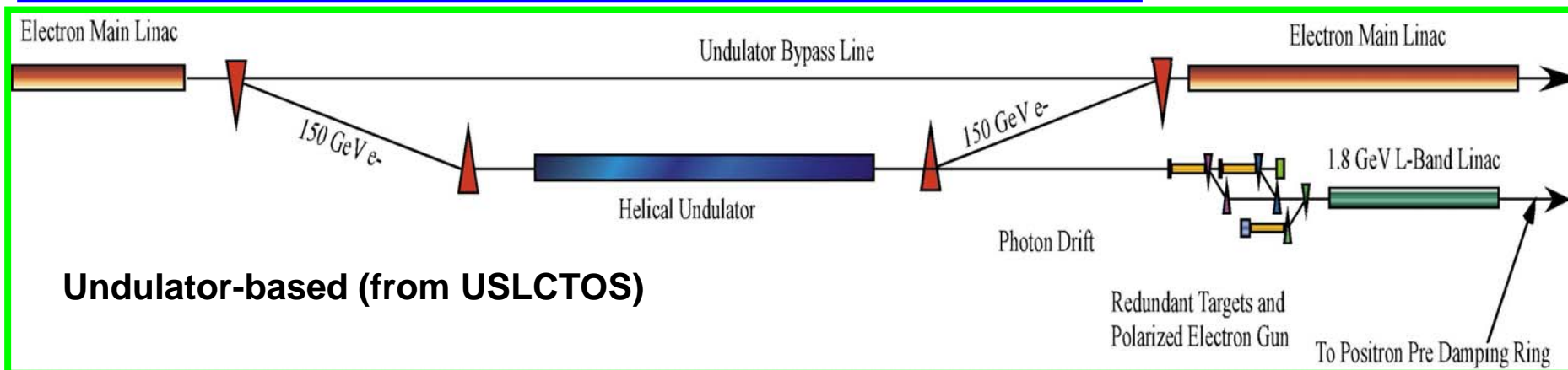
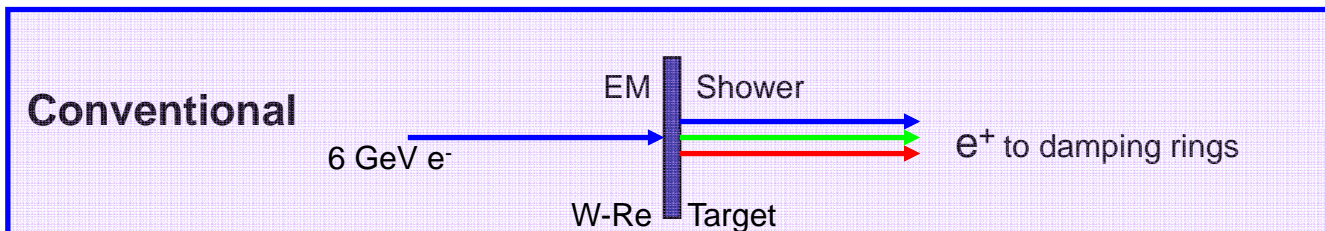
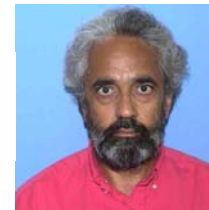

Undulator & Compton allow for polarized positron beams



UNDULATOR BASED E+ SOURCE

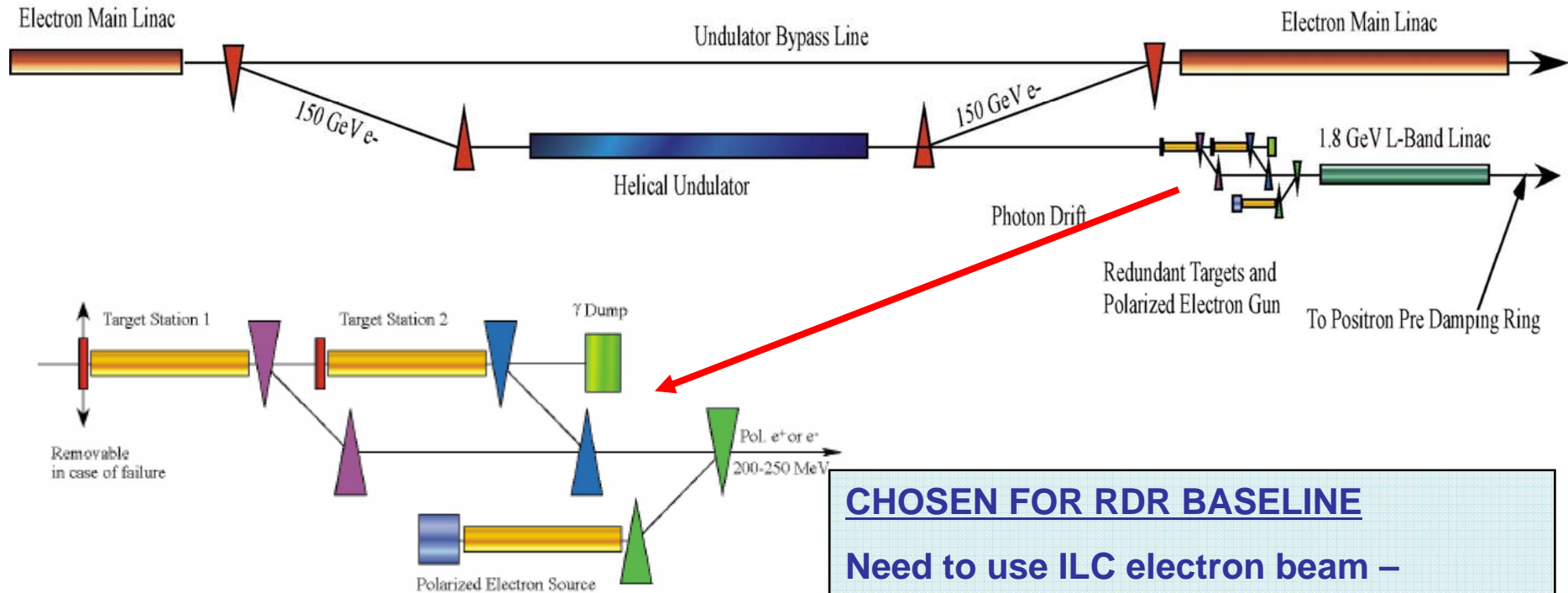
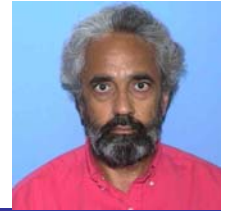

5 GeV Damping Ring Energy
Only one target station
Keep-Alive Source added

CHOSEN FOR RDR BASELINE
Need to use ILC electron beam – possible reliability, machine development and commissioning issues
Can use electron source for commissioning
Long helical undulator, small aperture



Positron Source Layout

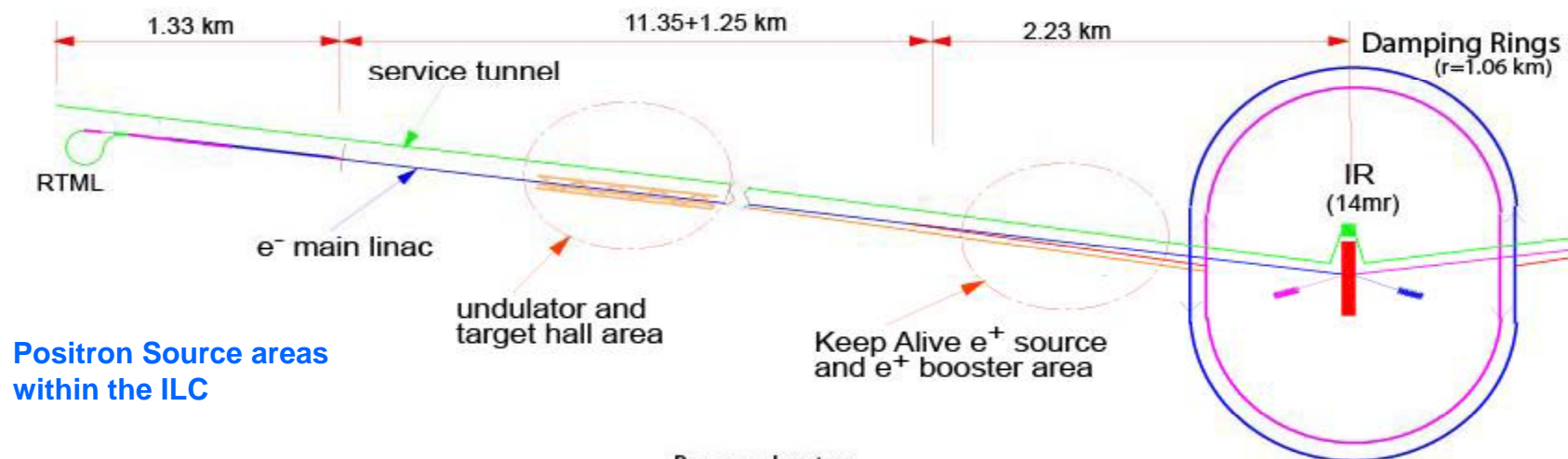
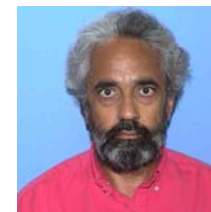

Positron Source areas within the ILC

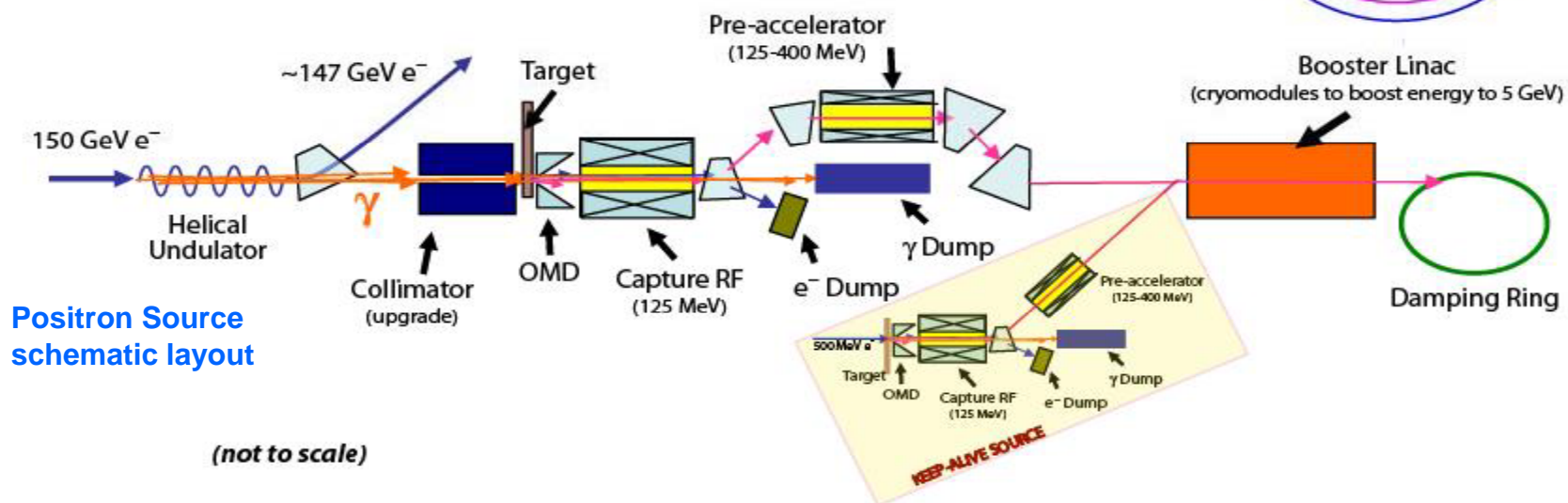

Positron Source schematic layout

(not to scale)



RDR Baseline - US Institutions

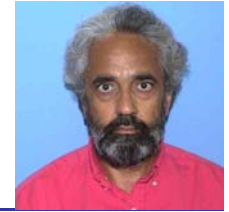

- Institutions doing substantial work on ILC e+ development
 - SLAC
 - overall coordination & leadership
 - define parameters
 - target hall, remote handling, activation
 - beamline optics and tracking
 - NC L-Band accelerator structures and RF systems
 - Experiments – E166, FLUKA validation experiment
 - LLNL
 - target simulations (thermal hydraulics and stress, rotodynamics, materials)
 - target design (testing and prototyping)
 - pulsed OMD design
 - ANL
 - optics
 - tracking
 - OMD studies
 - eddy current calculations
 - Cornell
 - undulator design, alternative target concepts



RDR Baseline - European Institutions

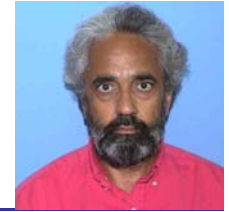

- Institutions doing substantial work on ILC e+ development
 - CCLRC-Daresbury
 - undulator design and prototyping
 - beam degradation calculations
 - CCLRC-RAL
 - remote handling
 - eddy current calculations
 - target hall activation
 - had to stop work mid-stream because of funding issues
 - Cockcroft and Liverpool University
 - target design and prototyping
 - DESY-Berlin
 - target hall activation
 - spin preservation
 - photon collimation
 - E166

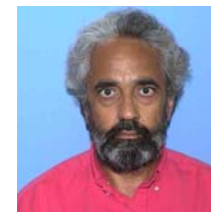
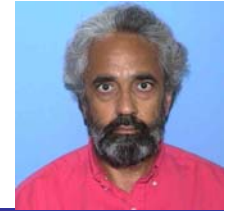

TABLE 2.3-1
Nominal Positron Source parameters ([†] upgrade values).

Beam Parameters	Symbol	Value	Units
Positrons per bunch at IP	n_b	2×10^{10}	number
Bunches per pulse	N_b	2625	number
Pulse repetition rate	f_{rep}	5	Hz
Positron energy (DR injection)	E_0	5	GeV
DR transverse acceptance	$\gamma(A_x + A_y)$	0.09	m-rad
DR energy acceptance	δ	± 0.5	%
DR longitudinal acceptance	A_l	$\pm 3.4 \times \pm 25$	cm-MeV
Electron drive beam energy	E_e	150	GeV
Electron beam energy loss in undulator	ΔE_e	3.01	GeV
Positron polarization [†]	P	~ 60	%



- RDR “proof-of-principle” design – know how to design or get around any issues.
- EDR needs a **realizable** design **now** so that system engineering and **system optimization** can be done in the next three year and a **sturdy** mechanism to introduce any changes
- In good shape
 - optics, most beamlines, most magnets
 - NCRF SW prototype built
 - Undulator design
 - SCRF (if it works for ILC ... we can even use XFEL cavities)
- Needs work
 - Target & capture
 - Target hall & remote handling
 - Positron beam collimation, photon collimation before target, photon collimation in undulator
 - 150 GeV chicane
 - Magnetic design optimization
 - Upgrade path
 - Effect on electron beam – both bends and undulator
 - NCRF SW works at low power levels, do we need a TW prototype
 - Do we need the Keep Alive Source
- More details
 - Spin preservation – is it explicitly needed in design because of the 30% e+ polarization
 - Collimation needs and collimator design
 - Detailed parameters sets, detailed designs, system design
 - Coordination with other systems
- **Alternate designs - resources do not allow us to carry all designs and all ideas forever**

Sacred Cows

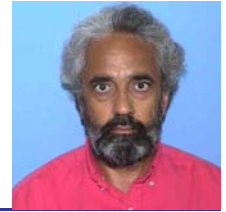

- Different ILC systems behave as completely independent concerns
 - Easier to design large multi-system device
 - Veto power for some system choices in various other groups
 - Maybe more beam dumps that absolutely needed
- Parallel 150 GeV chicane
 - Simplest design
- 2.5-meter 150 GeV chicane offset
 - Assumes that there is linac SCRF parallel to the positron capture
 - Wanted room for shielding between linac and positron target station
 - Did not want to mix linac & positron target design elements
- Undulator not at the end of the linac
 - Low energy ILC running at full luminosity
 - Did not want to mix BDS & positron target elements
 - Backgrounds at the IP
- Keep-Alive Source
 - Not suggested or favored by anyone in the positron source collaboration
 - Increased ILC availability assuming no attempt is made to “harden” positron source to reduce failure modes
 - Increased comfort level for people strongly favoring a conventional positron source
- 50% positron over-production (3×10^{10} at DR injection)

Target & Capture

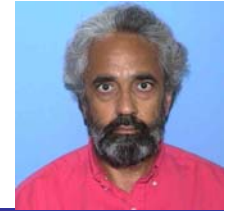

- Best capture – immersed target & “adiabatic field”
- Target must move to survive
- What is the optimum photon beam spot size
- Target damage calculation
- Are we considering overhead/ safety factors properly

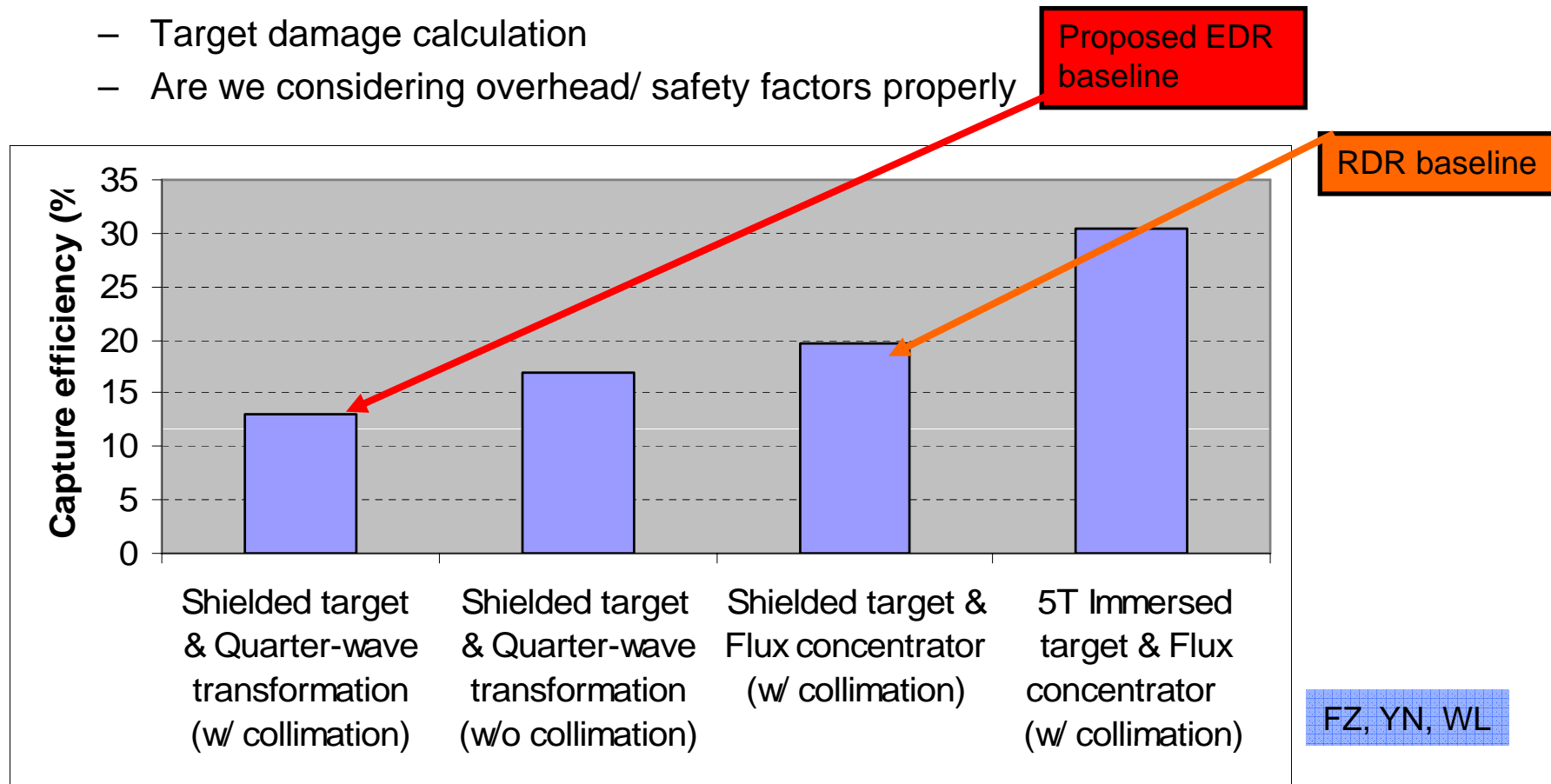

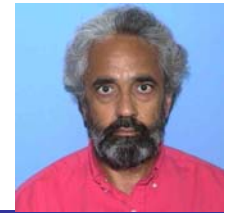

- Target – **still a big deal, not quite a done deal**
 - Has to move fast - 100 m/s rim speed (SLC ~ 0.1 m/s) **beam thermal load (900-> 24J/gram)**
 - Larger wheel (1-m diameter, spins fast - 2000 rpm) **set by radiation damage estimate**
 - 1.4 cm target thickness (0.4 radiation lengths) **fairly much optimized for max e+ yield**
 - Ti-6%Al-4%V (any better alloy – stronger, good thermal, bad electrical conductivity)
 - 8% heat deposition (24 kW for 300 kW, ~ 1 mm incoming photon beam)
- Stress from motion , stress from heating
 - How close to failure should we run
- Vacuum seals that allow water flow and rotation
 - spec sheets indicate that this is not problem, “guts” are nervous
- Magnetic fields (5T best/worst case) & moving metal
 - If we can move target in the magnetic field, there are big gains in efficiency and OMD design
- **Alternate target concepts, capture magnet**
 - Liquid metals
 - W-Re
 - Ceramics
 - Graphite
 - Liquid lithium lens
 - Window after target
 - Alternate target geometries
- **STILL PROBLEMATIC after all these years**
 - **EITHER** not reliably calculated
 - **OR** do not live up promise

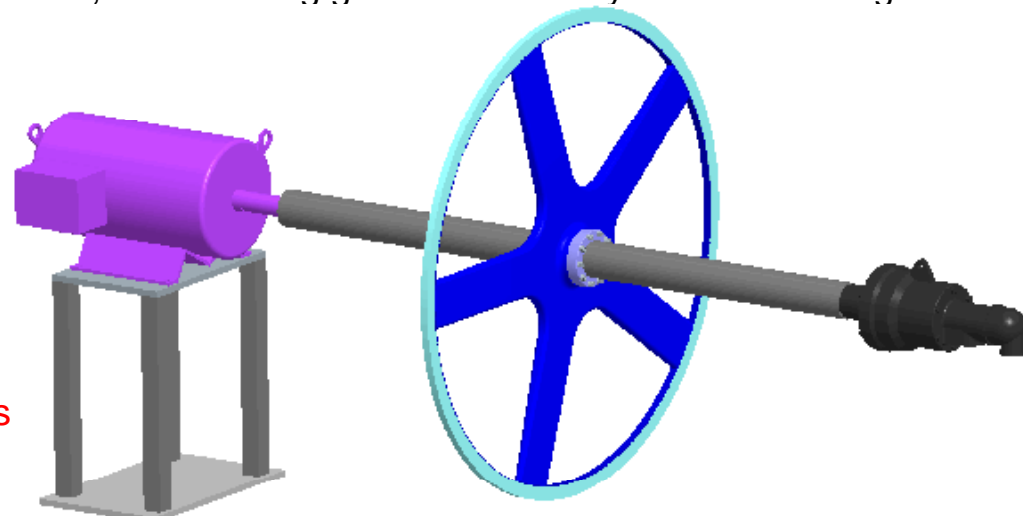



Moving target: Eddy Current Modeling

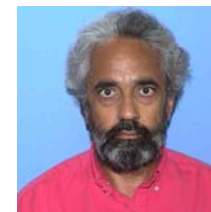

Energy loss is still a challenge

Slice: Resistive heating, time average [W/m^3]

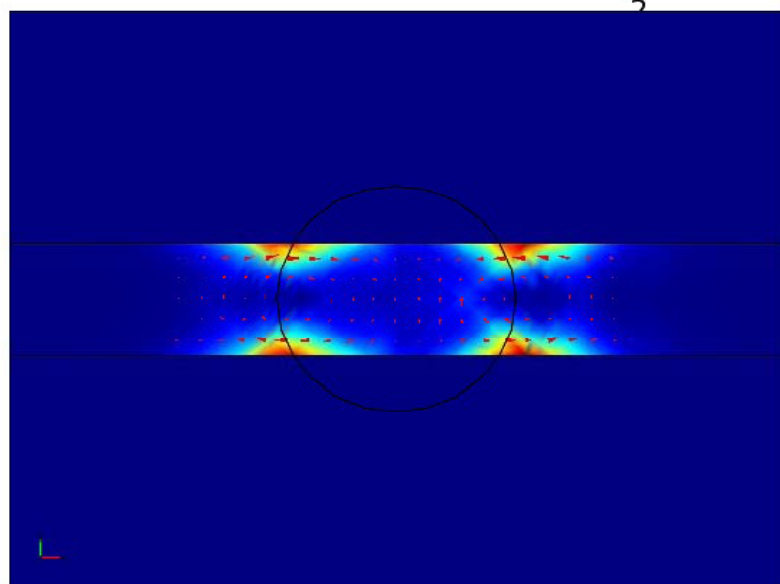

Max: 4.615×10^9
Min: -9.701×10^{-11}

- 150kW @
 - 3.1T
 - 100 m/s
 - 1.5 x 5.5 cm
 - 6.9×10^5 1/ohm/m
- Scales as expected to
 - 15kW @ 1T
 - May be livable at this field

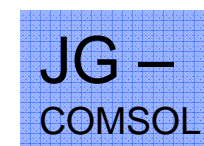

J. Gronberg - LLNL

August 15, 2007 positron target meeting

6

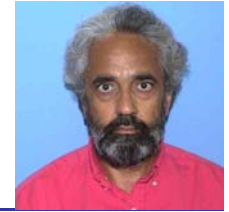

Spot Size Comparisons- von Mises Stress

Larger spot size better for many reasons

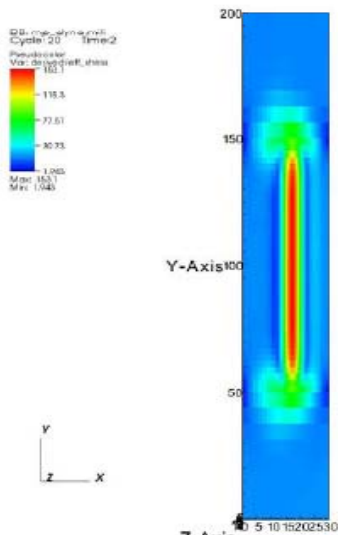

Sigma=1.7 mm
 $\sigma_{\max} = 153.1 \text{ MPa}$

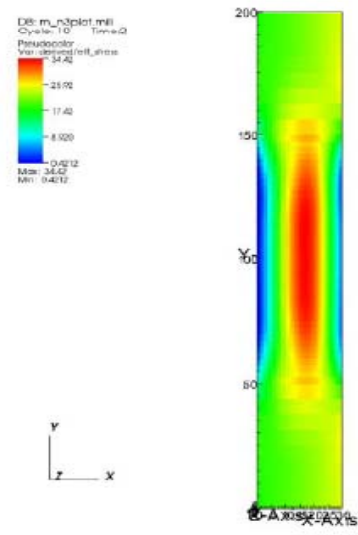

Sigma=3.4 mm
 $\sigma_{\max} = 34.42 \text{ MPa}$

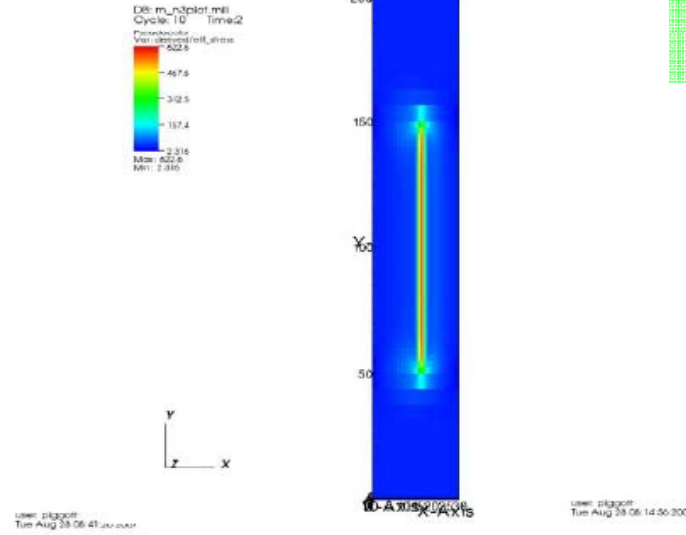

Sigma=0.85 mm
 $\sigma_{\max} = 622.6 \text{ MPa}$

TP



Spot size & Capture Efficiency

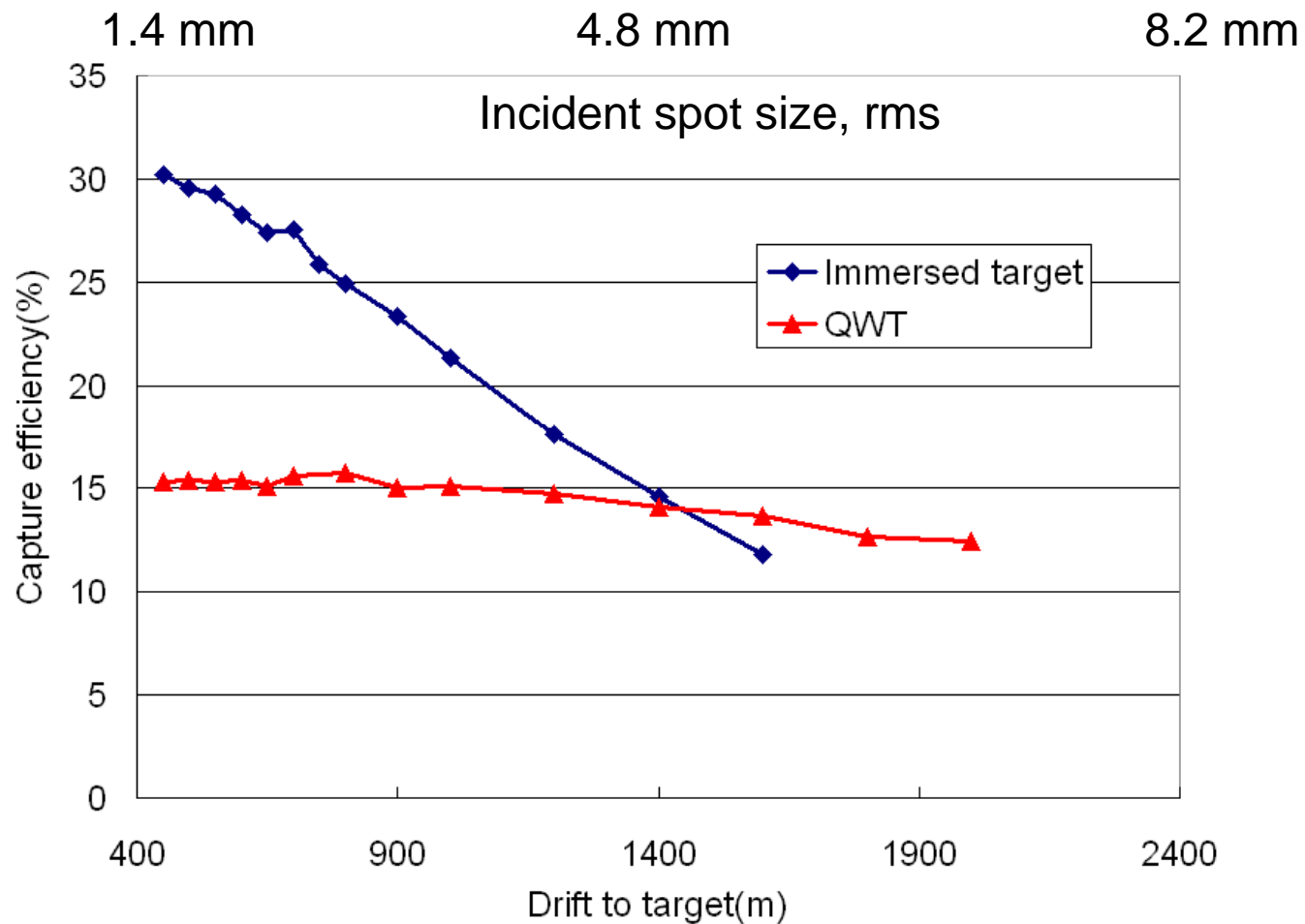
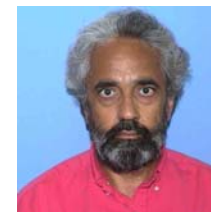

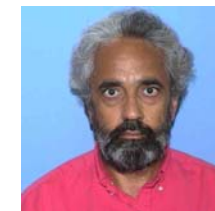

Ti-alloy and W-Re Target Energy Deposition Numbers

W. Liu, T. Piggott, and J. C. Sheppard

Rev. 7: August 24, 2007

Assuming a gaussian transverse spatial distribution of undulator photons incident to a spinning target annulus of Ti-alloy, what are the values for the deposited energies, energy densities, stresses, and peak and average temperature rises in the target? How do these values change with variations in the incident beam energy and size and tangential target velocity? What is the “safe” engineering limit of the incident beam intensity?

Comparison for different capture efficiencies:

+ Table 5:

Parameter					Units
Target Material	<u>TiAlV</u>	<u>TiAlV</u>	<u>TiAlV</u>	<u>TiAlV</u>	
Incident Spot Size	1.7	1.7	1.7	1.7	mm
Capture Efficiency	13	16	20	30	%
Number of photons per electron	577	469	375	250	γ/e^-
Undulator Length	303	246	197	131	m
Average power deposition	20	16	13	9	kW
Peak temperature rise	117	95	76	50	$^{\circ}\text{K}/\text{pulse}$
Peak compressive stress, TE	113	92	74	49	<u>MPa</u>



Target Hall/Remote Handling

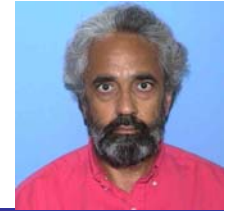

- Target hall
 - How big
 - How much underground
- Do we need remote handling?
 - Target hall activation field
 - We have some numbers for the target (100 R/hour range)
 - Need to do much more realistic calculation for the whole setup. Exercise useful for other questions (SC solenoids around the RF?)
 - Do other ILC facilities need radioactive mechanical work and is there any overlap
- Collaboration with [ORNL](#) for RH design?
 - [SNS](#) (Graeme Murdoch - Nuclear Facilities Development Division, Deputy Director & Engineering Group Leader)
 - To busy to help in design, can help with reviews etc.
 - (they are trying get ORNL LDRD funds for rotating target!)
 - [Nuclear Science and Technology Division](#) (Tom Burgess – Fuels, Isotopes, and Nuclear Materials/Remote System Group)
 - Help with design, need to be funded at some level



Target Hall/Remote Handling

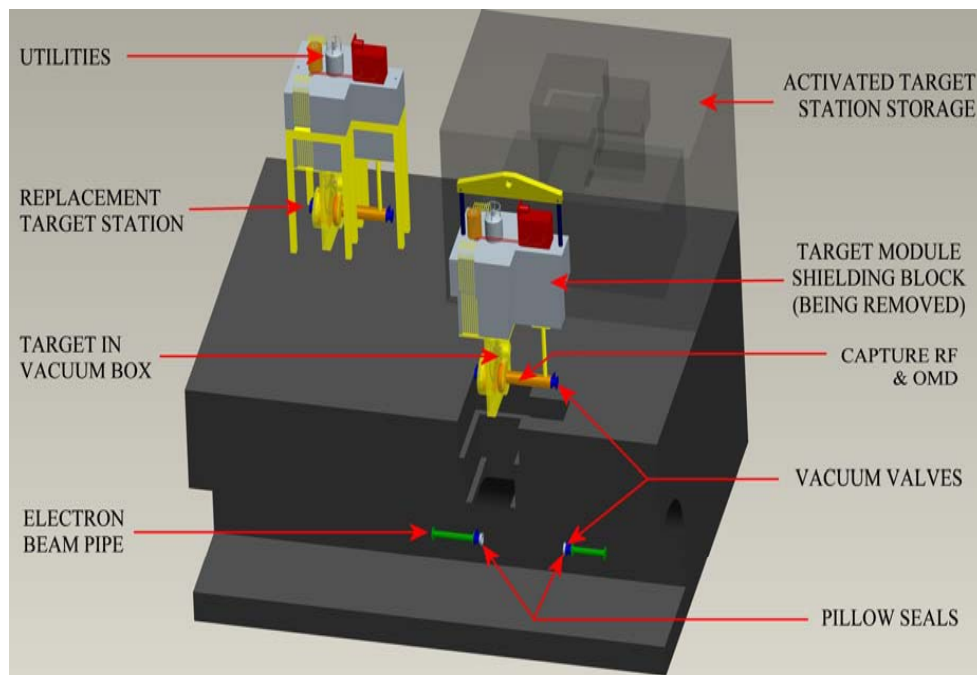
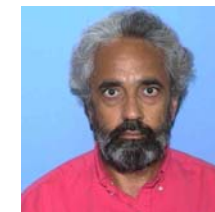

Target station deep underground
Excavation costs volume dependent

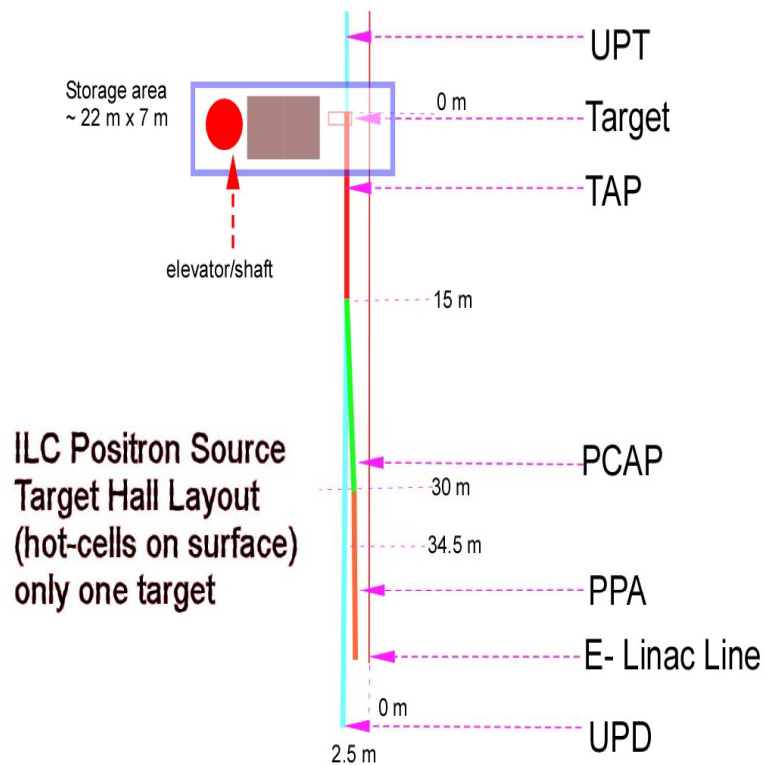

Mini-hall concept



Target Hall/Remote Handling

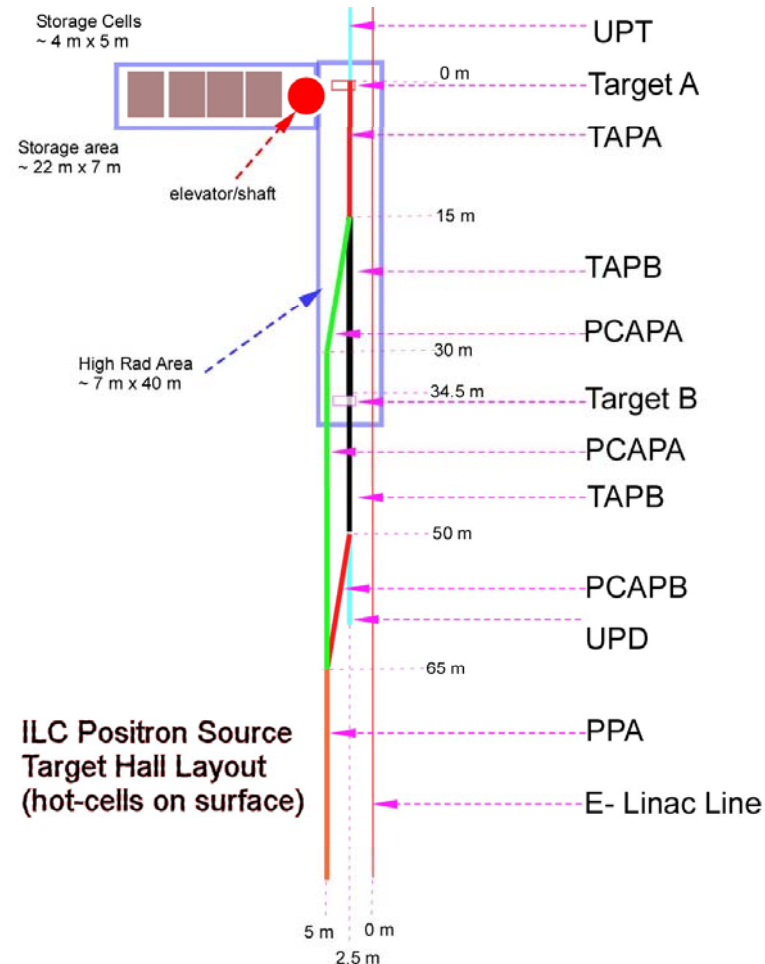
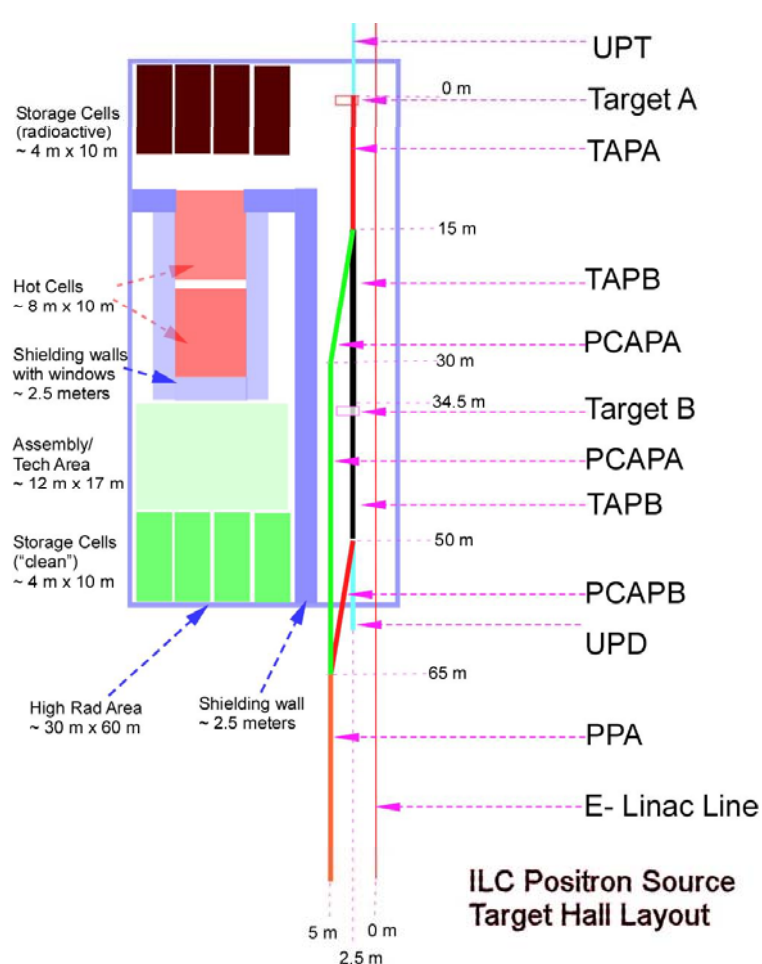
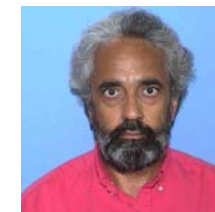

Maybe we will need more area underground

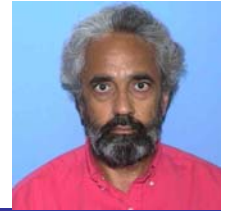

- Not really mentioned in RDR
- Only 10-30% of the beam coming out of the target is captured in the damping rings
- We need a system of collimators to localize beam loss and activation
- Better to collimate at lower energies
- Some collimation optics have been designed
 - How much more work is needed for optics design
 - Can we cross-check anything
 - Do we need R&D to make any of the collimators
 - What are the minimum feasible losses in the DR
 - Do the DR's have any loss requirements
- Photon collimation
 - Before target
 - Inside the undulator



Collimation – beam losses

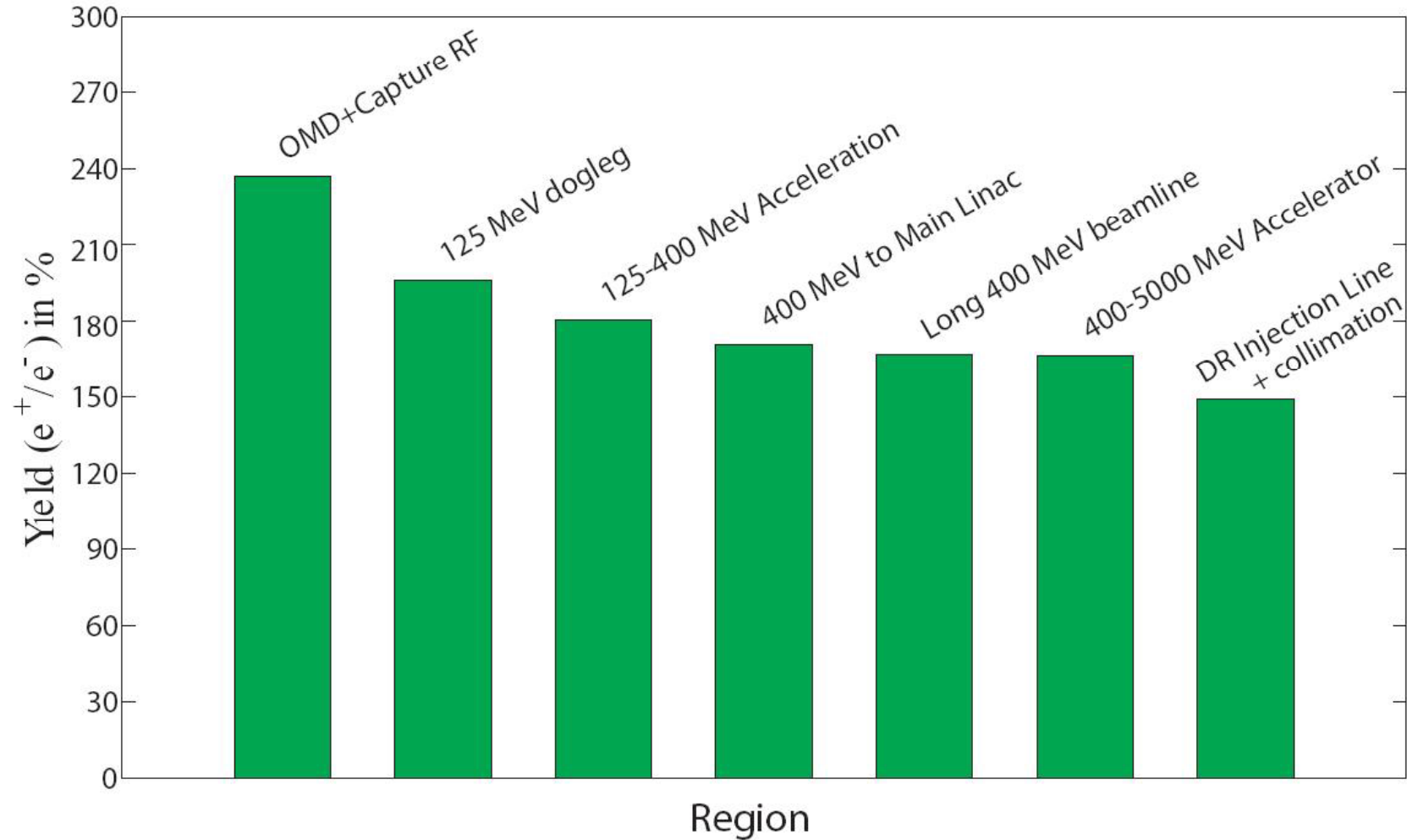
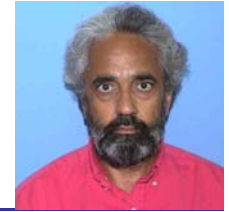

150 GeV Chicane

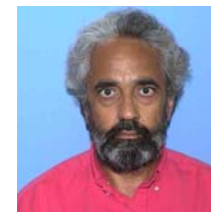

- Nominal design
 - Undulator parallel to linac line
 - 2.5 meter offset
 - needed for target station
 - needed for beam dump
 - Needed for linac
 - Total length > 1200 meters for a few hundred meter undulator
 - 2.5 meter offset achieved with 250 meter arcs ~ 10mr bend
 - Electron beam quality going through chicane is OK
 - Need to quantify all the beam effects
 - Beam energy upgrade problematic
 - Needs to ensure that all engineering end effects are included
- Are there alternative designs that are better
 - Non-parallel undulator line
 - Do we really need 2.5 meter offset
 - End of the linac location
- How do we upgrade in energy
 - Should we worry about this for the EDR
 - Scale bends
 - Longer chicane/shallower bends
 - New location

Location	start (meters)	end (meters)	length (meters)
End of 150 GeV linac	0	0	
MPS + matching	0	237.804	237.804
Bypass bend-to-bend	237.804	486.624	248.82
Bypass emit meas	486.624	540.624	54
Bypass extra before U	540.624	577.894	37.27
Undulator region	577.894	868.654	290.76
Bypass extra after U	868.654	905.914	37.26
Bypass bend-to-bend	905.914	1154.734	248.82
Bypass matching to L	1154.734	1177.966	23.232
Emittance measurement	1177.966	1232.344	54.378
Acceleration for Und loss	1232.344	1376.344	144



“3-magnet” bump

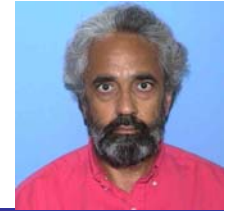

- Present scheme (10 mr bends) uses 112 bend magnets, each 2.25 meters long for chicane for 2.5 meter offset of photon beam to the linac line
- Propose 1 mr bend scheme
 - Use only 12 dipole magnets
 - 500 meters of drift separates photons by 85 cm from linac line
 - Other leg can be filled with SCRF or left for possible second photon line
 - Effects on electron beam reduced and upgrade to 400 GeV not as problematic
 - Design of linac beam through target hall integrated into the target station design
 - Strait through electron beam problematic

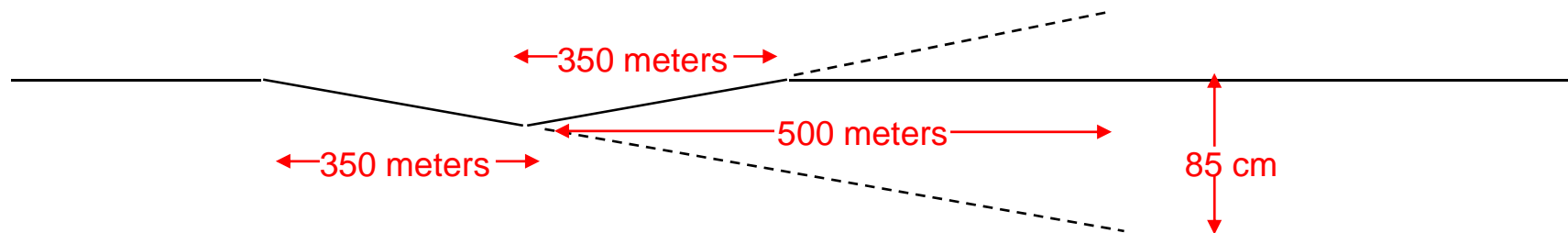



Keep-Alive Source

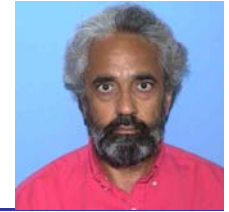

- ~10% positron source, poorly defined in bunch structure/intensity, used to keep feed-backs alive if undulator-based positron source needs repair
- 10% does not make it considerably less complicated or cheaper
 - Target station a little easier
 - Still needs target hall, remote handling etc.
- No significant work done on KAS design in RDR phase
- Talk of “small” positron source for commissioning
 - Not in RDR
 - Same as KAS?

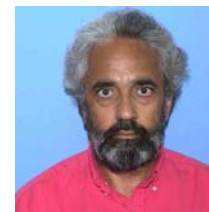

- High gradient cavities just after the target/capture
 - SW 15 MV/m , TW 8.5 MV/m
 - normal conducting (beam losses)
 - Been to deal with heat load from beam
 - Short SW prototype designed and built
 - Need to do high power testing
 - TW prototype ?

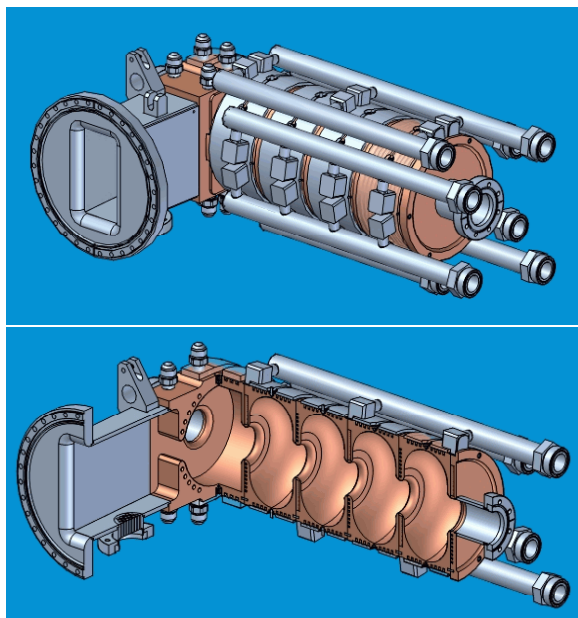
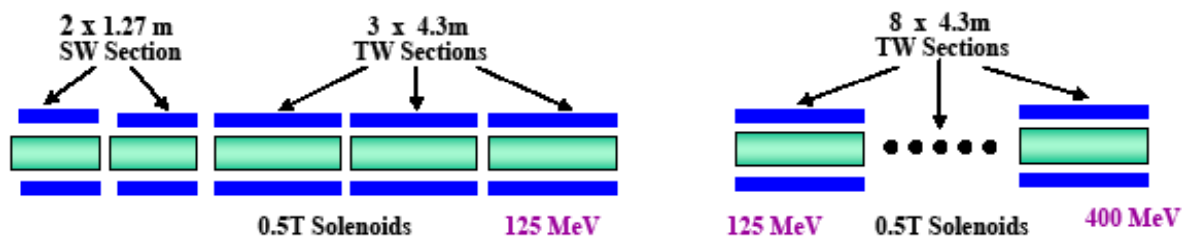

Structure Type	Simple π Mode
Cell Number	11
Aperture $2a$	60 mm
Q	29700
Shunt impedance r	34.3 M Ω /m
E_0 (8.6 MW input)	15.2 MV/m

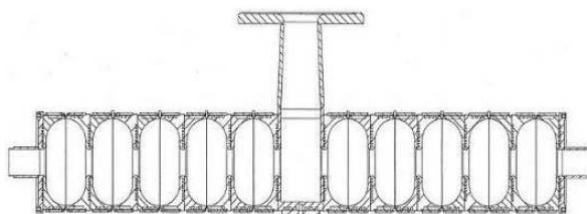
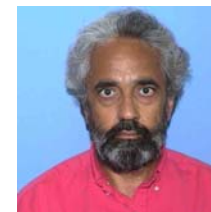

Figure 3: 11-cell SW structure.





Preliminary Microwave Checking



Measurement Setup for the Stacked Structure before Brazing without Tuning

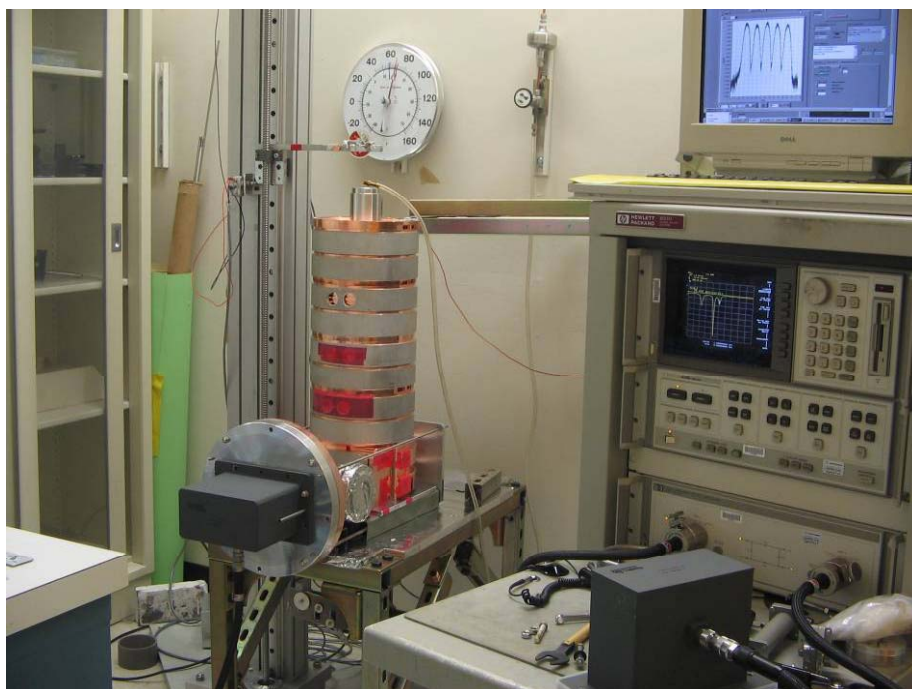

Field Plots for Bead Pulling Two Different Frequencies Showing the Correct Cell Frequency and Tuning Property.

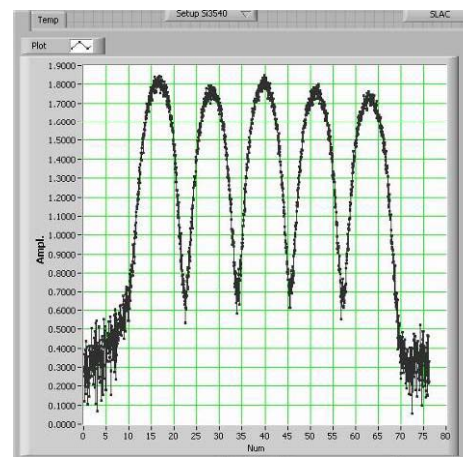

1300.175 MHz
at 20° C, N₂

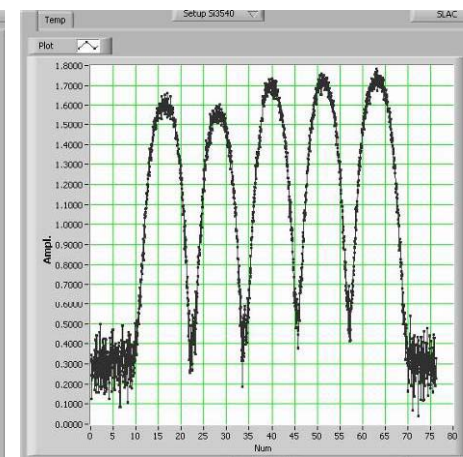

1300.125 MHz
at 20° C, N₂



Brazed Coupler and Body Subassemblies – Ready for Final Brazing

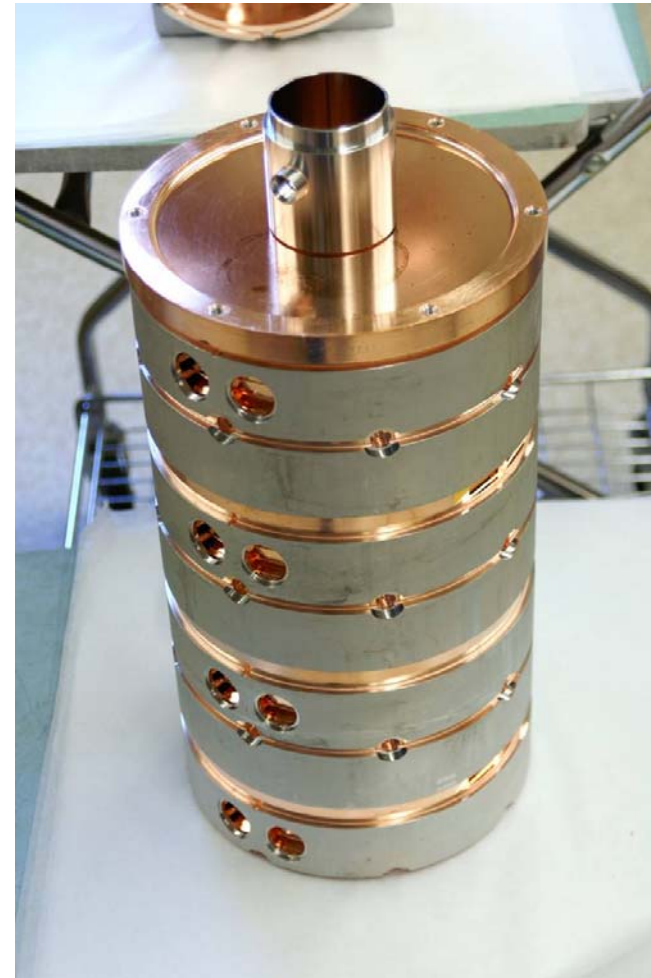
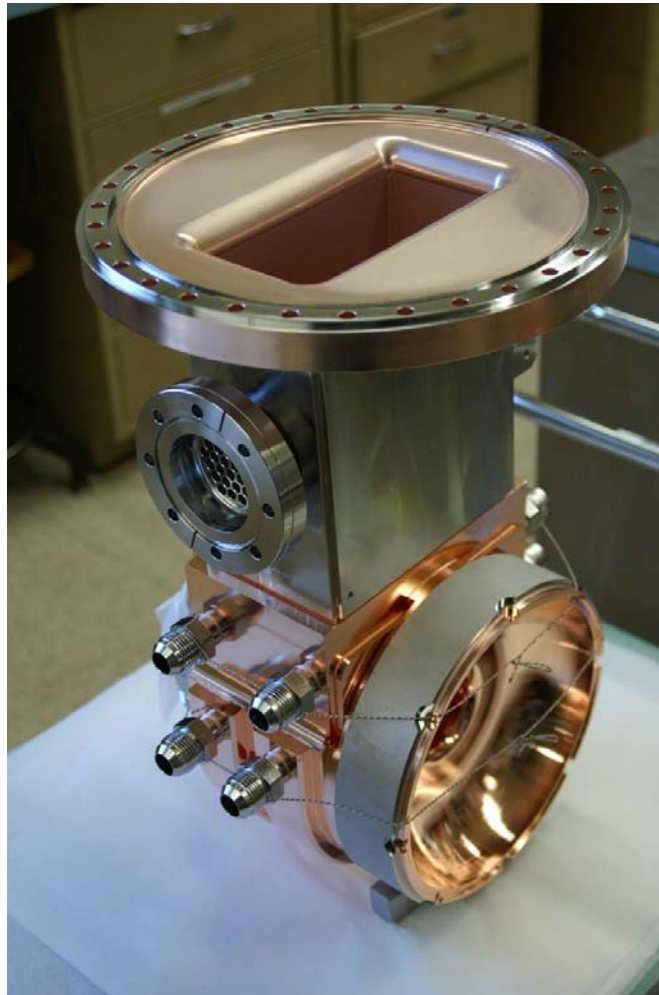
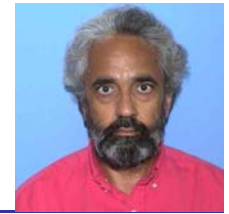



Undulator Challenges

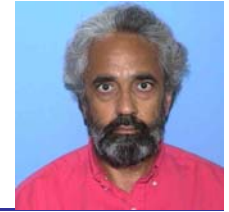

- High fields
 - Pushing the limits of technology
- Short Periods
 - Shorter periods imply higher fields
- Narrow apertures
 - Very tight tolerances - Alignment critical
- Cold bore (4K surface)
 - Cannot tolerate more than few W of heating per module
- Minimising impact on electron beam
 - Must not degrade electron beam properties but have to remove energy from electrons
- Creating a vacuum
 - Impossible to use conventional pumps, need other solution
- Minimising cost
 - Minimise total length, value engineering



4m Undulator Module Prototype Specs

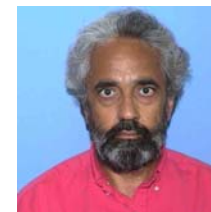

On axis field	0.86 T
Peak to peak variation	<1%
Period	11.5 mm
Nominal Current	~250 A
Nom current as % of Short Sample	80%
SC wire	NbTi 0.4mm dia., SC:Cu ratio 0.9:1
Winding Cross Section	7 wires wide x 8 high
Number of magnets per module	2 (powered separately for tests)
Length of magnetic field	2 x 1.74 m

No Beam Collimators or Beam Pipe Vacuum pumping ports
in the magnet beam pipe



4m Prototype Module

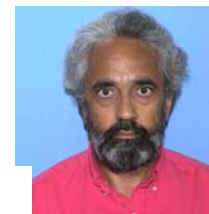

Construction has started, testing will start
October 2007, module complete by April 2008

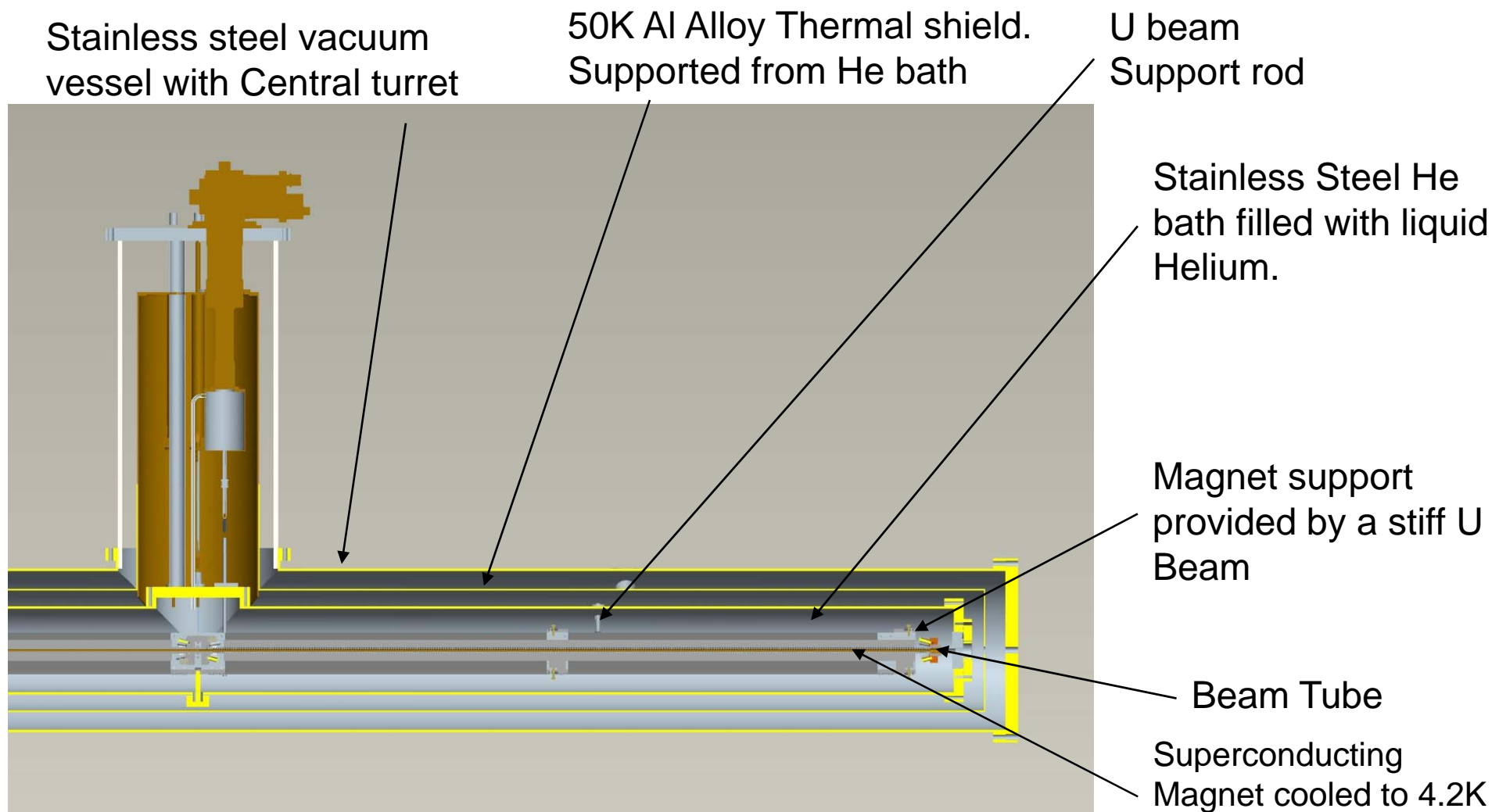

October 8, 2007

Daresbury : Positron Kick-off Meeting

Slide 29



Magnet Design Concept

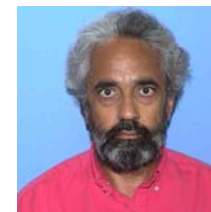

Steel Yoke. Provides 10% increase in field and mechanical support for former

Winding pins

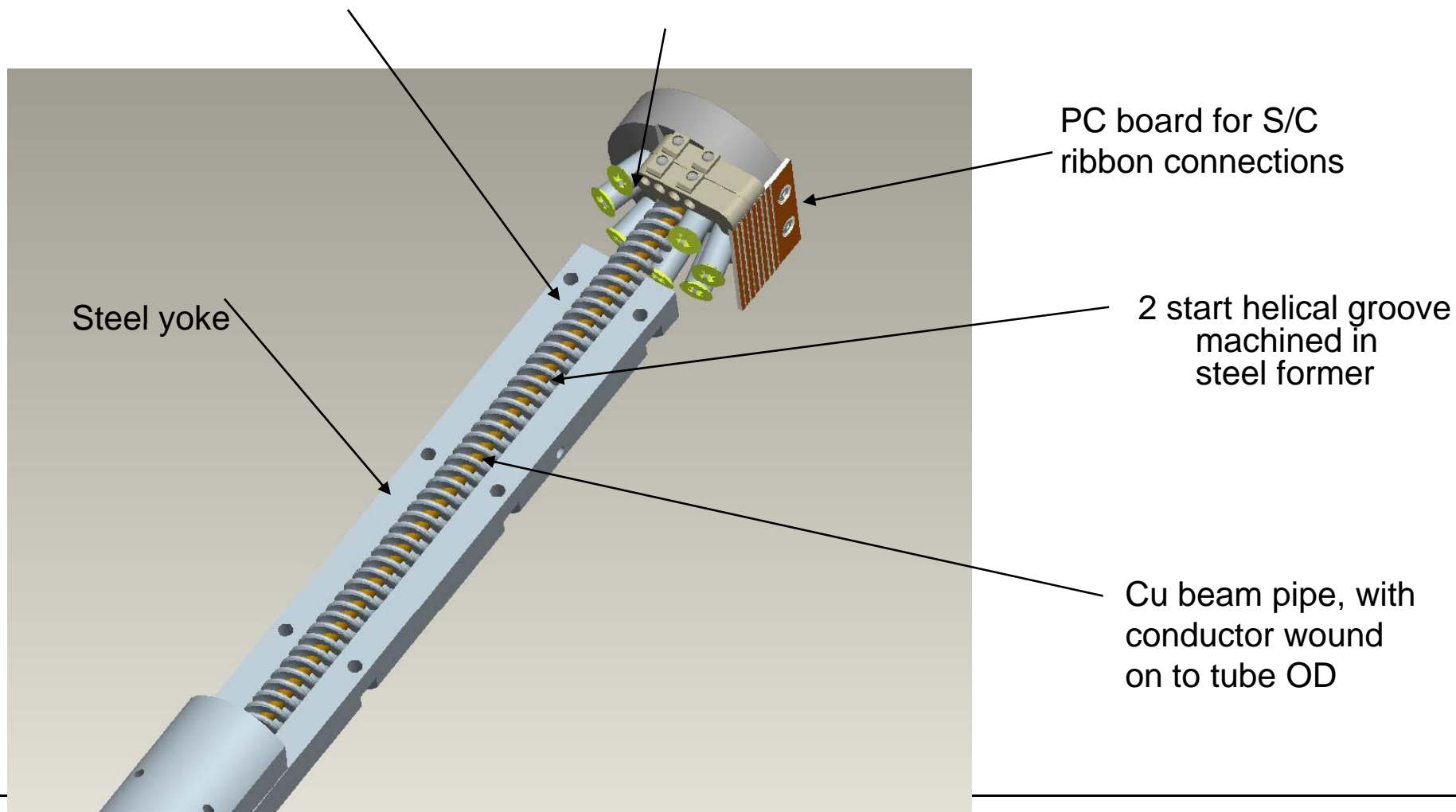

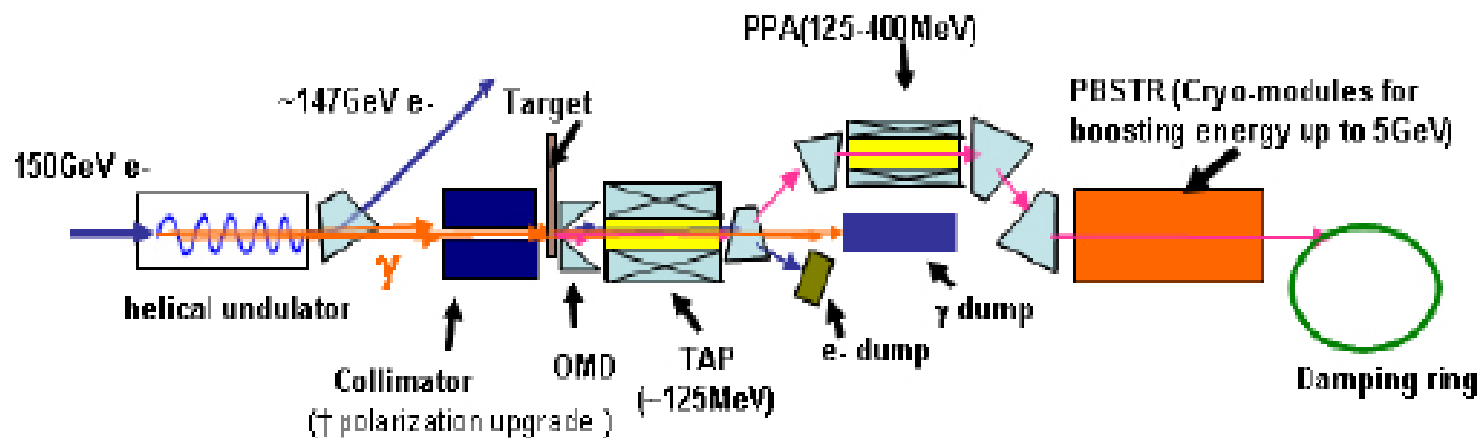
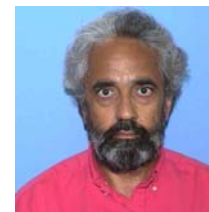

- 150 GeV e- insert chicane: see <http://www.slac.stanford.edu/~yuri/>
- Target to capture system (125 MeV)
- Target hall: 125 MeV dogleg, 125-400 MeV NC pre-acceleration, and 400 MeV dogleg
- 5.03 km 400 MeV transport from e- main linac to e+ booster linac
- SC boost linac to 5 GeV
- Linac-to-Ring: spin rotations, energy compression, and beam collimation.
- Mostly in good shape – Feng Zhou presentation
 - Collimation
 - 150 GeV chicane
 - Make everything fit – flanges, instrumentation etc.

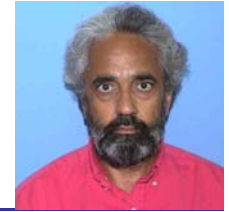

- ILC RDR Positron Chapter:
<http://media.linearcollider.org/report-apr03-part1.pdf> sec. 2.3, pg. 45 ff
- ILC Positron Source Collaboration Meetings
 - 1st meeting at RAL September, 2006: http://www.te.rl.ac.uk/ILC_Positron_Source_Meeting/ILCMeeting.html
 - 2nd meeting at IHEP, Beijing January, 2007 : <http://hirune.kek.jp/mk/ilc/positron/IHEP/>
 - 3rd meeting at Argonne <https://www.hep.anl.gov/ILC-positron/>
- ILC Notes
 1. ILC Target Prototype Simulation by Means of FEM Antipov, S; Liu, W; Gai, W [ILC-NOTE-2007-011] <http://ilcdoc.linearcollider.org/record/6949>
 2. On the Effect of Eddy Current Induced Field , Liu, W ; Antipov, S; Gai, W [ILC-NOTE-2007-010] <http://ilcdoc.linearcollider.org/record/6948>
 3. The Undulator Based ILC Positron Source: Production and Capturing Simulation Study – Update, Liu, W ; Gai, W [ILC-NOTE-2007-009] <http://ilcdoc.linearcollider.org/record/6947>
- Other Notes
 1. F.Zhou, Y.Batygin, Y.Nosochkov, J.C.Sheppard, and M.D.Woodley, "Start-to-end beam optics development and multi-particle tracking for the ILC undulator-based positron source", slac-pub-12239, Jan 2007. <http://www.slac.stanford.edu/cgi-wrap/getdoc/slac-pub-12239.pdf>
 2. F.Zhou, Y.Batygin, A.Brachmann, J.Clendenin, R.H.Miller, J.C.Sheppard, and M.D.Woodley, "Start-to-end transport design and multi-particle tracking for the ILC electron source", slac-pub-12240, Jan 2007. <http://www.slac.stanford.edu/cgi-wrap/getdoc/slac-pub-12240.pdf>
 3. A.Mikhailichenko, " Liquid metal target for ILC*.*". Jun 2006. 3pp.
Prepared for European Particle Accelerator Conference (EPAC 06), Edinburgh, Scotland, 26-30 Jun 2006.
Published in *Edinburgh 2006, EPAC* 816-818



Select Positron References, 2

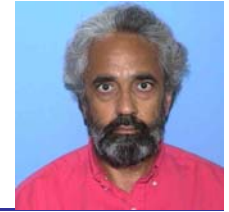

- Other Notes, cont'd

4. A.A. Mikhailichenko <<http://www-spires.slac.stanford.edu/spires/find/wwwhepau/wwwscan?rawcmd=fin+%22Mikhailichenko%2C%20A%2EA%2E%22>>, "Test of SC undulator for ILC.", Jun 2006. 3pp. Prepared for European Particle Accelerator Conference (EPAC 06), Edinburgh, Scotland, 26-30 Jun 2006.
Published in *Edinburgh 2006, EPAC* 813-815.
5. A.Mikhailichenko, "Issues for the rotating target", CBN-07-02, 2007,
<http://www.lns.cornell.edu/public/CBN/2007/CBN07-2/CBN07-2.pdf>
6. A.Mikhailichenko, "Positron Source for ILC:A perspective", CBN-06-06, 2006,
<http://www.lns.cornell.edu/public/CBN/2006/CBN06-1/CBN06-1.pdf>
7. Preliminary Investigations of Eddy Current Effects on a Spinning Disk, W.T. Piggott, S. Walston, and D. Mayhall. UCRL-TR-224467, Sep. 8, 2006
8. Positron Source Target Update, W.T. Piggott, UCRL-PRES-227298, Jan. 16, 2007.
9. Computer Calculations of Eddy-Current Power Loss in Rotating Titanium Wheels and Rims in Localized Axial Magnetic Fields. D.J. Mayhall, W. Stein, and J. Gronberg, UCRL-TR-221440, May 17, 2006
10. A Preliminary Low-Frequency Electromagnetic Analysis of a Flux Concentrator, D.J. Mayhall, UCRL-TR-221994, June 13, 2006