

Review of element positions for FONT @ ATF2

The FONT project group
(JAI, Oxford University &
ASTeC, Daresbury)

Design of FONT at ATF2

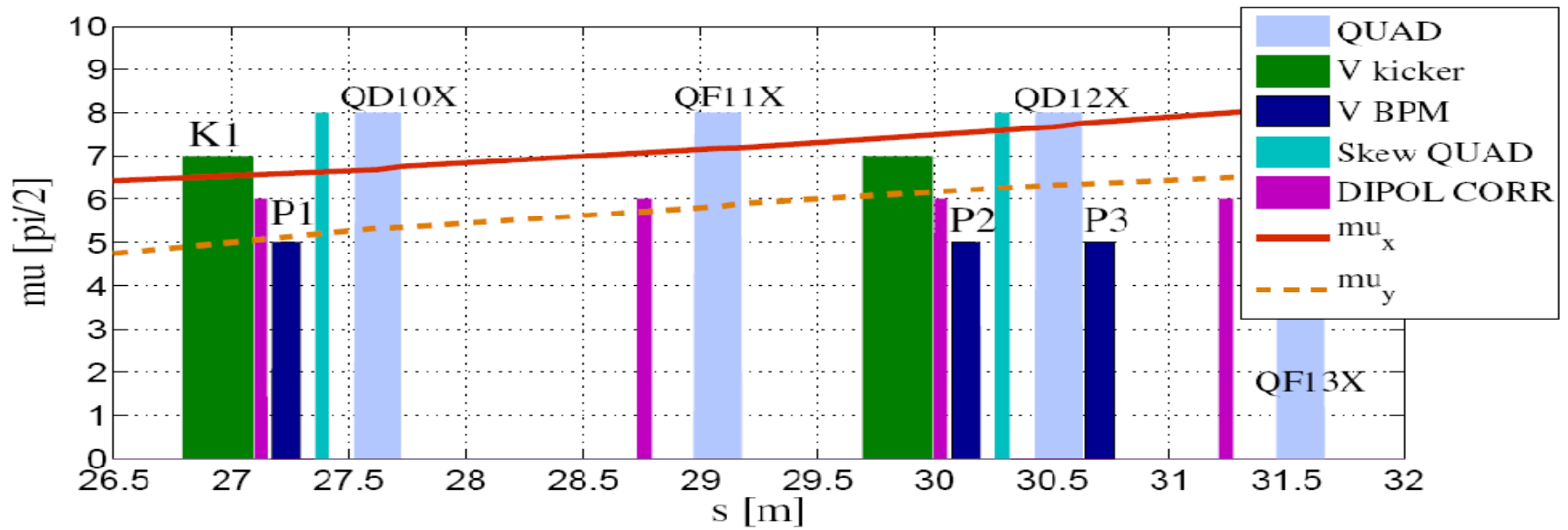
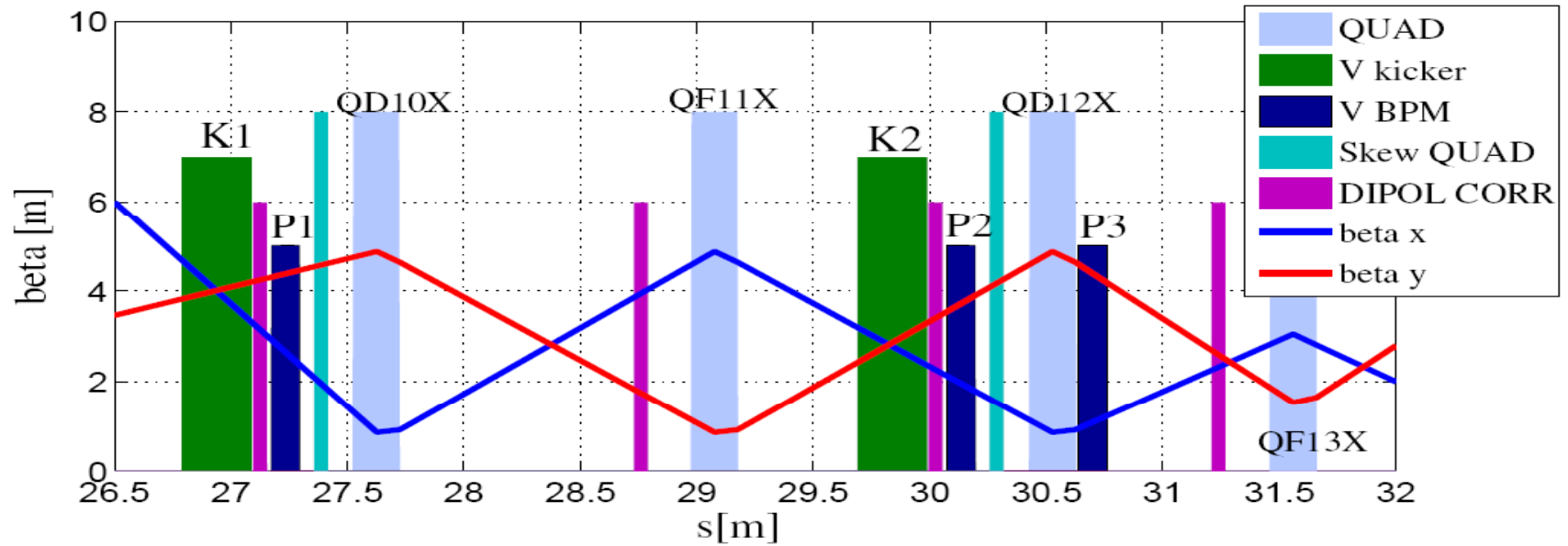

Design of FONT at ATF2

Kicker K1 & BPM P1

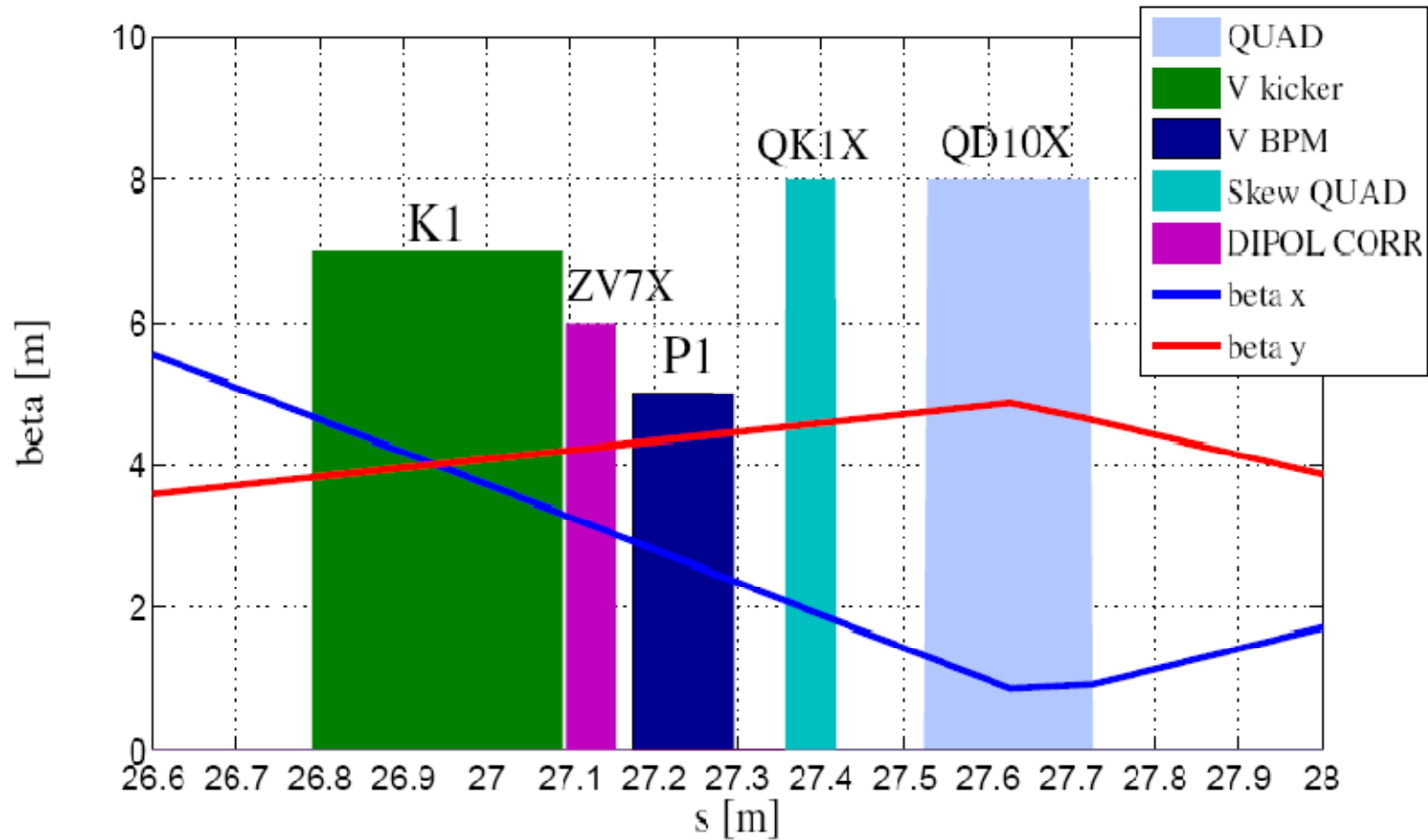

Design of FONT at ATF2

Kicker K2, BPMs P2 & P3

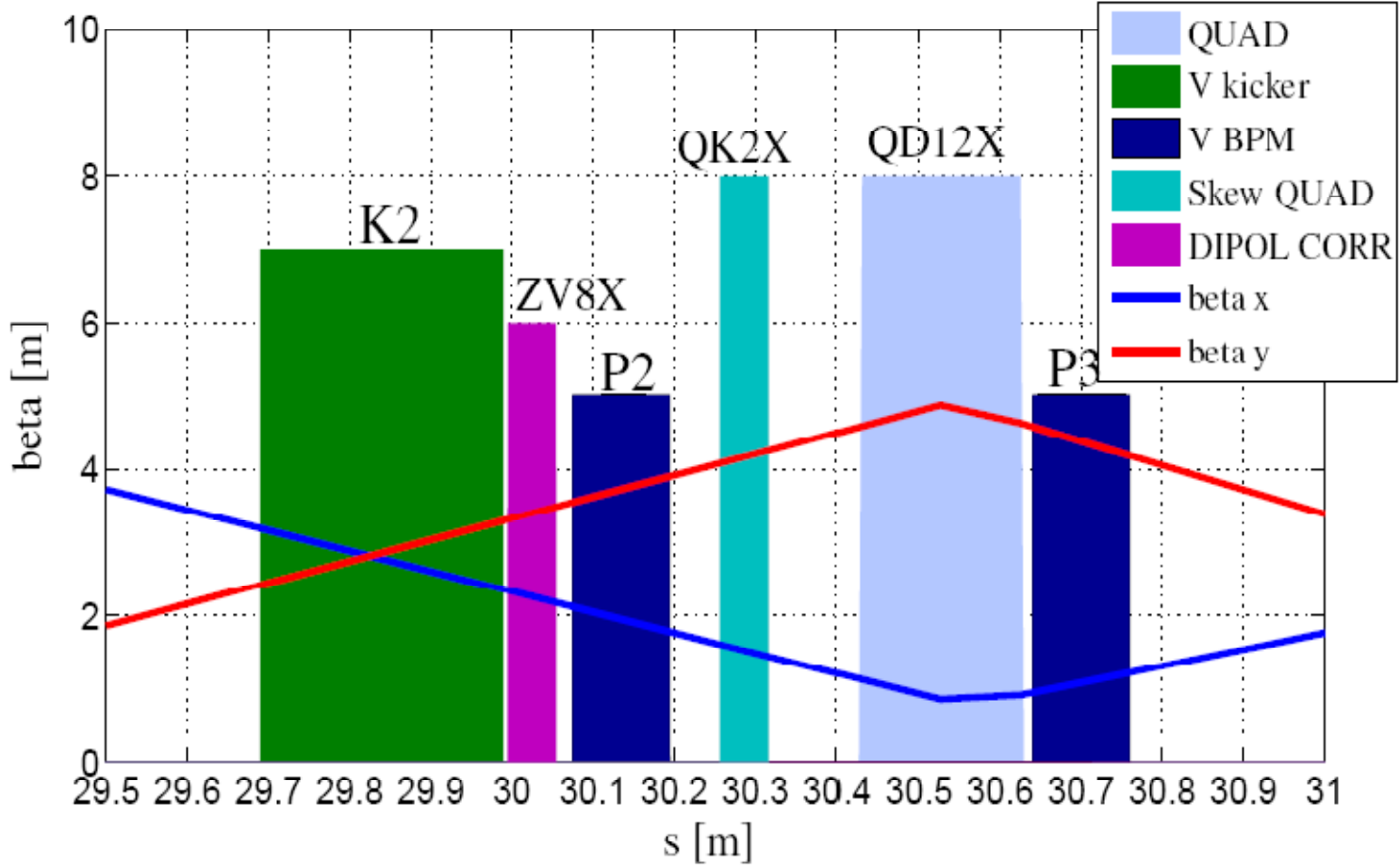

Schematic of the lattice

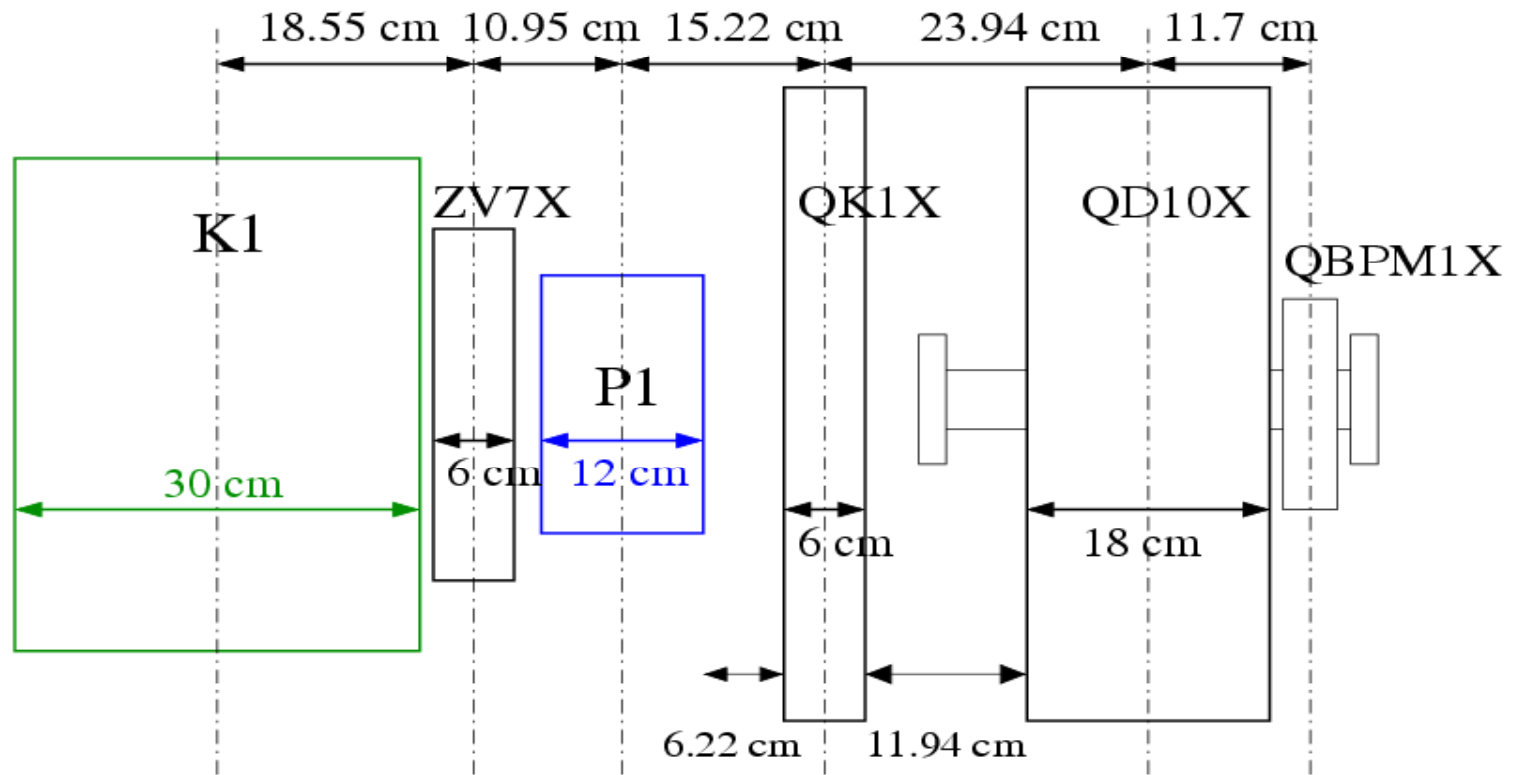

Schematic of the lattice

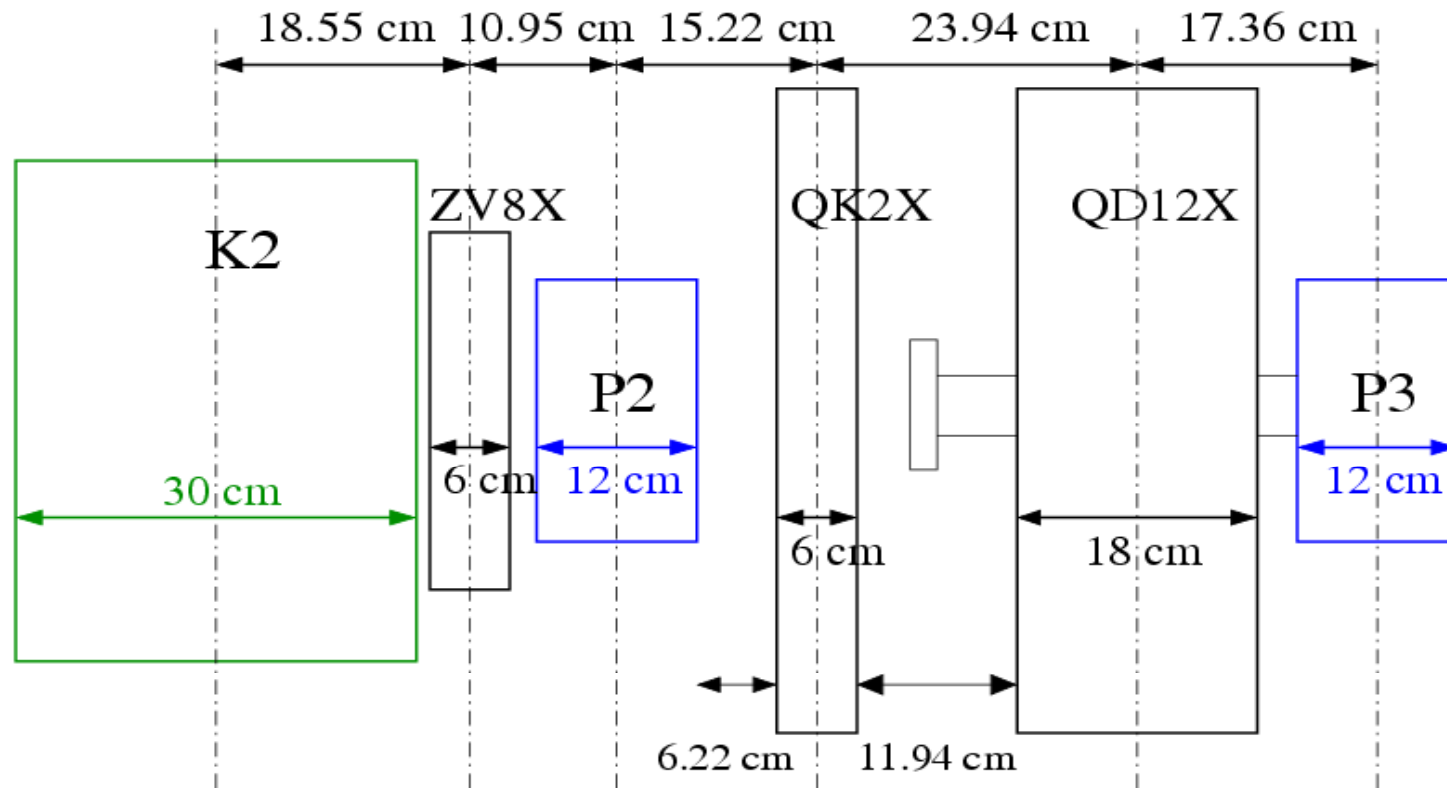

FB correction algorithms

FF and FB using the same kicker and BPM pairs. Interesting test option!

Pilot bunch algorithm: all bunches in a train are corrected using the same FB signal obtained from the first, pilot bunch

Two parallel FB systems for independent correction for angle and position

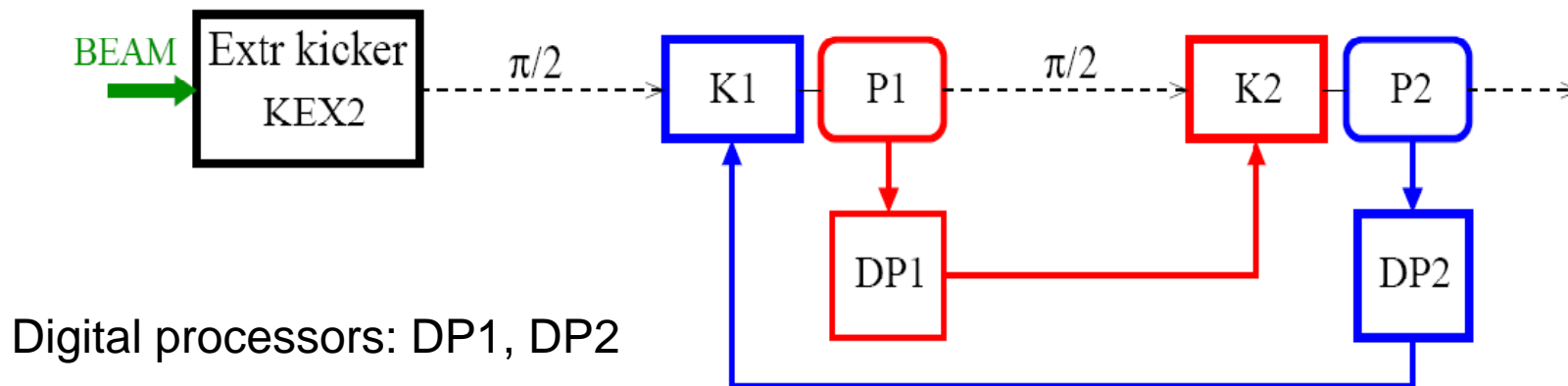

FB correction algorithms

Schematic for coupled angle and position correction

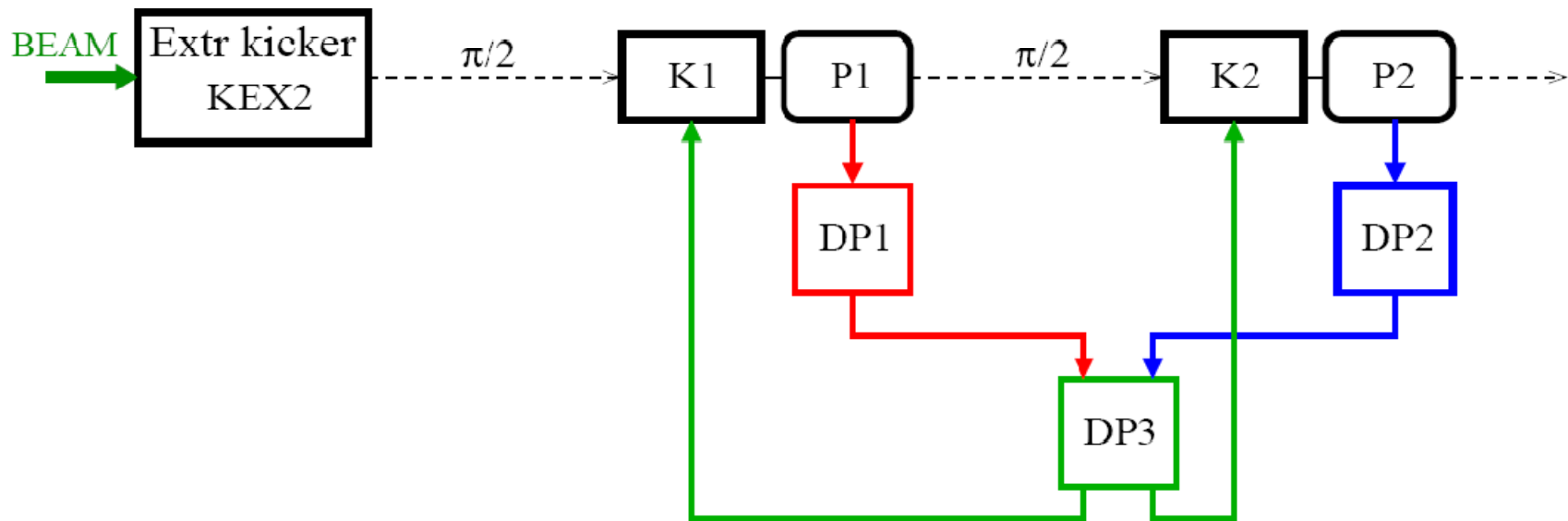

Adding different weights for simultaneous angle and position correction