

Design of ATF2 feedback/feed-forward systems

Javier Resta Lopez
(JAI, Oxford University)
for the FONT project group

LC-ABD meeting
Birmingham, 17-18th April 2008

Introduction

ATF2: Final focus test beam line facility at KEK

In principle the ATF2 optics design is identical to that for the ILC in spite of the two order of magnitude lower beam energy (Raimondi & Seryi final focus system)

Perfect bed to make experiments on beam dynamics and technologies for beam delivery systems in linear colliders

M. Woodley optics v3.8

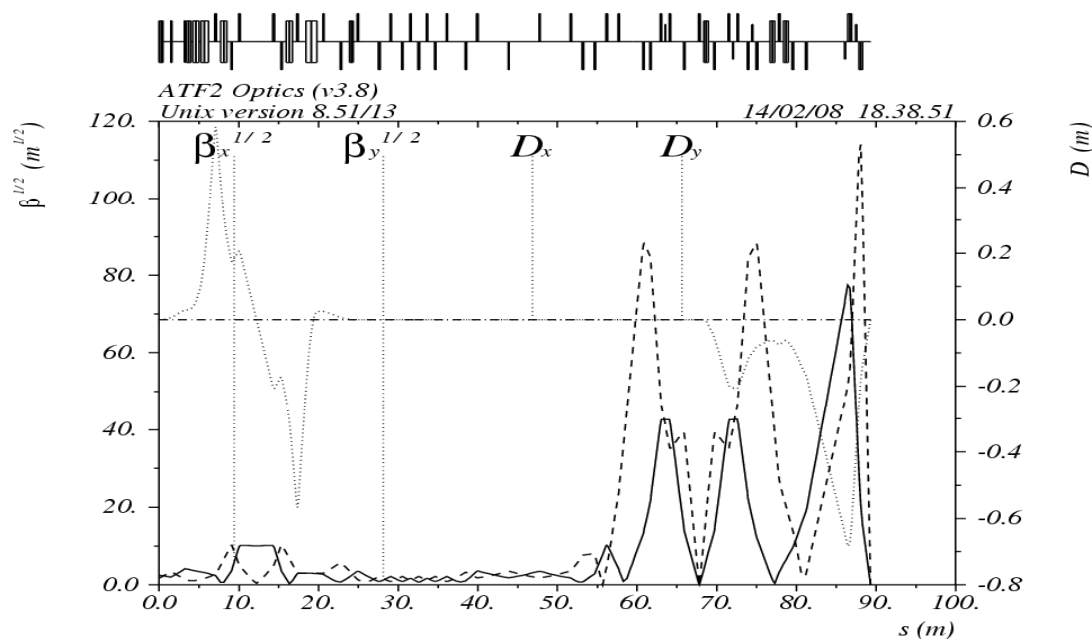

Parameter	ATF2	ILC (nominal)	
Nominal energy [GeV]	1.3	250	
Energy spread [%]	~ 0.1	~ 0.1	
$\gamma\epsilon_y^*$ [nm-rad]	30	40	
γC_x^* [nm-rad]	3000	10000	
β_y^* [mm]	0.1	0.4	
β_x^* [mm]	4.0	21	
Bunch length σ_z [mm]	8.0	0.3	
Single bunch operation:			
	Goal A	Goal B	
N_{bunch} [10^{10}]	0.5	0.5	-
Multibunch operation:			
	Goal A	Goal B	
n_{bunch}	1-20	3-20	2625
N_{bunch} [10^{10}]	0.5	0.5	2

Introduction

- The ATF2 beam line will allow us to test fast intra-train feed-back (FB) and feedforward (FF) systems for beam stability:
 - FB system in extraction line (to operate in multibunch mode)
 - FF ring to extraction line (which can operate in multibunch or single bunch mode) → to model the ILC Turnaround trajectory FF system [A. Kalinin, P. N. Burrows, "Turnaround feed-forward correction at the ILC", EUROTev-REPORT-2007-050, June 2007]
- **FONT**: Feedback systems on Nanosecond Timescales.

Summary of the results of latency time of the previous FONT tests [G. Christian et al., LC-ABD meeting 24-09-07: http://www.hep.man.ac.uk/lc-abd/LC-ABD_Sept07_talks]

Test	Facility	Train length [ns]	Bunch spacing [ns]	Latency [ns]
FONT1	NLCTA (SLAC)	170	0.087	67
FONT2	NLCTA (SLAC)	170	0.087	54
FONT3	ATF (KEK)	56	2.8	23
FONT4	ATF (KEK)	420	140	132

FONT5 is being designed to perform both FB and FF tests at ATF2!

Introduction: FONT elements

Goal: adaptation of upstream FONT system for ATF2

- FF+ FB systems in the ATF2 extraction line (EXT):
 - A pair of kickers (K1 & K2) for the correction of (y, y')
 - The kickers are common for FF and FB
 - Each kicker has an adjacent pickup (P1 & P2) that is used for response matrix construction
 - Downstream witness pickup P3 (also available for FB system test)
 - Pickups (BPMs) in the ATF2 EXT are adjacent to quadrupoles

Location constraints:

- Relatively high beta y (higher resolution tolerances)
- $\pi/2$ phase advance kicker-BPM
- Low time flight to reduce latency (the total latency goal ~ 150 ns)

Javier Resta Lopez

17th April 2008

Position taken at the center of the element

Element	s [m]
KICKER	
K1 (for y correction)	26.94
K2 (for y' correction)	29.84
BPM	
P1	27.23
P2	30.13
P3	33.00

kicker length = 30 cm

BPM length = 12 cm

Layout of FONT at ATF2

M. Woodley's lattice v3.8

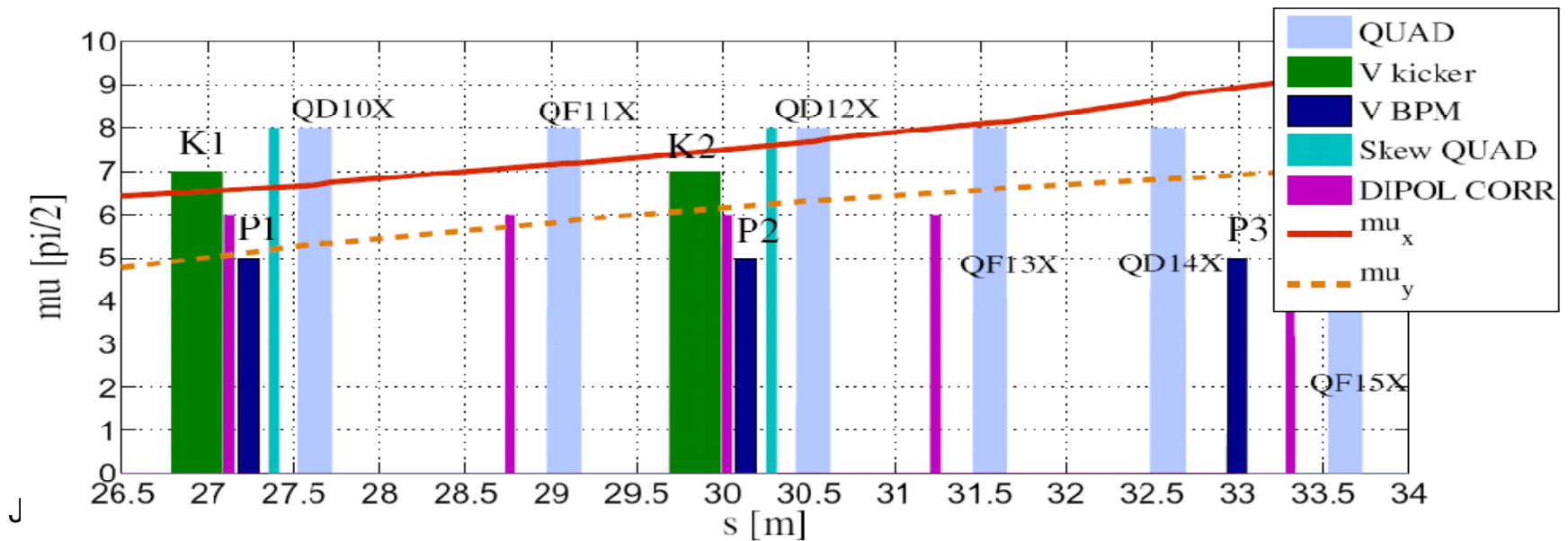
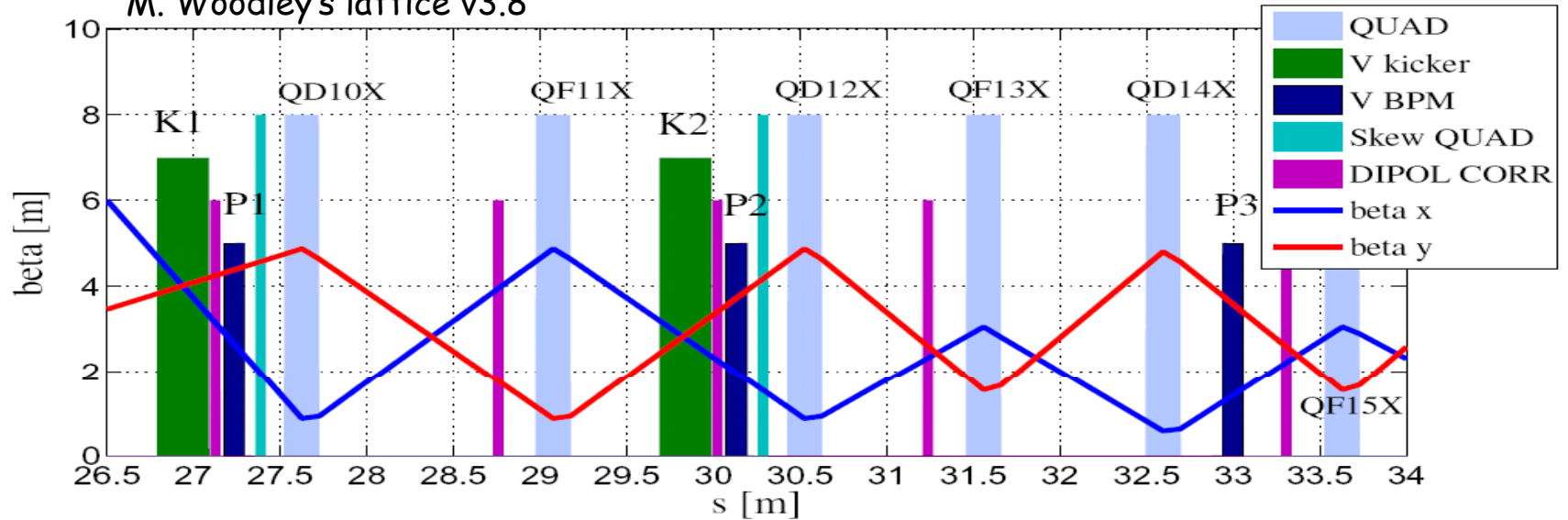

Kicker parameters

(approximate estimate)

Kick angle of fast stripline kicker:

$$\Delta\theta = 2g \frac{eV}{E} \frac{L}{d}$$

“g” is the stripline coverage factor or geometry factor:

$$g = \tanh\left(\frac{\pi\omega}{2d}\right) \leq 1 \quad (\text{determined by the shape of the electrode})$$

V : peak voltage

E : beam energy (1.3 GeV)

R : impedance (50 Ω)

L : kicker length (30 cm)

$d=2a$: kicker gap width (~30 mm)

a : half gap

Constraint: $a < 20$ mm (beam line aperture)

For example: $a=15$ mm; kick of 10 μrad \bullet ⌚ 0.4 kV

$a=15$ mm; kick of 100 μrad \bullet ⌚ 3.0 kV

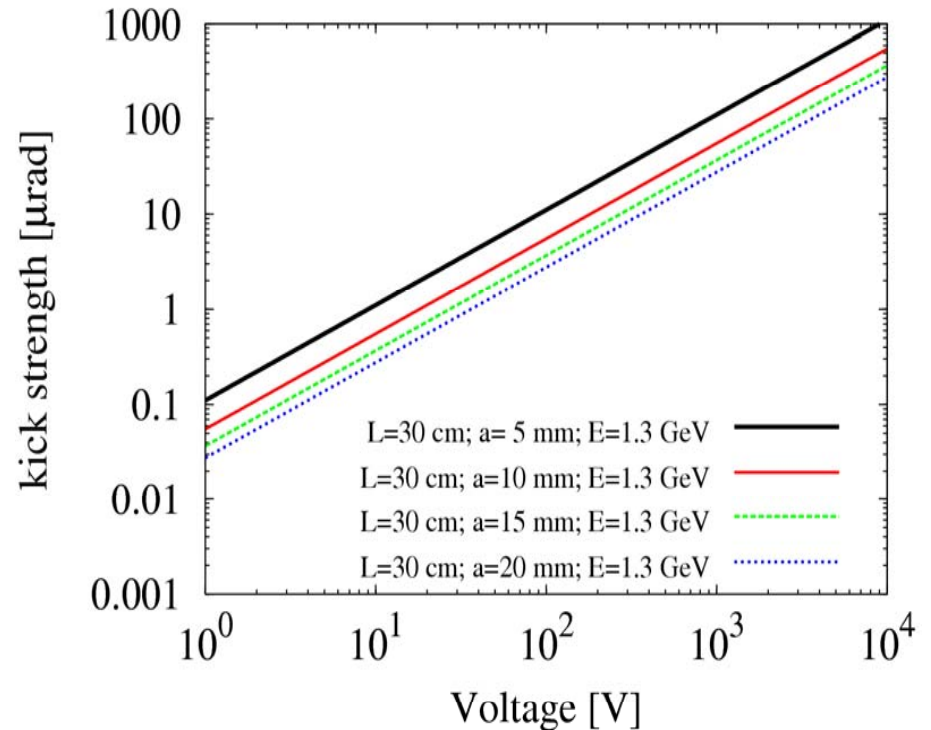

Kicker mechanical design

SLC Scavenger Post stripline kicker
From Simon Jolly's thesis, 2003

2 striplines connected electrically by a pair of pins each

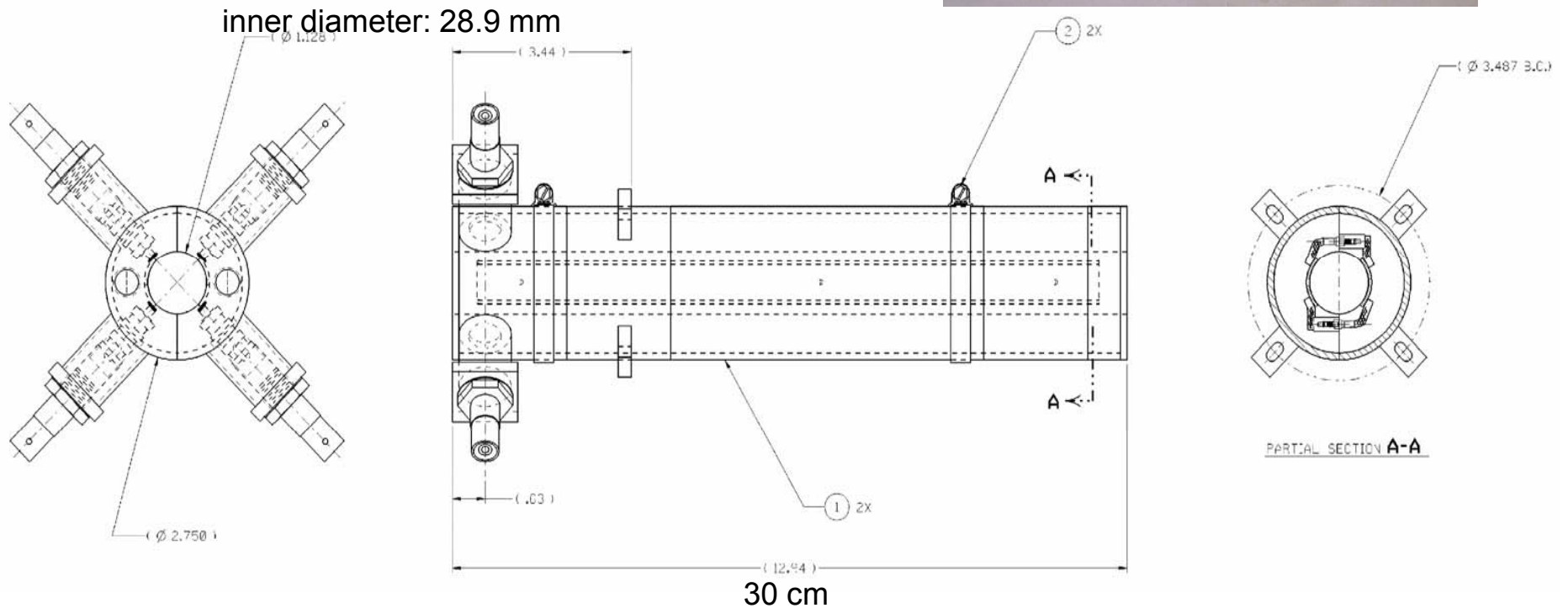
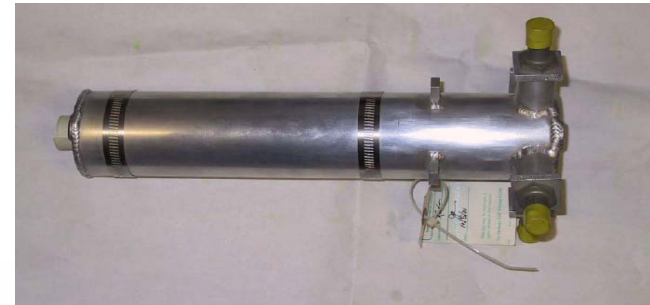

Rise and fall times of the pulse : 2 – 3 ns

BPM mechanical design

Spare linac BPM from SLC
 3 BPMs available for FONT
 Courtesy of Steve Smith

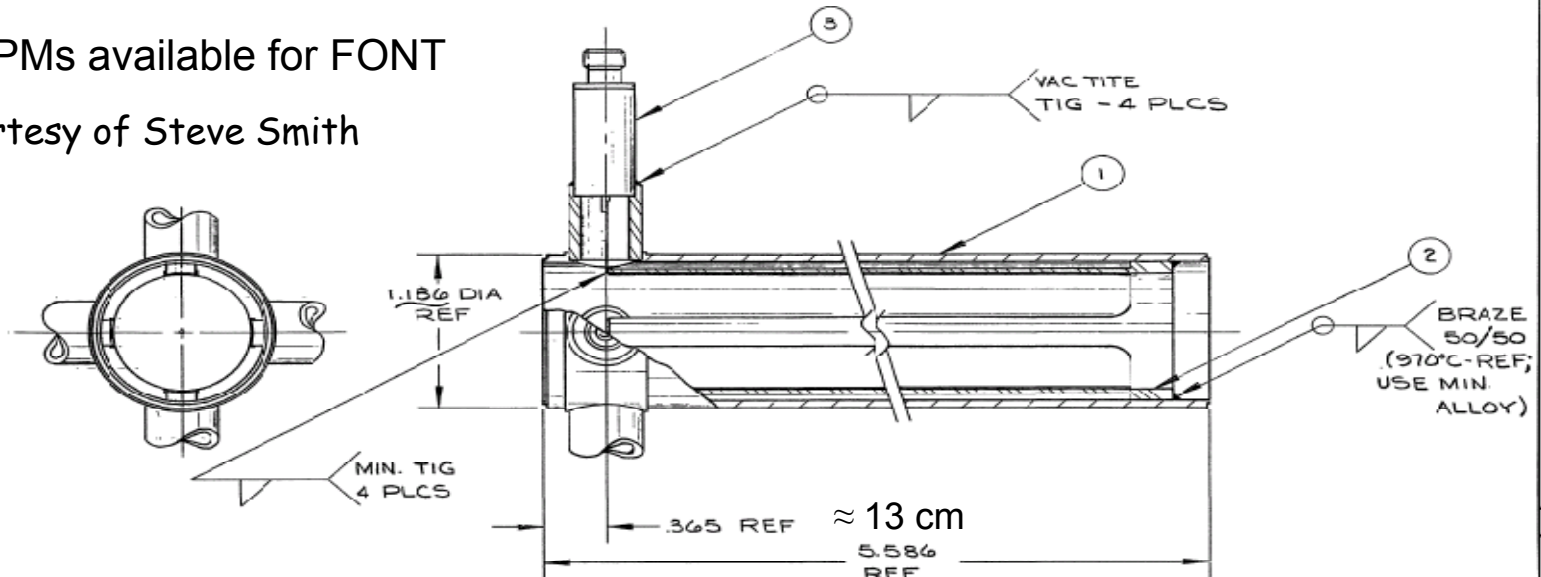

- NOT TO SCALE - DO NOT SCALE DWG.
 NOTE: ASSEMBLY PROCEDURE
 1. BRAZE ITEM-2- (STRIP ELECTRODE) INTO ITEM-1- (VAC TUBE) USING ALIGNMENT FIXTURE (3 PIECES ON MP-906-205-88) 2. WELD ITEM-3- IN PLACE (4 PLCS)
 3. WELD FEEDTHRU STRIP TO STRIP ELECTRODE (4 PLCS)

ITEM	PART NUMBER	DESCRIPTION	QTY
3	SA-906-205-83	FEED-THRU MODIFICATION	4
2	PF-906-205-87	STRIP ELECTRODE	1
1	SA-906-205-86	VAC TUBE	1

To operate in microm level stability →
 BPM resolution ~ 1μm

STANFORD LINEAR ACCELERATOR CENTER U. S. DEPARTMENT OF ENERGY STANFORD UNIVERSITY STANFORD CALIFORNIA		SLBPM0 (1.186" DIA) ASSEMBLY	
PROPRIETARY DATA OF STANFORD UNIVERSITY AND/OR U.S. DEPARTMENT OF ENERGY. RECIPIENT SHALL NOT PUBLISH THE INFORMATION WITHIN UNLESS GRANTED SPECIFIC PERMISSION OF STANFORD UNIVERSITY.		SA 906-205-84 R0 C	
ENGR. BILL BRUNK DTS. GEO. AIKEN CHKD. [Signature]	DATE 11-2-81 DATE 11 24 81	APPROVALS [Signature] 11 24 81	

SA 906-205-84 R0 C

HFRD

Simulation set up for orbit correction

- Using the tracking code Placet-octave (developed at CERN)
- Only considered the y, y' correction
- Added a total of 50 BPM along the ATF2 line in order to study the jitter propagation and the correction effect from the correction region to the IP
- Two kickers (K1 & K2) for vertical position (Y) and angle (θ) correction
- Two pickups (P1 & P2) for transfer matrix reconstruction
- Normal random distribution of 100 initial vertical jitter positions with a width of $\pm 40\% \sigma_y$ (rms beam size at the entrance of the extraction line)
- Assuming a BPM rms noise of $1 \mu\text{m}$
- Assuming a kicker strength error of $< 0.5\%$
- Introducing ground motion (GM) misalignment (ATL model K)

Simulation set up

Impact of the GM in the vertical element position

For the simulation we have used a GM package which is implemented in the tracking code Placet and is based on the models provided by A. Seryi
[A. Seryi, <http://www.slac.stanford.edu/~seryi/gm/model>]

Vertical misalignment of the elements in the ATF2 beam line applying the GM model K (KEK site) at different time moments:

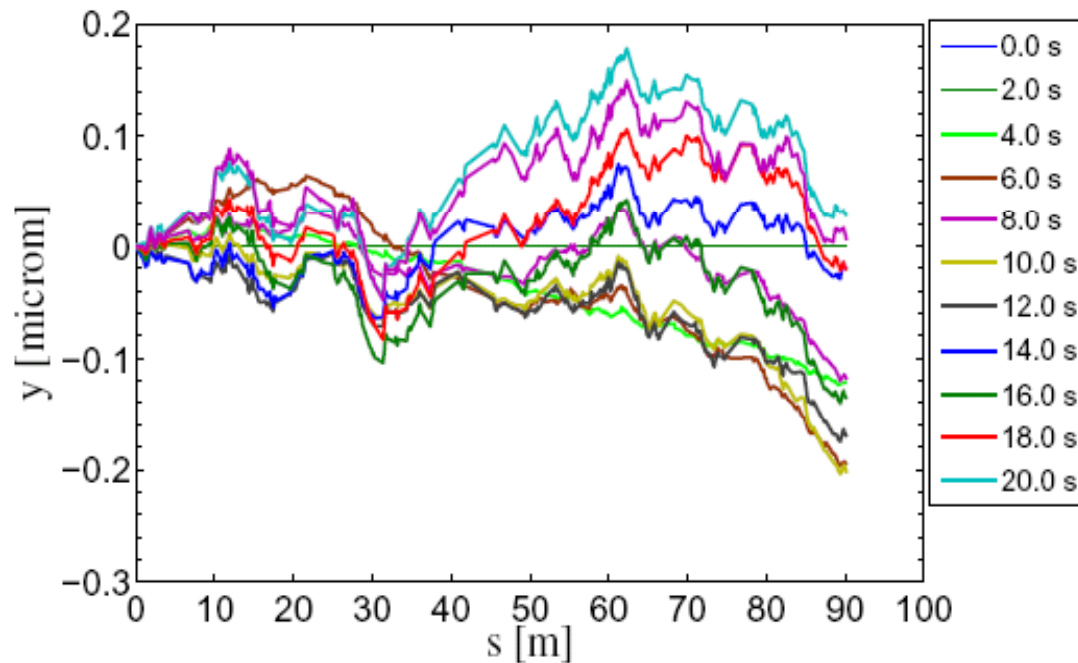

Estimate of the BPM resolution

- Three BPM method:

In a dispersion-free section, the beam offset y_3 at an arbitrary line position s_3 can be predicted from the offsets y_1 and y_2 at two other positions s_1 and s_2 respectively

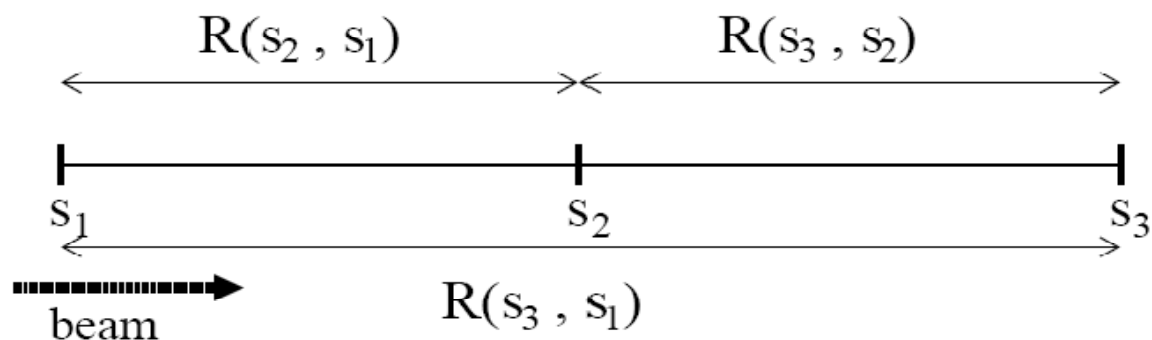

$$y_3 = \left(R_{33}(s_3, s_1) - \frac{R_{34}(s_3, s_1)R_{33}(s_2, s_1)}{R_{34}(s_2, s_1)} \right) y_1 + \frac{R_{34}(s_3, s_1)}{R_{34}(s_2, s_1)} y_2$$

The transfer matrix elements can be measured using the three BPMs

Transfer matrix reconstruction

- The transfer matrix between two positions in a line can be constructed using two BPMs. Considering only linear optics:

$$\begin{pmatrix} y \\ y' \end{pmatrix}_2 = \begin{pmatrix} R_{33} & R_{34} \\ R_{43} & R_{44} \end{pmatrix} \begin{pmatrix} y \\ y' \end{pmatrix}_1$$

- Let the point 1 (BPM P1) be adjacent to a corrector or kicker (K1)

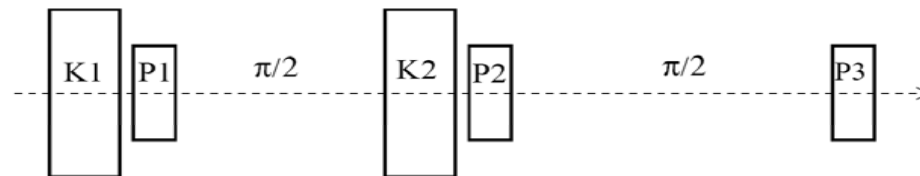

- Then two measurements are required to determine R_{34} :
 - with $y_2(\text{measure1})$ at P2 obtained with the nominal trajectory and $(y, y')_1$ at P1
 - with $y_2(\text{measure2})$ at P2 obtained with the nominal trajectory and $(y, y' + \Delta\theta)_1$ at P1, where $\Delta\theta$ is an arbitrary kick angle introduced by the corrector K1
- Then $R_{34} = \{y_2(\text{measure 2}) - y_2(\text{measure 1})\} / \Delta\theta_1$

BPM resolution for FONT at ATF2

- From simulation results using the tracking code Placet-octave

$$\sigma_{\text{reso},i} = \sqrt{\langle (y_{i,\text{measured}} - y_{i,\text{predicted}})^2 \rangle}$$

BPM P_i	$\sigma_{\text{reso},i}$
P1	1.4094 μm
P2	2.4002 μm
P3	1.5542 μm

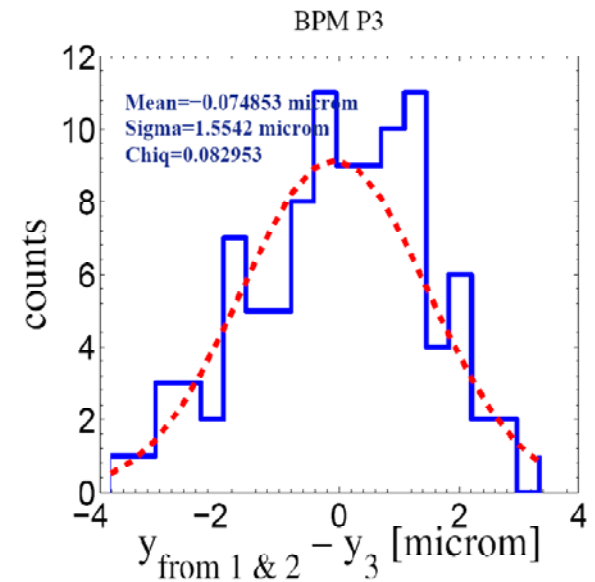
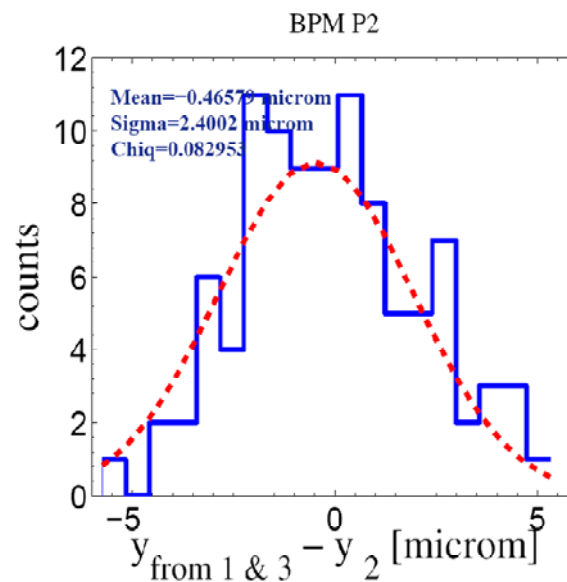
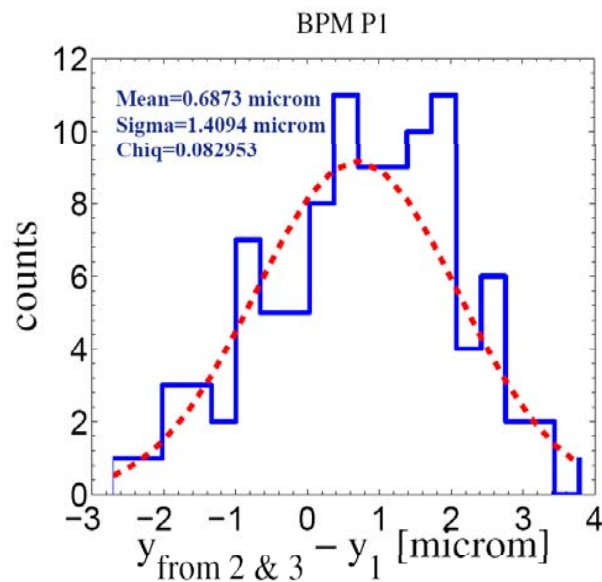

Basic review. Feed-forward correction

Kicker strength calculation

- Two BPMs (BPM1 & BPM2) in order to construct the transfer matrix
- Two kickers (K1 & K2) for vertical position (Y) and angle (Θ) correction
- Let $\begin{pmatrix} y_{K1} \\ \theta_{K1} \end{pmatrix}$ be the position and angle at K1 position before applying the correction

$$\begin{pmatrix} Y \\ \Theta \end{pmatrix} = \overbrace{\begin{pmatrix} 0 \\ \Delta \theta_2 \end{pmatrix}}^{\text{Kicker 2}}_{K2} + \begin{pmatrix} R_{33} & R_{34} \\ R_{43} & R_{44} \end{pmatrix} \left[\overbrace{\begin{pmatrix} 0 \\ \Delta \theta_1 \end{pmatrix}}^{\text{Kicker 1}}_{K1} + \begin{pmatrix} y_1 \\ \theta_1 \end{pmatrix} \right]$$

Kicks for correction $\begin{pmatrix} Y \\ \Theta \end{pmatrix} = \begin{pmatrix} 0 \\ 0 \end{pmatrix} \longrightarrow \begin{pmatrix} \Delta \theta_1 \\ \Delta \theta_2 \end{pmatrix} = \begin{pmatrix} -\frac{R_{33}}{R_{34}} & 1 \\ \frac{R_{44}R_{33} - R_{34}}{R_{34}} & 0 \end{pmatrix} \begin{pmatrix} y_1 \\ \theta_1 \end{pmatrix}$

Let δy and $\delta \theta$ be the correction residue, which propagates to the IP: $\begin{pmatrix} \delta y_{IP} \\ \delta \theta_{IP} \end{pmatrix} = \mathbf{R}_{IP} \begin{pmatrix} \delta y \\ \delta \theta \end{pmatrix}$

Tolerable residual error: $\delta y_{IP} \leq 0.1\sigma_y^* \approx 4 \text{ nm}$

Results of vertical position correction

Residual jitter propagation

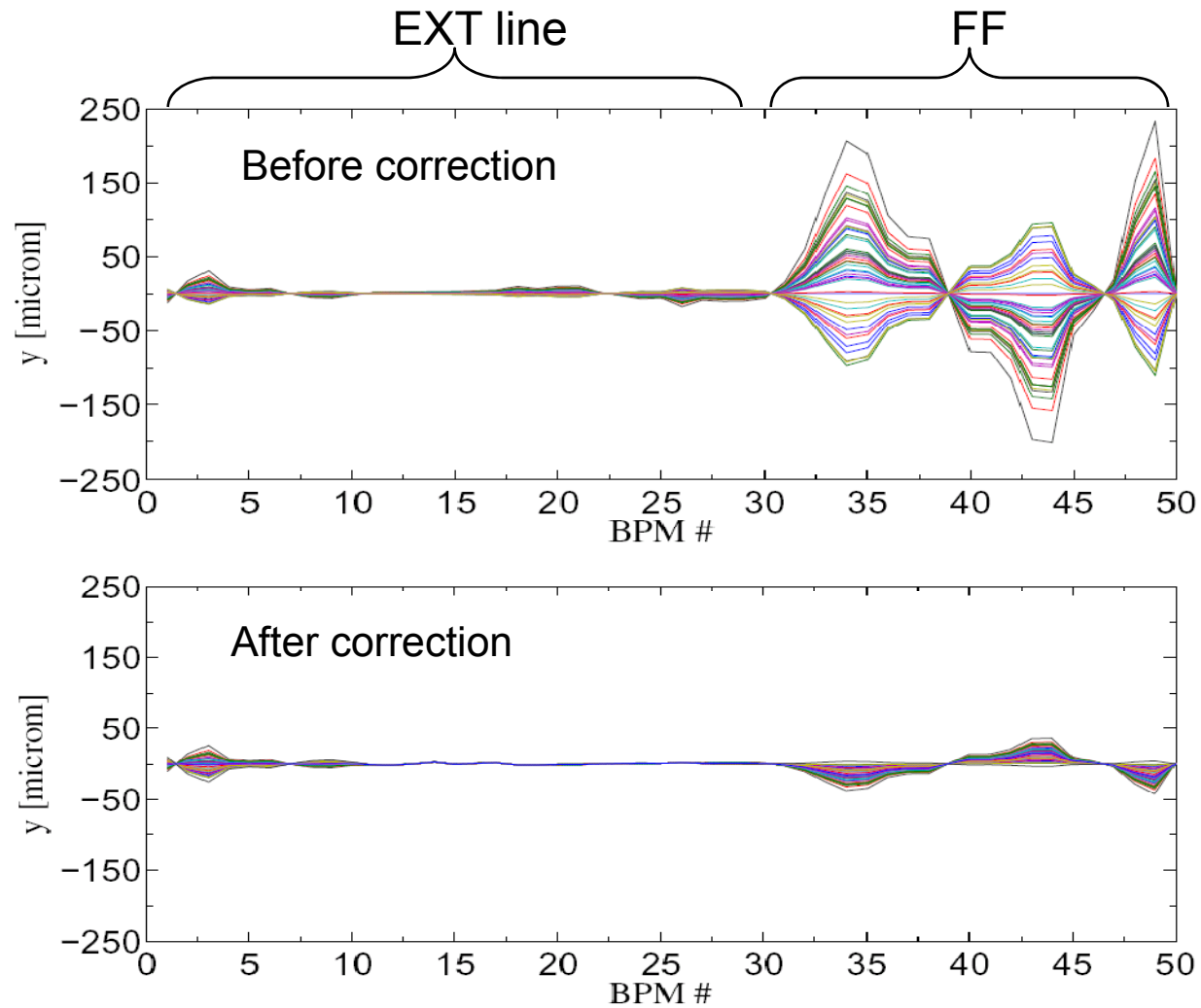

FONT BPMs:
BPM 9 (P1)
BPM 14 (P2)
BPM 19 (P3)

Results of vertical position correction

Residual jitter propagation

Zoom of the EXT line:

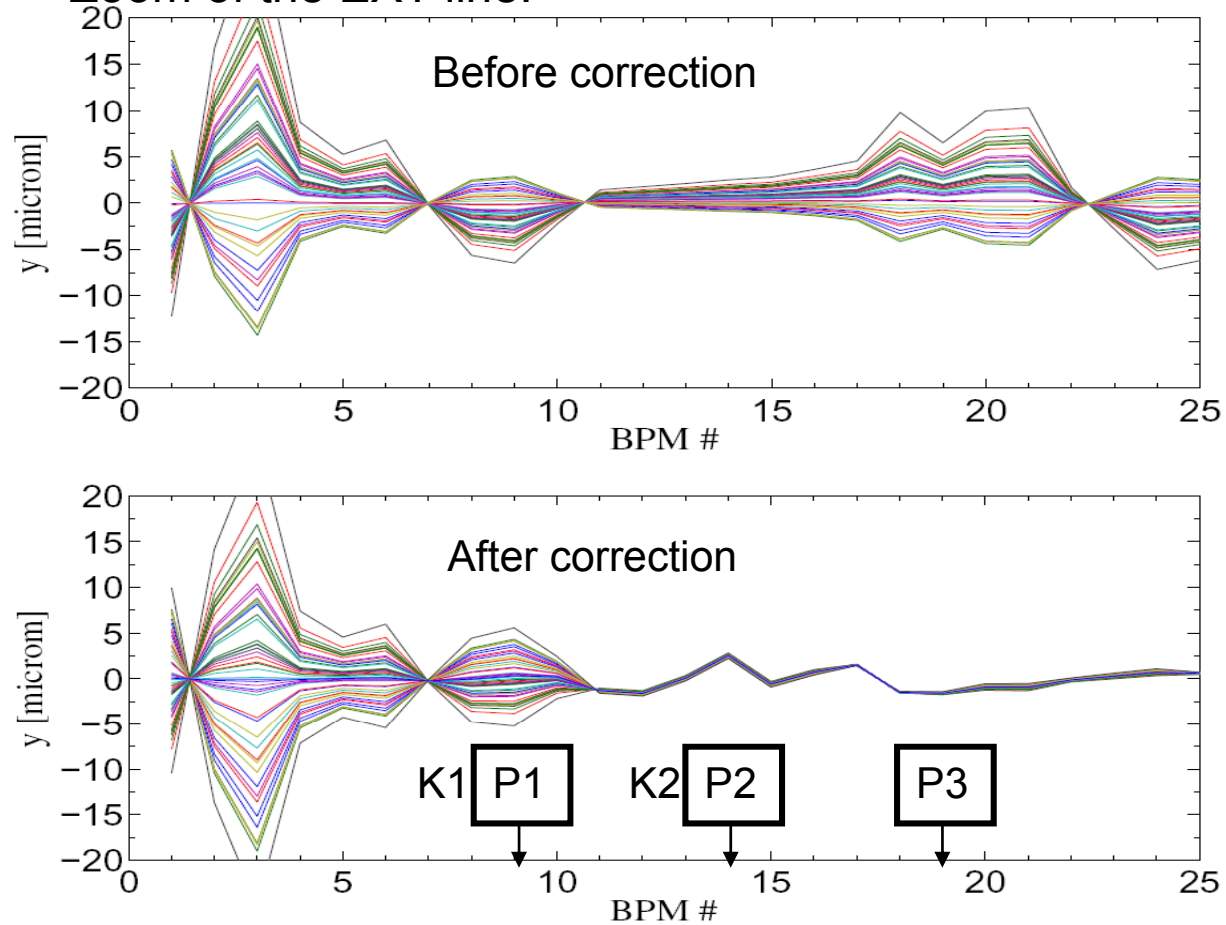

Jitter distribution at the IP

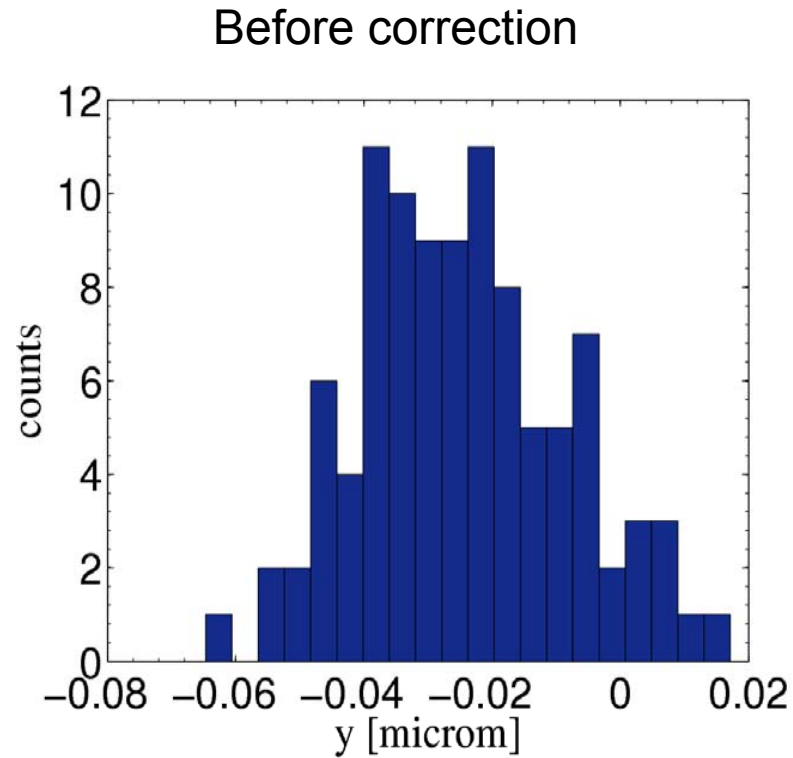

Mean = $-0.0267 \mu\text{m}$
Sigma = $0.0169 \mu\text{m}$

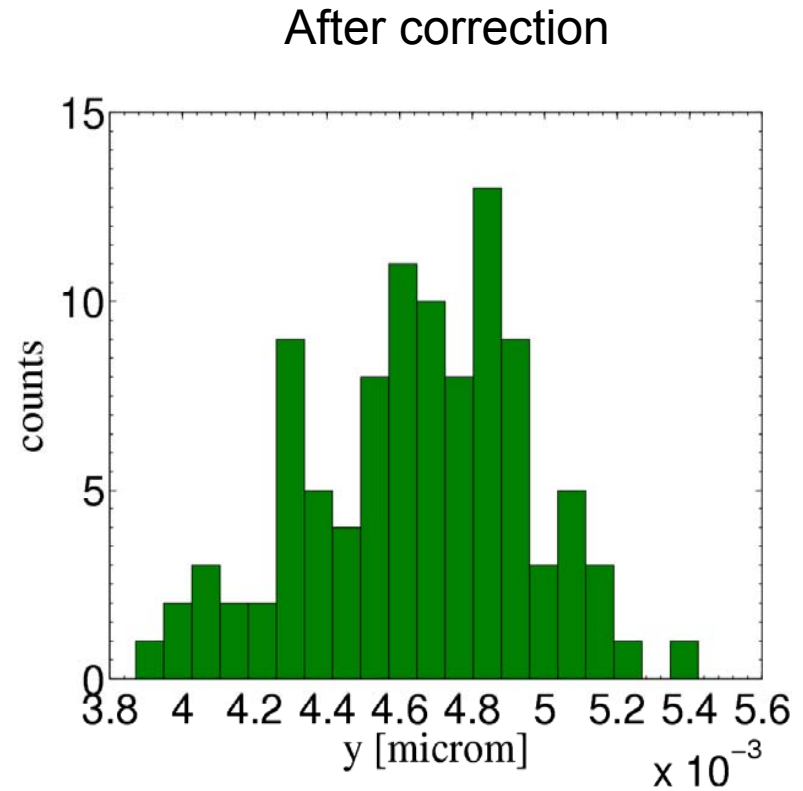

Mean = $0.00463 \mu\text{m}$
Sigma = $0.000312 \mu\text{m}$

Sensitivity to BPM resolution

Considering an initial random jitter distribution with a rms error of 40 % of the initial beam size

Each point is the average over 50 seeds

The error bars correspond to the standard deviation

Residual jitter at IP
vs BPM resolution:

If we consider that the mean value of the residual jitter at the IP $< 0.1 \sigma_y^*$ then BPM resolution $< 1 \mu\text{m}$

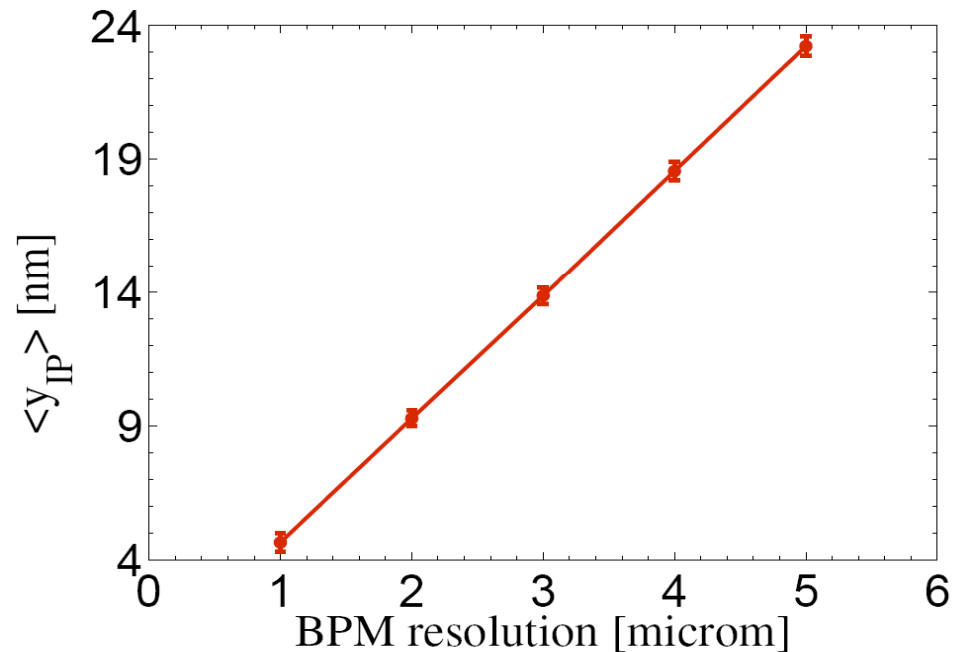

Sensitivity to kicker strength error

Considering an initial random jitter distribution with a rms error of 40 % of the initial beam size

Each point is the average over 50 seeds

The error bars correspond to the standard deviation

Residual jitter at IP
vs kicker strength error:

In this case we obtain that the mean value of the residual jitter is practically constant, and the standard deviation increases as the kick strength error.

Tolerable kick error < 10 %
of the kick angle

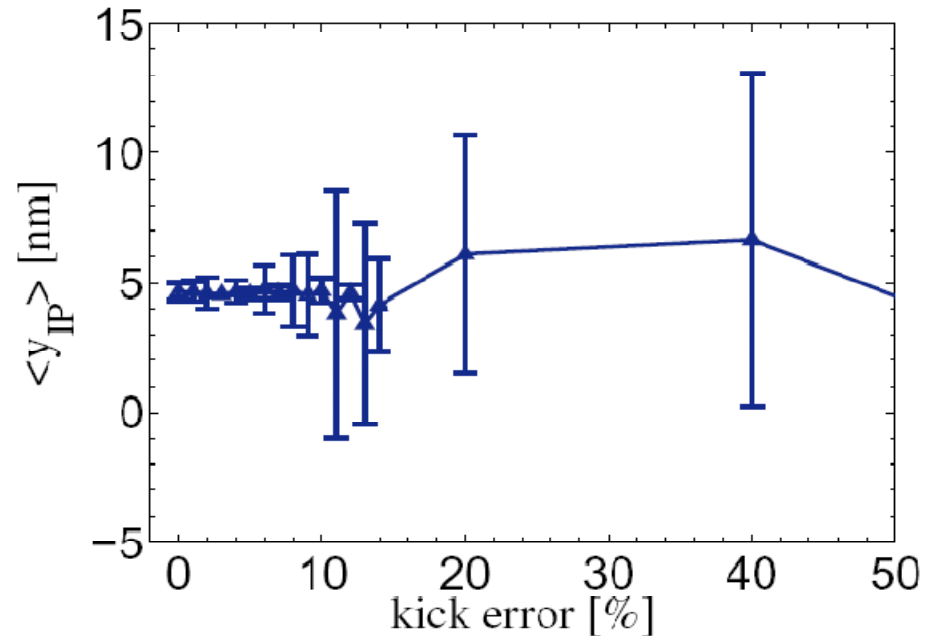

FB correction algorithms

FF and FB using the same kicker and BPM pairs. Interesting test option!

Pilot bunch algorithm: all bunches in a train are corrected using the same FB signal obtained from the first, pilot bunch

Two parallel FB systems for independent correction for angle and position

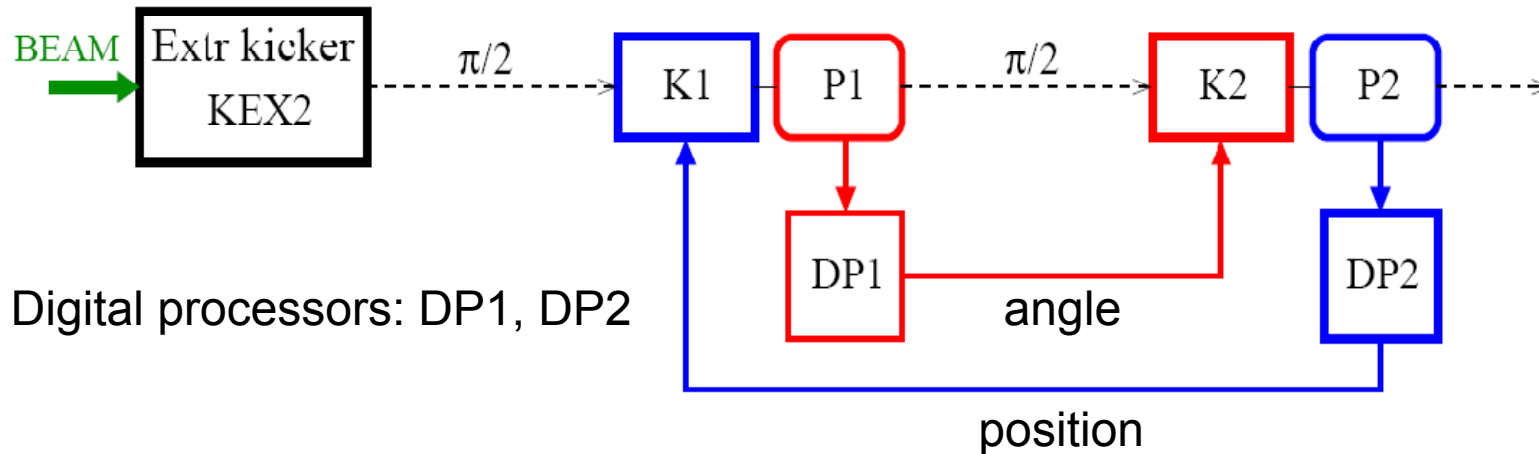

Time of flight P2-K1=10.65 ns
Time of flight P1-K2= 8.68 ns

FB correction algorithms

Schematic for coupled angle and position correction

[More details: A. Kalinin, "A Vision of the ATF2 Feedback and Feed-Forward Systems", FONT internal note, February 2008]

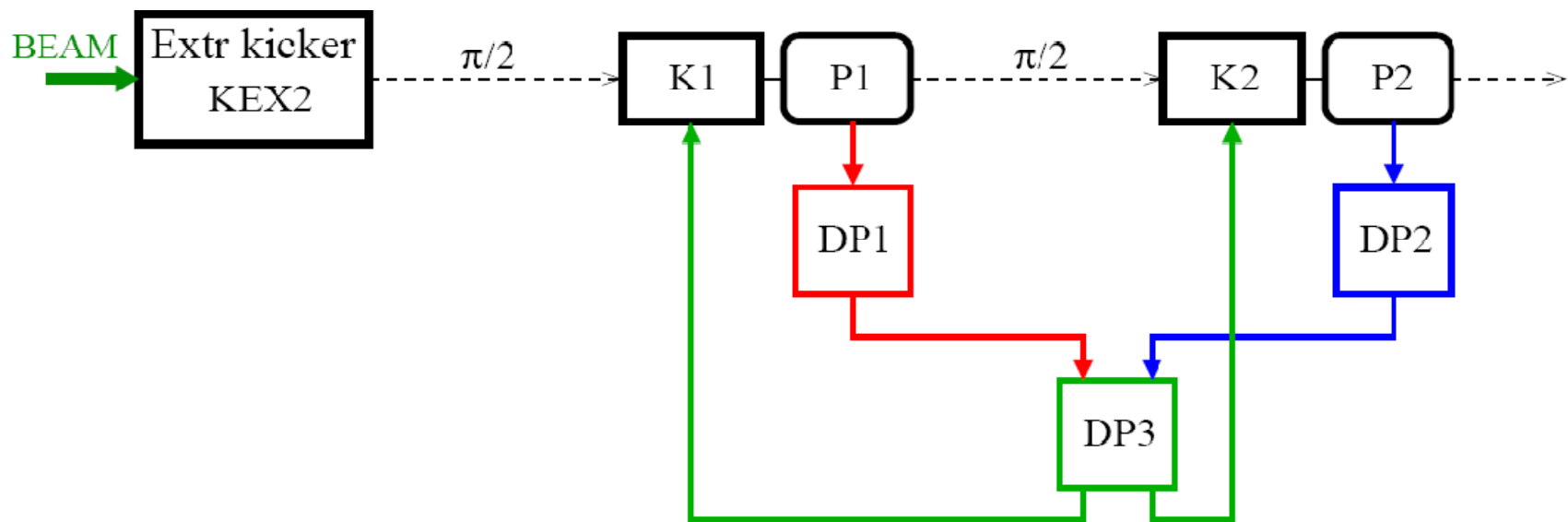

This option could be a good solution to reduce correction errors coming from the y-y' coupling

Adding different weights for simultaneous angle and position correction

FB correction algorithms

A third pickup P3 allocated downstream of P2, at $\pi/2$ phase advance, as witness BPM

In addition P3 also allow us the possibility to implement a 'classical' FB test

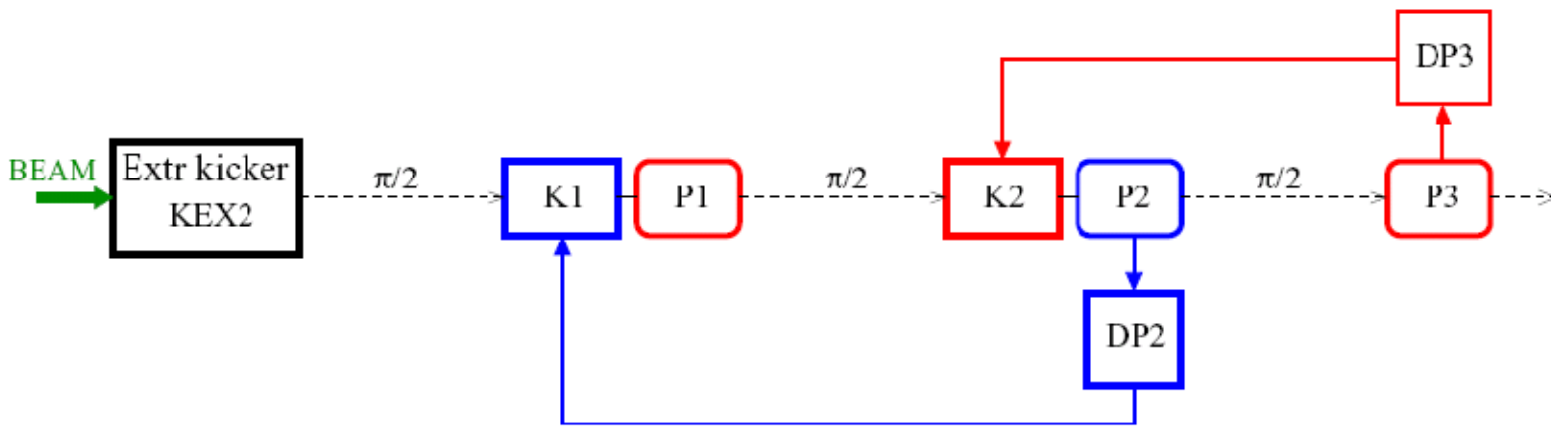

Time of flight P2-K1 = 10.65 ns

Time of flight P3-K2=10.53 ns

Summary and ongoing studies

- We have presented the layout of an intra-train feed-forward/feedback system to be placed in the extraction line of ATF2 (in the context of the FONT study)
 - Optimum BPM and kicker positions
 - Study of the necessary BPM and kicker parameters to show the feasibility of bunch-to-bunch fast jitter correction (FB system latency budget ~140 ns)
- The necessary hardware is currently being developed and tested. The FONT FB hardware can be carried over to FF.
- A Placet-octave based model of the FONT system in the ATF2 beam line has been set up. This model allows us to perform beam dynamics tracking simulations with bunch-to-bunch jitter correction, including element misalignments and GM.
- Here we have shown results of simulations of jitter correction for single bunch mode
- Simulations for multibunch mode (20- bunch train) are in progress
- Study of different FB system algorithms, which have to be tested by means of simulation studies.

Design of FONT at ATF2

Kicker K1 & BPM P1

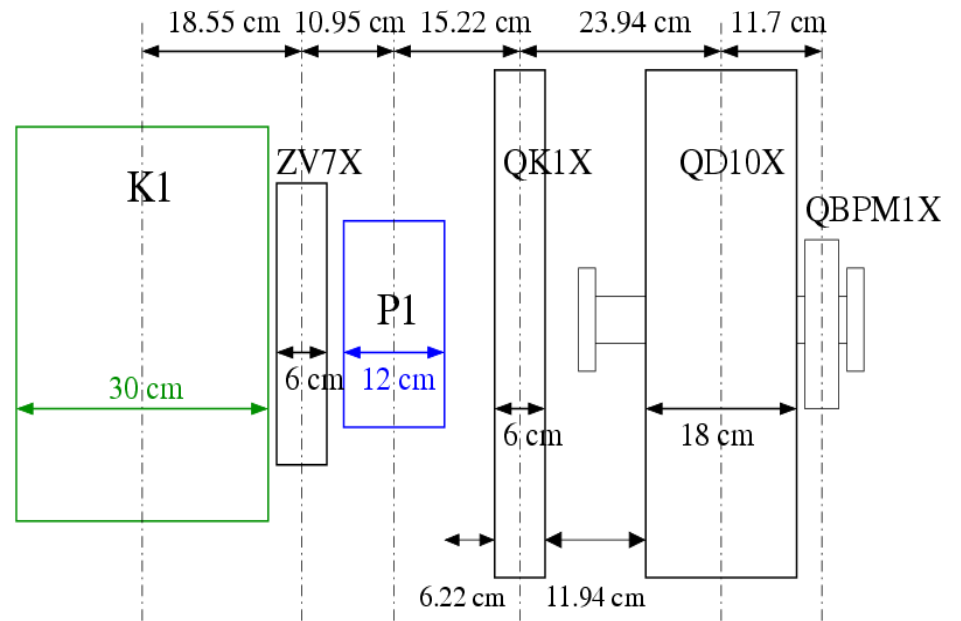
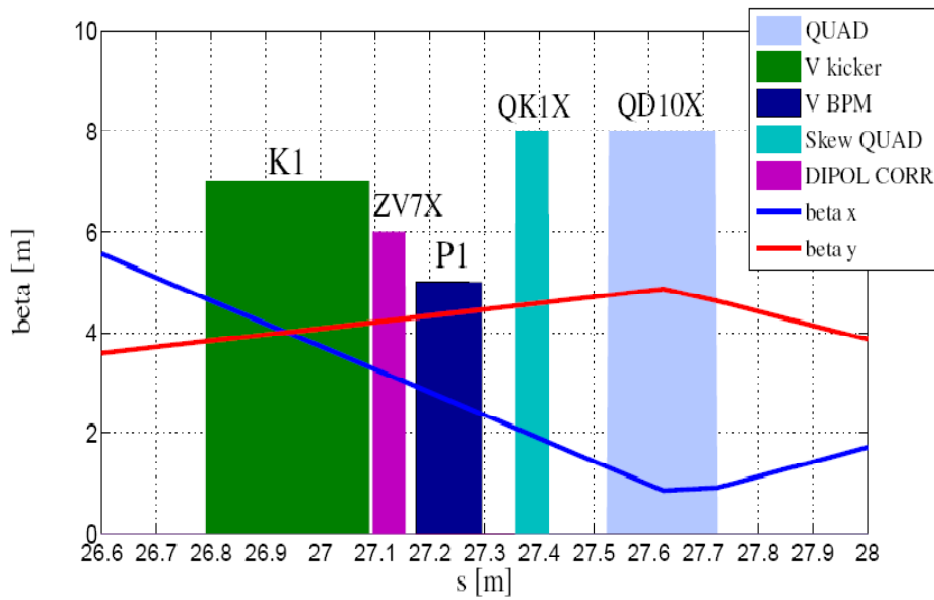

scale: 1/8 inches (drawing) = 2 cm (beamline)

Warning: Flanges not considered !

Design of FONT at ATF2

Kicker K2, BPMs P2

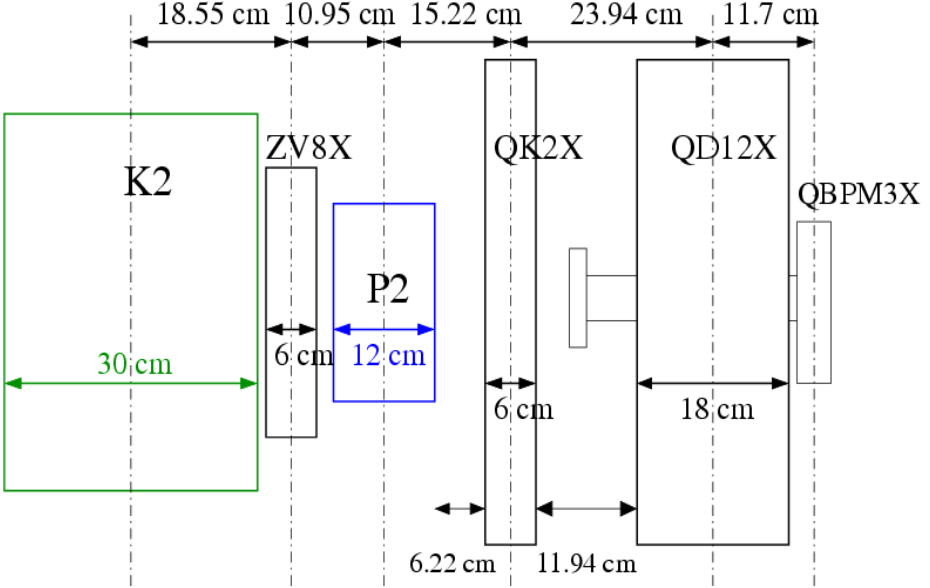
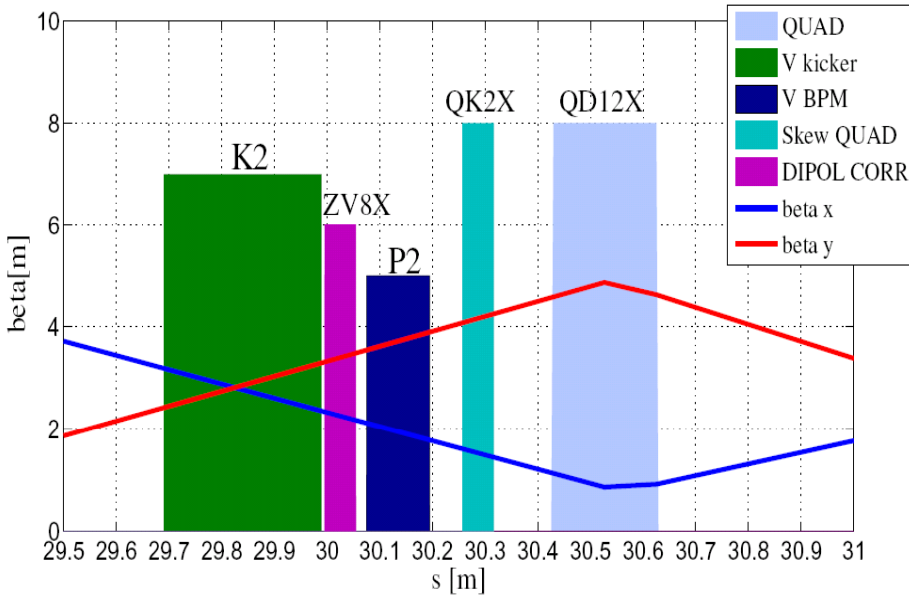

scale: 1/8 inches (drawing) = 2 cm (beamline)

Warning: Flanges not considered !

Phase advance between kickers

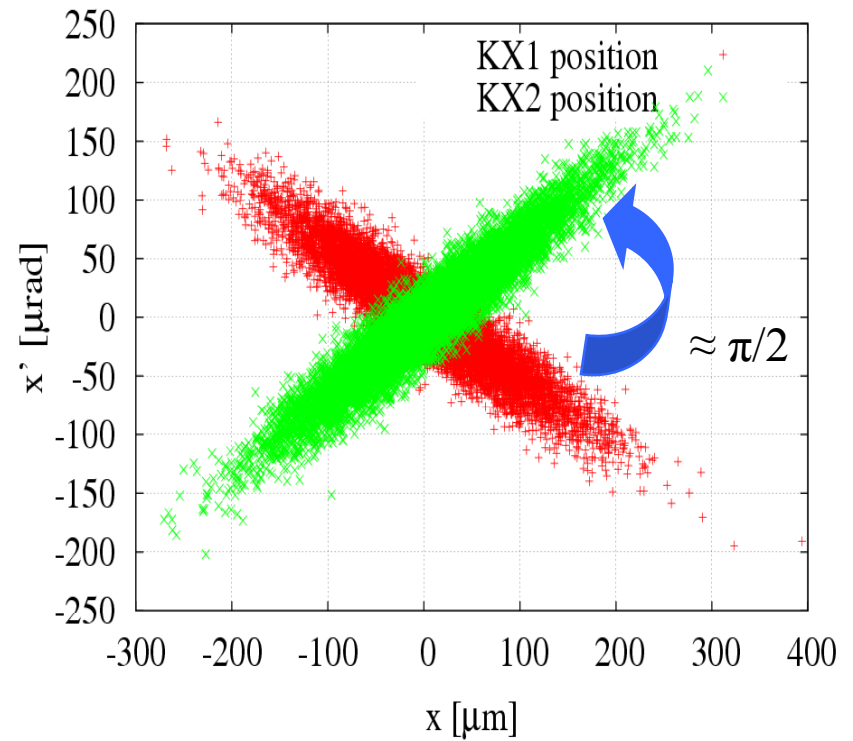
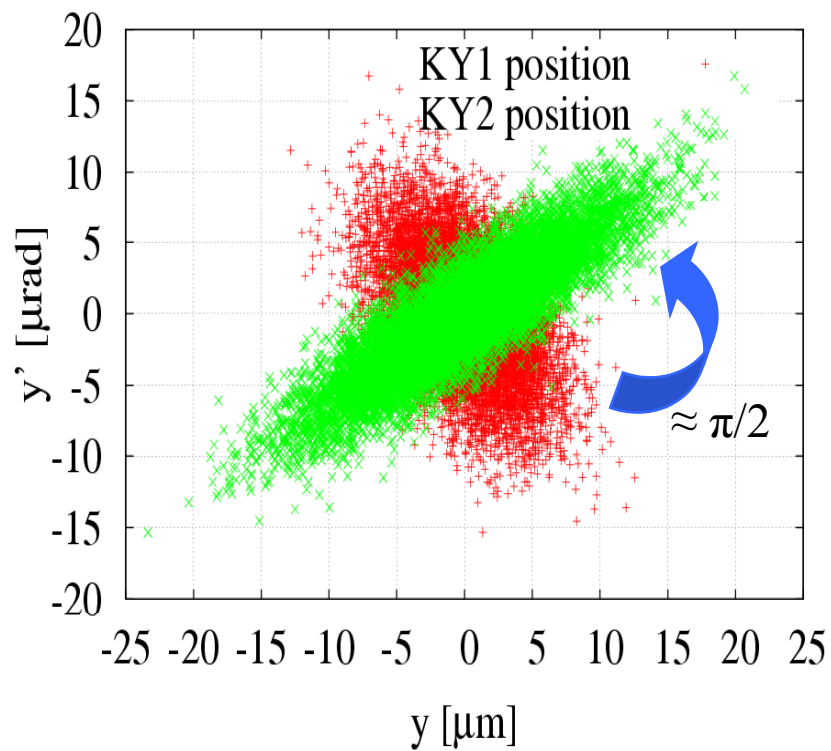

Phase advance between kicker pairs of $\approx \pi/2$