

# LP trigger status and plans

P. Colas

# Final mechanical/thermic design in progress

I r f u

cea

saclay

State-of-the art cosmic-ray trigger system

MPPC (Si-PM) via KEK

Temperature control by Peltier devices and thermistors

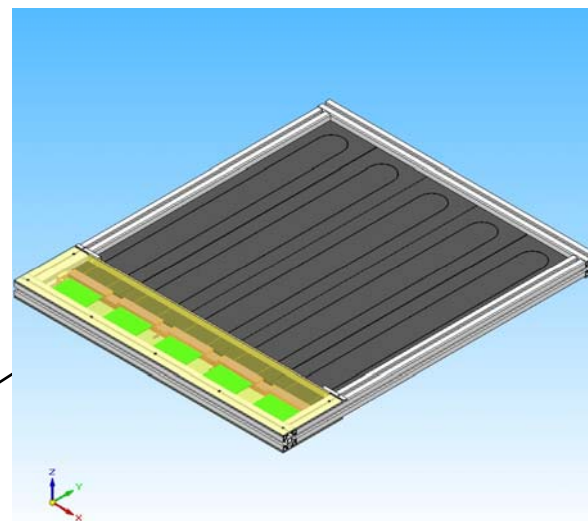
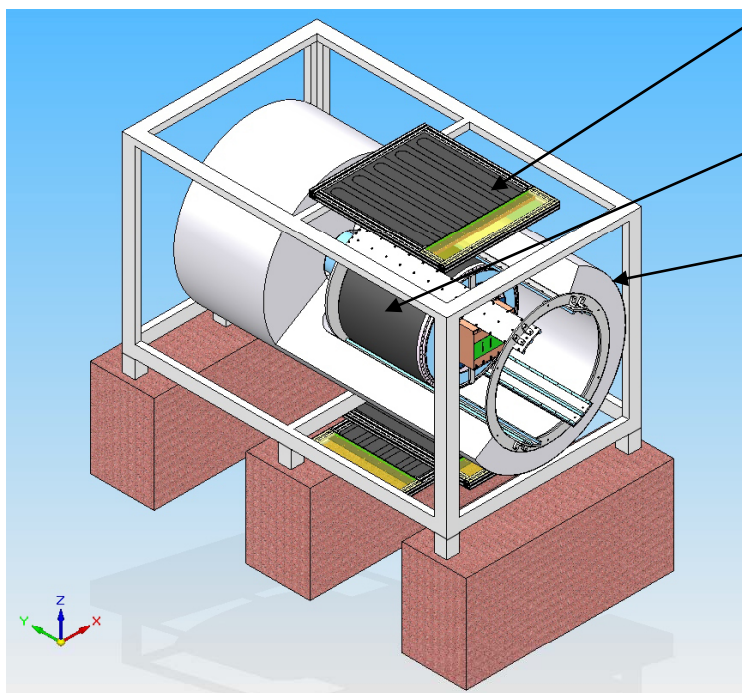

Field cage by DESY

PC-MAG magnet from KEK at DESY (EUDET)

Logic by FPGAs

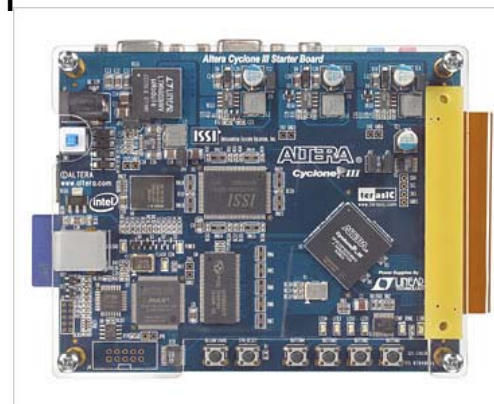

# The Large Prototype

I r f u

cea

saclay

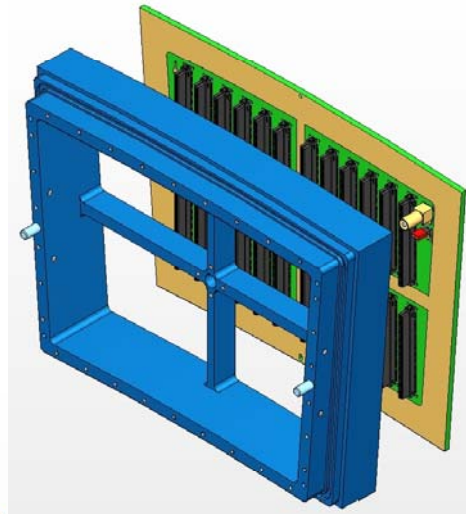

7 interchangeable modules

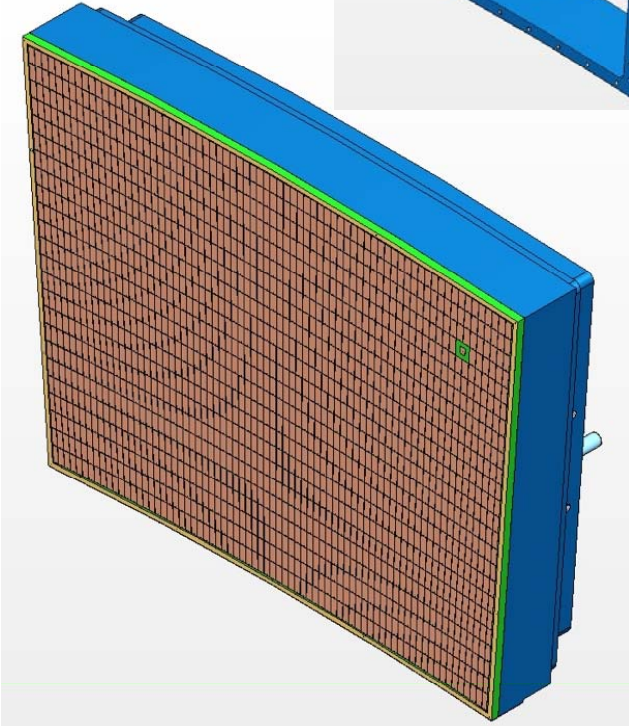

24 rows x 72 pads  
Av. pad size  $\sim 3.2 \times 7 \text{ mm}^2$

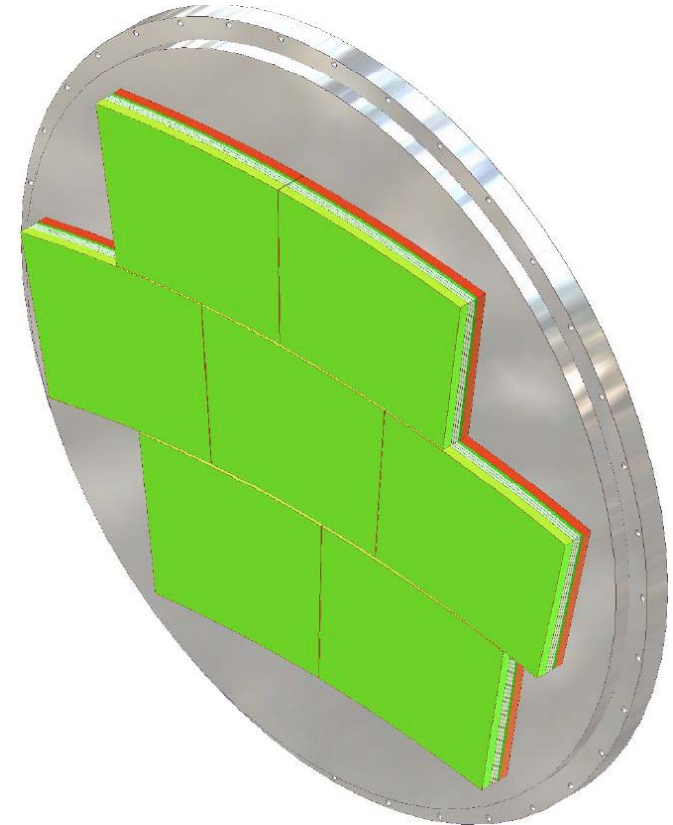

# Micromegas with TimePix

I r f u  
cead  
saclay

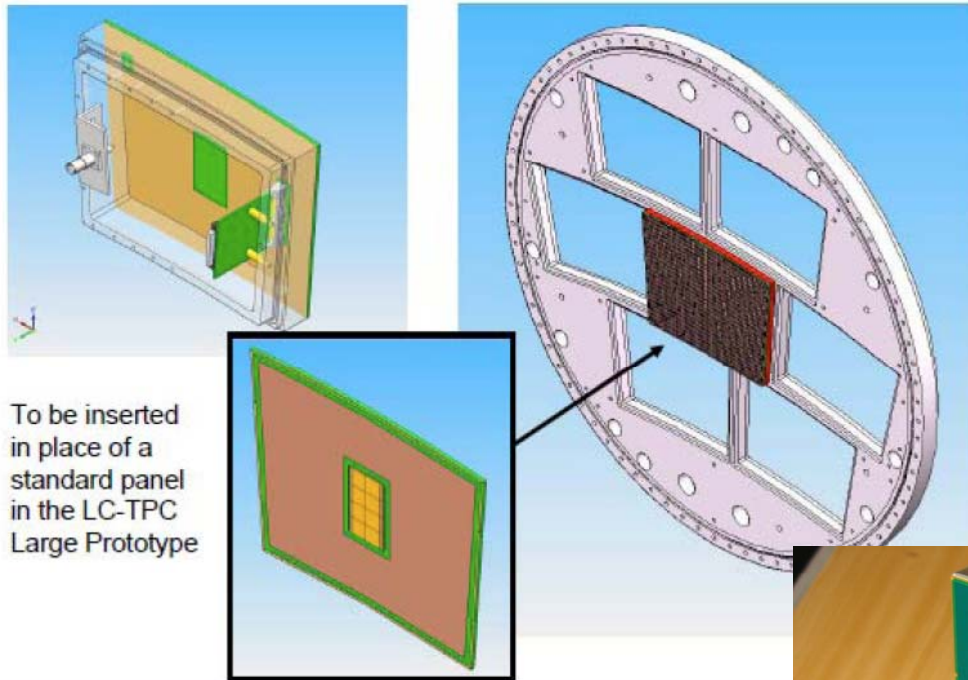

EUDET deliverable  
documentation being written

EUDET

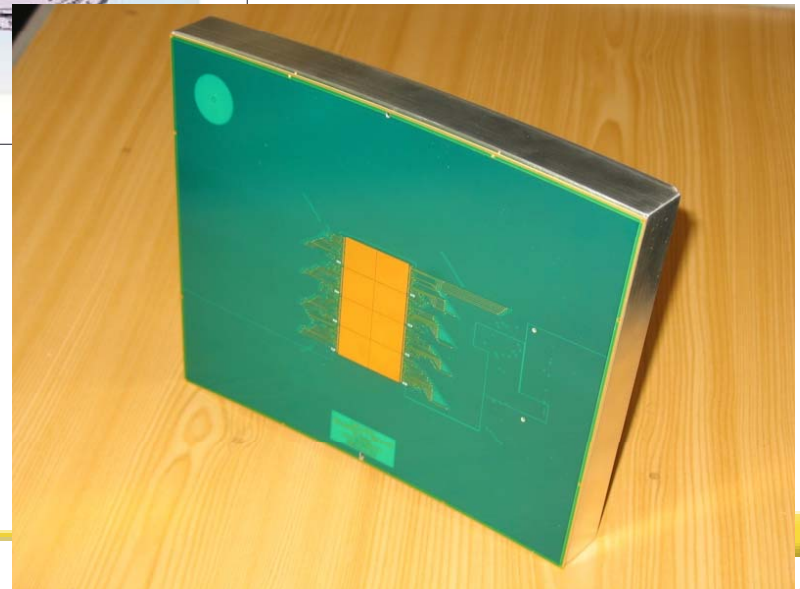

# Mounting of the Micromegas panel

I r f u  
cead  
saclay

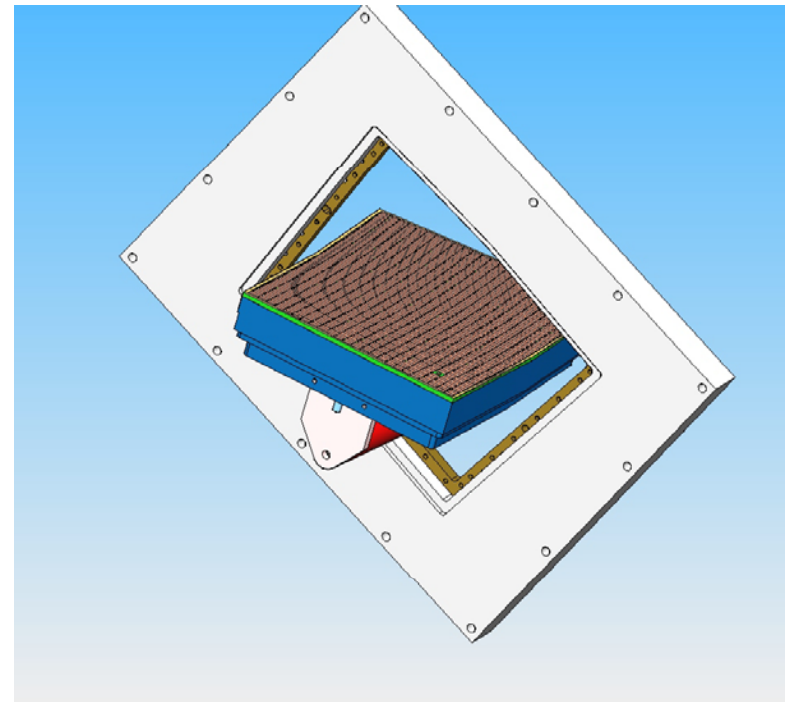
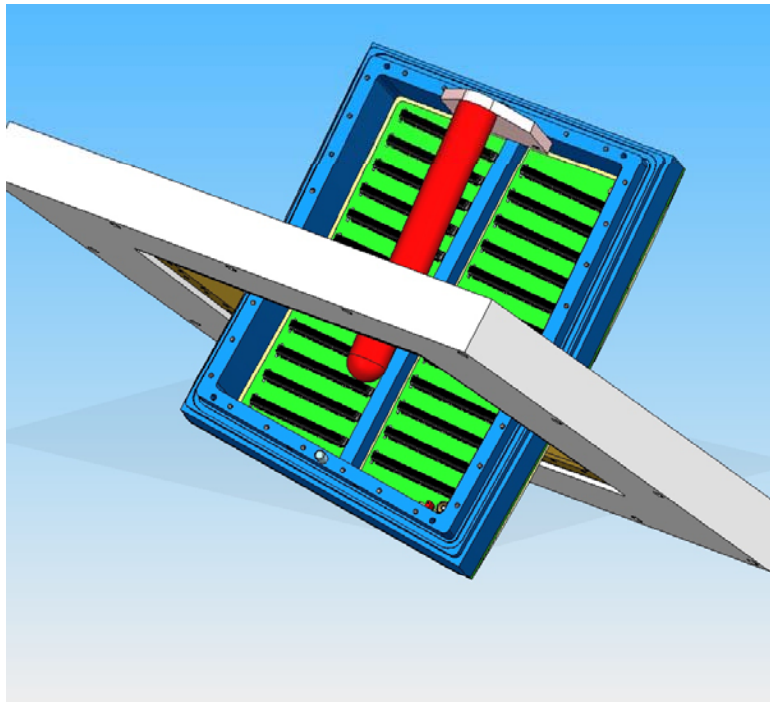

# Tentative schedule



- May 22: get Micromegas panels (Saclay routing)
  - Send one to Carleton (kapton + resistive coverlay)
  - Send one to Neuchatel (20 micron aSiH + 10 micron doped aSiH) if a solution is found for the adherence problem.
  - Keep one for tests with standard anode
- June 4: mechanics/thermics ready to be assembled.
- 20m cables:
  - 12 lemo cable for the 70V
  - 12 banana cables for the +-12V
  - 12 BNC coax cables for the signals
- May 28: Submission of trigger electronic cards (return from CAD)
- June 13 to 18: test electronic cards. Finish mechanical assembly.
- June 19-20 ship complete cosmic trigger to DESY. Ship also DAQ computer, power supplies, etc... (however if not ready by June 23rd, there might be a serious delay to have another opportunity for the shipment)