

CesrTA Status and Planning for FY08-09

David Rubin
Mark Palmer

Cornell University

2008 Joint DOE/NSF Review

Outline

- CEsrTA
 - CESR machine upgrades
 - Experimental Program
 - E-cloud simulation program
 - Collaborators
 - FY09 Milestones
- Budget
- Long term plans/synergies

Machine Upgrades

- Dipole and drift chambers with prototype (thin) RFAs are installed and beam tests are underway
- Design of hardware for reconfiguration of CESR for ultra low emittance is complete and fabrication is underway
- Design of beam line for xray beam size monitor complete with fabrication and installation summer 08
- Wiggler chambers with RFAs are under construction at LBNL
- Reconfiguration of IR and installation of instrumented chambers planned for July-September 2008
- RFA control and readout electronics beam tested this week
- RFA data acquisition under development
- Turn by turn/bunch by bunch BPM electronics characterized with beam June 08 with deployment during summer 08 shutdown and implementation October 08
- Survey network installation will be completed summer 08

Machine Upgrades - Low Emittance Optics

- CestrA Configuration:
 - 12 damping wigglers located in zero dispersion regions for ultra low emittance operation (move 6 wigglers from machine arcs to L0)

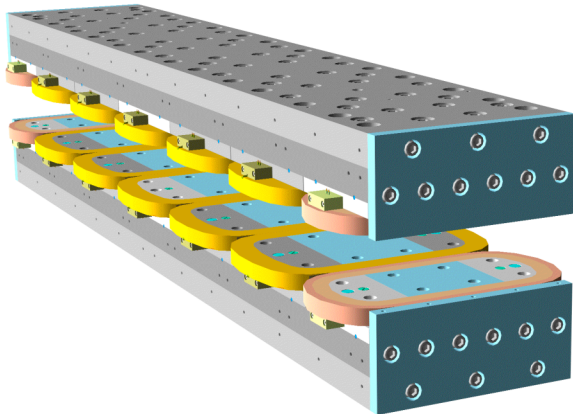

CESR-c Damping Wiggler

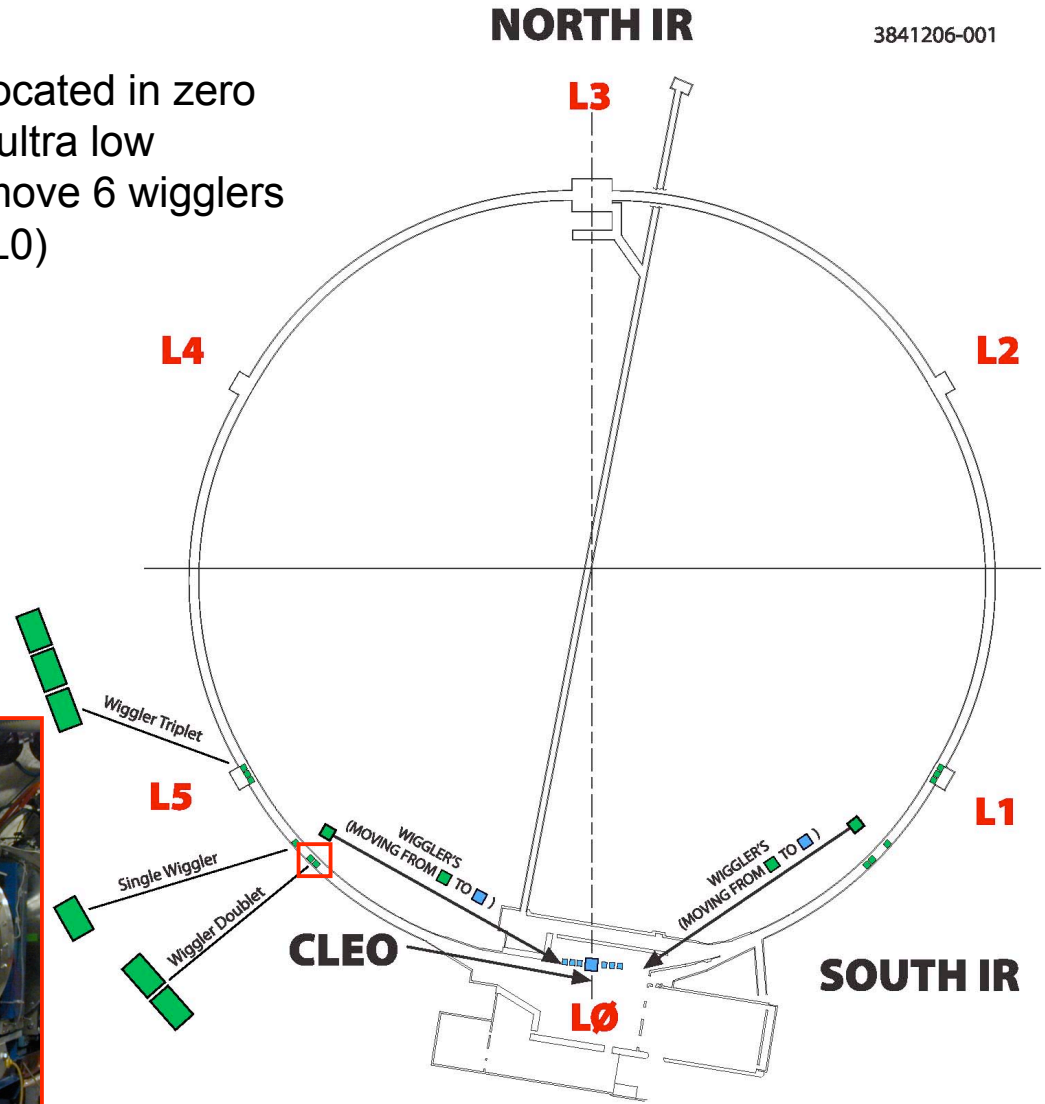

3841206-001

Machine Upgrades - L0 Wiggler Region

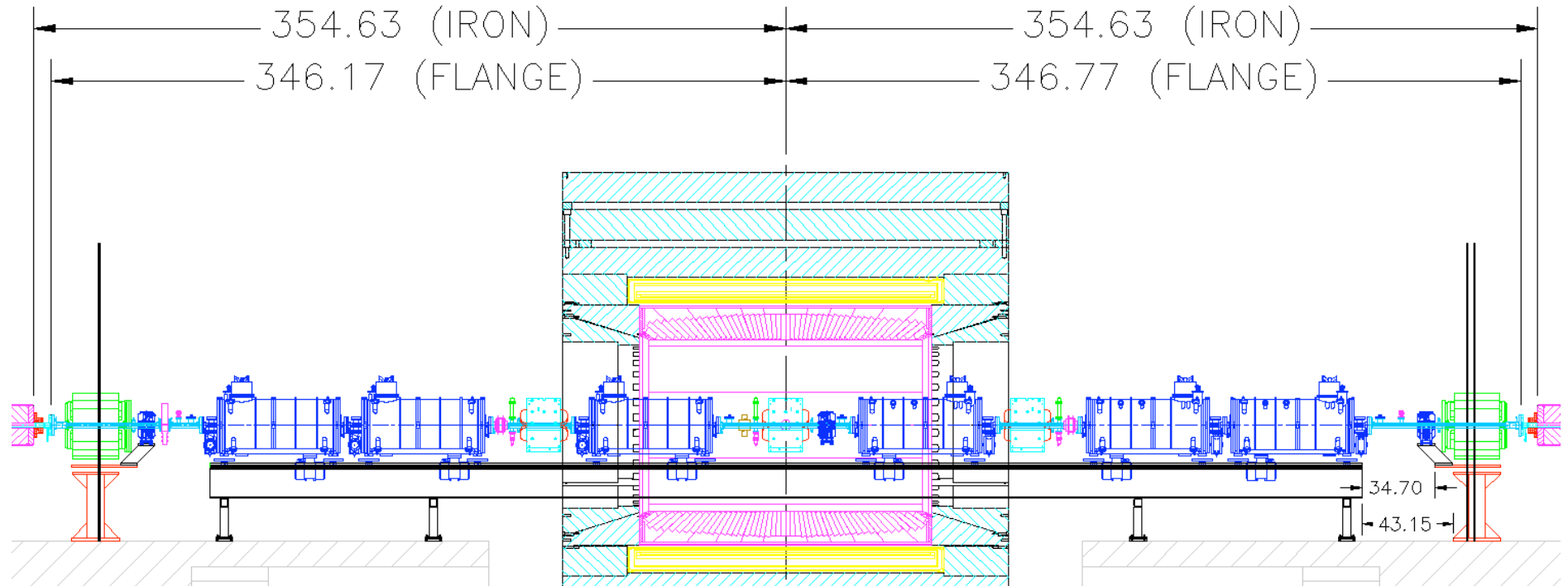

- L0 wiggler experimental region
 - Installation during July down
 - Heavily instrumented throughout with vacuum diagnostics
- Note: Part of CLEO will remain in place

Dipole RFA

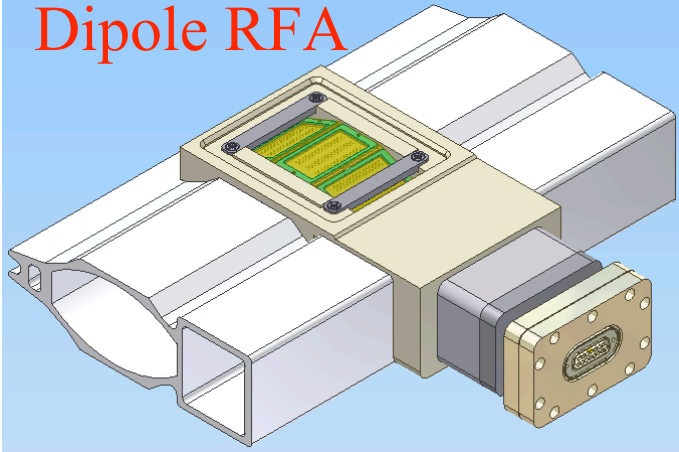

SC Wiggler Replacement Chambers

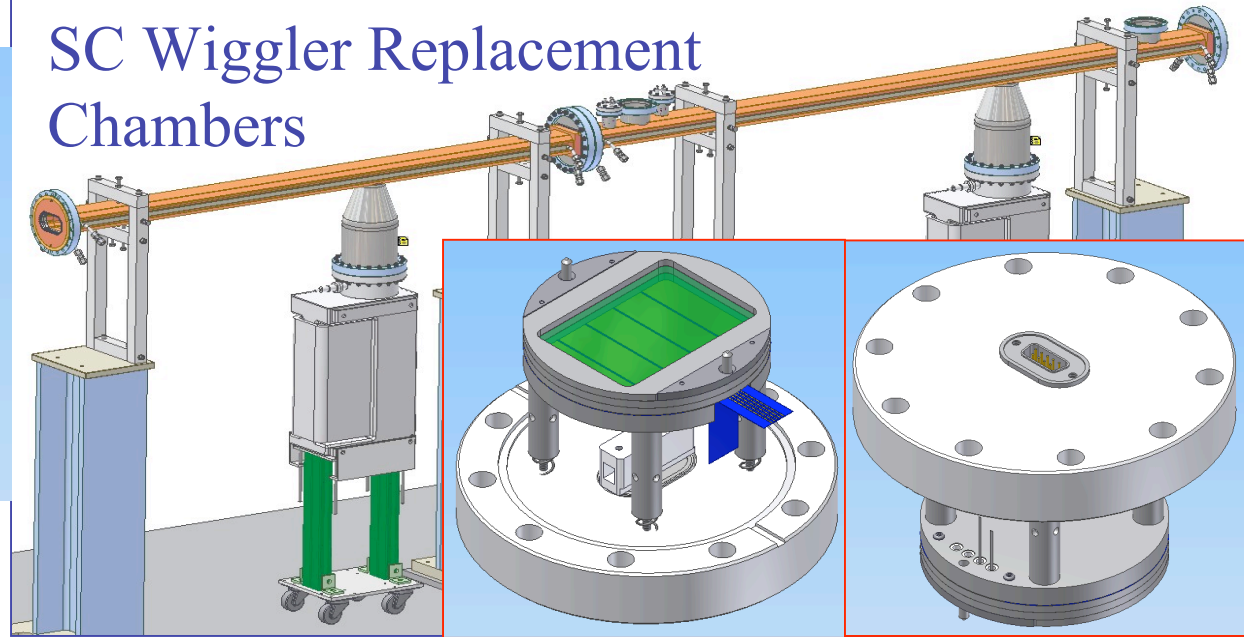

B12W Dipole Replacement Chamber

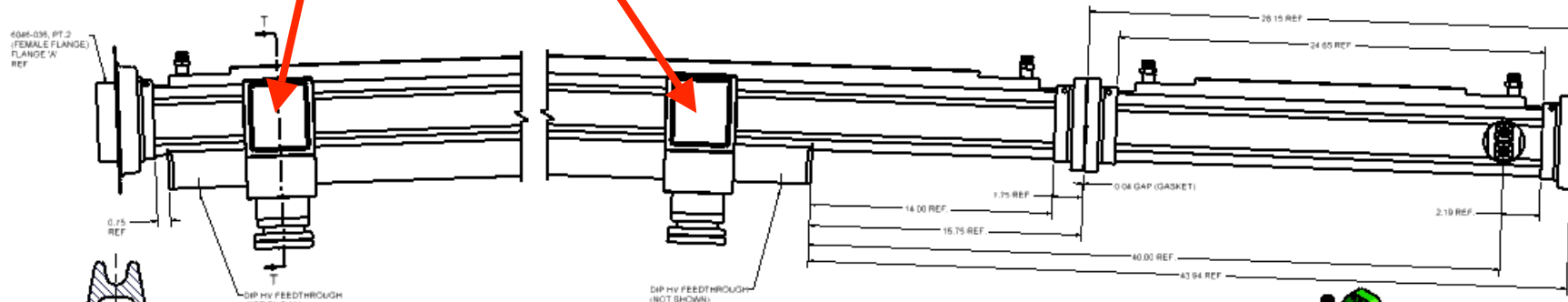

Experimental Program

- Low emittance tuning
 - Develop orbit response matrix machinery for calibrating BPM gain variation/tilt.
(Tested during June 08 machine studies)
 - Develop correction algorithms (orbit/coupling/dispersion)
Vetted by simulation - tested in machine studies
 - Develop *fast* (AC) dispersion measurement technique
Drive beam at synchrotron tune & measure transverse response
 - Develop analysis of zero vertical corrector orbits and dispersion to identify misaligned quads and rolled bends

Experimental Program x-BSM

- X ray beam size monitor
 - 32 channels are from Hamamatsu InGaAs photodiode array
 - Negative going signals indicate xrays
 - Single bunch
 - Inferred beam size $\sim 170\mu\text{m}$
 - 5.3GeV

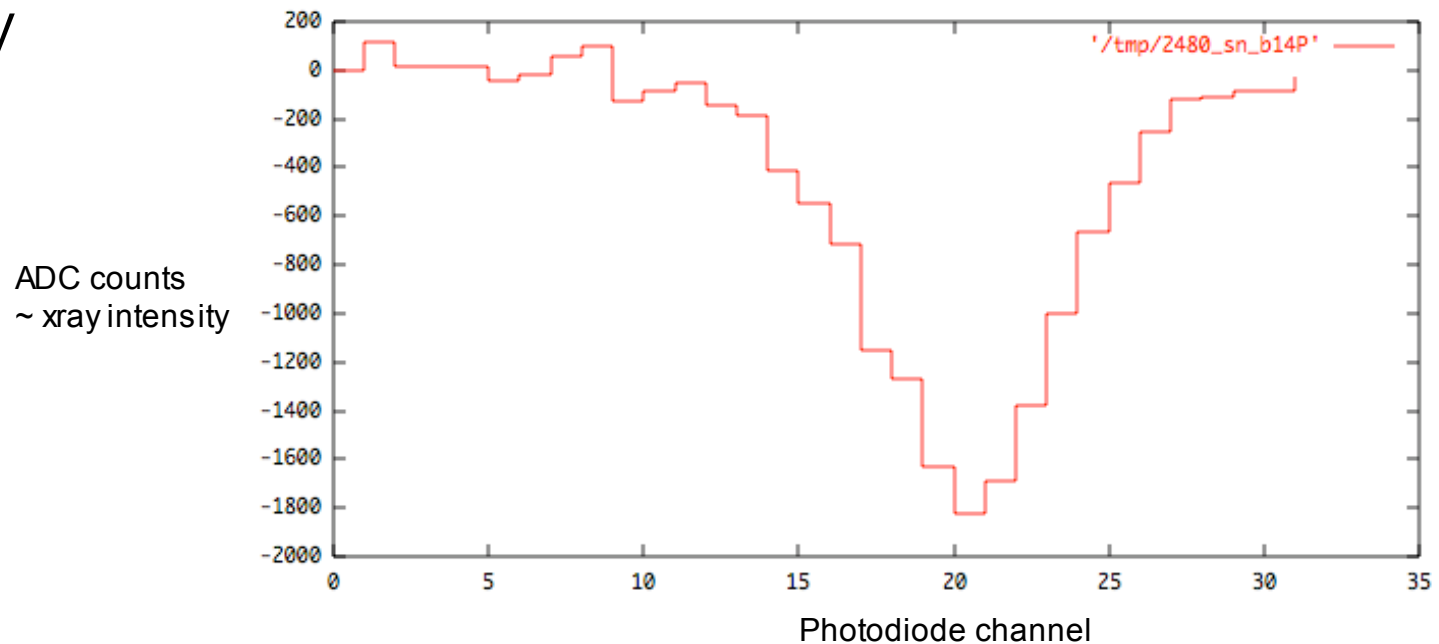

Experimental program - xBSM detectors

Response to 6 consecutive CESR pulses (spacing = 14ns)

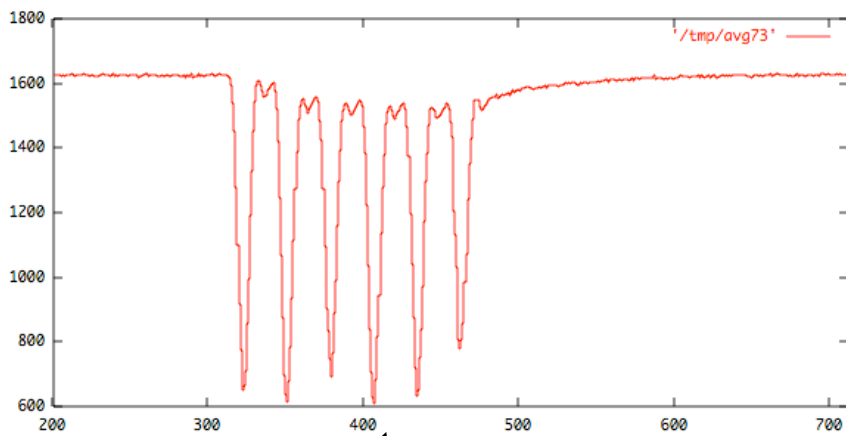

Emcore GaAs
singleton photodiode
46um diameter

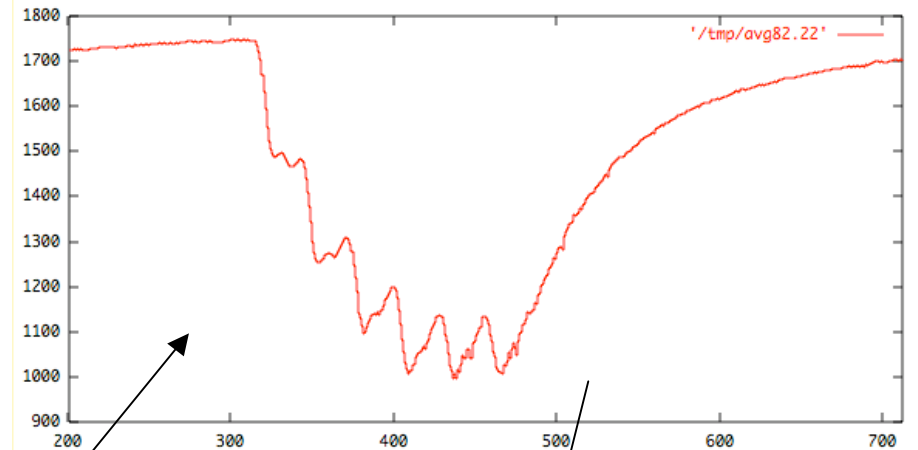

Deconvolve tail function

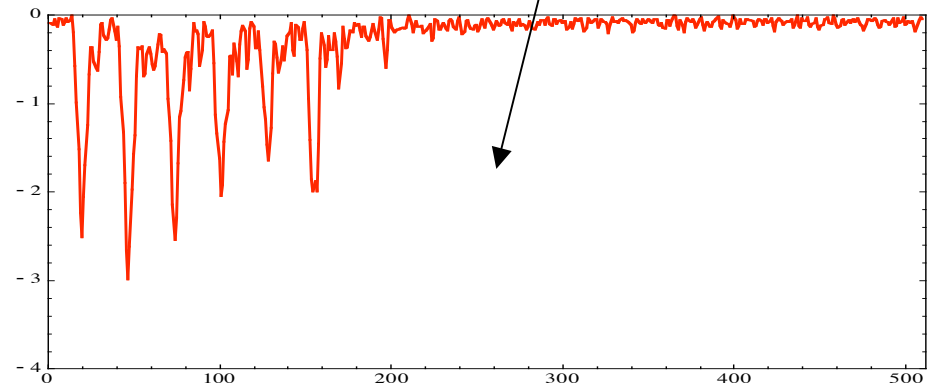

- Electron cloud
 - Beam dynamics
 - Witness bunch studies measure ring-integrated cloud density vs. time (growth and decay) as a function of bunch charge, beam size, beam energy and particle species.
 - Measurements of instability thresholds and incoherent emittance growth give additional information on beam-cloud dynamics
 - Cloud growth
 - RFAs deployed in dipole, drift, quadrupole, and wigglers probe time average local cloud density and energy spectrum as a function of beam parameters, magnetic field and vacuum chamber surface preparation.
 - Measurements at different beam energies and bunch configurations, and with electrons as well as positrons, can help sort out relative contributions to the cloud from photoemission vs secondary emission.

Electron cloud - Witness bunch studies I

Positrons

E=2.1GeV

Bunch 1 0.5mA reference bunch

Bunches 2-11, 1mA/bunch

0.5mA witness bunch

e+ Vertical Tunes E=2.1GeV
 Bunch 1 0.5mA reference bunch
 Bunch 2-11 1mA e- cloud generating bunches
 0.5mA witness bunches

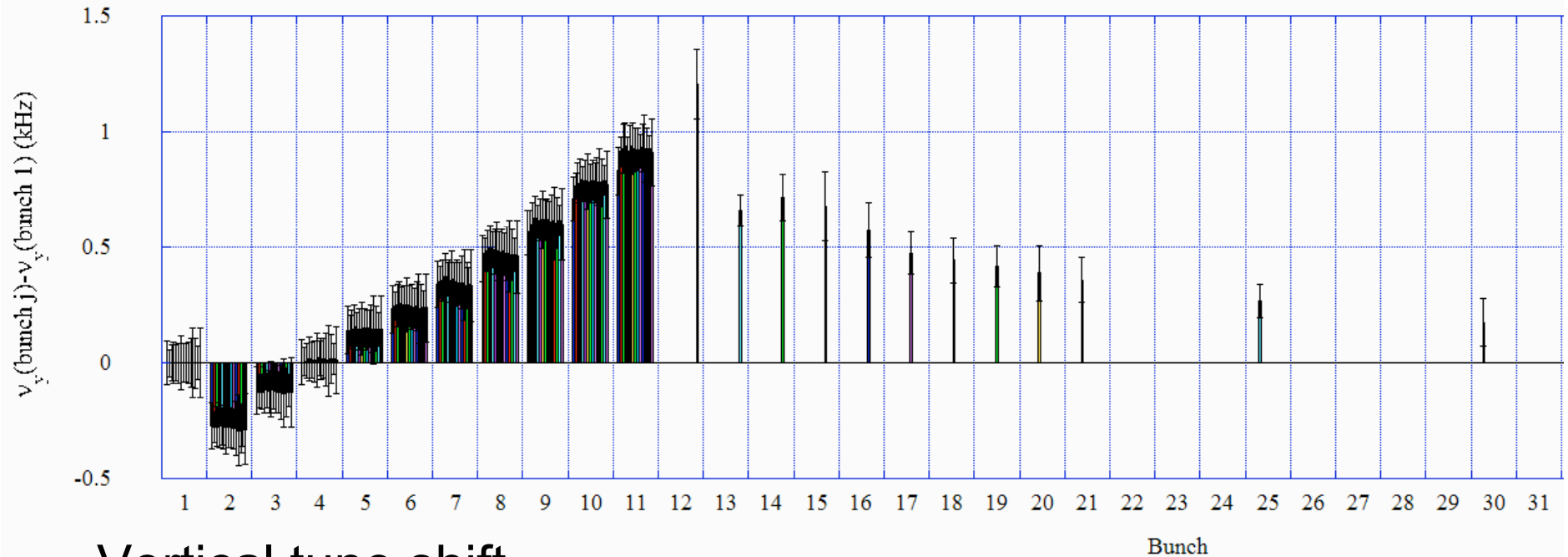

Vertical tune shift

Electron cloud - Witness bunch studies II

Positrons

E=2.1GeV

Bunch 1 0.5mA reference bunch

Bunches 2-11, 1mA/bunch

0.5mA witness bunch

e+ Horizontal Tunes E=2.1GeV
 Bunch 1 0.5mA reference bunch
 Bunch 2-11 1mA e- cloud generating bunches
 0.5mA witness bunches

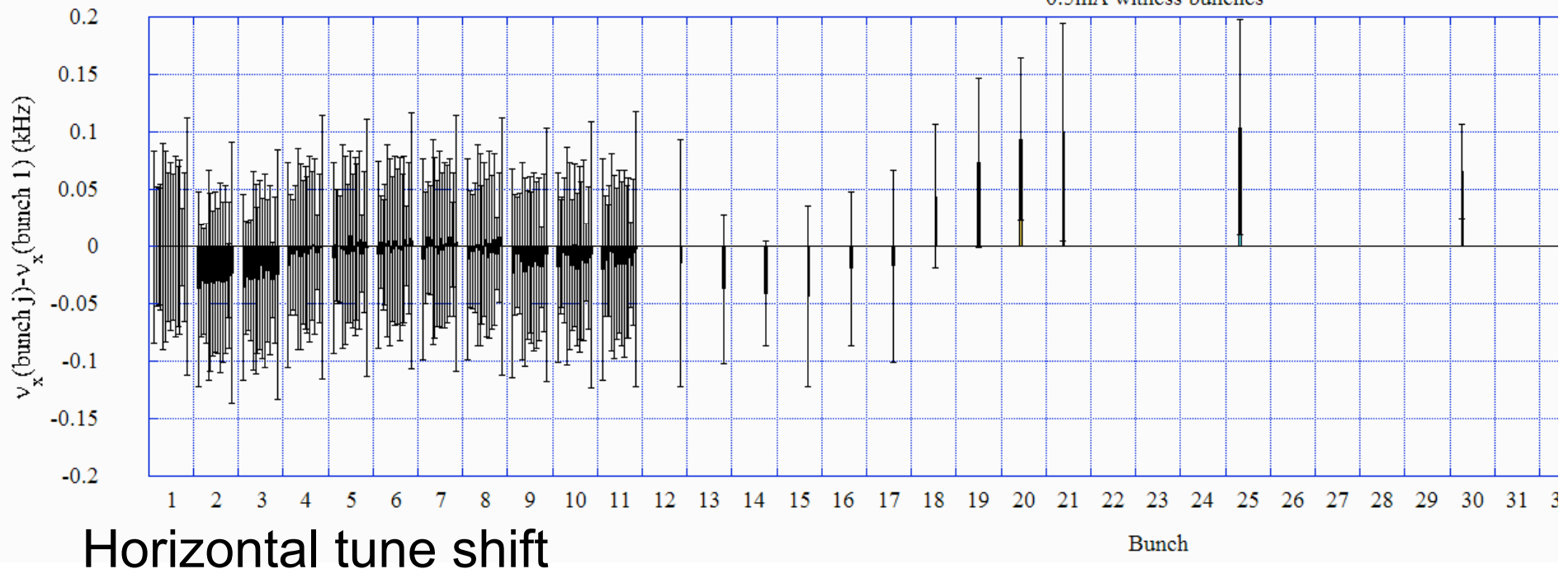

Electron cloud - Witness bunch studies III

Electrons

E=2.1GeV

Bunch 1 0.5mA reference bunch

Bunches 2-11, 1mA/bunch

0.5mA witness bunch

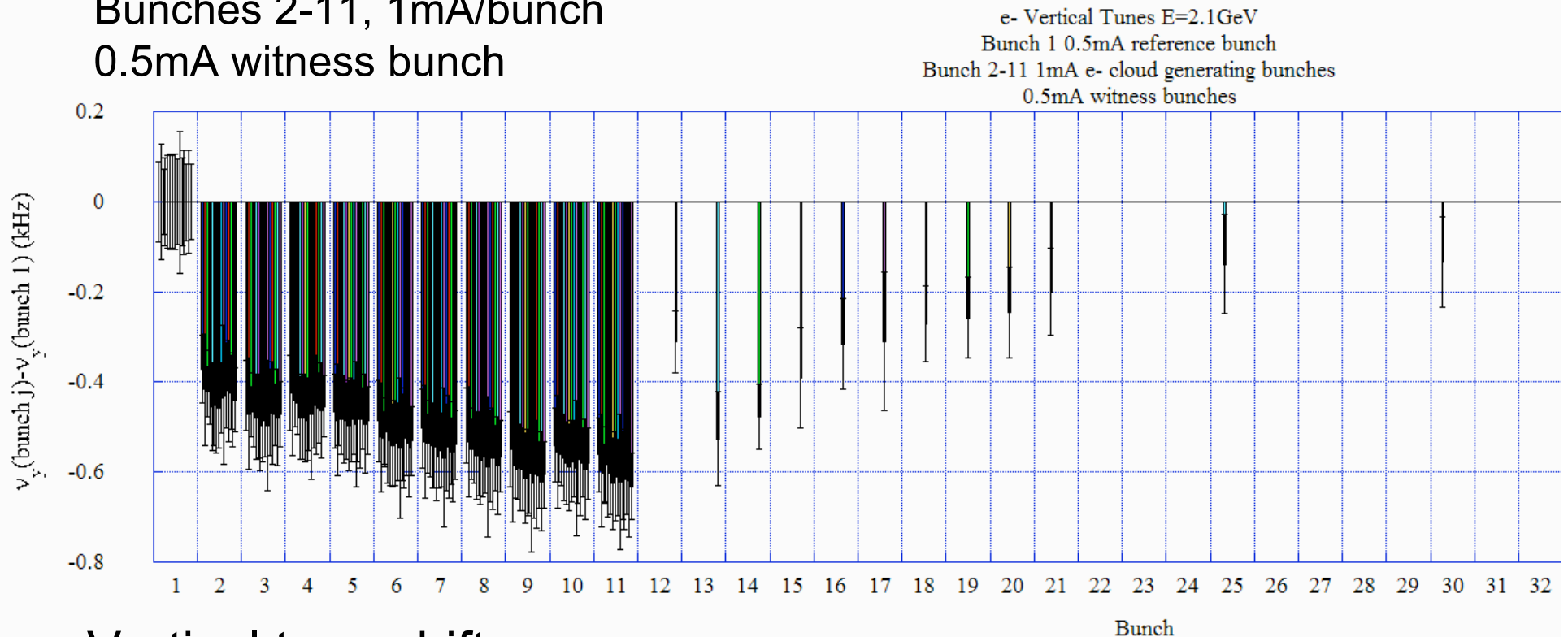

Vertical tune shift

Electron cloud - Witness bunch studies IV

Positrons

E=2.1GeV

Bunch 1 0.5mA reference bunch

Bunches 2-4, 3mA/bunch

0.5mA witness bunch

e+ Vertical Tunes E=2.1GeV
 Bunch 1 0.5mA reference bunch
 Bunch 2-4 3mA e- cloud generating bunches
 0.5mA witness bunches

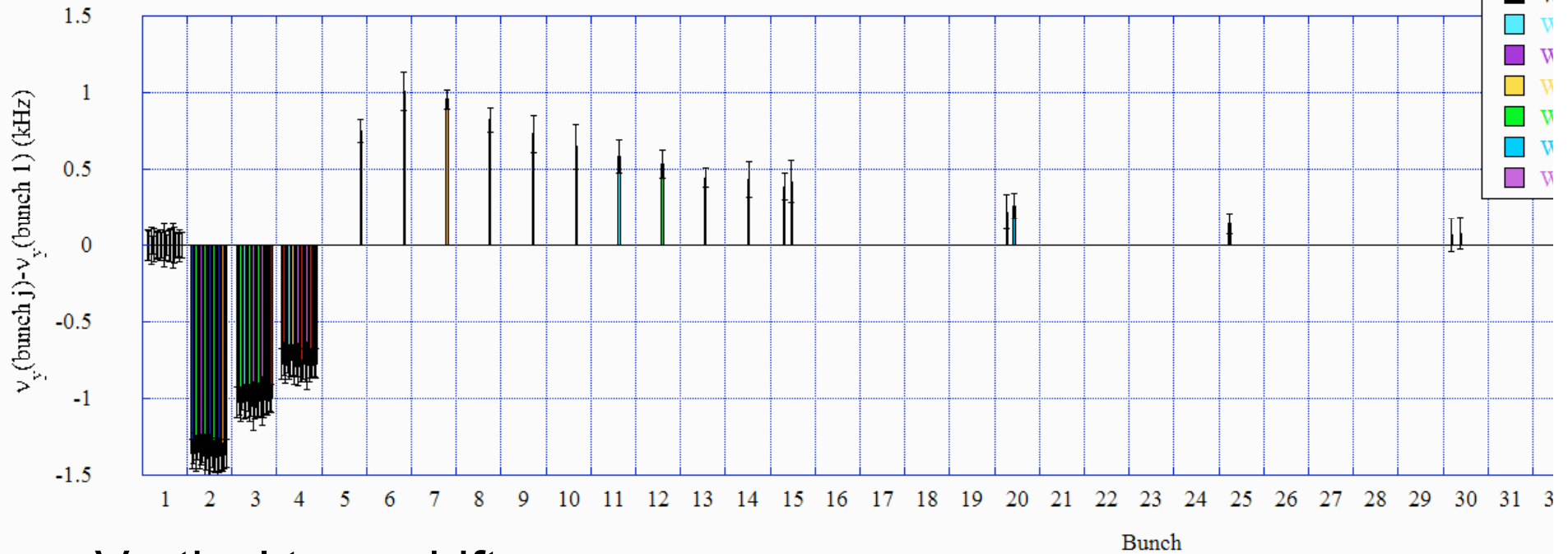

Vertical tune shift

Electron cloud - Witness bunch studies V

Positrons

E=5.3GeV

Bunches 1-10, 0.75mA/bunch

0.75mA witness bunch

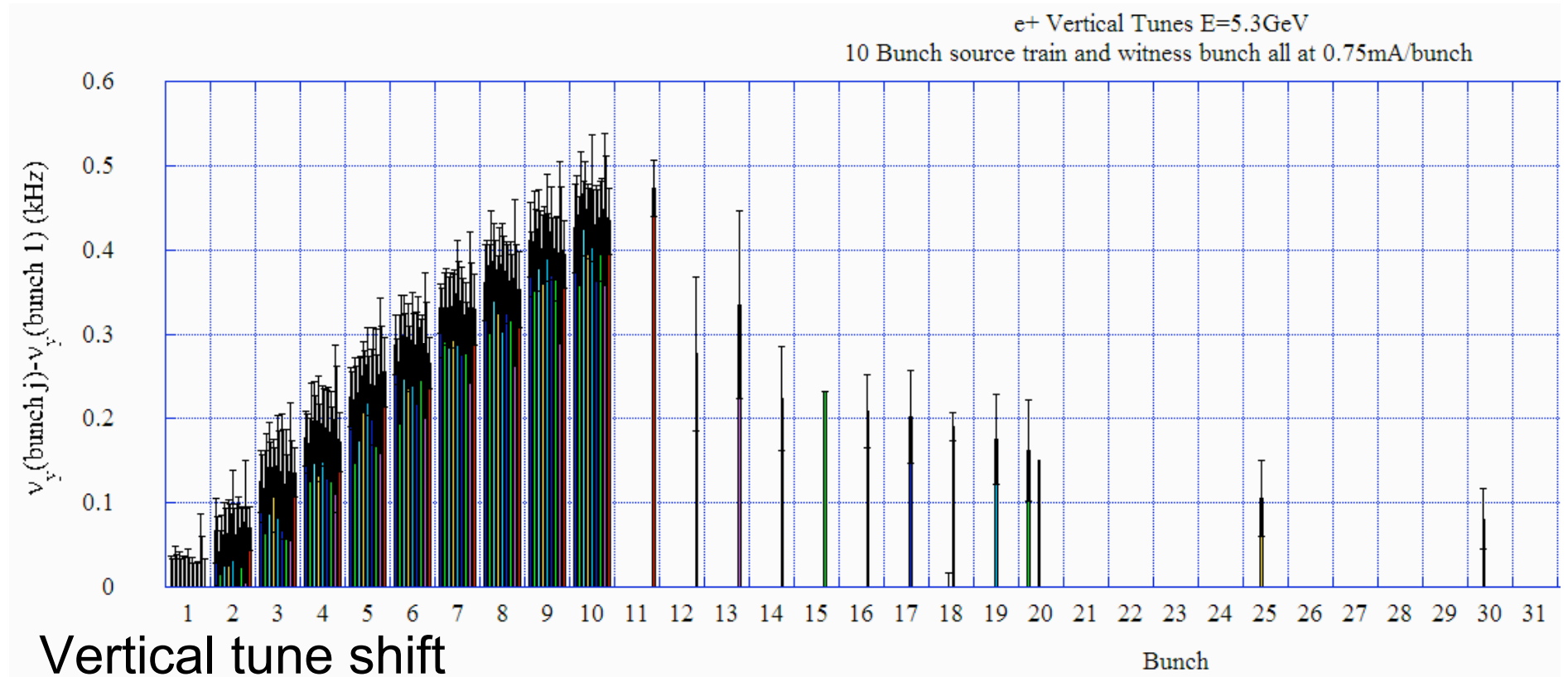

Simulation - Goals

- Understand cloud buildup in drift, quadrupole, **dipole and wiggler** sections of CEsrTA, with different cloud suppression techniques.
- Understand interaction of the cloud and the beam in CEsrTA.
- Benchmark cloud buildup and cloud dynamics simulations using CEsrTA data, in order to develop confidence in the application of these simulations to predict cloud behavior in the ILC damping ring.

Simulation goals

Simulations at Cornell will focus on the following needs:

- Defining and guiding the experiments and related measurements needed to fulfill the overall CesrTA program goals.
- Providing support for understanding the response of instrumentation and diagnostics in terms of fundamental beam and cloud properties
- Understanding the results of experiments in terms of simulation codes, thereby benchmarking the codes for use at ILC and elsewhere

CesrTA Simulation conditions

Common information needed for all simulations:

- Database of CESR elements, vacuum chamber sizes and surface materials, magnetic fields, radiation intensity on the surface
- Geometry of RFA-instrumented chambers
- SEY model for each surface material
- Experimental conditions (e.g., energy, emittance, chamber condition, lattice, bunch pattern, etc.) for each set of measurements to be done

This information will be posted on the CesrTA Cloud Simulation web page

<https://wiki.lepp.cornell.edu/ilc/bin/view/Public/CesrTA/EcloudParams>

so that it is available to all collaborators. Experimenters should document the experimental conditions and results in electronic logbooks, and (linked) at the web site.

Current Simulation plans

- Simulation plans related to Cesr-TA :
 - Build-up and tune shift simulations with CLOUDLAND; Build-up, tune shift and instability simulations with POSINST (SLAC, Cornell)
 - E-CLOUD V3.2 simulations of cloud buildup and tune shifts (Cornell)
 - RFA modeling (VF OPERA 3D model) (Cornell)
 - Coherent tune shift, coupled bunch instabilities, strong head-tail, incoherent emittance growth-(KEK)
 - Build-up simulations, PEP-II chicane simulations, tune shift, wiggler and dipole edge effects, single and multibunch coherent effects, incoherent emittance growth (using WARP/POSINST); Microwave transmission diagnostics (using VORPAL) (LBNL)
 - Electron cyclotron resonant enhancement of electron cloud-3D field calculations using WARP3D- (LBNL)

Plans for future simulations at Cornell will be coordinated with ongoing work at other labs to optimize the overall program.

Collaboration

- Training on use of new survey instruments (LBNL)
- Wiggler instrumented vacuum chambers (LBNL)
- Simulation support and training (SLAC/LBNL)
- Machine experiments
 - Tune scan to probe dynamical effects of E-cloud (KEK)
 - Microwave measurement of cloud density (LBNL)
 - E-cloud induced tune shift (Alfred/FNAL)
- Instrumented dipole chicane (SLAC)
- Chamber coatings (SLAC)
- E-cloud mitigation hardware (FNAL)
- Xray beam size monitor (KEK)

CesrTA Collaboration Efforts

- Collaborators from Alfred Univ., FNAL, KEK, and LBNL have participated in June `08 run
 - EC Measurements
 - X-ray Beam Size Monitor
- Discussions underway for coordinating EC experimental program with CERN, BNL, FNAL, and KEK efforts
- Work underway to transfer PEP-II EC experimental hardware to CESR for ongoing experimental program
- EC Simulation Group
 - Meeting at ILC08 next week:
Participants from BNL, CERN, Cornell, FNAL, KEK, LBNL, SLAC
- LET Group
 - Also meeting at ILC08 next week:
Participants from BNL, Cockcroft, Cornell, KEK, SLAC

Wiggler Vacuum Chamber Collaboration

- Cornell, KEK, LBNL, SLAC
- First two chambers in welding phase
- One VC to be TiN coated at SLAC
- Detectors to be added and chambers installed in wigglers at Cornell

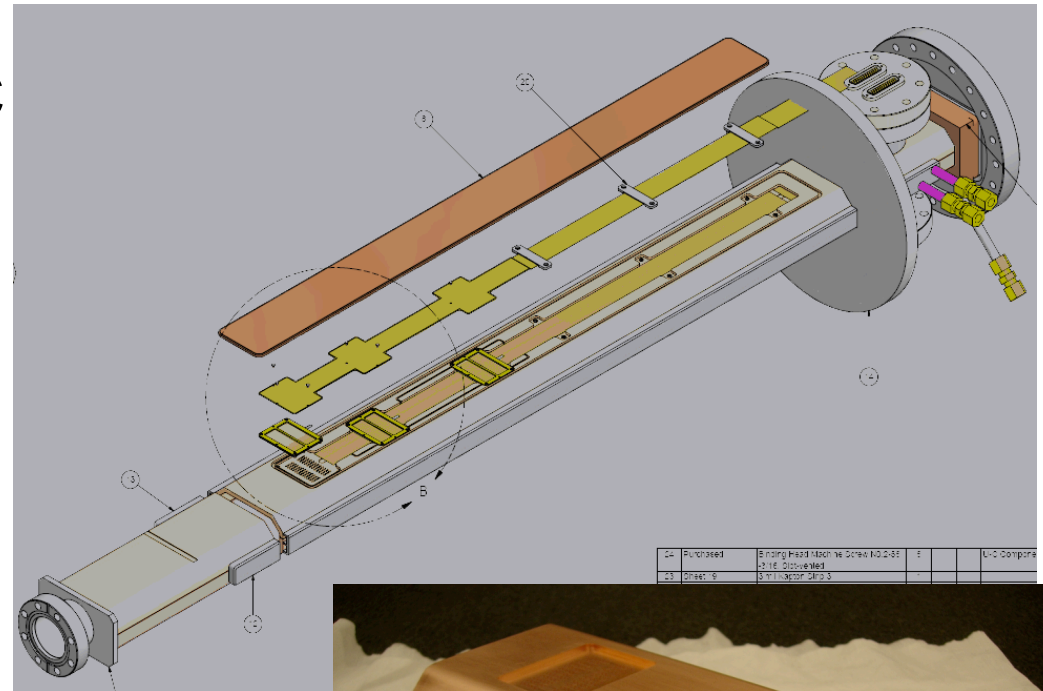

Machining & Welding
Test Piece (LBNL)

Electron cloud mitigation tests: chicane in PEP-II

PEP-II LER arc/straight

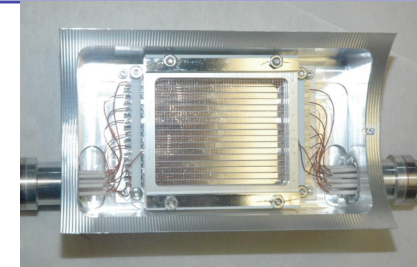
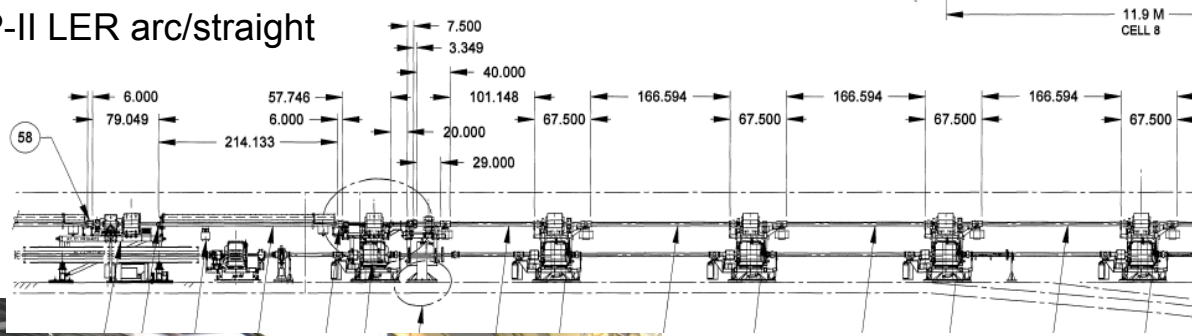

Stripe electron monitor

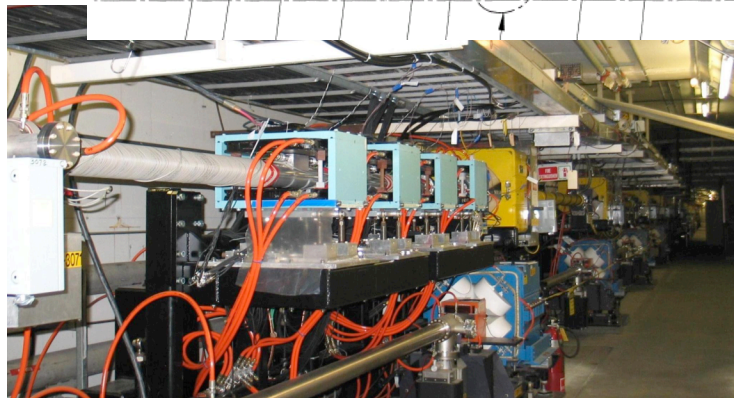

4-dipole chicane in the PEP-II LER

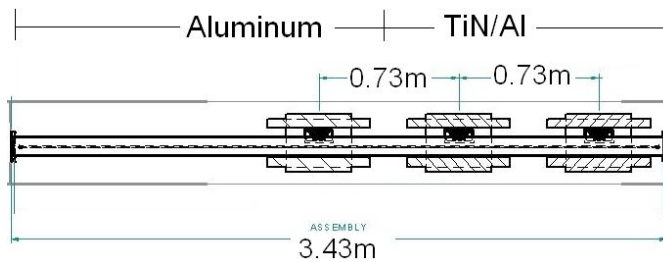

Test chamber Al and TiN-coated

Mitigation tests in ILC magnetic field

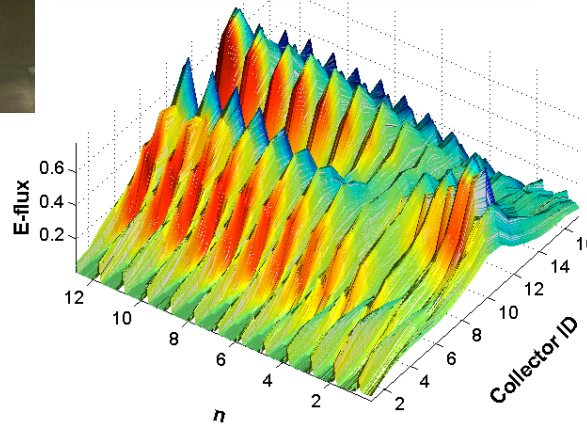

Observed new resonance: Electron current peaks at defined B values (n)

Aluminum surface

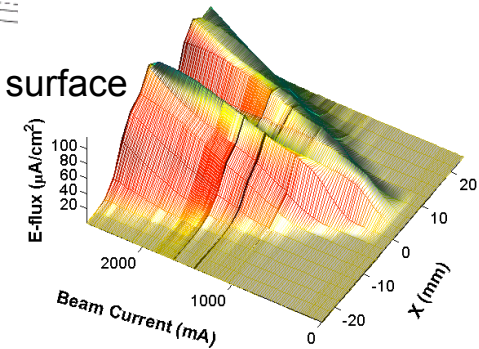

TiN surface much reduced signal with respect to Al

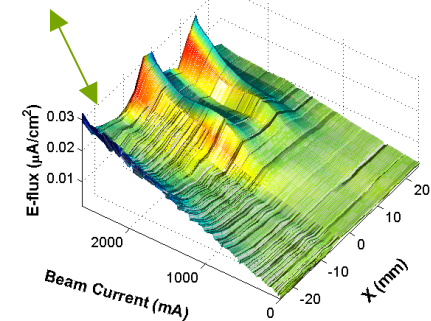

- Measurements at CEsrTA
 - Characterization of electron cloud growth in all magnetic guide field elements and dependence on bunch charge, spacing, emittance etc.
 - Experimental study of beam dynamics effects of electron cloud, such as coherent tune shifts, single and multi-bunch instabilities, incoherent emittance dilution
 - Development and tests of mitigation hardware which could be used in ILC damping rings, such as chamber coatings and clearing electrodes.
- Simulation
 - Test and benchmark codes against measurements
 - Cloud evolution and density in dipoles, wigglers, ...
 - Cloud induced tuneshifts, emittance dilution, instabilities
- ILC damping ring design will rely on well vetted simulations to predict the size of the effects and our ability to mitigate them in the ILC damping ring

FY09 Goals

- Beam- based and instrumental alignment to achieve ultra-low emittance
- Commission electron and positron x-ray beam size monitors
- Measurement of local e-cloud density and wall current energy spectrum, as a function of beam energy, bunch spacing and configuration, intensity, emittance particle species and magnetic field.
- Experiments at lowest achieved emittance to characterize e-cloud ring averaged density vs time (from witness bunch studies), instability thresholds and emittance dilution
- Comparison of above measurements and experiments with simulation, to provide benchmarking, and refinement of physics models in the simulations as required.
- Explore e-cloud growth and mitigation techniques in wigglers at 5GeV

FY09 Budgets

ART Funding (DOE):

WBS	Description	FY09 FTE	Direct Labor (K\$)	M&S (K\$)	Indirect (K\$)	Total (K\$)
1.4.1.1	DR Studies of Electron-Cloud Instabilities (CESR-TA)	7.49	959	451	590	2,000
1.4.1.2	CESR-TA Collaborative Effort @ LBNL	0.5	142	35	82	259
1.4.1.3	CESR-TA Collaborative Effort @ Cornell	0	0	31	19	50
1.4.1.4	CESR-TA Collaborative Effort @ SLAC	0.5	120	5	78	203
1.4.1	Total	8.49	1,221	522	768	2,511

FY09 NSF Funding for ILC Damping R&D and CESR-TA:

WBS	Description	FY09 FTE	Direct Labor (K\$)	M&S (K\$)	Indirect (K\$)	Total (K\$)
1.4.1.1	DR Studies of Electron-Cloud Instabilities (CESR-TA)	34.5	3,548	2,951	2,001	8,500

Long Term Plans

- At the conclusion of the CesrTA program Cornell will have developed local expertise
 - in electron cloud physics - instrumentation, measurements, simulation, and mitigation
 - Low emittance tuning - tuning algorithms, beam based alignment, instrumentation for tracking dispersion, and beam size
- We look forward to a continuing role in linear collider damping ring design and R&D

Synergies

- CsrTA R&D program will have application beyond damping rings
 - Understanding of electron cloud dynamics and its mitigation is critical to high current proton accelerators (LHC, Project X), and electron accelerators (Super KEKB)
 - The ability to achieve and then preserve ultra-low emittance is essential to light sources
 - Instrumentation for: single pass - single bunch measurements of position, tune, beam size has applications in light sources (ERL, XFEL)

as well as to linear collider damping rings