



DHCAL proposal for ILD

Imad Laktineh

IPN Lyon

For the DHCAL working group

Parc de la tête d'or à Lyon

LOI contents

- Motivations
- Baseline sensitive medium
- Readout electronics
- Mechanical structure
- Integration
- Needed R&D

Motivations

- High segmentation $1 \times 1 \text{ cm}^2 \rightarrow$ better PFA application.
- Semi-digital readout \rightarrow good energy resolution with little effort for calibration.
- Large area gas detectors provide more homogenous sensitive medium. No sensitivity to neutrons

Sensitive medium baseline*

GRPC is the baseline choice:

1. Efficient ($>90\%$)
2. Limited dead zone ($<1\%$)
3. Low cost (< 200 euros/m²)
4. Easy to build
5. Long experience (BELLE,ALICE,OPERA...)

Detection rate (< 100 HZ/cm² @ high efficiency)

**Other gaseous detectors are also being investigated: μ MEGAS, GEM*

Sensitive medium baseline



GRPC



MGRPC

Readout electronics

ASICs : HARDROC

- 64 channels
- 3 thresholds
- Gain correction for each threshold → uniformity
- Power pulsed, low consumption : $<10 \mu\text{W}/\text{ch}$
- Daisy-chained : allowing to connect many ASICs and hence reducing cables → hermicity

Electronics board :

- Thin board (800 μ), buried vias
- 6 or 8 layers, low x-talk
- stitchible → large electronics boards

Readout electronics

PWR ON

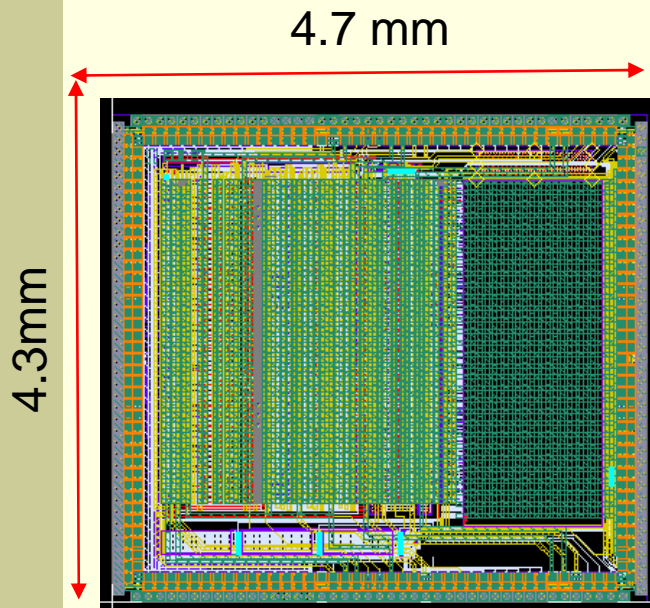

4.7 mm

4.3mm

HR2



- Power pulsing was tested in test board
- we intend to test it in beam conditions soon

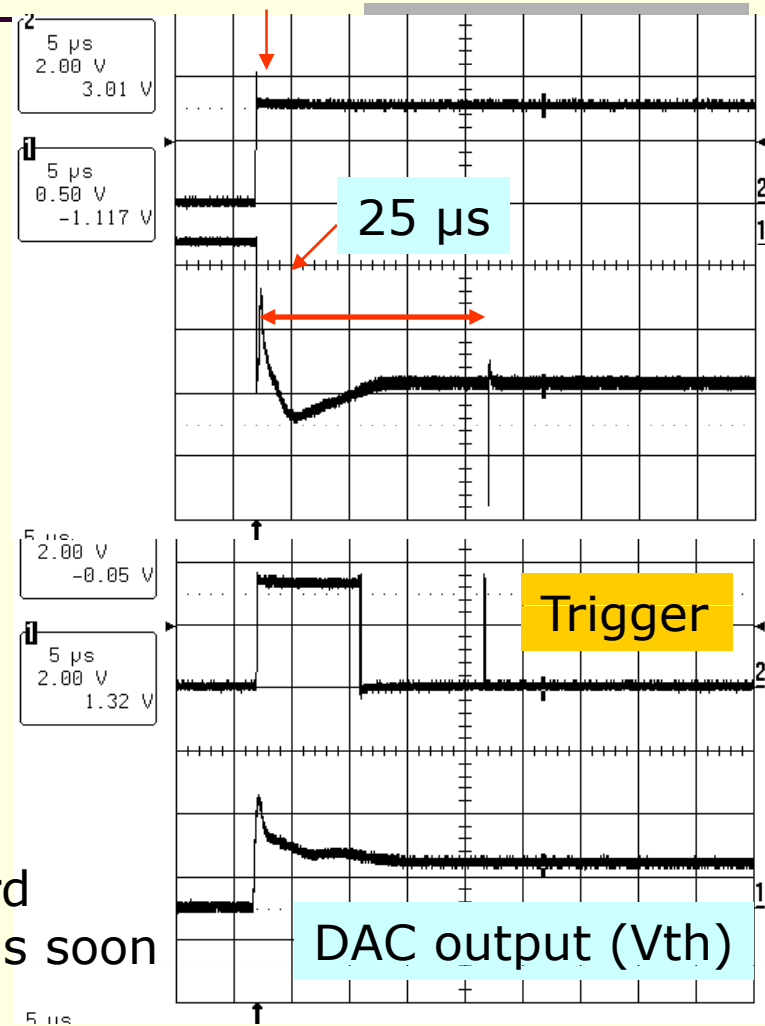

Readout electronics

1 M



DIF

Slab 1

Slab 2

Track length = 4 M

PCBs
connected with
0 ohms
resistors

Readout electronics

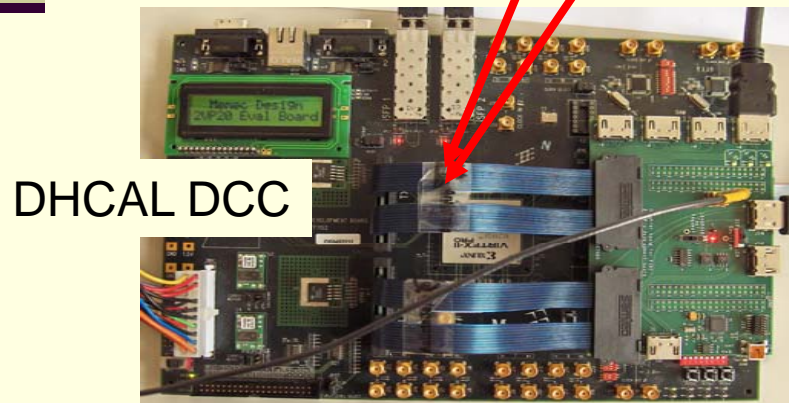
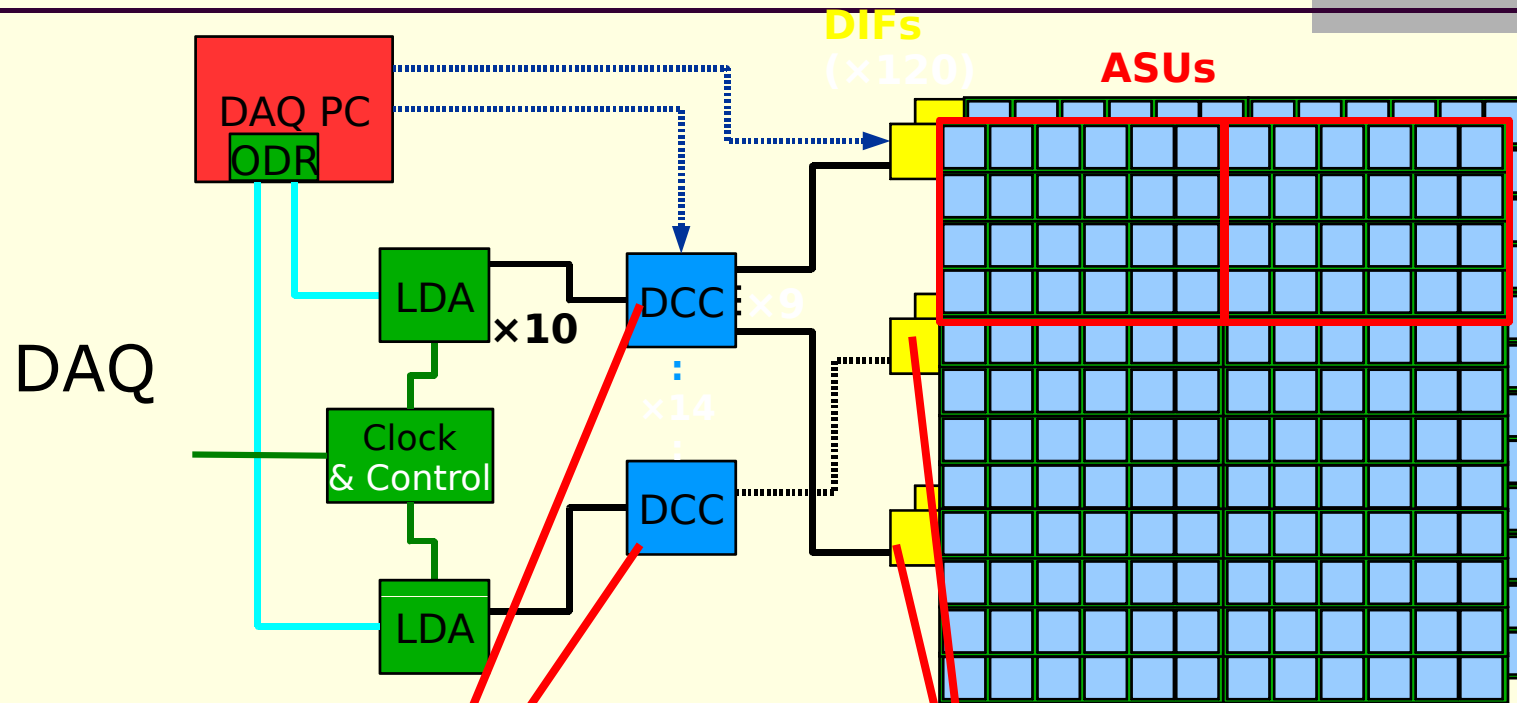

Calibration and Alignment

- Electronics :
 - producing S-curves automatically for each channel
 - Apply automatically gain correction to homogenize response
- Thresholds choice and algorithms to be determined from simulation and confirmed from prototype.
- Detectors Efficiency measured before and after installation using cosmics

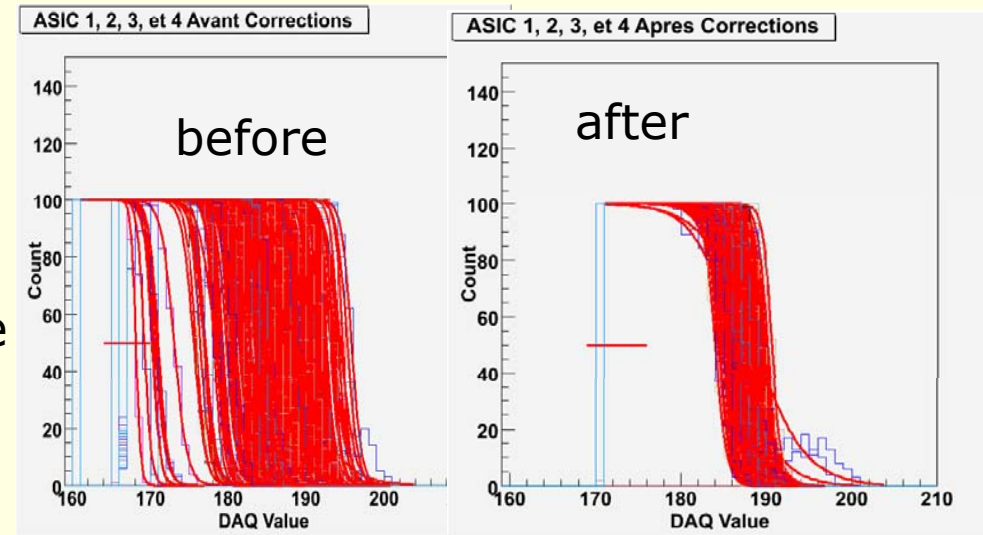

thr1	thr2	thr3	N
yes	no	no	V1
yes	yes	no	V2
yes	yes	yes	V3

Mechanical structure

Motivations :

- No projective cracks neither in Φ nor in θ
- Distance between Barrel and Endcaps is minimized
- Limited deformation

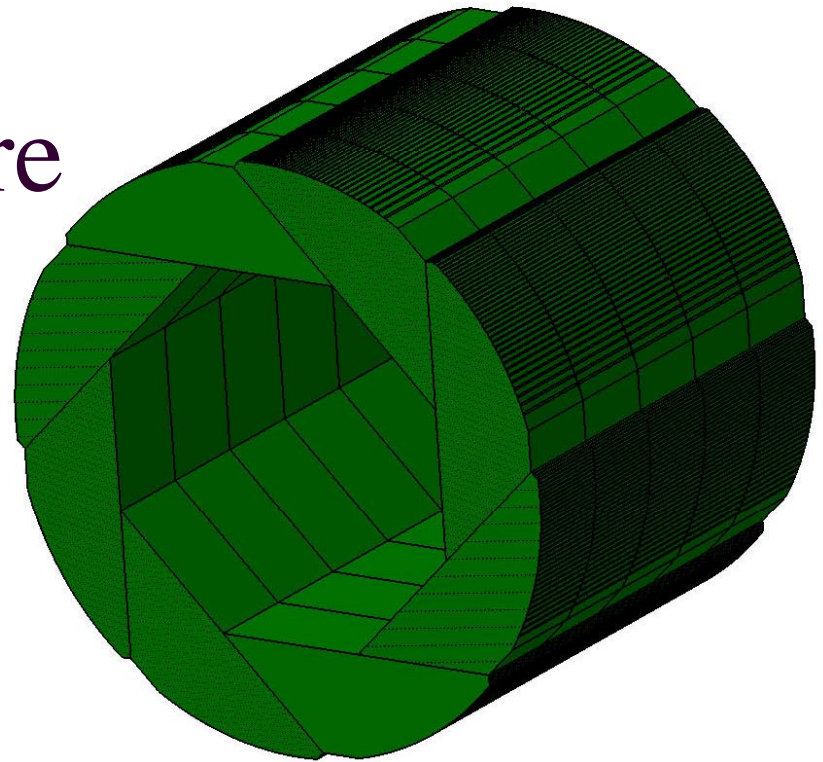

A realistic Endcap mechanical structure is being studied currently

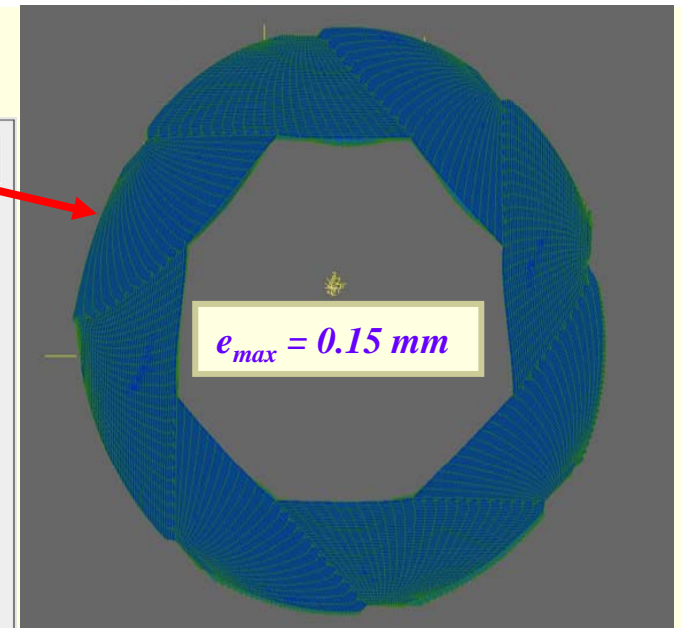
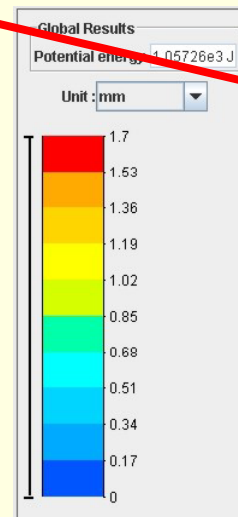

Integration

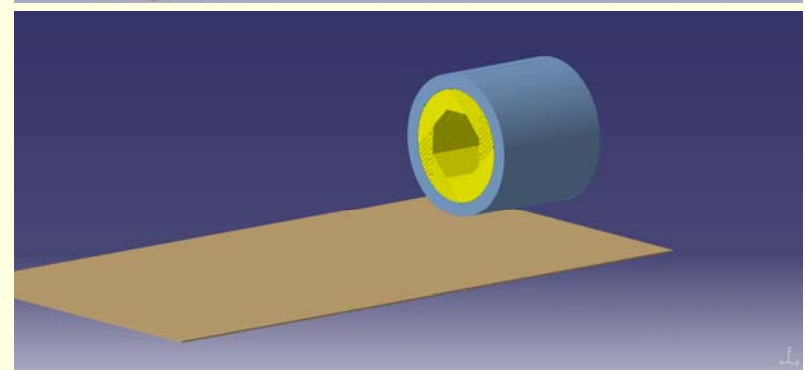
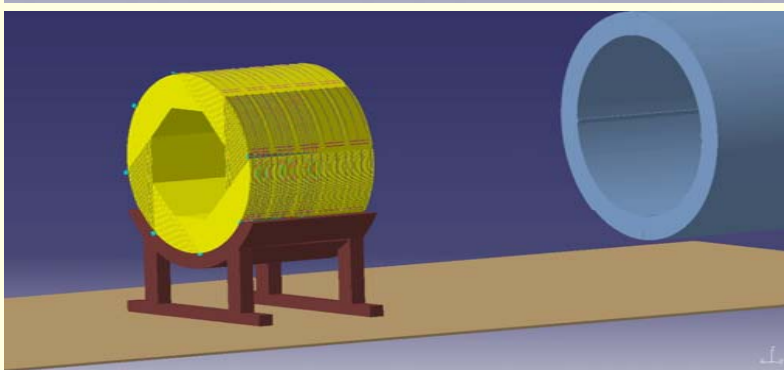
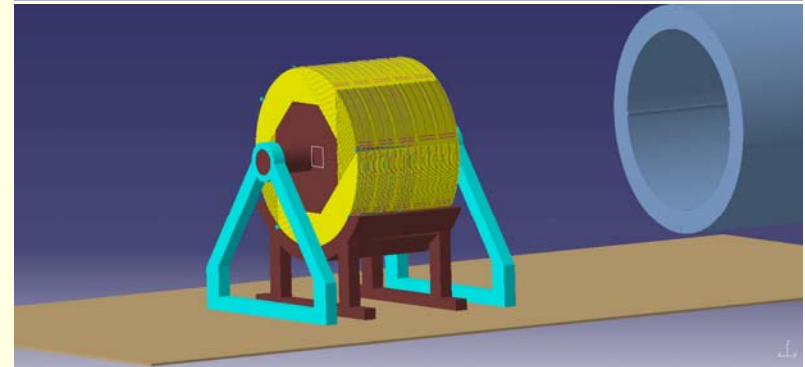
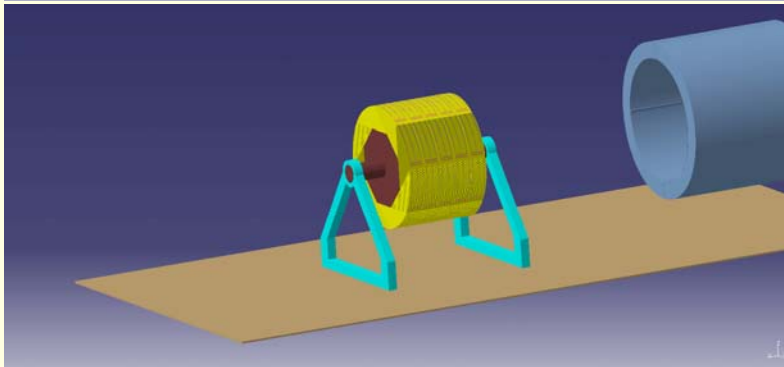
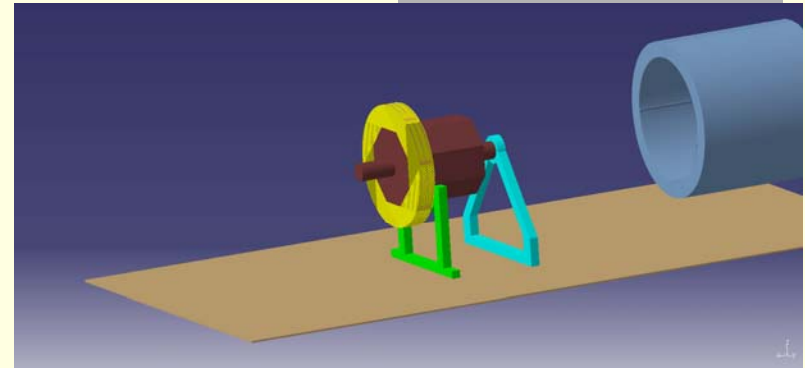
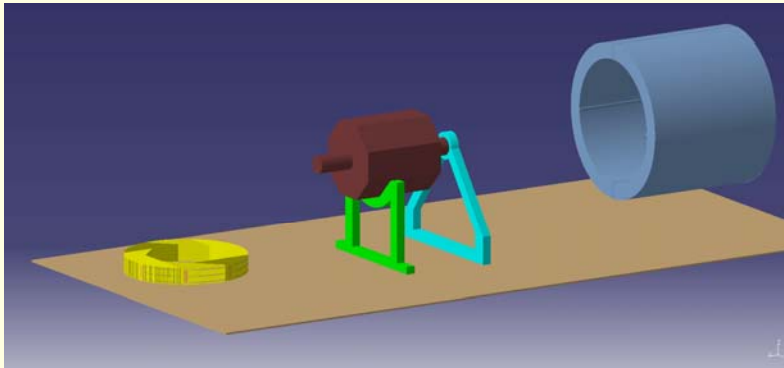

Integration

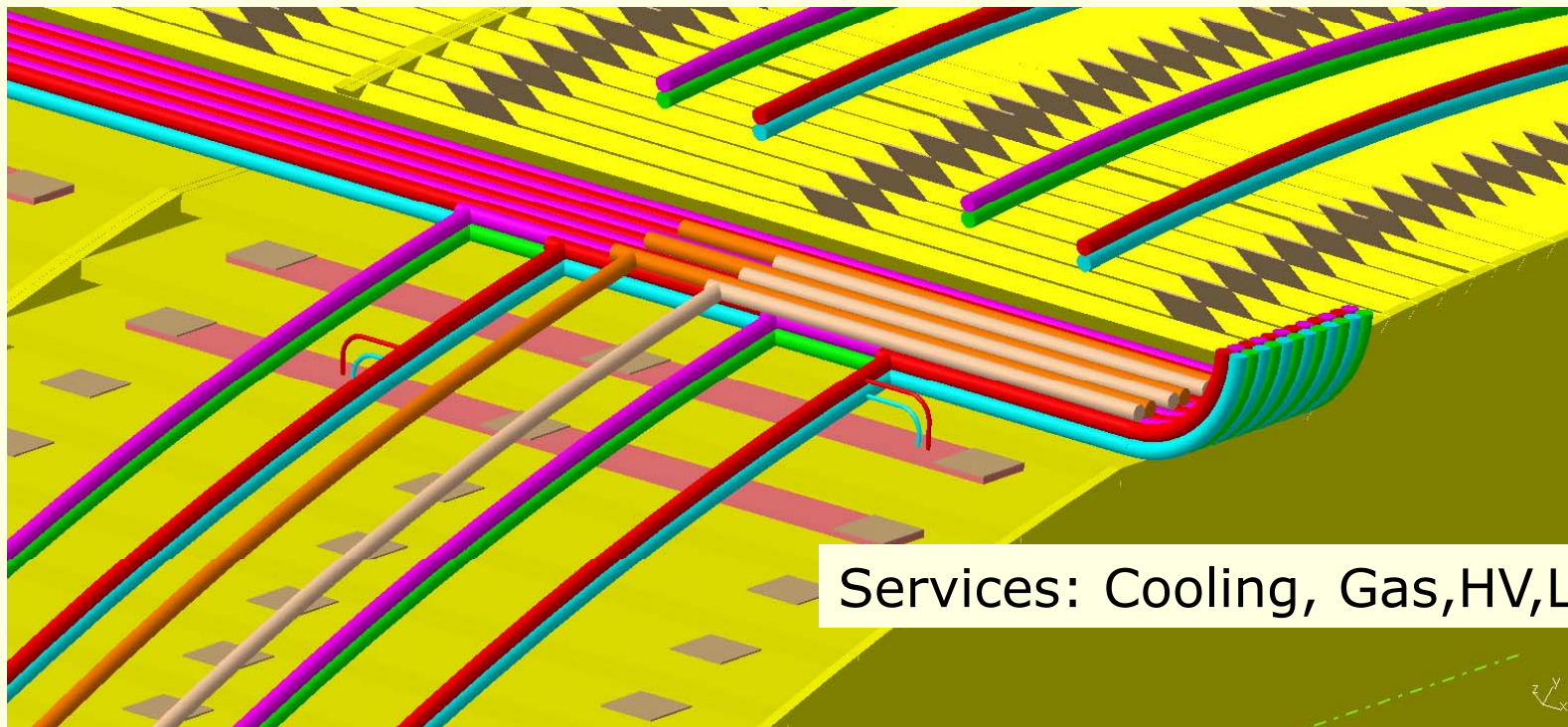
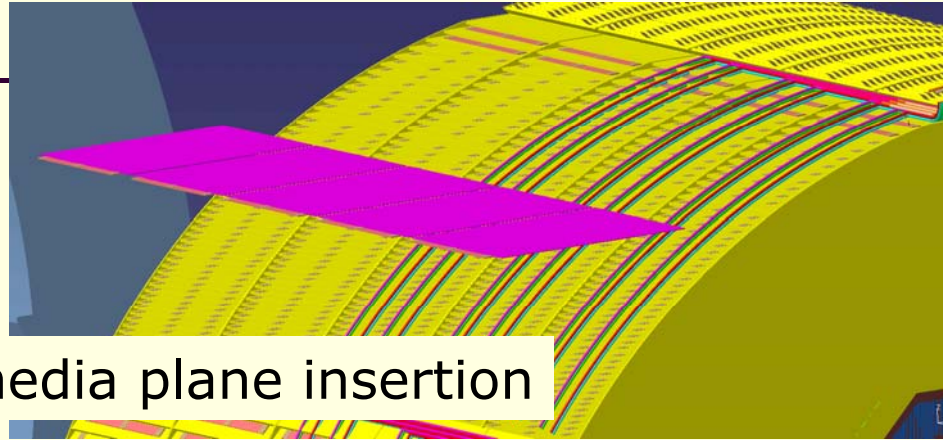

Integration

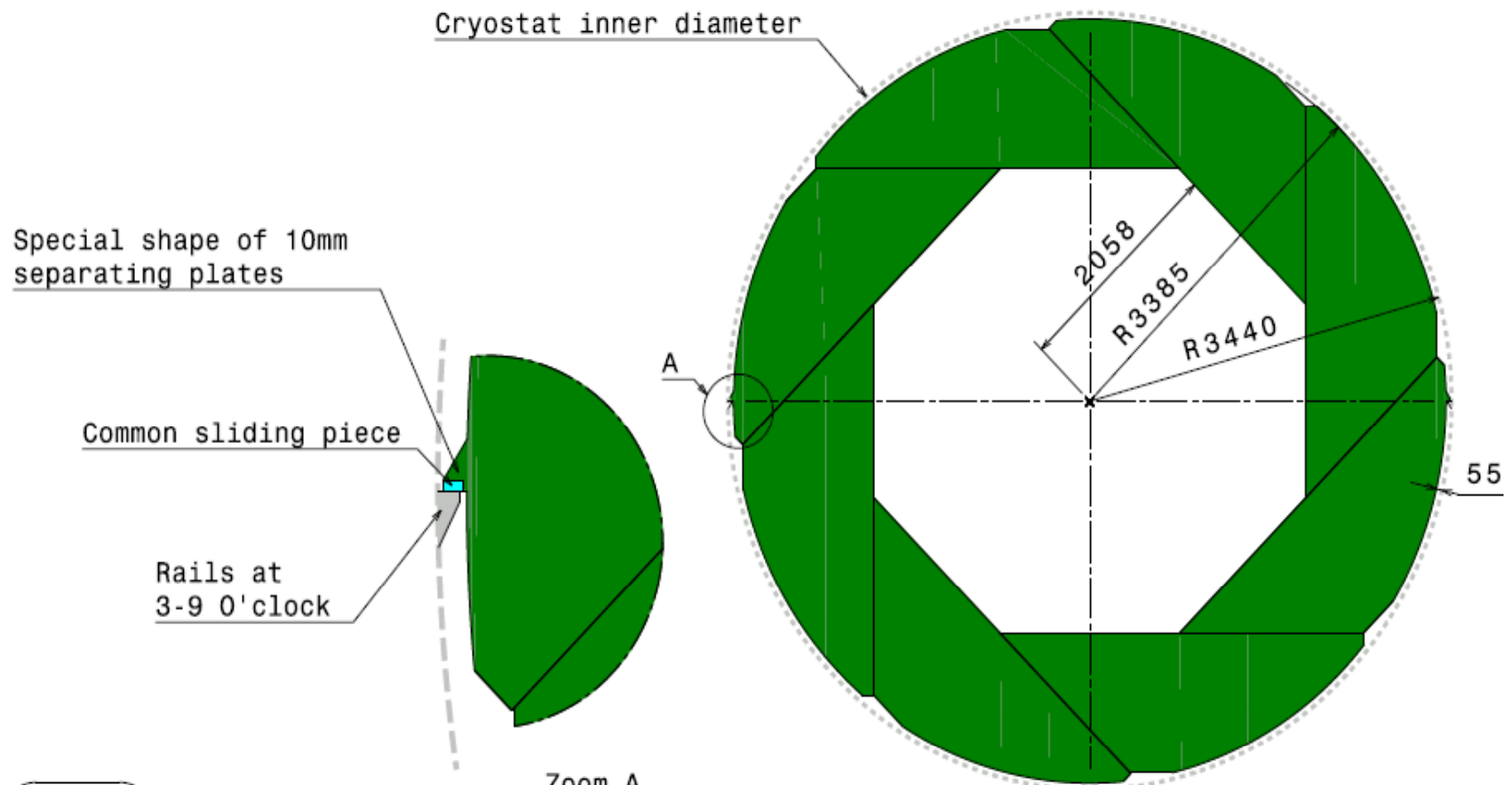

M. Joré
05/01/09
Ech. 1:50

Zoom A
Ech. 1:10

ID Smarteam du 3D :SM1_PRD05890

Simulation

Mokka V06-07:ILD_00Dhcal+ ILD_00fw_Dhcal

Barrel: 48 layers

Sensitive medium : 6 (GRPC)+.5 (tolerance) mm

Absorber thickness: 20 mm

Barrel outer radius : 3381.6 ($R(\text{cryo})_{\text{in}} = 3440$)

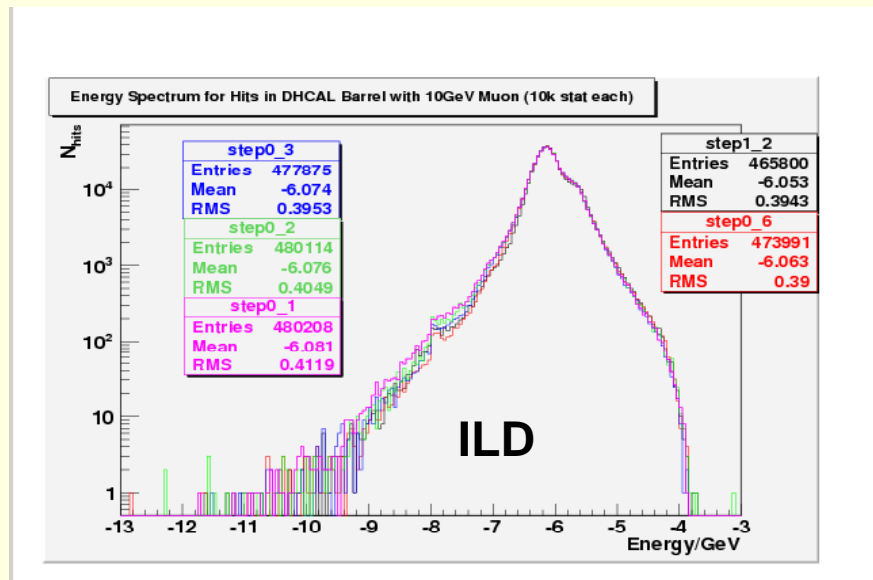

Energy deposit by muons in 1cm² pad

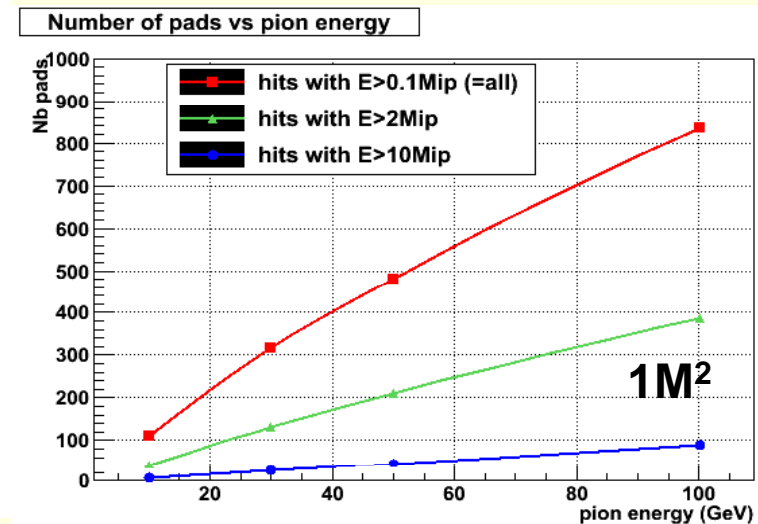

nb of hits% nb of m.i.p

Simulation: Shower leakage

Region 1: mainly Barrel,
NHits Vs Radical distance

A quarter of the DHCAL:

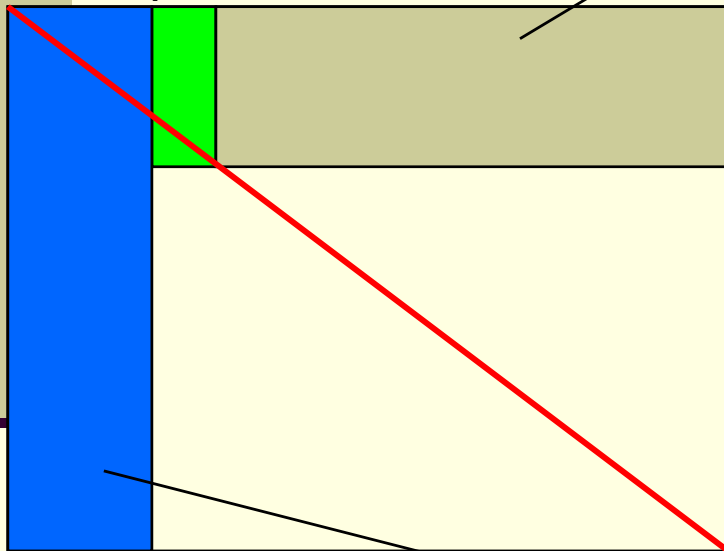

Region 2: mainly EndCap,
NHits Vs Layer Number

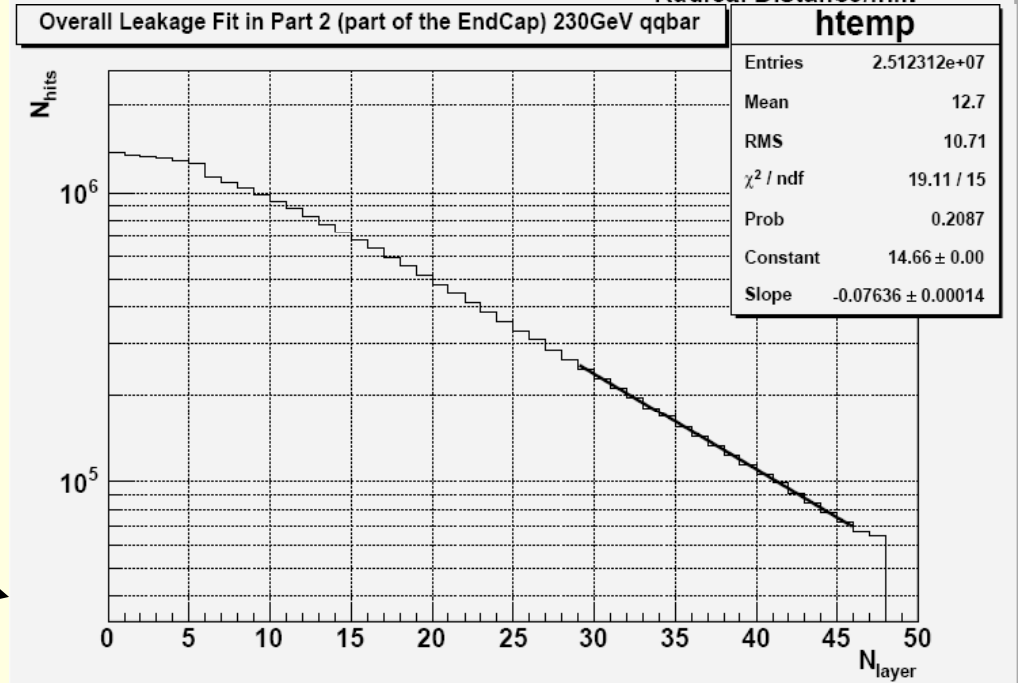
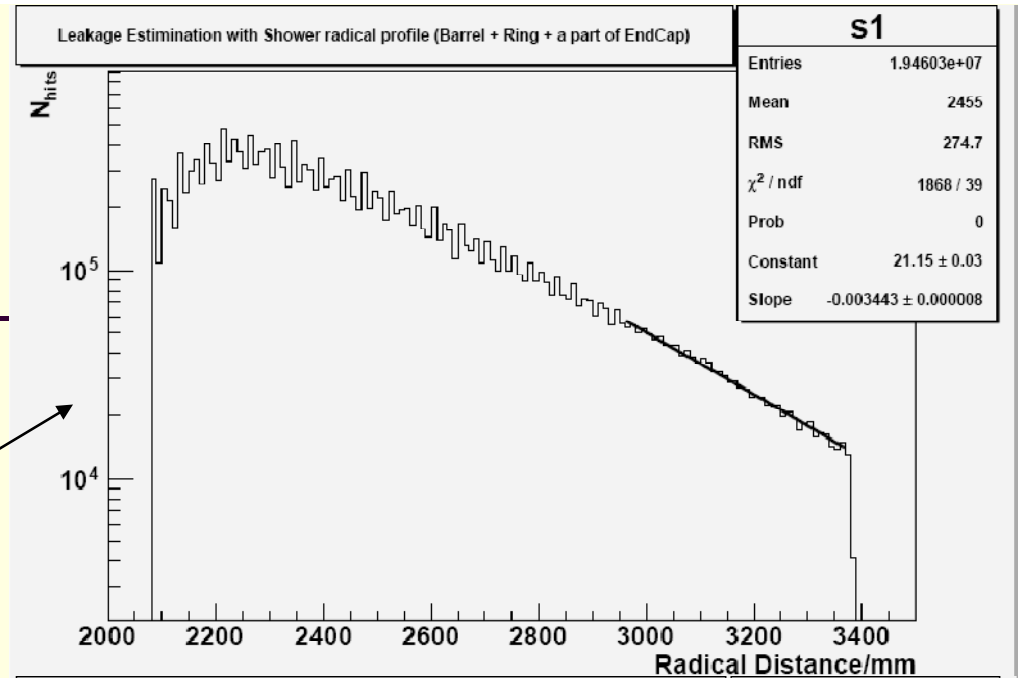

“Optimization”

The Semi-Digital readout with The new MOKKA DHCAL version was included in PANDORA thanks to M.Thomson help.

First shot:

K_{long} inside the barrel
Only one threshold was used

StandardConfig v00-06-00

file mc2008/stdreco_IN.xml
with few changes :

- No Durham jets, no flavor reconstruction.
- Extra Pandora processors.
- LDCCaloDigi changed to NewLDCCaloDigi

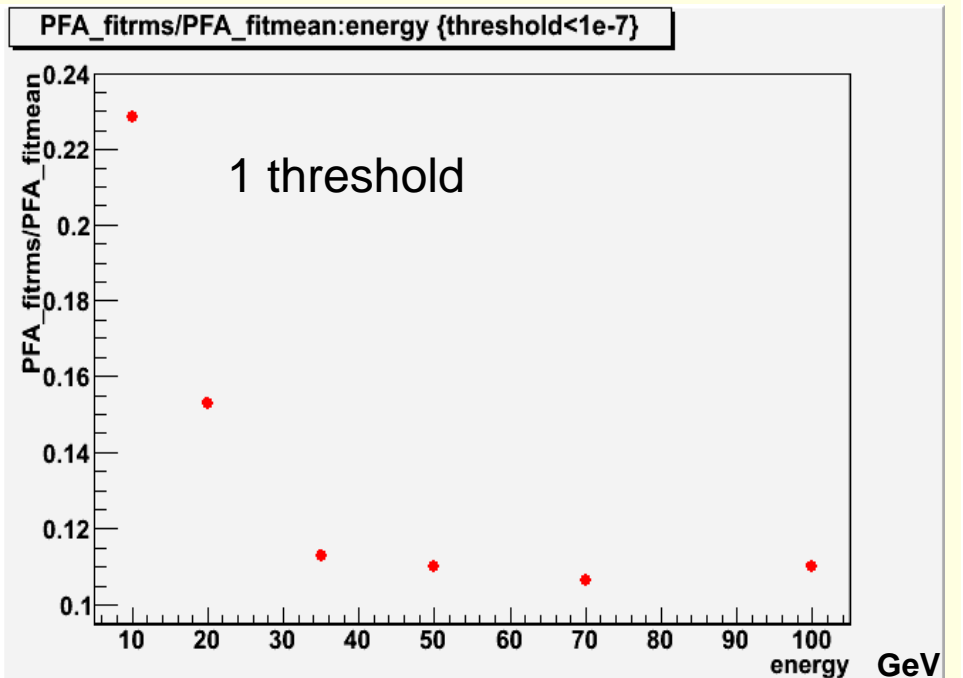
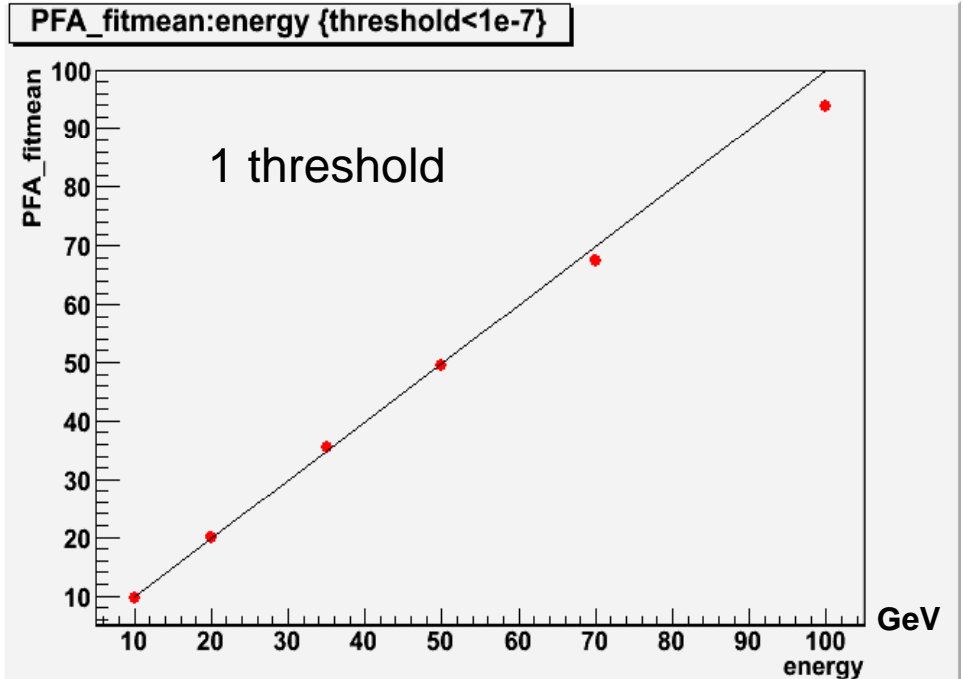

"Optimization"

PYTHIA dijets events

First shot

In barrel :
30.8 % \pm 0.4 % at 91 GeV
Jet resolution = 4.6 %

in barrel :
37.0 % \pm 0.4 % at 200 GeV
Jet resolution = 3.7 %

Semi-digital readout with
3 thresholds is under study

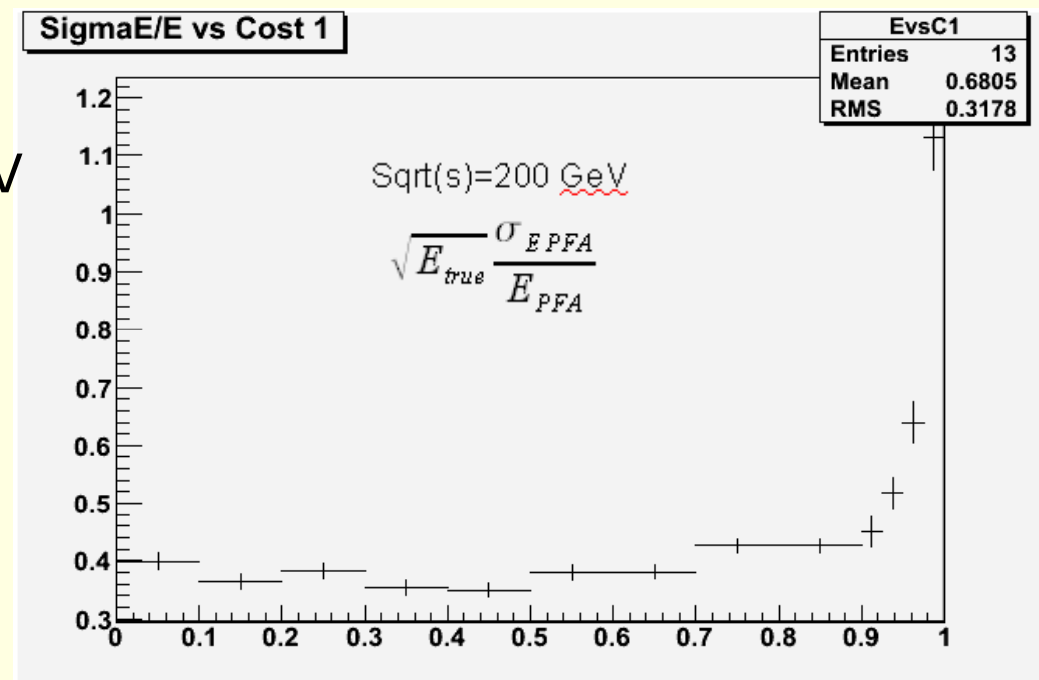
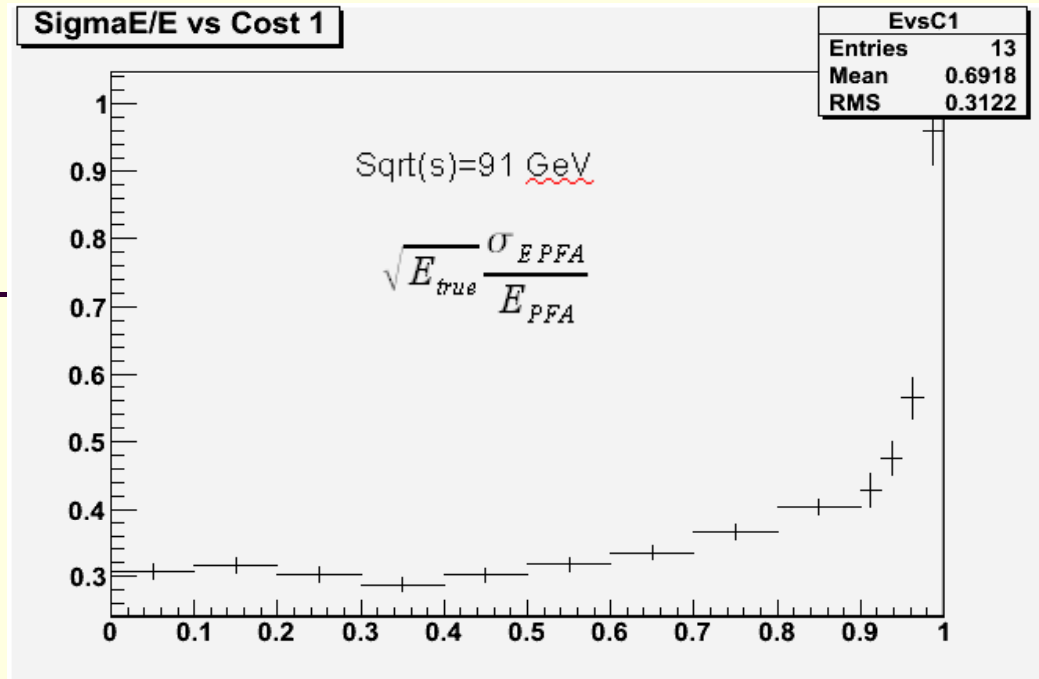

R&D

Technological prototype :
40 plans of 1M² :

16mm s.steel absorber
4mm s.steel support
6mm GRPC

20+6=26mm

The aim is to come as close as possible to
what we would like to have for ILD:

Detector, Electronics, Thresholds choice, DAQ, Mechanical structure,
Gas system

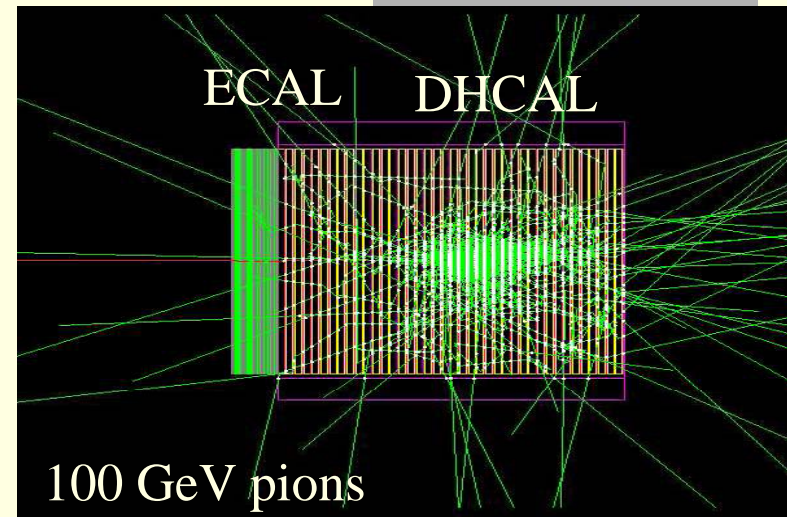

R&D



Different R&D are in advanced phase
Prototype construction expected in 2009-2010

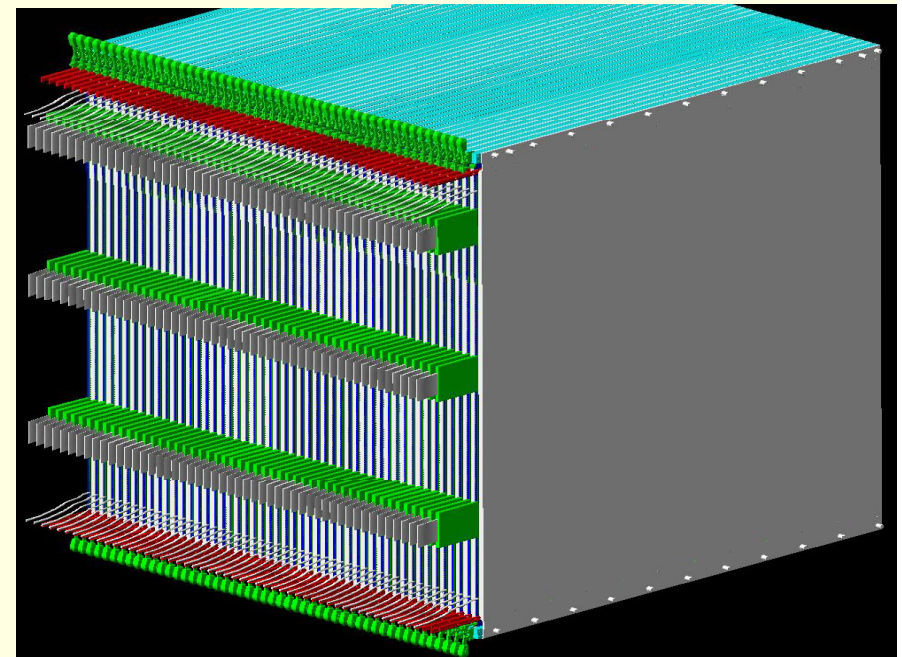
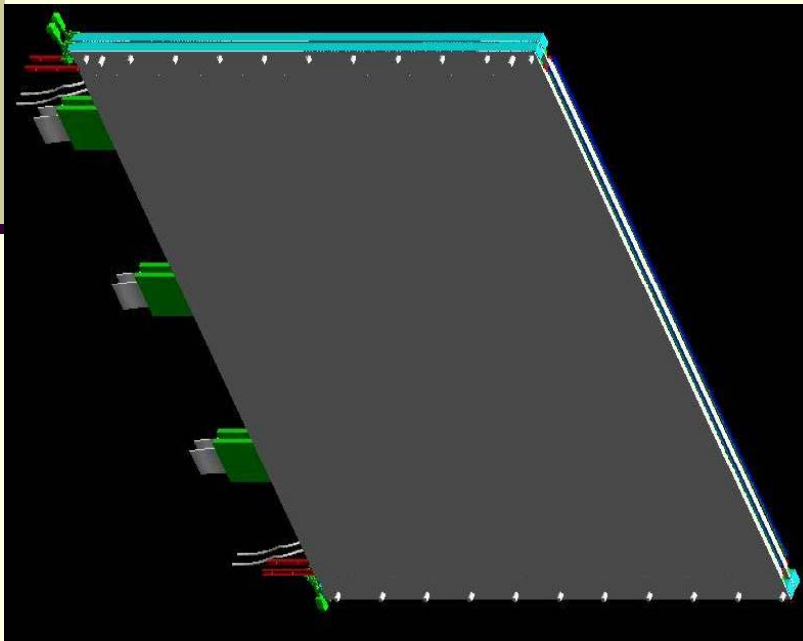

Conclusion

- DHCAL is an excellent option in terms of performance and cost.
- Big efforts were done last three months to be ready for the LOI. Many groups (France, Russia, Spain, Italy, Belgium, China) are contributing .
- First results from the large area detectors fully equipped are encouraging.
- The technological prototype should confirm the performances obtained with mini prototypes.

Backup

Optimization

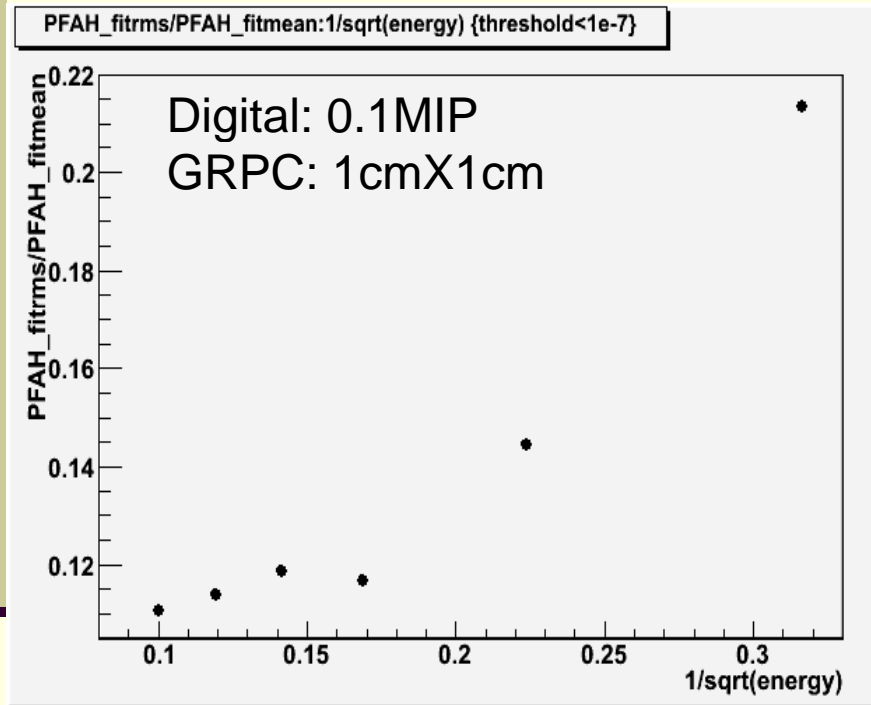

ILD_00

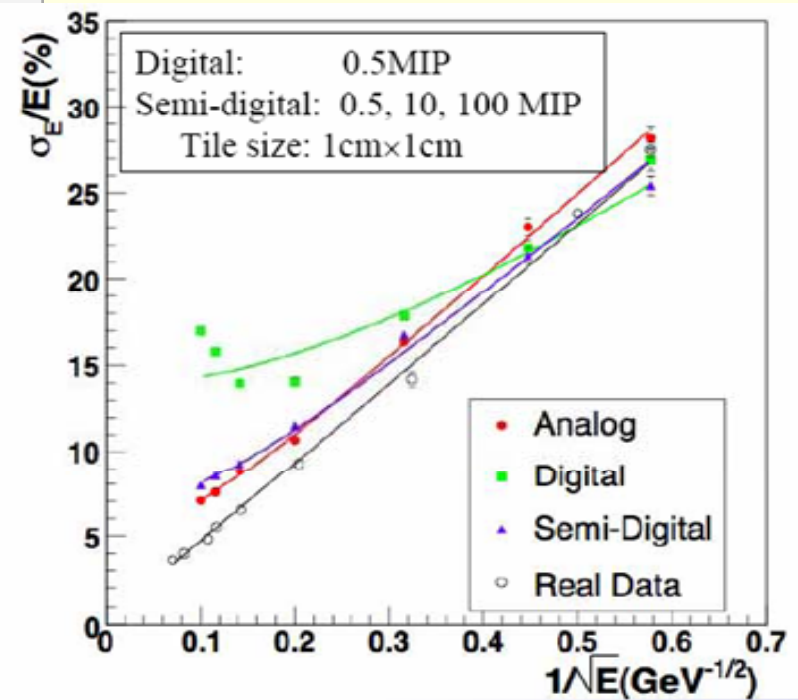

GLD

Optimisation

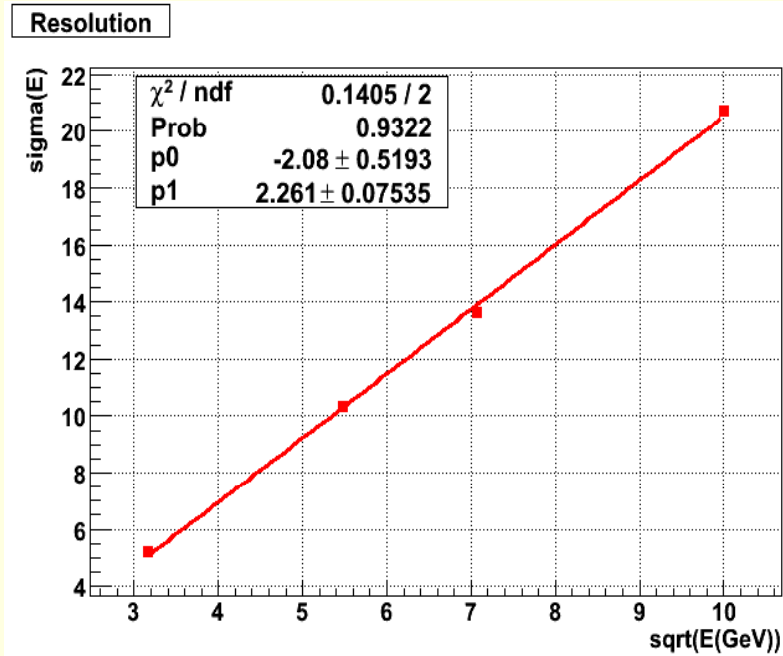
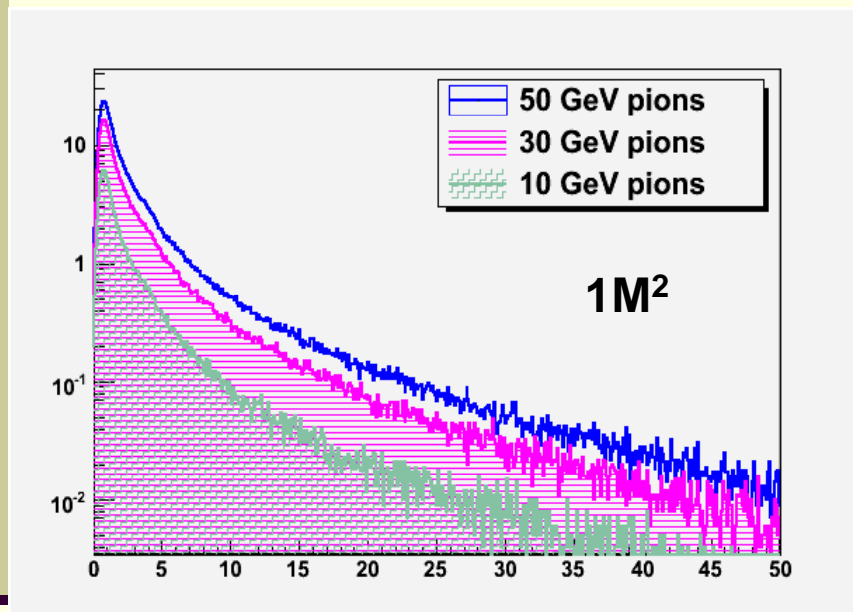

	Barrel	Barrel	EndCap	EndCap	Ring	Ring
	N_{hits}	N_{asic}	N_{hits}	N_{asic}	N_{hits}	N_{asic}
$e^+e^- \rightarrow qq$ GigaZ, 30evt/s	207.6 6.2k/s 0.1/s	124.6 3.7k/s 0.05/s	117.8 3.5k/s 0.1/s	77.8 2.3k/s 0.06/s	6.7 201/s 0.036/s	4.5 135/s 0.02/s
Minimal bias GigaZ, 10evt/s	0.78 7.8/s	0.64 6.4/s	20.2 202/s 0.06/s	17.0 170/s 0.05/s	0.038 0.38/s	0.033 0.33/s
Minimal bias Nominal 660evt/s	1.06 700/s	0.91 600/s	29.7 19.6k/s 4.6/s	25.1 16.6k/s 4/s	0.058 38.3/s	0.05 33/s

Black: expected $N_{\text{hits}}|N_{\text{asic}}$ per event;

Blue: expected $N_{\text{hits}}|N_{\text{asic}}$ per second;

Red: $N_{\text{hits}}|N_{\text{asic}}$ per second on the hottest Asic

Semiconductive glass and ceramics

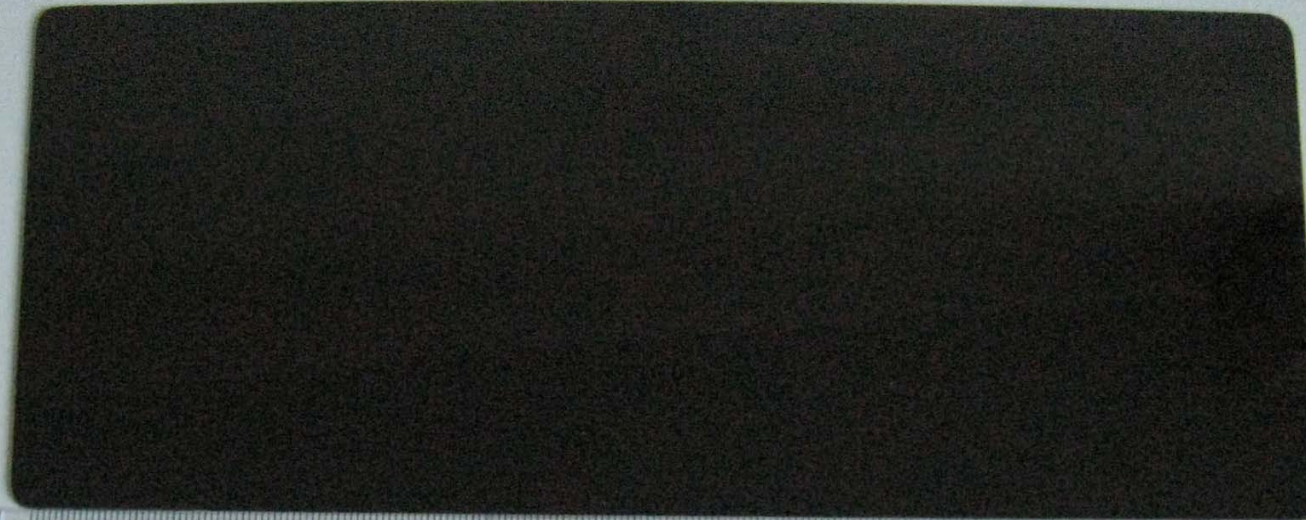

Semiconductive glass

210mm*70mm*0.7mm

$\sim 10^{10} \Omega \cdot \text{cm}$

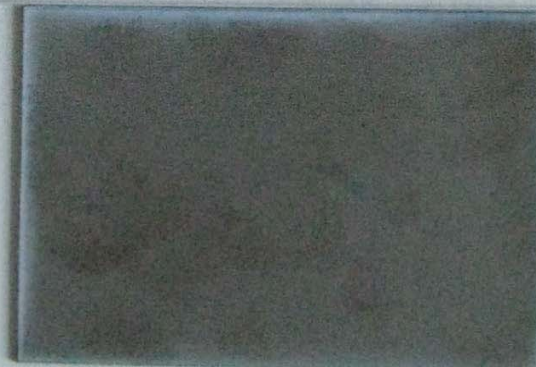

Semiconductive ceramics

80mm*50mm*1mm

$10^6 \sim 10^9 \Omega \cdot \text{cm}$

STAR MRPC workshop @

Outer scene of the workshop

