



XFEL Coupler

Some Comments

Lutz Lilje





- TTF III Coupler
 - has shown full ILC performance
 - has not shown degradation
 - brazed waveguide part ?
 - Is the choice for XFEL and keeps
 - cavity port diameter 40 mm
 - tunability
- Ongoing
 - Industrialisation
 - See slides by S. Prat
 - FNAL 04/2008

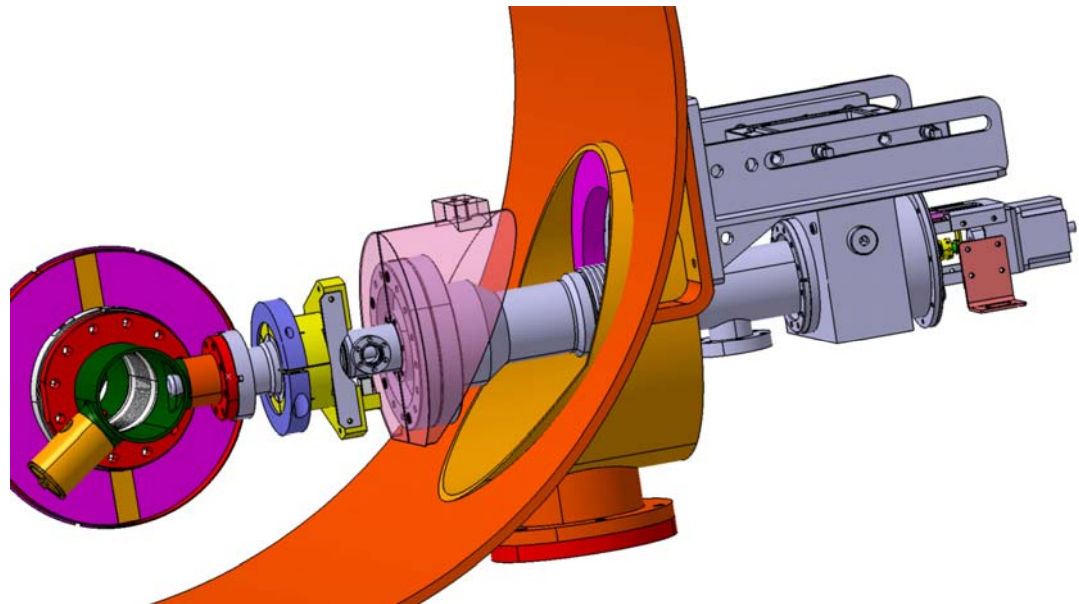

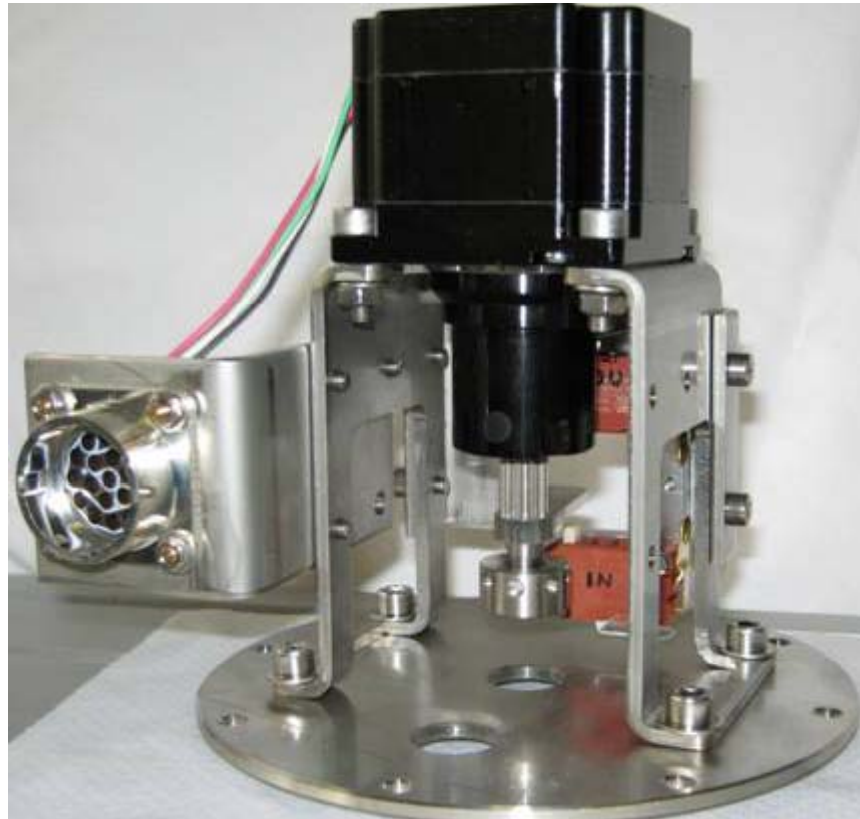

Prototype design for
motorized tuning



Industrial
design



Design to minimize assembly time

(original design: counter flanges + 14 screws)

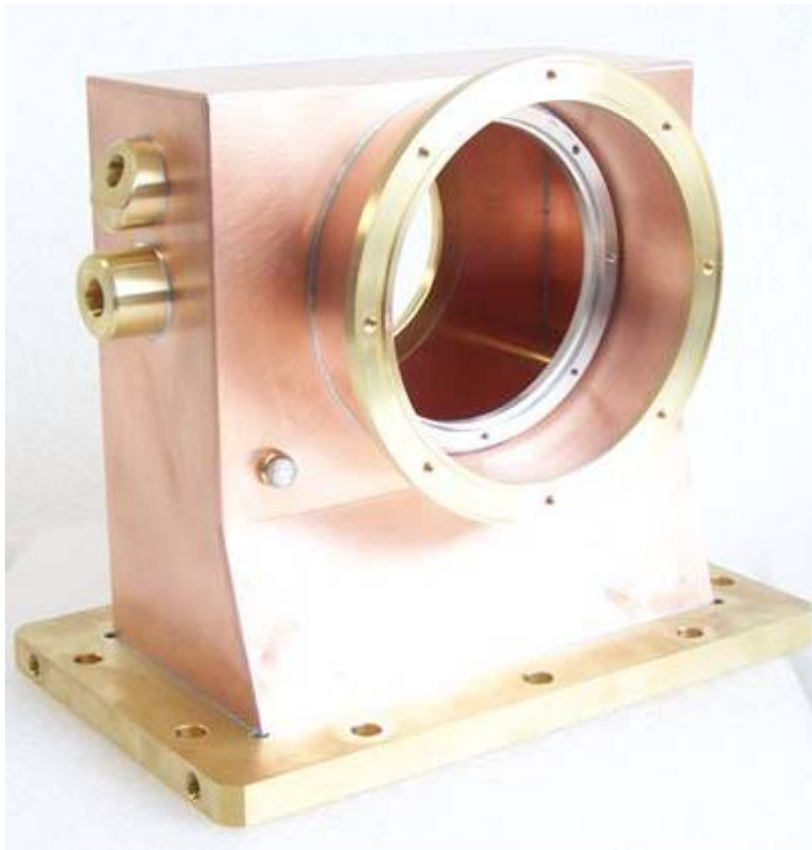

Copper + stainless steel + brass: 13 parts
brazed and soldered

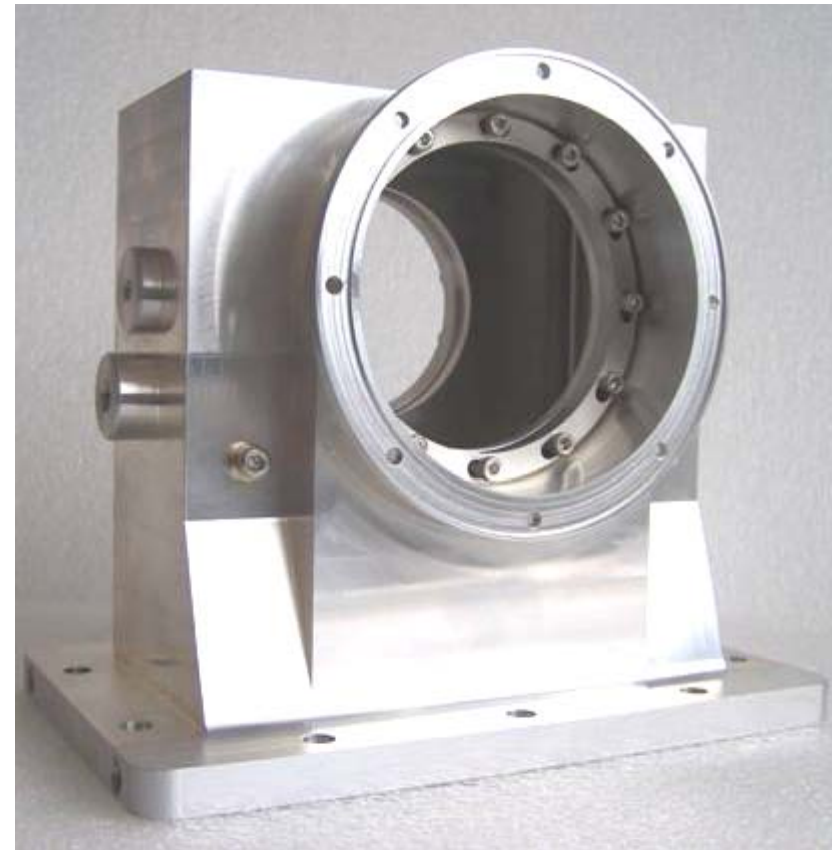

Al alloy: 1 single part
- Prototypes: machined from single block
- Mass production: casting



Headline

- first level
 - second level
 - ➔ third level

Headline

Texttext texttext
texttext texttext
texttext texttext

Keyword

1. Keyword
2. Keyword

- keyword
- keyword

Result Headline

- result text
- result text

Result headline

Result text, result text,
result text

Result headline

- result text
- result text
- result text