

International Linear Collider at Fermilab

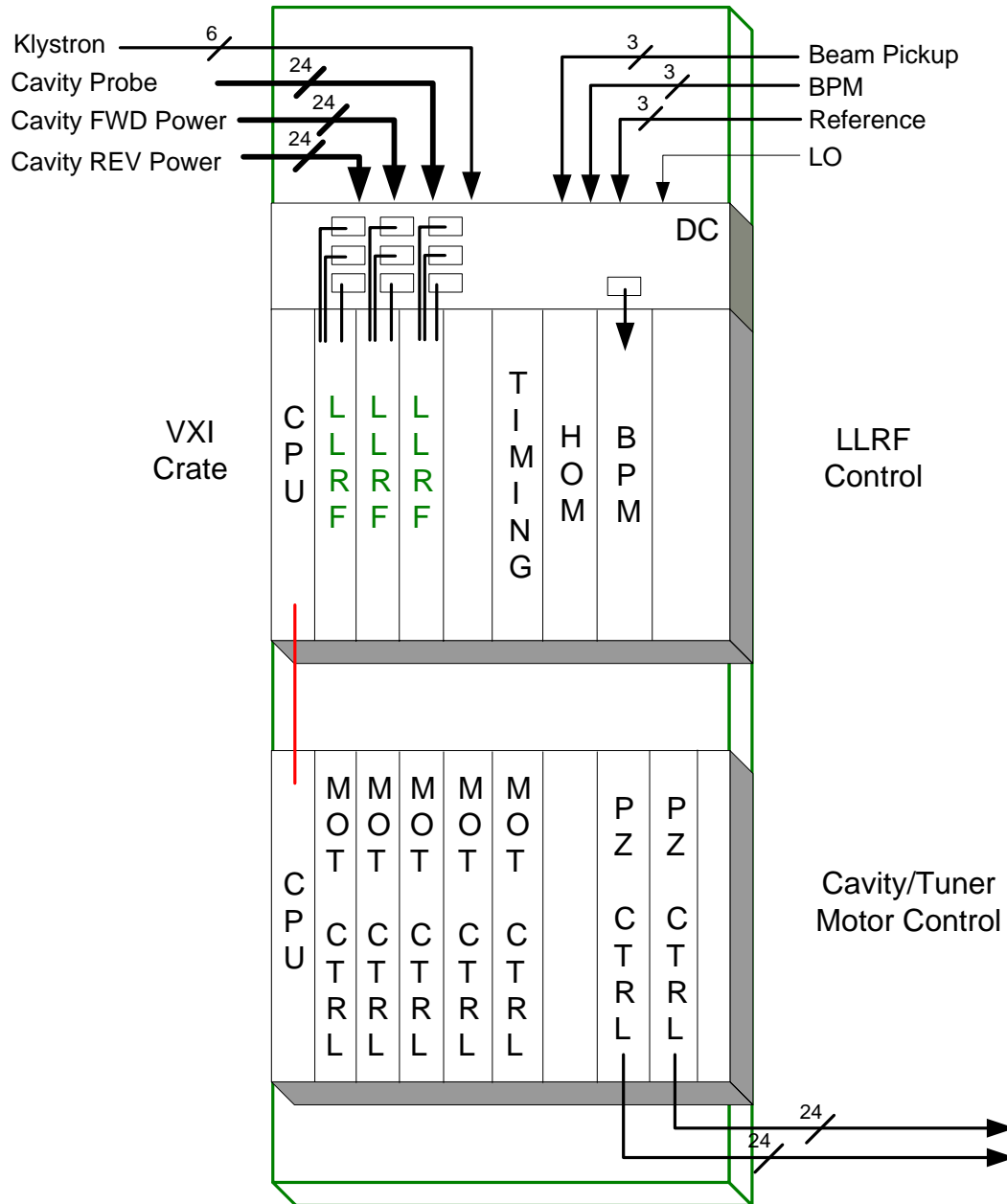

LLRF/Instrumentation Rack

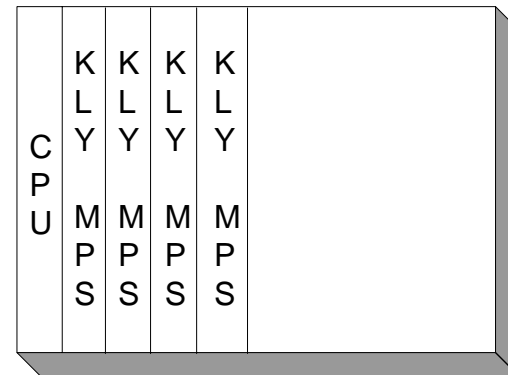

International Linear Collider at Fermilab

Timing and Synchronization

Inter-system Feedback Network/Bus

MPS Network/Bus

RT Control Network

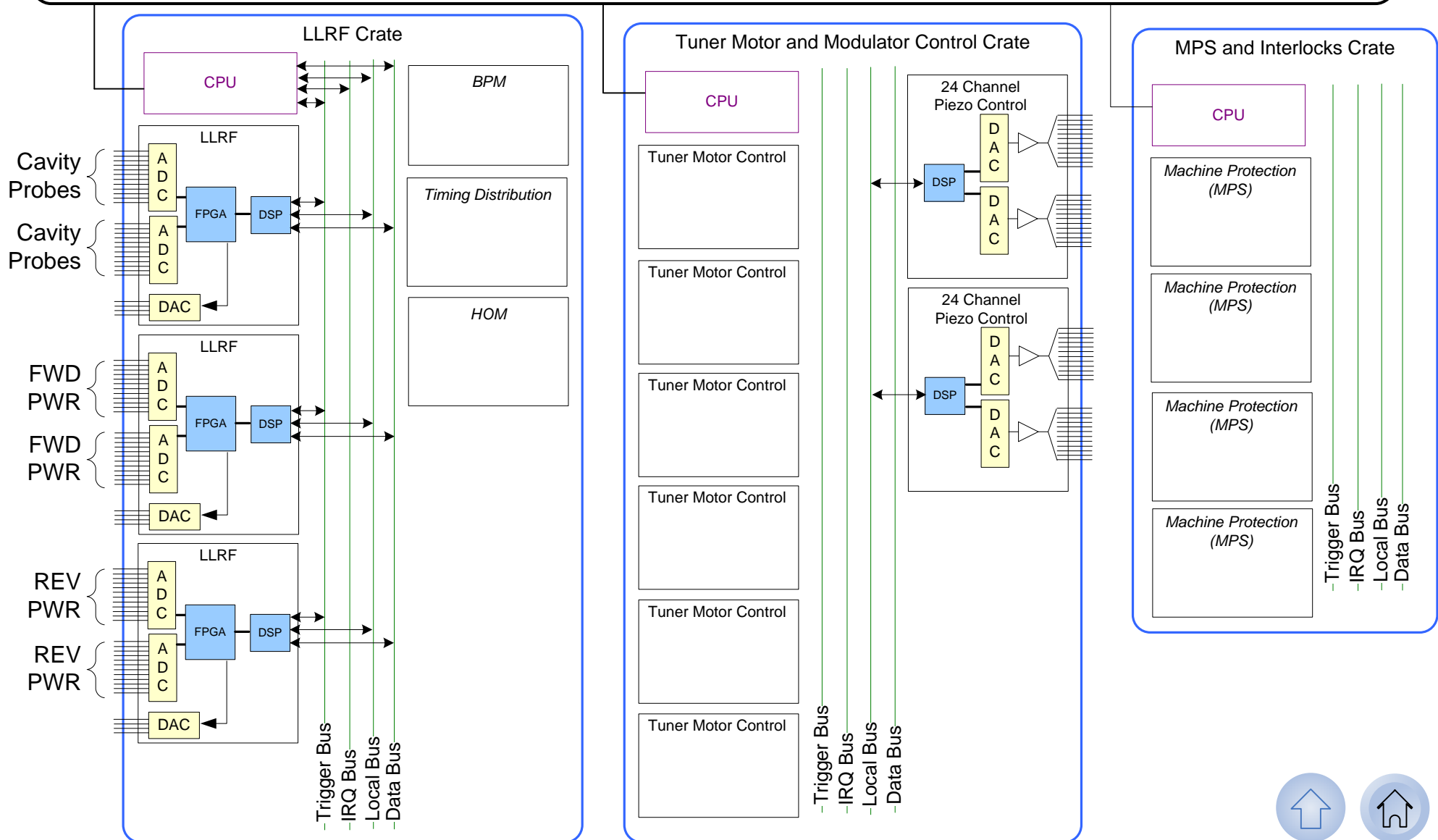

International Linear Collider at Fermilab

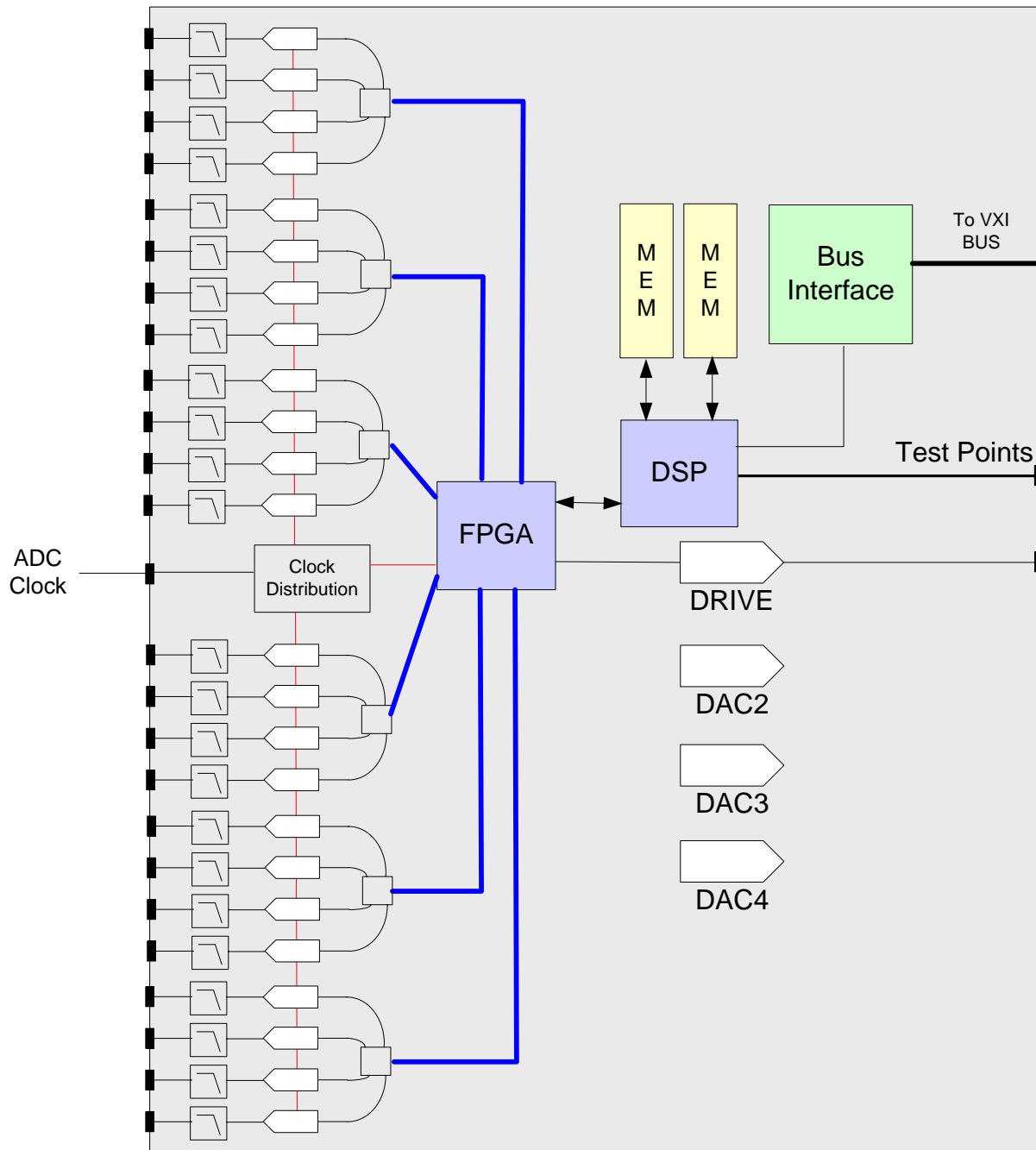

Component Pricing

1 4 Channel, 12 bit, 65 MSPS ADC (AD9229) X 8	\$256.00
1 Altera Stratix FPGA	\$350.00
1 Tiger SHARC 500 MHz Floating Point DSP	\$250.00
1 Channel 65 MSPS DAC outputs (AD6644) X 4	\$160.00
1 Altera Cyclone FPGA for bus interface	\$150.00
Board Fabrication	\$350.00
Board Stuffing	\$250.00
VXI Kit	\$200.00
Front Pannel connectors X 4	\$ 80.00

Cost per board

\$2050.00

