

# Proposal for a LCIO format for the DHCALs

Vincent Boudry  
Rémi Cornat  
David Decotigny  
LLR  
Gérald Grenier  
Robert Kieffer  
IPNL

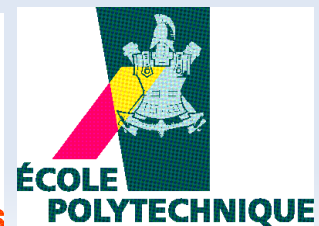

***EUDET annual meeting  
U. of Geneva  
19/10/2009***



# Raw data

- **Starting point:** store the EUDET DAQ2 raw data originating from a DHCAL using **ROC chips** providing **frame** ( $\neq$  ROC  $\leftrightarrow$   $\neq$  frame length)
- Keep the frame order for each chip and DIF (and other intermediates cards)  $\rightarrow$  counters, error & malfunctions tagging, full history
  - ▶ Train by train
  - ▶ 1 train  $\equiv$  a complete set of auto-triggered frames from one ASIC, readout on an external signal [trigger, DAQ stop, RAM full]
  - ▶ 2 Acq modes

- ♦ ILC like

- Trig = Spill start

- ♦ Triggered

- Ext. Trig
- RAM full manag<sup>t</sup>

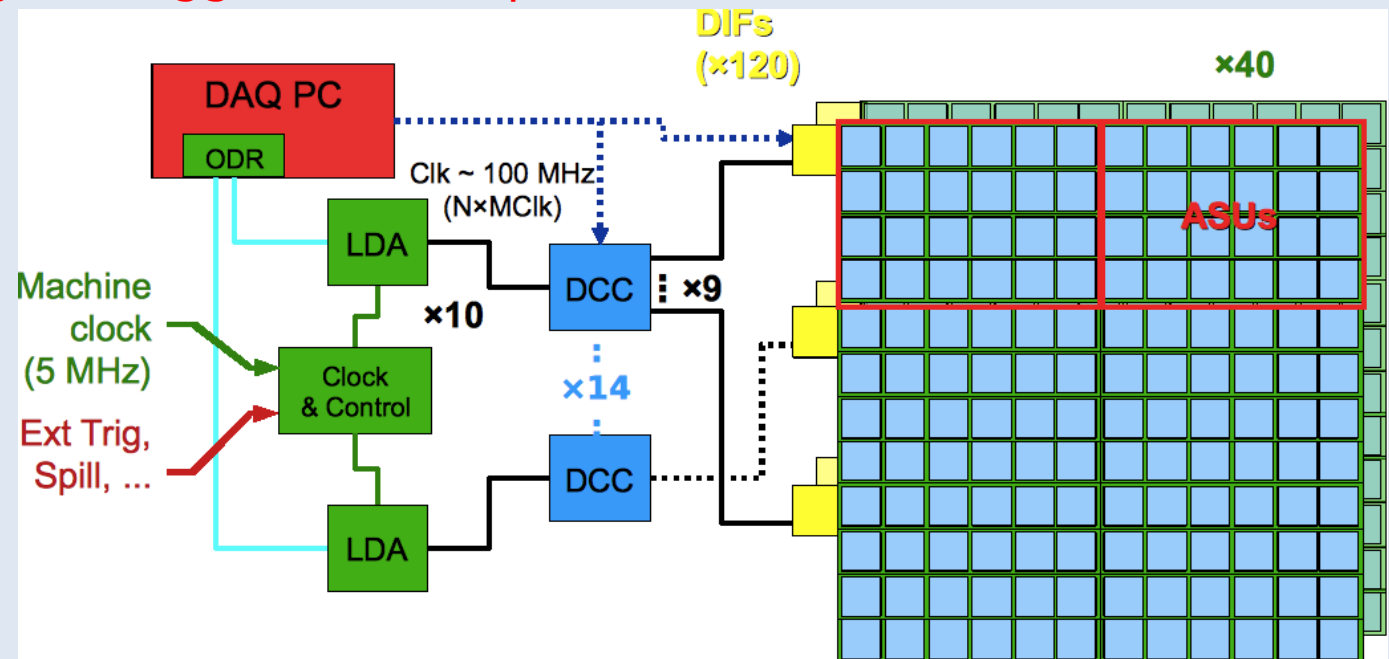

# RAW data proposal (suitable for ROCs)

V. Boudry, R. Cornat,  
D. Decotigny

LCIO format (source):  
[https://svn.in2p3.fr/calice/  
online-sw/trunk/daq/  
reassembler/  
lcio\\_dump.hpp?view=markup](https://svn.in2p3.fr/calice/online-sw/trunk/daq/reassembler/lcio_dump.hpp?view=markup)

Physical address  
( $\supset$  redundancy)

Event  
Counter/Tagging

Event Timing

**Compacity**  
**vs**  
**Redundancy (debugging)**

```
namespace IO
{
  class LCWriter;
};
/**
```

```
*
* Run Header:
* - RunNumber: user-specified
* - DetectorName: user-specified
* - Description: user-specified
* - ActiveSubdetectors: [ "DIF_rawdata" ]
*
```

```
* Event:
* - DetectorName <- runHdr::DetectorName
* - RunNumber <- runHdr::RunNumber
* - EventNumber <- ROEventId::toUnsigned()
* - TimeStamp: default
* - Weight: default
* - LCCollection "rawdata_DIF:str(DIF_id)":
*   + param "id_ODR" (unsigned): from raw event
*   + param "id_LDA" (u32b)
*   + param "id_LDA_diflink" (unsigned)
*   + param "id_DIF" (unsigned)
*   + param "TrainNumber" (unsigned) // since DAQ start
*   + param "BC_DIF" (unsigned) // since RUN start
*   + param "DeltaCounter" (unsigned) // 40 MHz counter
*   + param optional extra DIF info (type, temp, adc) ???
*   + elt[0]: LCGenericObject
*     + int[0]: id_roc_chain
*     + int[1]: id_roc
*     + int[2]: index_in_dif_dump (starts at 0)
*     + int[3]: chipType
*     + int[4]: acqMode
*     + For HR2 chips:
*       + int[5]: nframes (< 128)
*       + int[6 + i*5]: bcid for frame i (i in [0, nframes])
*       + int[7 and 8 + i*5]: t0 vector (msb 7=t0_63, lsb 8=t0_0)
*       + int[9 and 10 + i*5]: t1 vector (msb 9=t0_63, lsb 10=t0_0)
*       + int[11 + i *5...]: additional data ??
*     + elt[1]: other LCGenericObject (ROC event)
*     ...
* - other LCCollection "rawdata_DIF:str(DIF_id)":
*   ....
```

RAW Data "in the tubes" format:

[https://svn.in2p3.fr/calice/online-sw/trunk/daq/  
calice\\_packets/calice\\_raw\\_formats.h?view=markup](https://svn.in2p3.fr/calice/online-sw/trunk/daq/calice_packets/calice_raw_formats.h?view=markup)

# LCIO format for reconstructed DHCAL Header & DIF part (proposal v0.01)

back of envelop discussion  
V. Boudry, G. Grenier, R. Kieffer  
+ Lei Xia (US DHCAL)

```
EVENT::LCEvent
{
    int  _runNumber;           //
    int  _eventNumber;        // Global Trig Count == # evt
    EVENT::long64 _timeStamp; // Mean timestamp from Hit/DIF
                                // TB: Large BC
                                // For ILC: Large BC since run start.
    std::string  _detectorName; // Detector version ??
    LCCollectionMap  _colMap; // List of collections
    std::vector< std::string > _colNames; // Name of collections
    LCParametersImpl  _params; //
    LCCollectionSet  _notOwned; //
}

EVENT::LCGenericObject
{
// ->DIF Collection
// - int DIF_ID+Module_ID           // DIF_ID (48-144 ==> 7-8b)
//                                     // + Module_ID (40 barrel + 24 Endcap ==> 6b)
// - int ATC                         // delta GTC / DTC
// - int DTC                         // Diff Trig Counter == #evt vu par la DIF
// ( - float TimeDiff                // Time2Previous event )
// - int LargeBC                     // BC from run start.(32b)
}
```

# LCIO format for reconstructed DHCAL Calorimeter hits (proposal v0.01)

EVENT::RawCalorimeterHit

```
{
  int  _cellID0;           // Chan (64 ==> 6b)
                             // + Asic (max 420 ==> 9-10b)
                             // + Dif_Id (48-144 ==> 7-8b)
                             // + Module_Id (40 Barrel + 24 Endcap ==> 6b)
                             // == 28-30b (remain 2-4b) [6+6+7 == 19b in TB]
  int  _cellID1;           // Time2Previous (in BC) ==> 24b (remain 8b) (CHBIT_ID1 must be set)
  int  _amplitude;         // 3 Thr ==> 2b (remains 30)
  int  _timeStamp;         // Rec Time on 32b wrt (Spill start | Ext. Trigger)
}
```

ILD and TB compatible

EVENT::CalorimeterHit

// Reconstructed Hits

```
{
  int  _cellID0;           // Idem RAW
  int  _cellID1;           // Idem RAW (CHBIT_ID1 must be set)
  float _energy;           // Rec Energy
  float _time;             // time from ref (in ns).(LCIO::RCHBIT_TIME must be set)
  (float _position [3]);   // Position (unit not fixed) (LCIO.CHBIT_LONG must be set)
  int  _type;              // Deposit type (mip, EM, noise, ...)
  EVENT::LCObject * _rawHit; // Link to RAW hit
}
```

One also needs the mapping functions:     int[3] GetIJK(cellID);  
  float[3] GetXYZ(cellID);

Error on Energy => to be recalculated, or integrated to energy.

# Comments ?

- Very first draft
  - ▶ to be discussed...
  - ▶ being implemented for SDHCAL offline storage
- to be implemented for the DAQ2
  - ▶ Needs to be finalised before data taking
  - ▶ Once validated → modification of LCIO ?
- Additional point for any DAQ:
  - ▶ Improvement of online writing
    - ◆ Experience from EUDAQ:
      - “Difficulty for keeping a LCIO file open for a long time”
  - ▶ Flush + easy crash recovery (?)