



Magnetic System Overview Solenoid and DID

Olivier Delferrière, François Kircher

Centre d'Etudes de Saclay (CEA-Saclay)





Introduction

1. Version « ILD-V5 Saclay » for the Solenoid configuration
Optimized solution without anti-DID
Homogeneous field in the TPC volume
2. Introduction of the Anti-DID
Anti-DID coil design – *Brett Parker design*
Air-coil and anti-DID in ILD design comparison
TPC Field Homogeneity study: Correction coils and anti DID

Conclusions and remarks



- New detector concept for ILC:
ILD = mixture of GLD and LDC
- Saclay ILD electromagnetic simulations by :
O. Delferrière, F. Kircher
- ILD V5 – Saclay version = last version before LOI
- 2D axisymmetric electromagnetic simulations (OPERA-2D[©]) for :
 - 1) Stray field optimization including all gaps
 - 2) TPC homogeneity without anti-DID

BARREL YOKE

12-fold shape. It is longitudinally split into three parts. In the radial direction, the inner part of the yoke is made of 10 iron plates, with a space of 40 mm between each to house the muon detectors. 3 external thick plates, each 560 mm thick with 40 mm space in between, make up the total iron thickness.

END CAP YOKE

12-fold shape, similar split structure, with 10 iron plates in the inner part, with a space of 40 mm between each to house the muon detectors, and 2 external thick plates, each 560 mm thick, to make up the total iron thickness.

FIELD SHAPING PLATE

A 100 mm thick field shaping plate (FSP) will be added inside each end cap to improve the field homogeneity.

- **3D electromagnetic simulation for TPC homogeneity with anti-DID (OPERA-3D/TOSCA[©]) – cylindrical geometry assumed**
Simplified geometry without all the 40 mm internal gaps for muon detectors
Only the main “mechanical gaps”



saclay

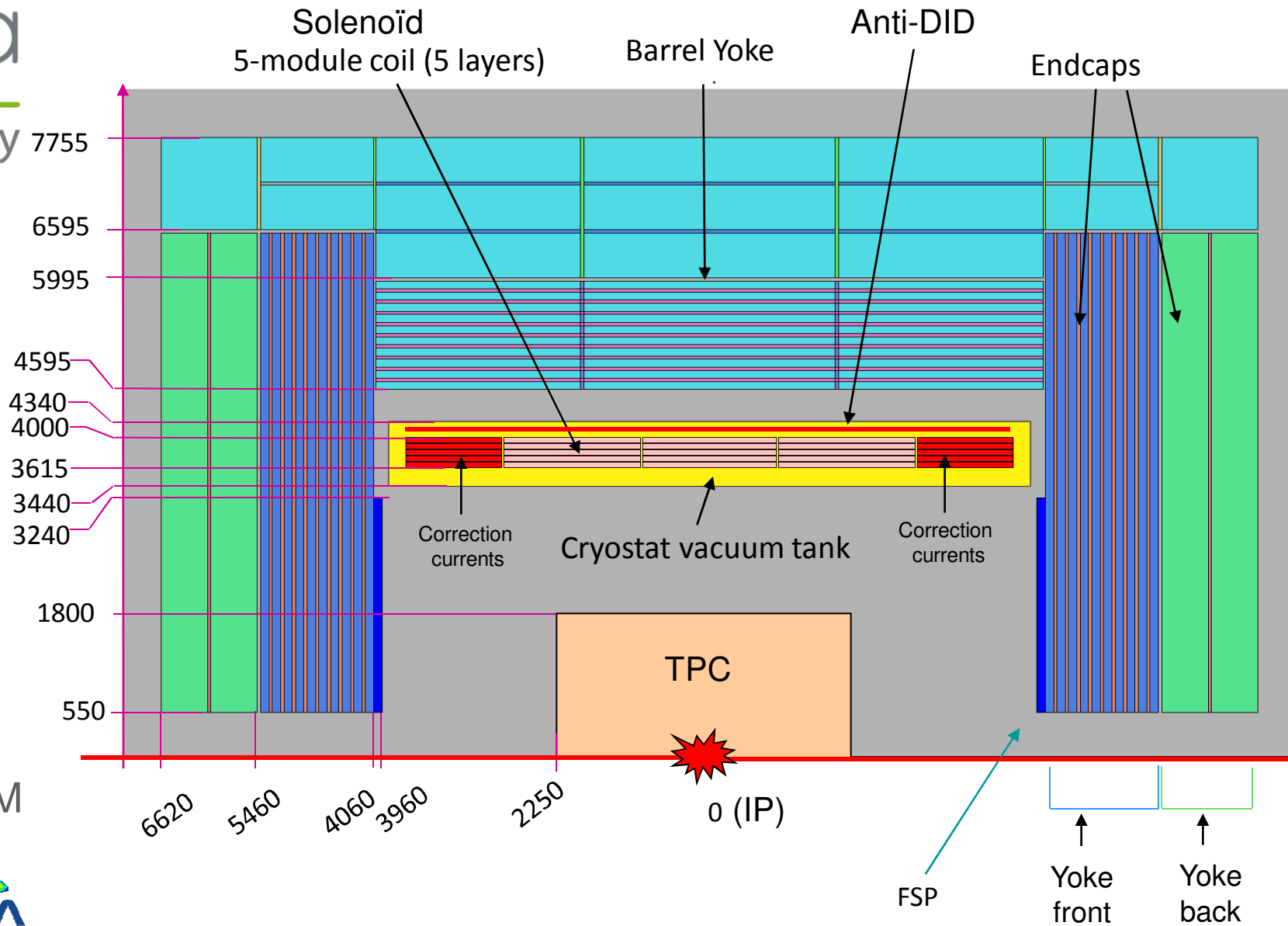

SACM

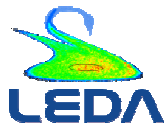



ILD V5 Saclay

SACM



Central field (T)	3.5 (500 GeV op.)	4.0 (design)
Maximum field on conductor (T)	4.82	5.50
Stored energy (GJ)	2.1	2.7
Stored energy per unit of cold mass (kJ/kg)	9.0	11.9
Main coil current (kA)	15.8	18.4
Extra correction current (kA)	16.2	18.4
Ampere-turns main coil (MAT)	19.4	22.5
Ampere-turns correction coils (MAT)	6.5	7.4

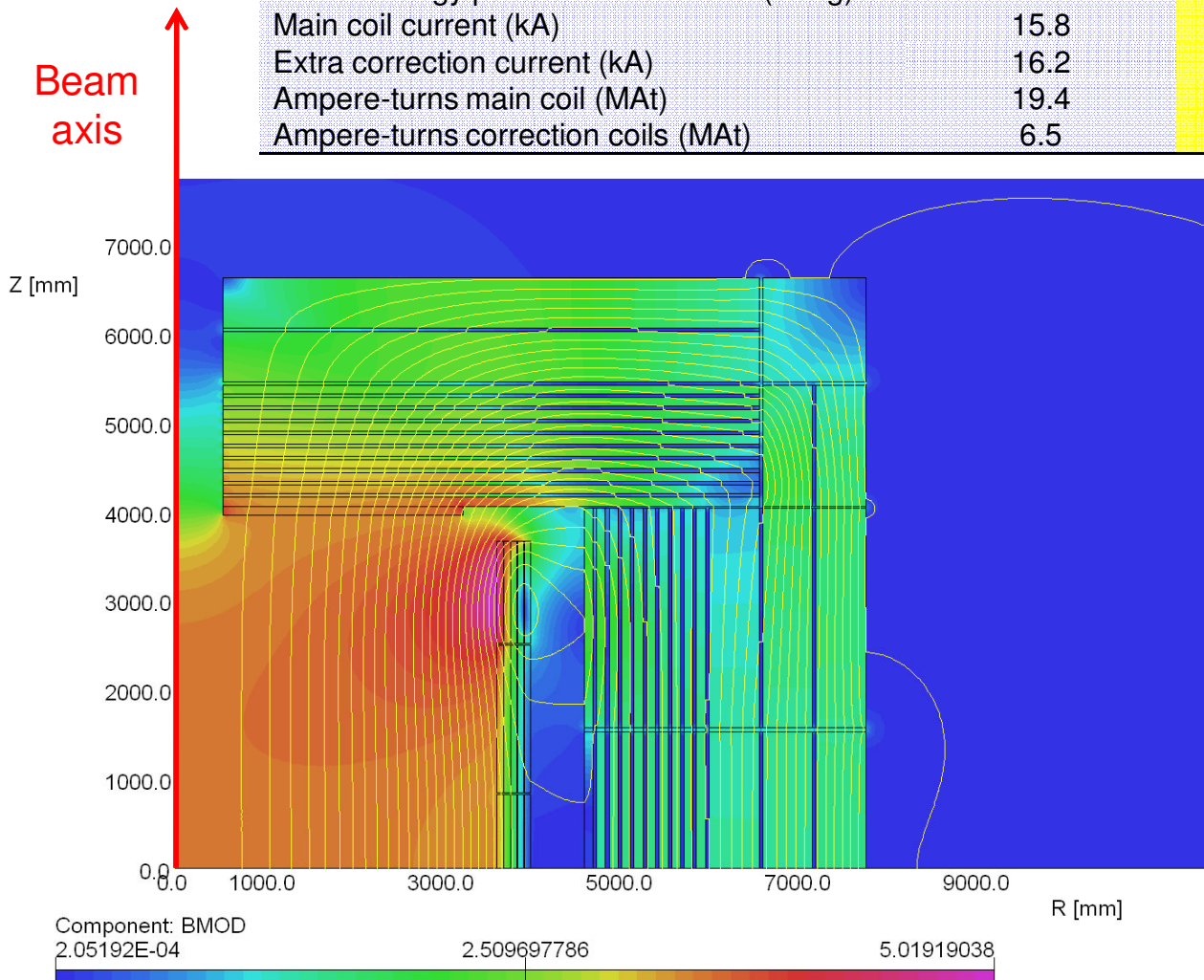

UNITS

- Length : mm
- Flux density : T
- Field strength : A m⁻¹
- Potential : Wb m⁻¹
- Conductivity : S m⁻¹
- Source density: A mm⁻²
- Power : W
- Force : N
- Energy : J
- Mass : kg

PROBLEM DATA

D:\ILD2\V5-Saclay\ILD-V5-Rin500mm-3-5T.st

Linear elements

Axi-symmetry

Modified R²vec.pot.

Magnetic fields

Static solution

Scale factor: 1.0

143037 elements

72004 nodes

197 regions

15/Oct/2009 17:04:26 Page 9





Field homogeneity:

homogeneous field in the volume of the TPC:

$$\Delta I (R) = \int_0^{z_{\max}} (B_r (R) / B_z (R)) dz$$

within the TPC volume:

$$z_{\max} = 2.25 \text{ m}$$

$$R_{\max} = 1.8 \text{ m}$$

The field homogeneity is adjusted with a FSP (Field Shaping Plate) and correction currents in some places of the coil at both ends.

Initial requirements :

Field homogeneity for ILD : $\Delta I (R) < 10 \text{ mm}$

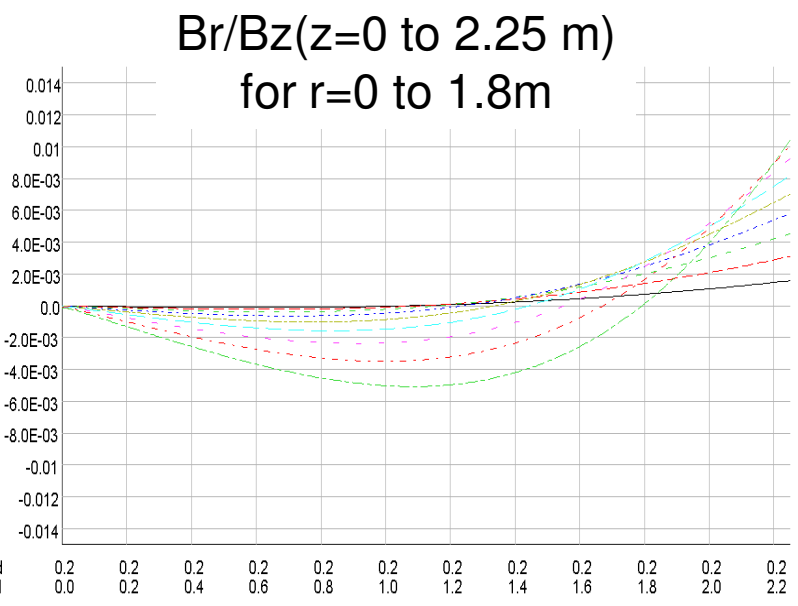
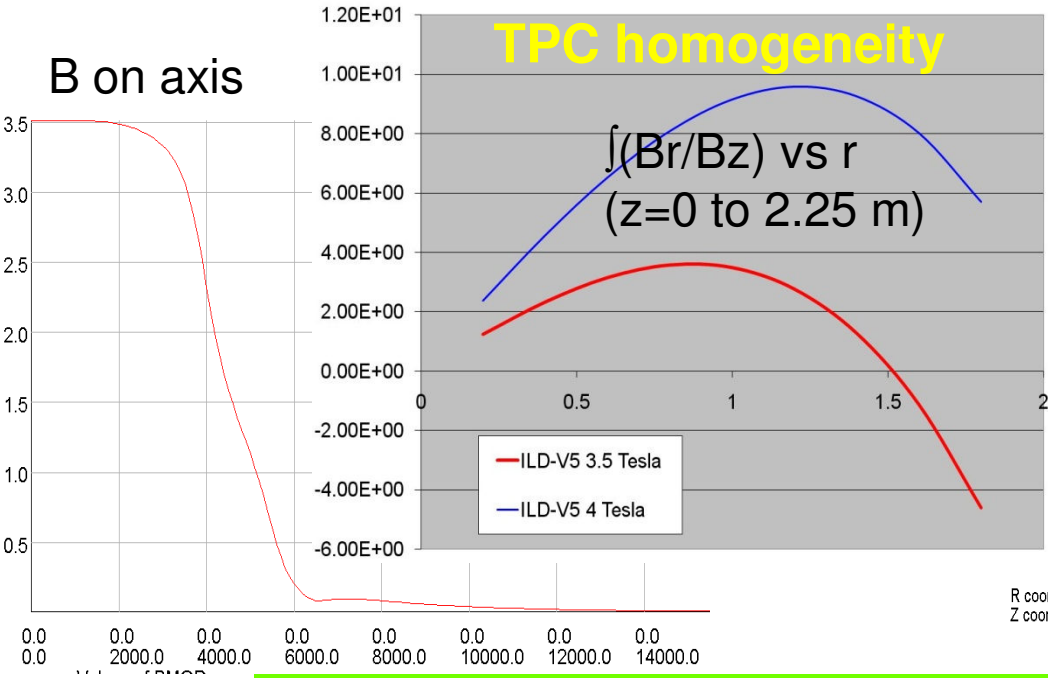
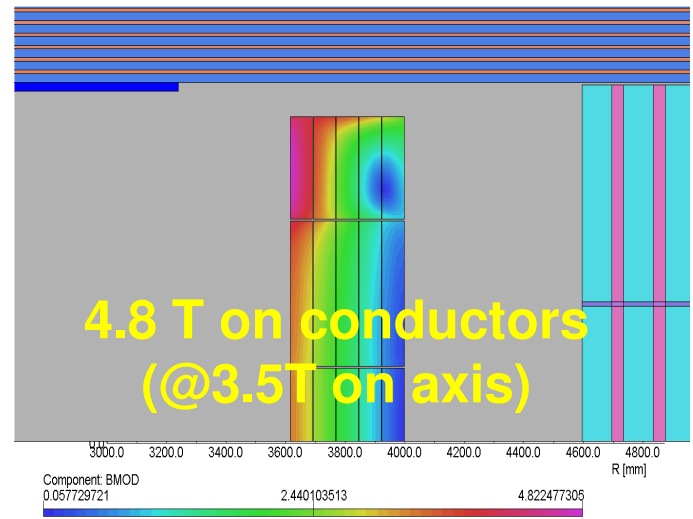
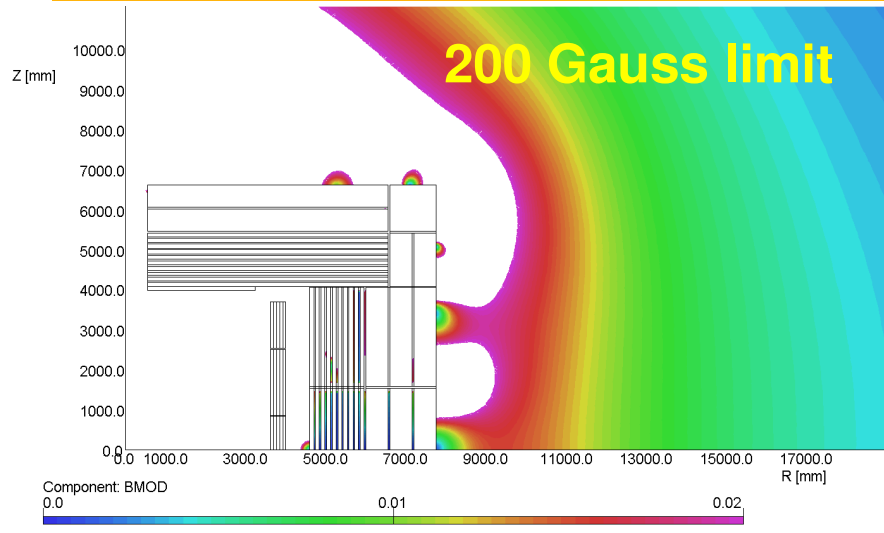

5 bands of conductor with 3.78 m inner radius wound on either side of IP. The coil pattern length is 3.67 m and the anti-DID coils are intended to be wound just outside (atop) the main ILD detector solenoid; however, the anti-DID conductor parameters are still TBD.

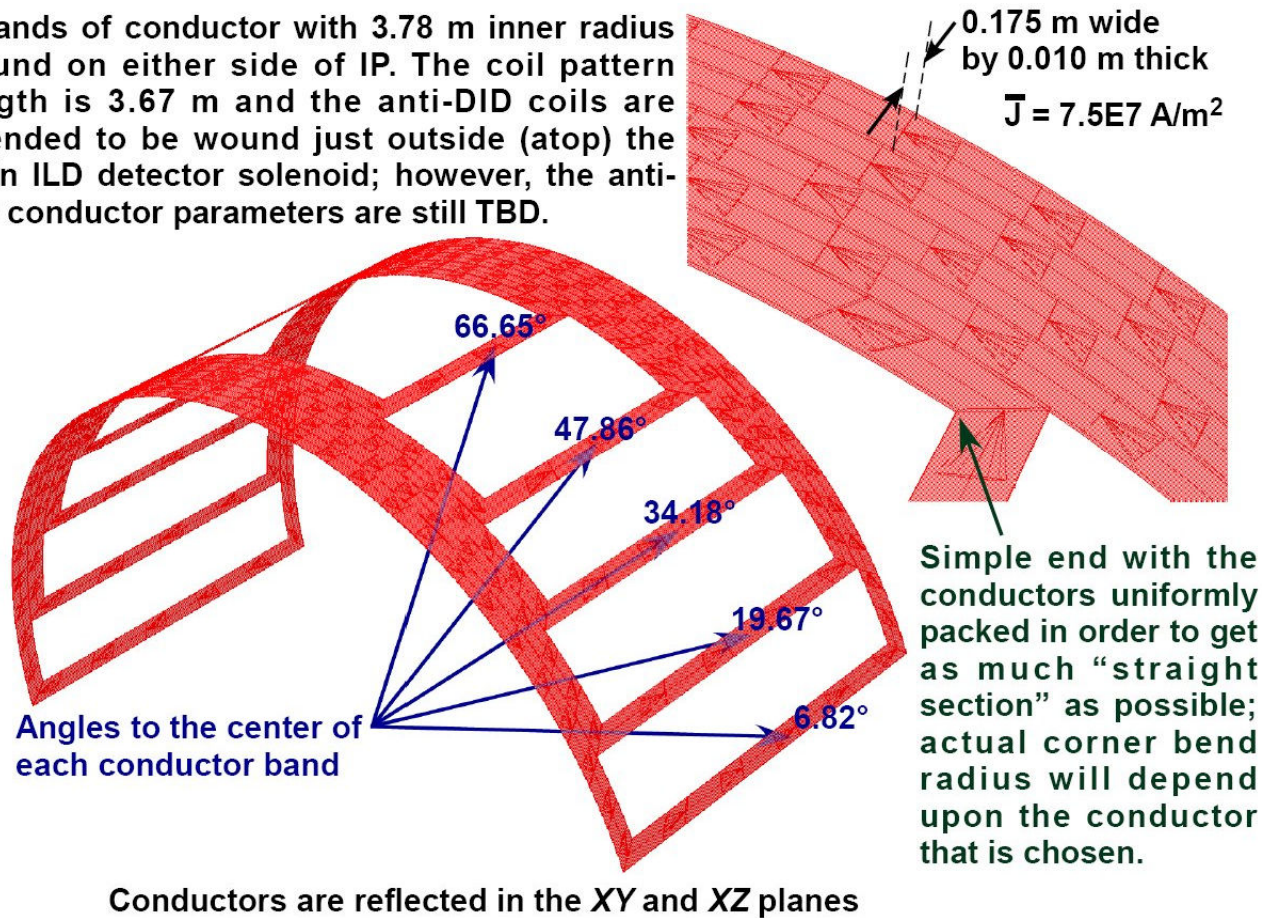

In the ILD design the outer radius of solenoid coil is : **$R_{out} = 4.00 \text{ m}$**

External radius of the Anti-DID has been extend to: **$R_{AD} = 4.3 \text{ m}$**

The thickness and width are unchanged : **10 mm , 175 mm**

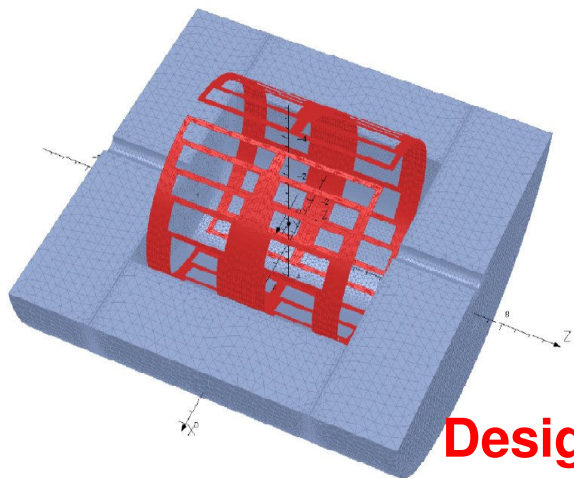
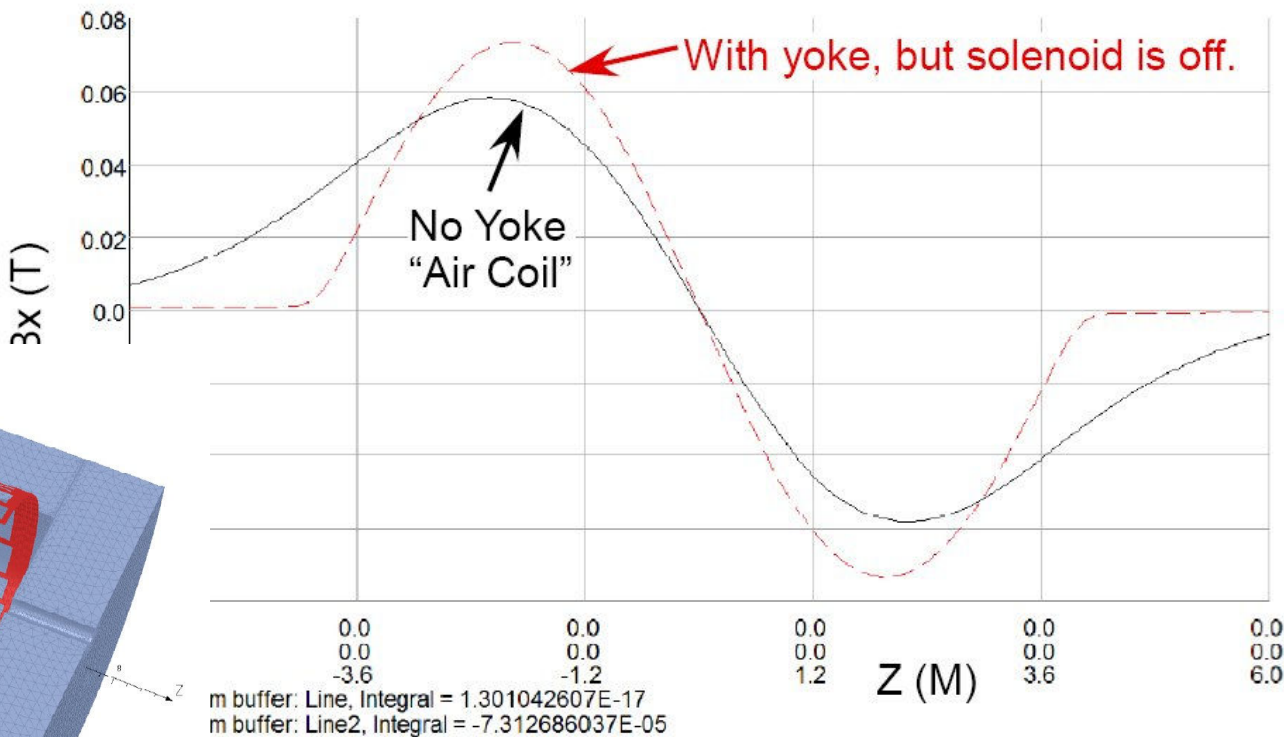

Design might not be optimized for the actual ILD Magnet

This model does not yet include the ILD solenoid, so the yoke is unsaturated. Note the sharp reduction compared to the "air coil" field near the endcap plate at $Z = 4$ m. When the inner layers of the endcap do become highly saturated with the main solenoid being energized, the result for the anti-DID field will lie between these curves in the near endcap region.

$J=75 \text{ A/mm}^2$

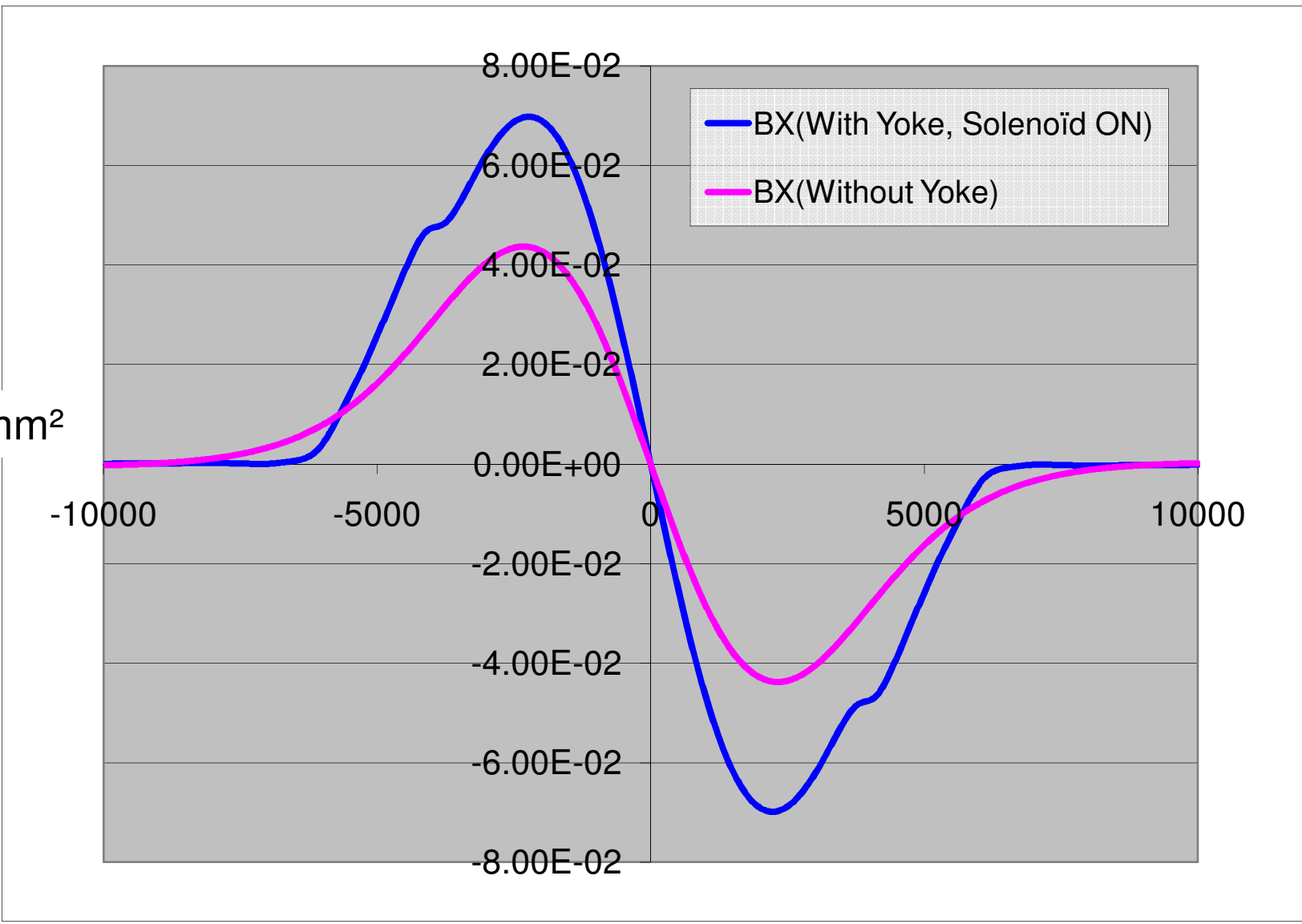

Component from anti-DID: B_x

19/juin/2009 10:21:58

Surface contours: BMOD

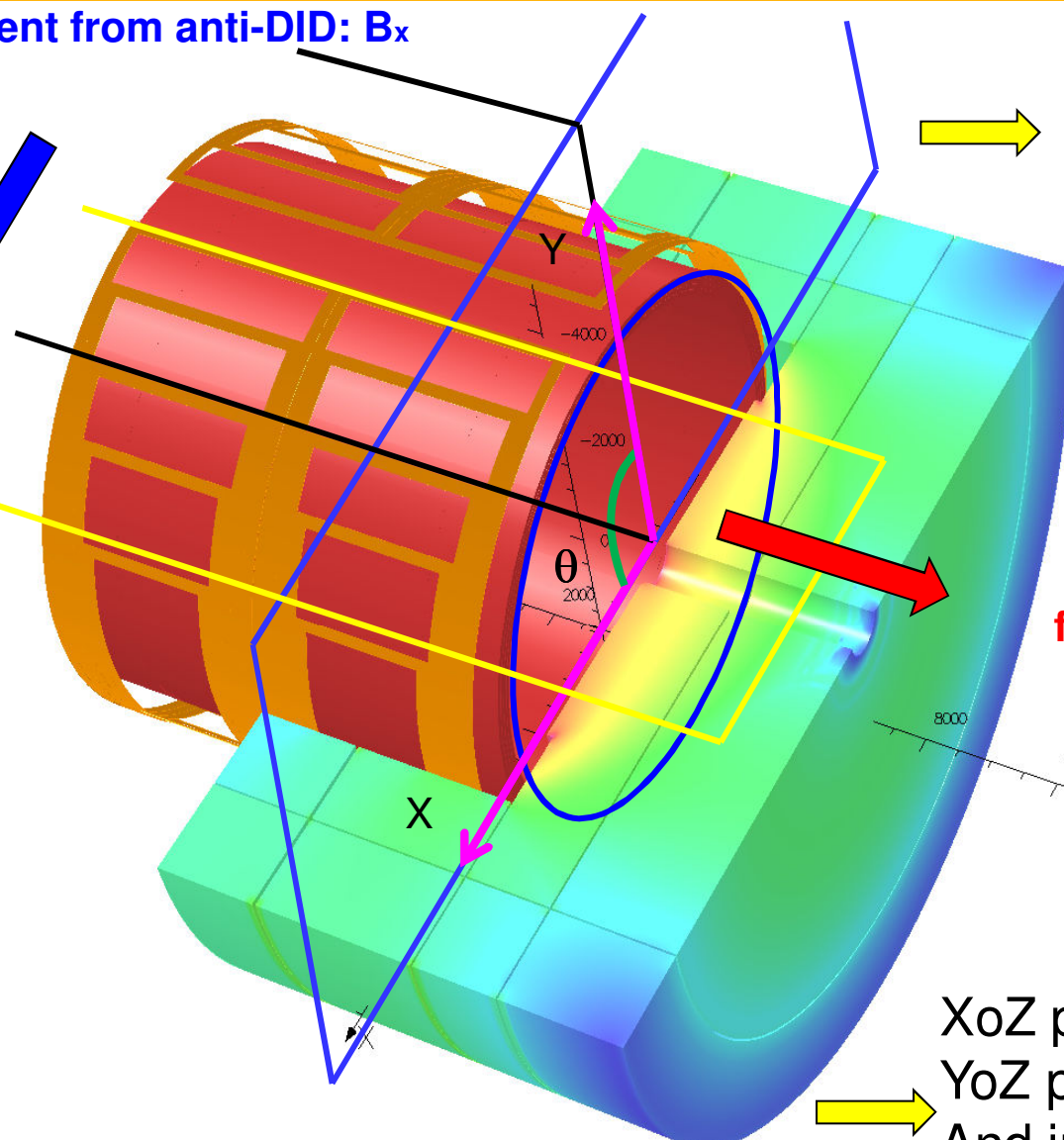
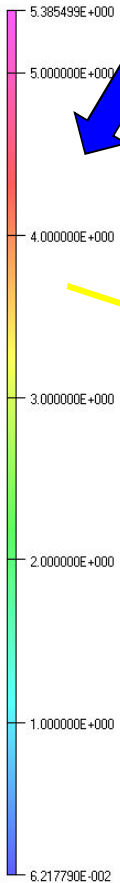

Cylindrical symmetry broken

Component from solenoid: B_z

Look at:
 XoZ plane
 YoZ plane
 And in between (Θ)

25/Jan./2010 15:57:55

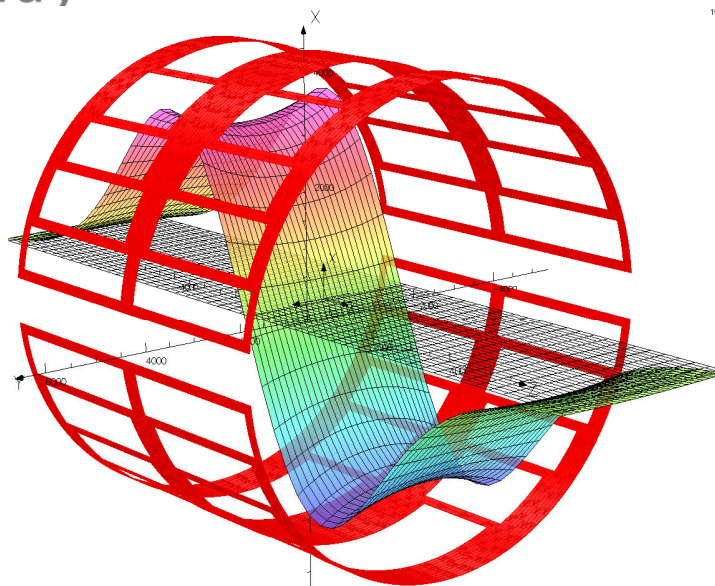
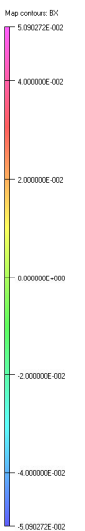

B_x from anti-DID in air

Vector Fields
software for electromagnetic design

19

26/Jan./2010 11:33:33

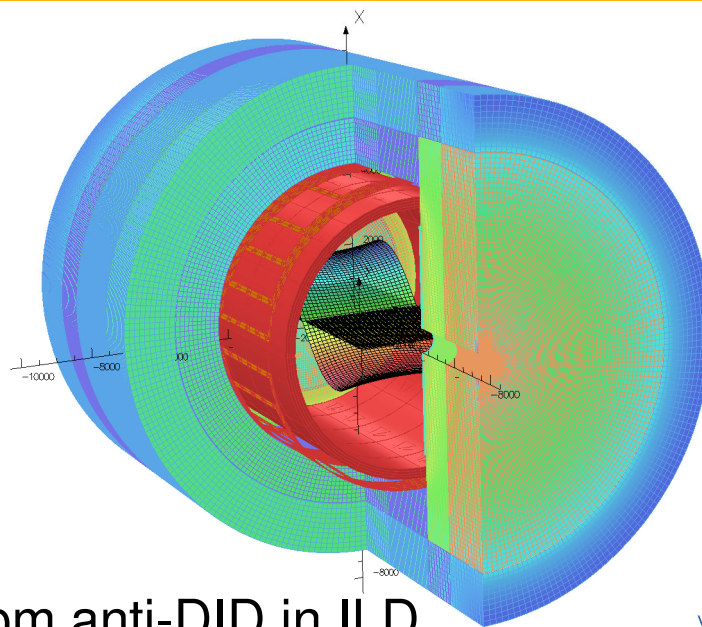
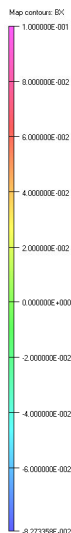

B_x from anti-DID in ILD

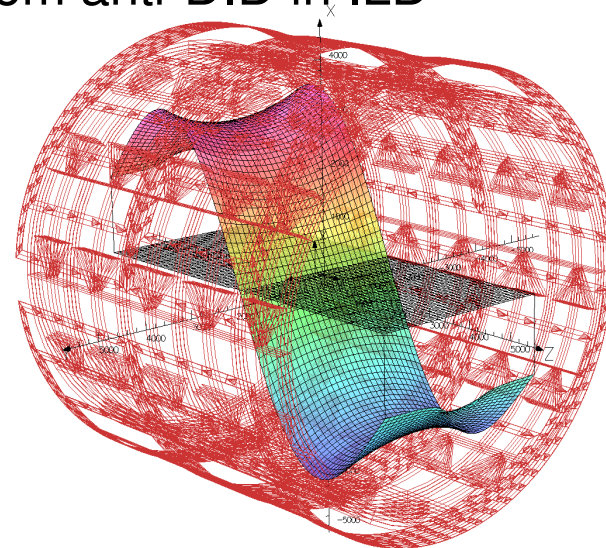
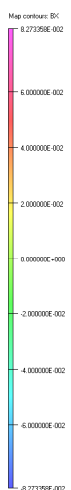

Vecto

UNITS	
Length	mm
Magn Flux Density	T
Magn Field	A/m
Magn Scalar Pot	A/m
Magn Vector Pot	V/m
Elec Flux Density	C/m ²
Elec Field	V/m
Conductivity	S/m
Current Density	A/m ²
Power	W
Force	N
Energy	J
Mass	kg

10501105

PROBLEM DATA

V3.1.0.164-Sub-Icon-DID.rp3
 TOSCA Magnetics
 Nonlinear materials
 Simulation No: 1 of 1
 3256448 elements
 5244101 nodes
 25 conductors
 Nonly imported fields
 Activated in global coordinates
 Reflection in Z plane (Y field=0)
 Reflection in X plane (Y field=0)
 Reflection in Z plane (Y field=0)

Field Panel Local Coordinates
 Local=Global

FIELD EVALUATIONS

Cartesian CARTESIAN 30M100
 (mm)
 x=0.0, y=1000.0, z=1800.0
 z=3000.0 (n=30000)

Solenoid + Icor, no anti-DID

$$\int (B_r/B_z) dz = \int (B_x/B_z) dz \text{ for } \theta=0^\circ$$

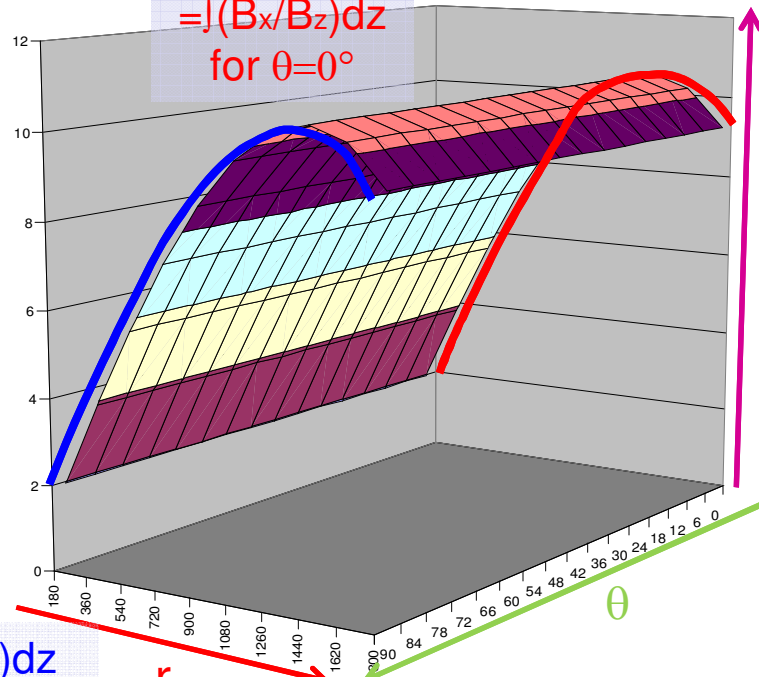

$$\int (B_r/B_z) dz$$

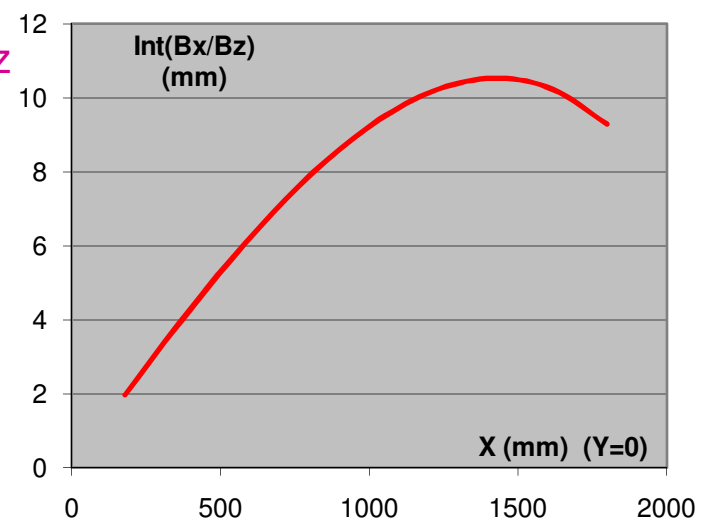

$$\int (B_r/B_z) dz = \int (B_y/B_z) dz \text{ for } \theta=90^\circ$$

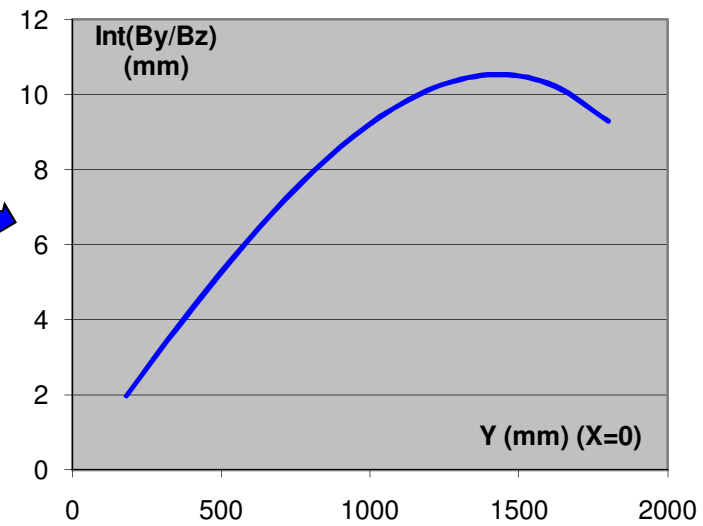
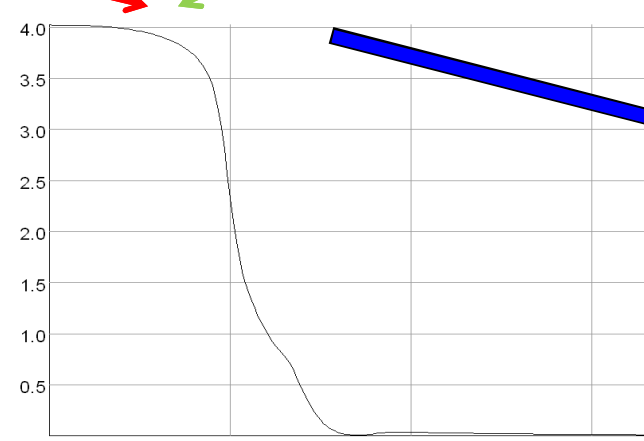

X coord 0.0 0.0 0.0 0.0
 Y coord 0.0 0.0 0.0 0.0
 Z coord 0.0 4000.0 8000.0 12000.0
 Component: BMOD, from buffer: Line, Integral = 17419.1775660661

Solenoid Icor=0, no anti-DID

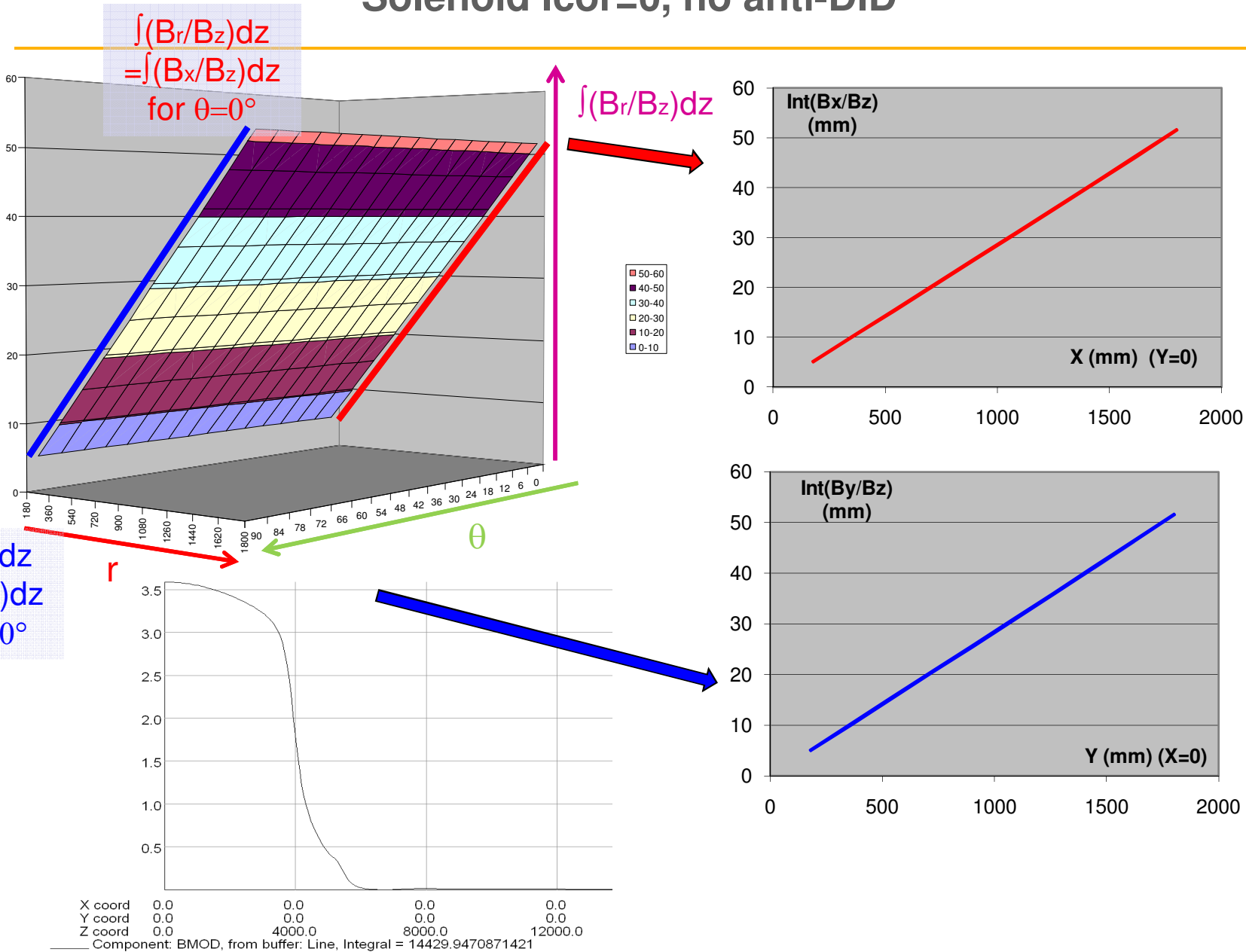

Solenoid + Icor + anti-DID

$$\int (B_r/B_z) dz = \int (B_y/B_z) dz \text{ for } \theta=90^\circ$$

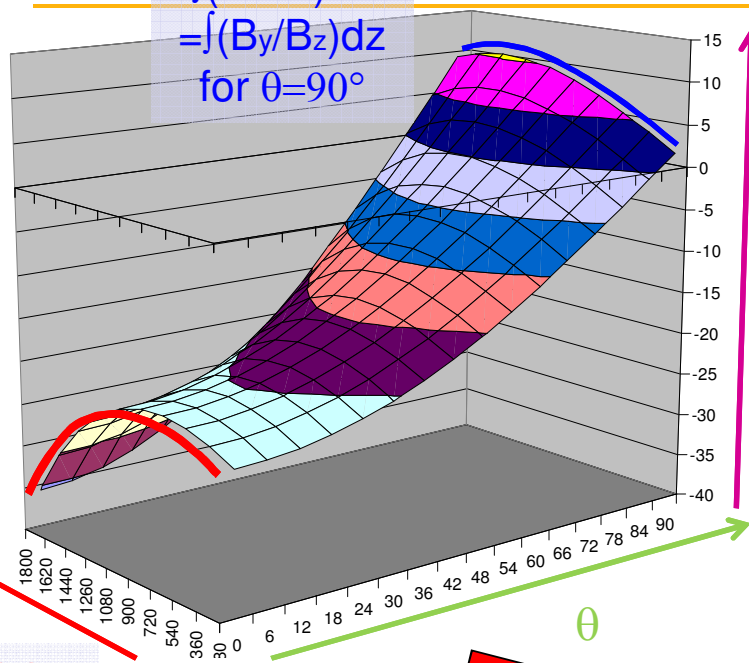

$$\int (B_r/B_z) dz$$

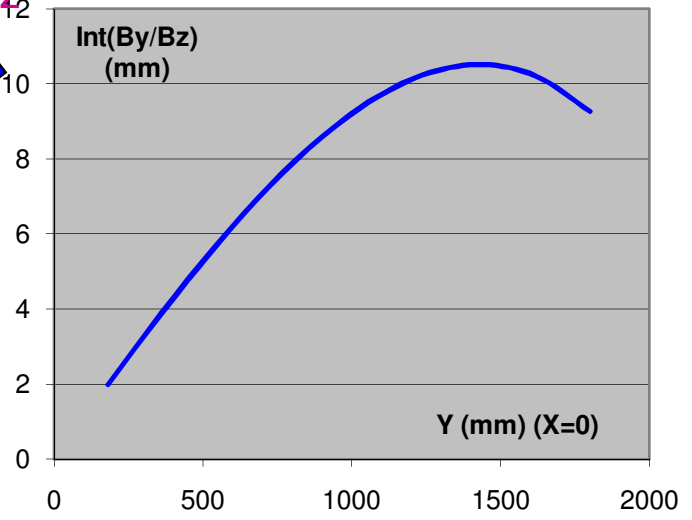

$$\int (B_r/B_z) dz = \int (B_x/B_z) dz \text{ for } \theta=0^\circ$$

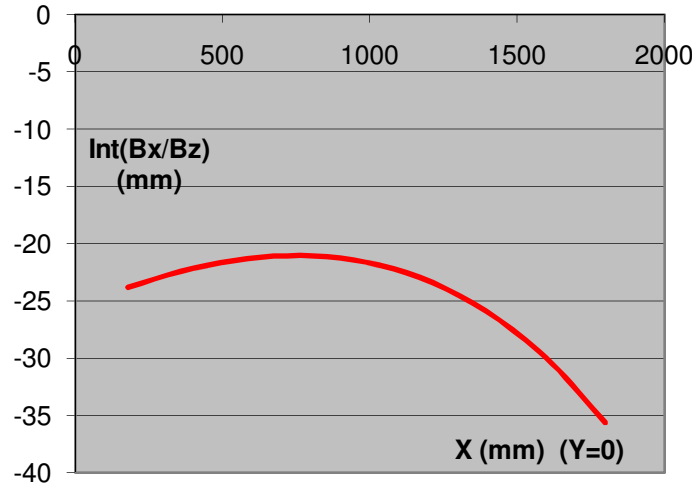
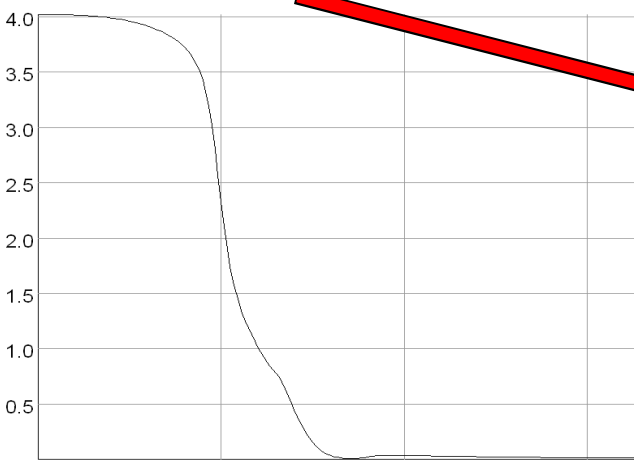

X coord 0.0 0.0 0.0 0.0
 Y coord 0.0 0.0 0.0 0.0
 Z coord 0.0 4000.0 8000.0 12000.0
 Component: BMOD, from buffer: Line, Integral = 17420.1276839207

Solenoid Icor=0, + anti-DID

$$\int (B_r/B_z) dz = \int (B_y/B_z) dz \text{ for } \theta=90^\circ$$

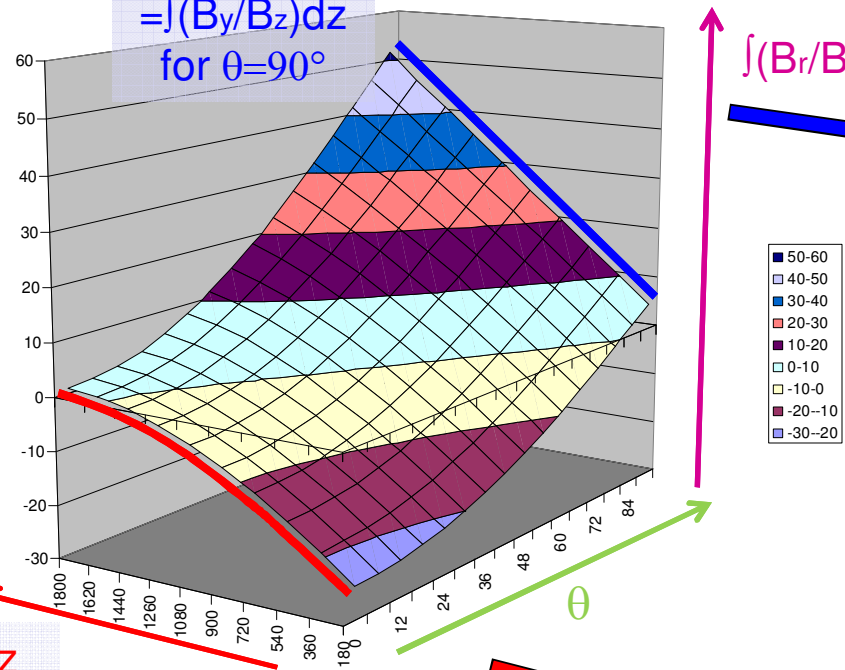

$$\int (B_r/B_z) dz = \int (B_x/B_z) dz \text{ for } \theta=0^\circ$$

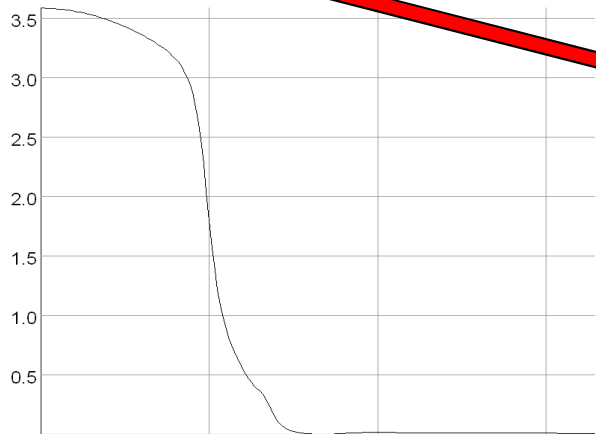

X coord 0.0 0.0 0.0 0.0
Y coord 0.0 0.0 0.0 0.0
Z coord 0.0 4000.0 8000.0 12000.0
Component: BMOD, from buffer: Line, Integral = 14431.6398709189

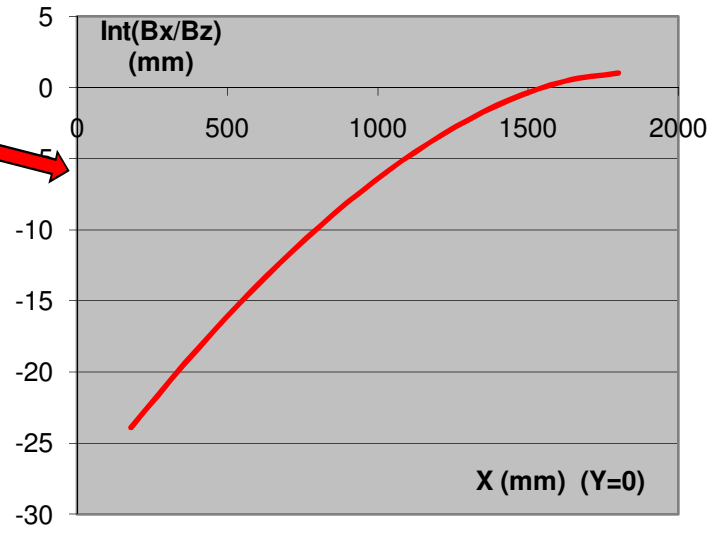
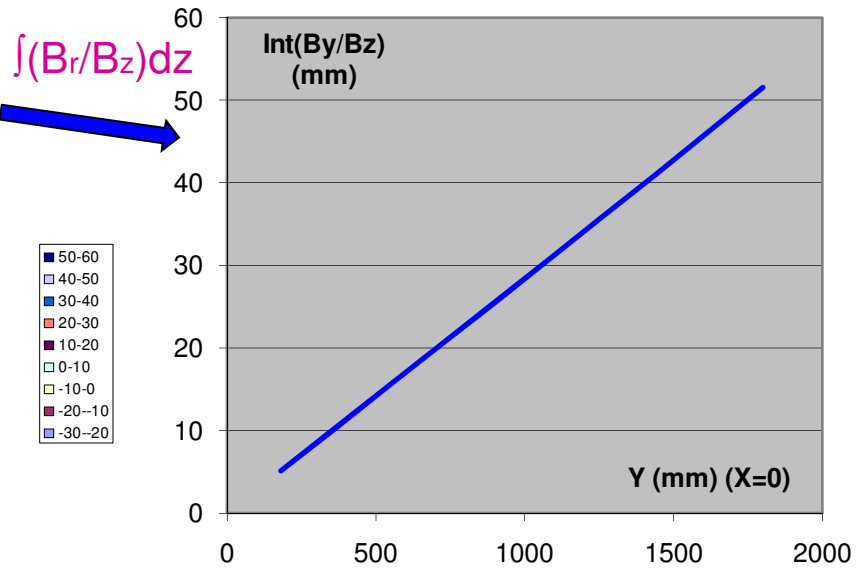

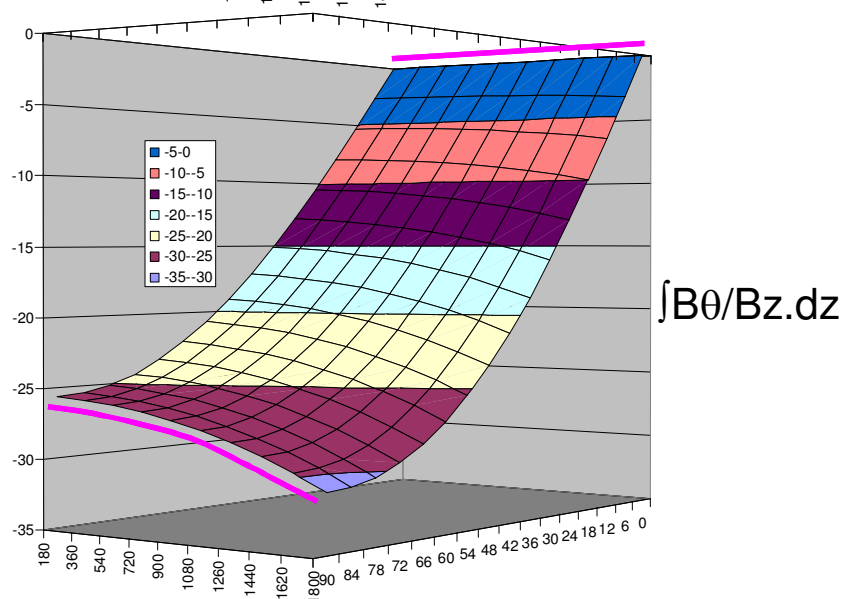
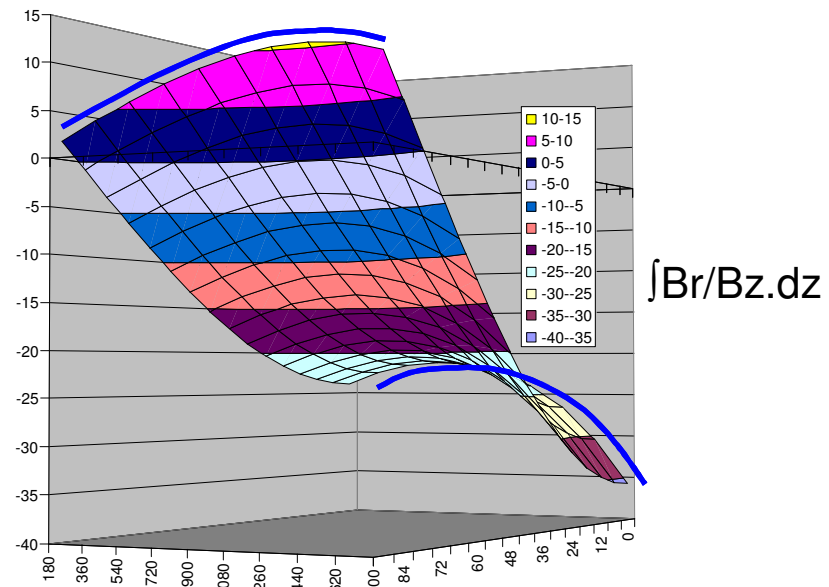
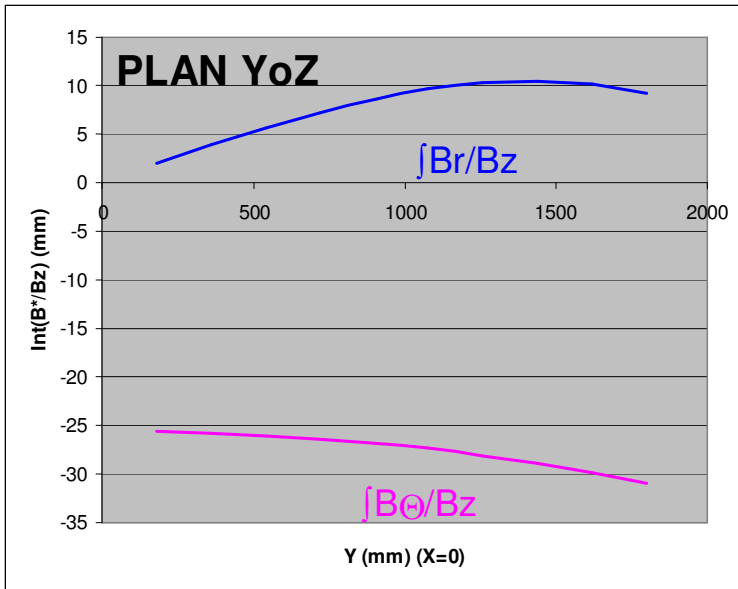
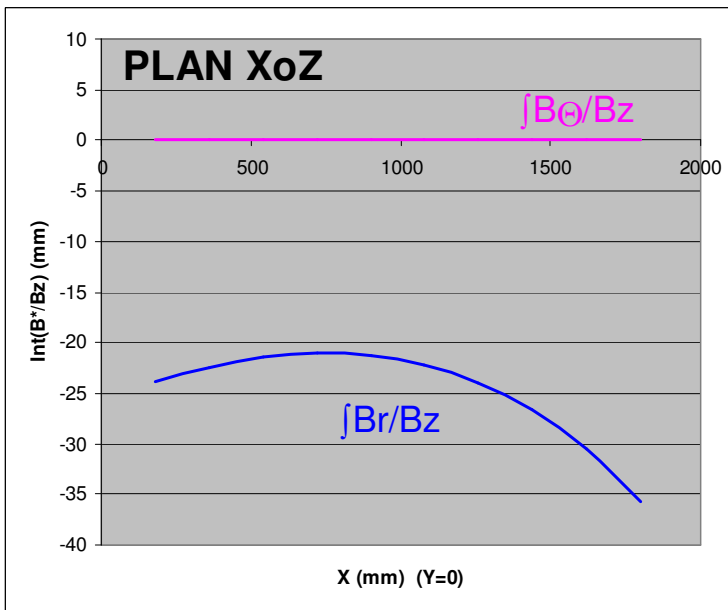



-Yoke dimension frozen

-Solenoid coil dimensions frozen

-Anti-DID first simulation with solenoid and yoke

-No optimization of Anti-DID position, geometry or current since first design of *Brett Parker*.

-Optic simulations are underway at Saclay (*Reine Versteegen, PhD* «*Conception et Optimisation de la Région d'Interaction d'un futur collisionneur linéaire électron-positon* »).

-Preliminary results show that the strength of the anti-DID seems oversized. **More optics calculations are needed to optimize the anti-DID.**

-Correction coils increase the peak field, the stored energy and the forces and stress. They need extra hardware (conductor with higher current, current leads, power supply, electrical circuit, instrumentation). This has non negligible consequences on the cost and safety of the magnet.
Consequently, the settling of the correction coils must be strongly justified.

Thank you for your attention



ILD
International
Large
Detector



ILD Solenoid :

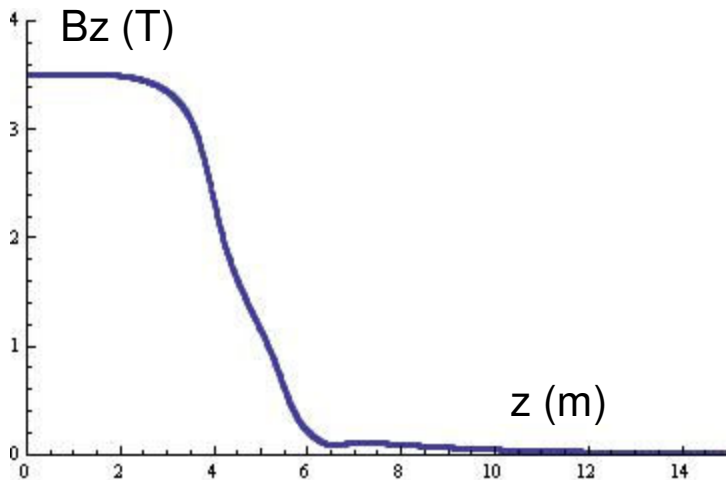

Solenoid field lines:

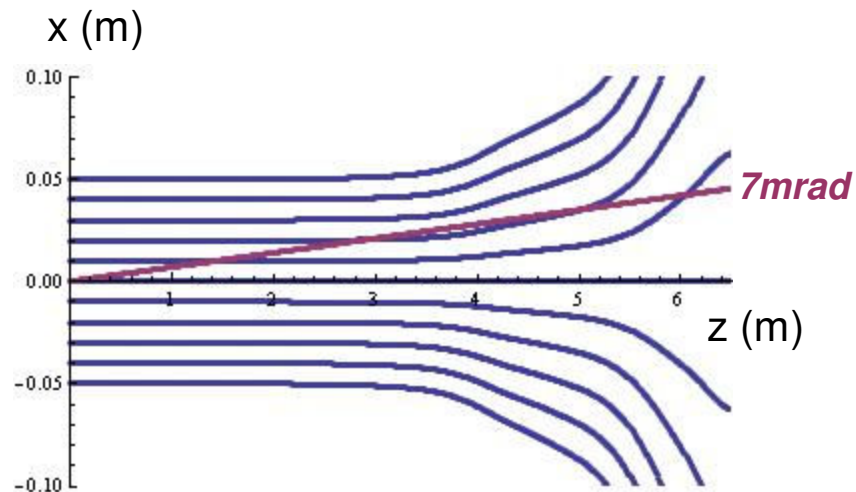

Anti-DID :

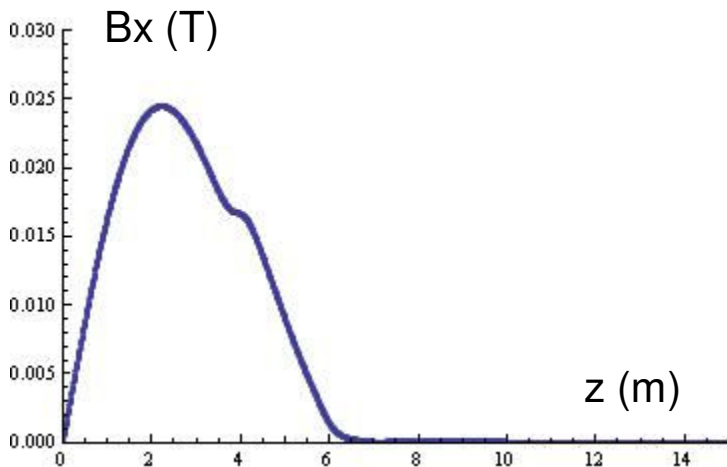

Solenoid+Anti-DID field lines:

