

ILC Main Linac Superconducting Cryogen Free Splittable Quadrupole Technical Design

V. Kashikhin for Superconducting Magnet Team

- **Splittable quadrupole milestones**
- **ILC Quadrupole Model 1 test results**
- **Quadrupole parameters and concept**
- **Quadrupole magnetic design**
- **Quadrupole thermal and mechanical design**
- **Magnet design modifications**
- **Quadrupole installation inside Cryomodule**
- **FY10 quadrupole fabrication and schedule**
- **Summary**

Splittable Quadrupole Milestones

Task from ILC Project Management: Design and manufacture Splittable Quadrupole to provide the quadrupole package installation and replacement outside of a very clean room.

Milestones:

- **Magnetic, mechanical, thermal design.**
- **Quadrupole drawings.**
- **Parts order.**
- **Quadrupole manufacturing.**
- **Instrumentation and preparation for test.**
- **Quadrupole test.**

Splittable Quadrupole Design Issues

Main issues:

- **Stable magnetic and mechanical design.**
- **Effective conductive cooling.**
- **Easy installation and disassembly around beam pipe.**
- **Quadrupole+BPM rigid connection.**
- **Magnetic axis stability.**
- **Quench protection.**
- **Mechanical properties of SC wire insulation.**
- **Fringe fields.**

ILC Quadrupole Specification

Parameter	Unit	Value
Integrated gradient	T	36
Aperture	mm	78
Effective length	mm	660
Peak gradient	T/m	54
Field non-linearity at 5 mm radius \square	%	0.05
Dipole trim coils integrated strength	T-m	0.075
Quadrupole strength adjustment for BBA	%	-20
Magnetic center stability at BBA	micron	5
Magnetic center offset in cryomodule	mm	0.5
Quadrupole azimuthal offset in cryomodule	mrad	0.3
Liquid helium temperature	K	2

Quadrupole Integrated Gradient

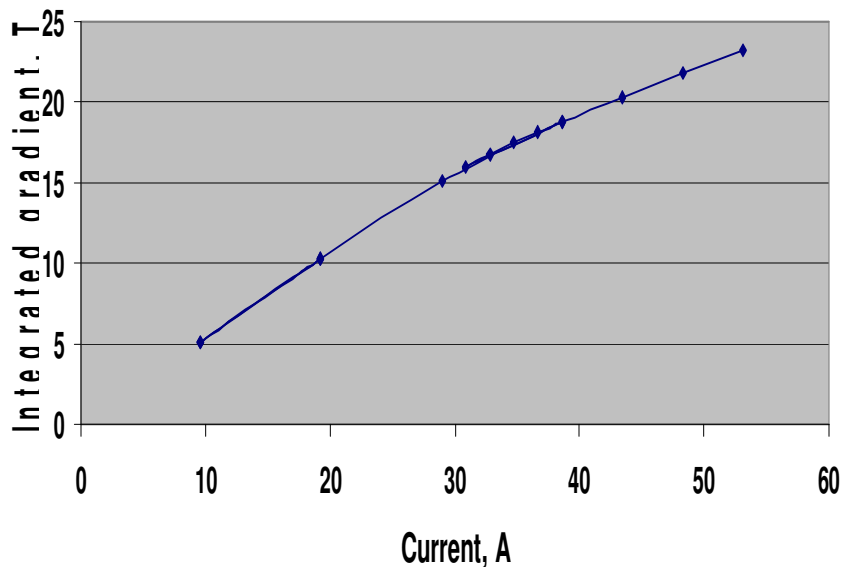

RTQ01 Quench History

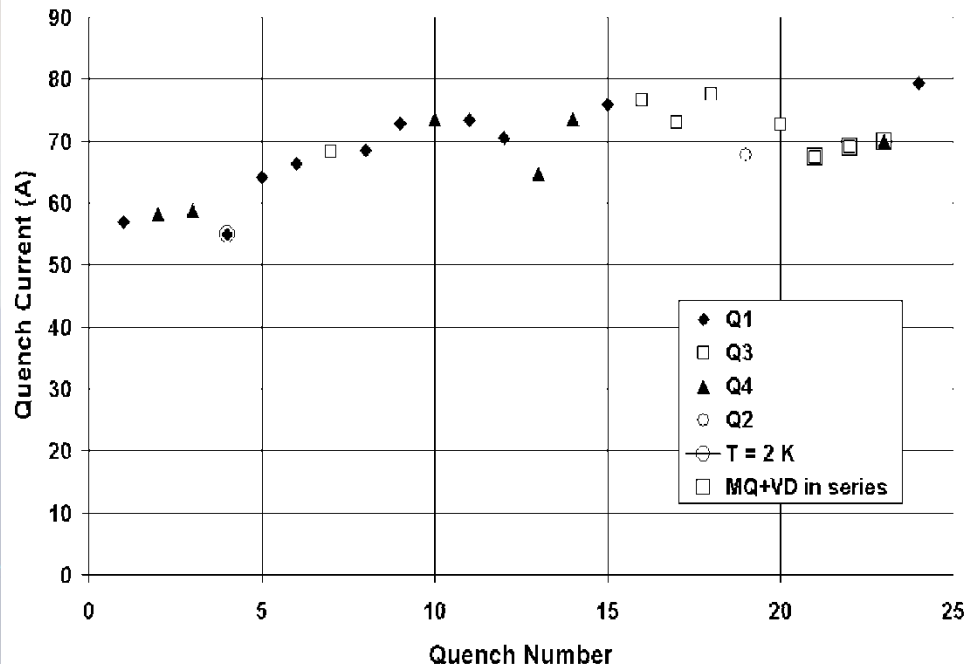

The magnet integrated gradient was measured at 700 turns/pole.

200 turns were used for dipoles. The final points at 60-80 A on the left figure are not shown.

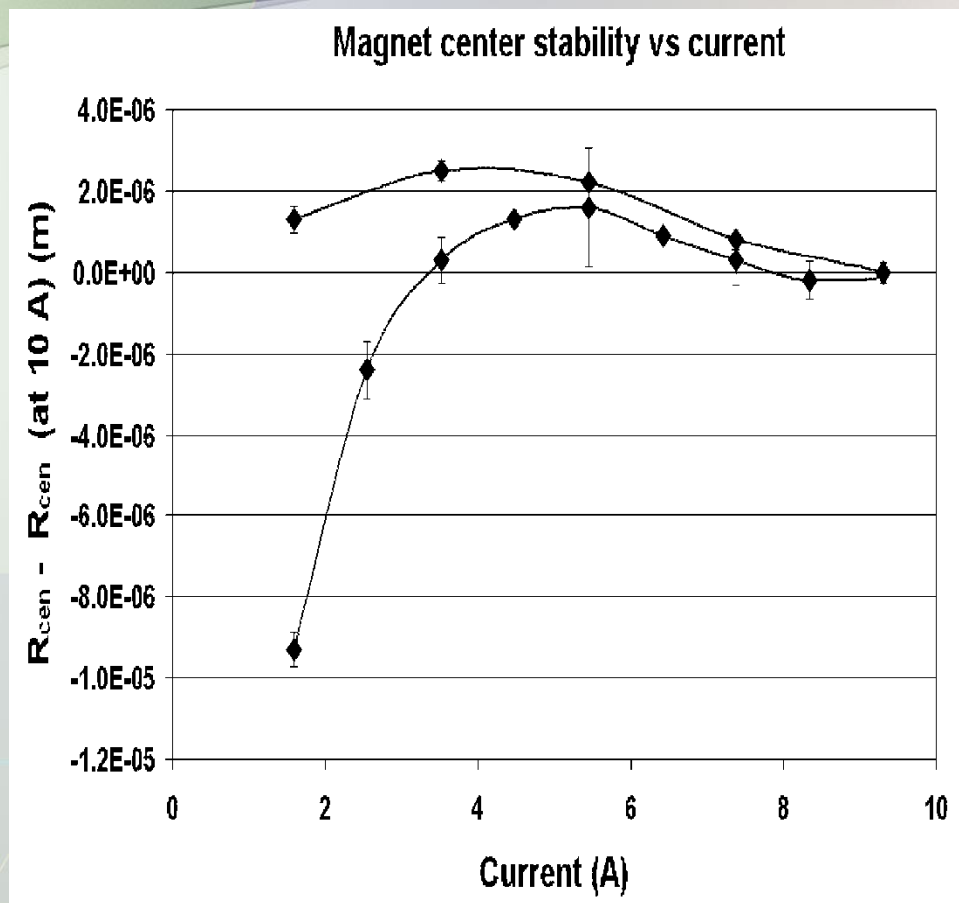

One might conclude that the magnet center moves in the limits of $\pm 2.5\ \mu\text{m}$ when the current is between 3 A and 10 A.

The determination of the quadrupole magnet center relative to the probe position was done using the standard technique of zeroing the dipole component assuming that it is purely generated from a probe offset. As a result, the quadrupole center coordinates, x_{cen} and y_{cen} were obtained. Distribution of the distance R_{cen} between the probe axis and the quadrupole center of the magnet for approximately 200 measurements.

The first sets of measurements were performed when the magnet was powered up to 10 A. Left figure shows the result of the quadrupole center displacement ($DR_{cen}(I) = R_{cen}(I) - R_{cen}(10A)$) versus the current ramp where R_{cen} of the 10 A measurement was subtracted from the other currents.

Magnet center stability vs. current

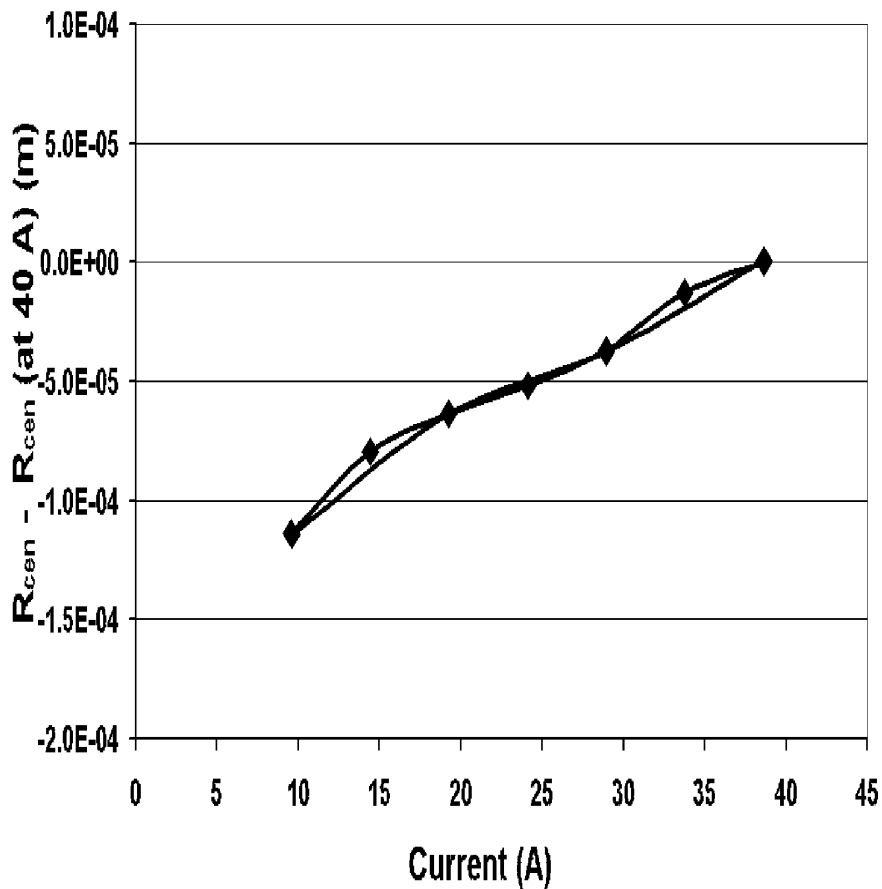

In the next set of measurements, we increased the operational current, covering to the region of 10-40 A. The result is shown in left figure.

Unexpectedly, the quadrupole center moved linearly with a derivative $4 \mu\text{m}/\text{A}$ of quadrupole current. It corresponds to $8 \mu\text{m}$ at 10 A and $32 \mu\text{m}$ at 40 A during 20% current change at BBA.

This effect will be investigated during next tests and may be caused by the probe or quadrupole coils offsets, or unequal number of turns in the coils.

Magnet center stability vs current

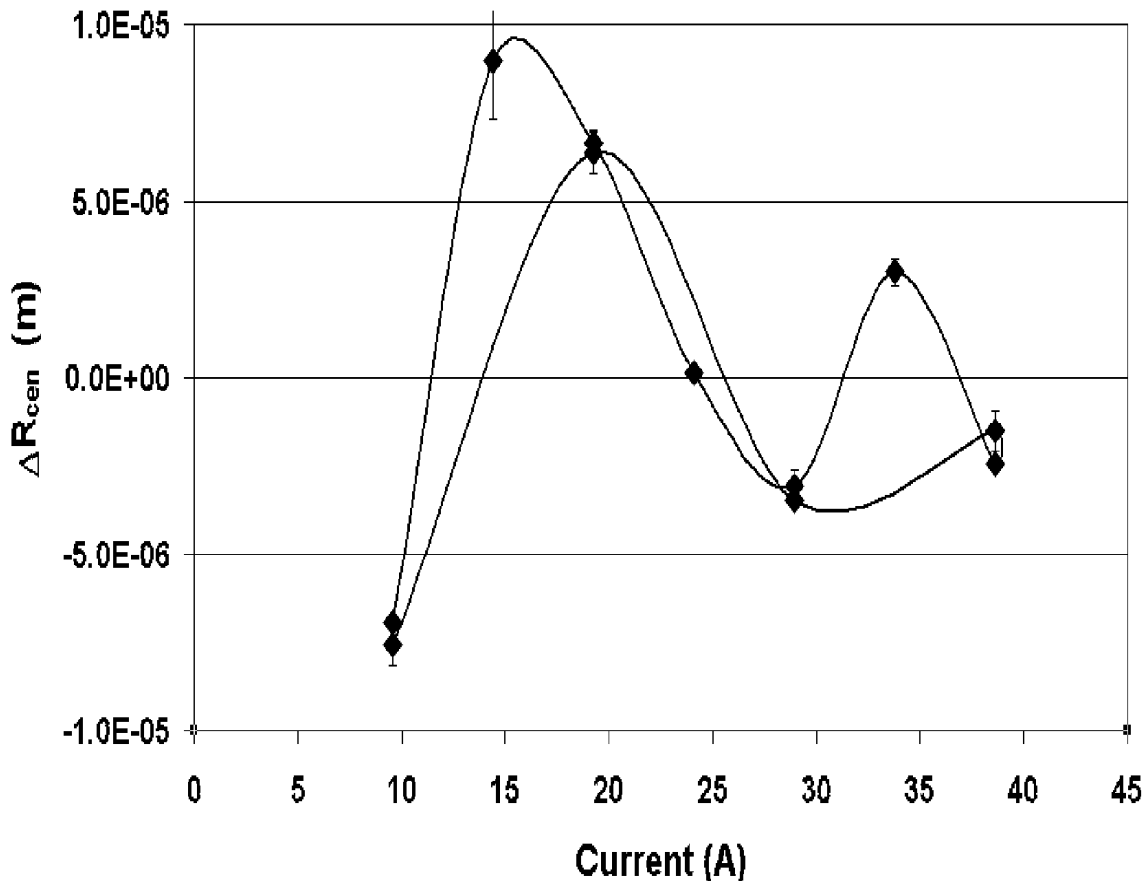

The quadrupole package was assembled with two built-in dipole correctors: horizontal and vertical.

Utilizing these two correctors, one could compensate the linear dependence as shown in the figure.

After subtracting this correction, the variation of quadrupole center is in the limits of $\sim 8 \mu\text{m}$

ILC HGQ01 Dipole Correctors

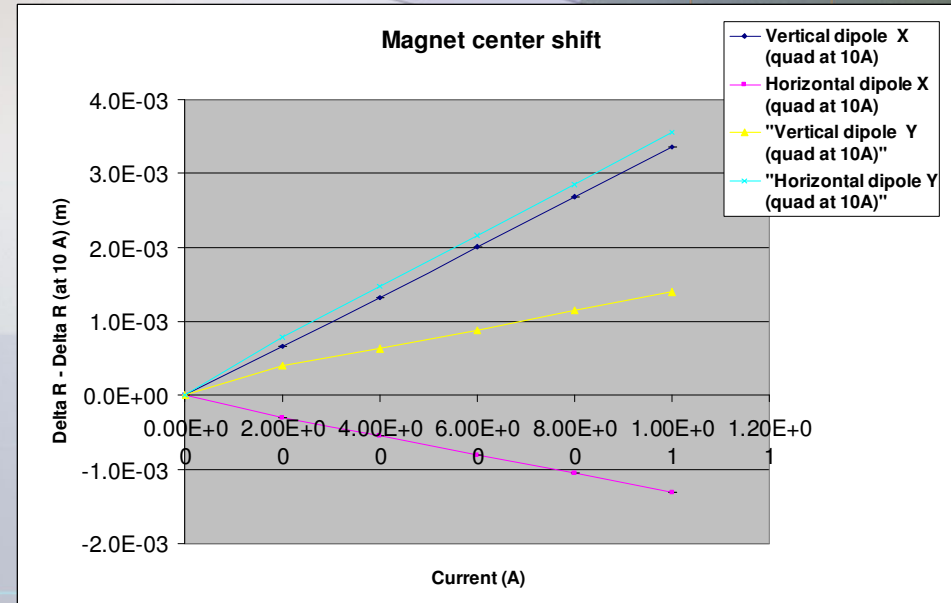
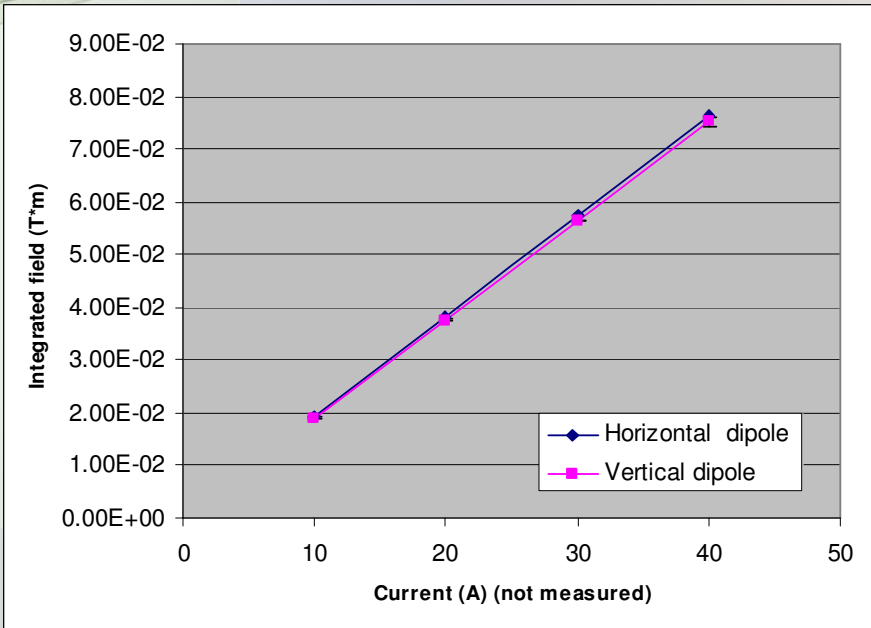

The dipole correctors generate specified integrated field 0.075 T-m at current 40 A

Dipoles provide linear magnetic center shift.

Quadrupole Mechanical Concept

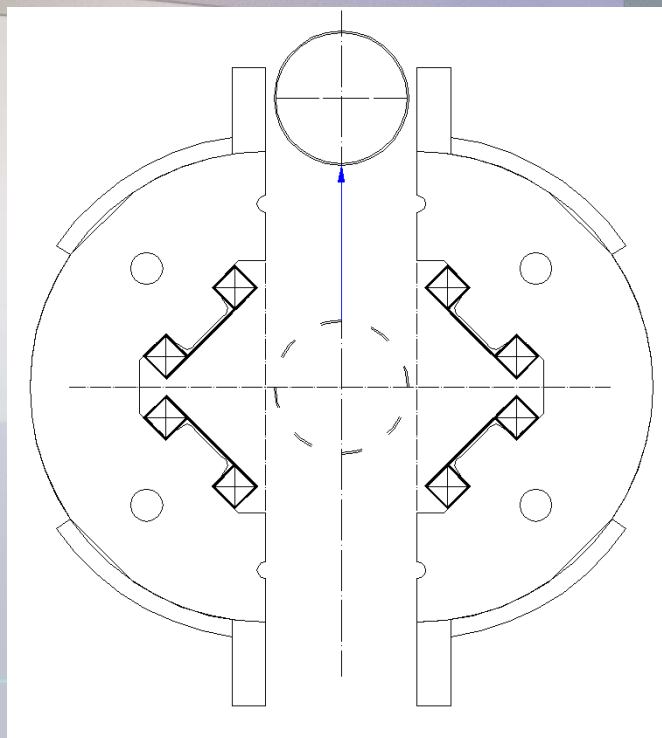
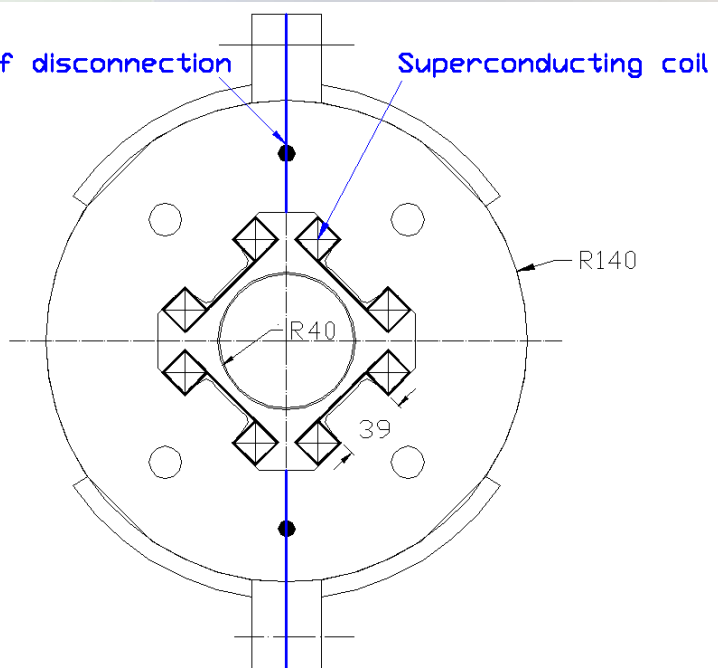

It was chosen the quadrupole design with racetrack coils which easy to split in vertical or horizontal direction.

QUADRUPOLE MODEL PARAMETERS

Parameter	Unit	Value
Peak current at 36 T gradient	A	100
Magnet length	mm	680
NbTi superconductor diameter	mm	0.5
Superconductor filament size	μm	3.7
Superconductor critical current at 5 T and 4.2 K	A	200
Coil maximum field	T	3.3
Quadrupole coil number of turns/pole		700
Yoke outer diameter	mm	280

Magnet Assembly Tolerances

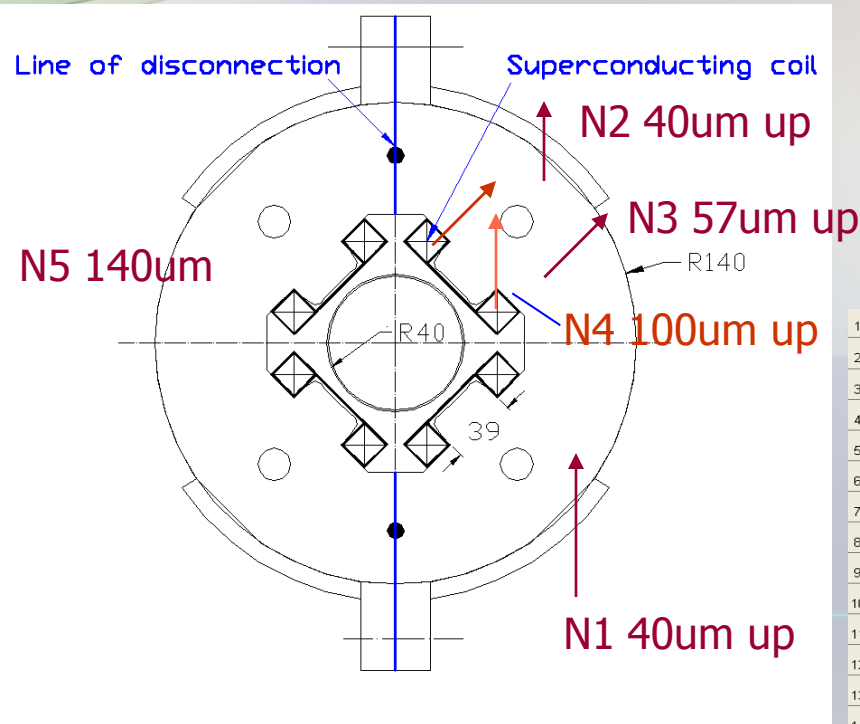

1 unit = 1 Gauss= 1um

Case #	Description
0	Standard ML quadrupole. Gradient 54 T/m. No correction coils.
1	Right half of the magnet displaced 40 microns up.
2	1st Quadrant displaced 40 microns up.
3	1st Quadrant displaced 40 microns right and 40 microns up.
4	Coil displaced 100 microns up.
5	Coil displaced 100 microns up and 100 microns right.

		Bn/B2							
n	An	Bn	Case0	Case1	Case2	Case3	Case4	Case5	
1									
2									
3	1	0.00	0.000000	0.0	3.7	-1.4	-13.3	2.1	-15.6
4	2	0.00	0.541954	10000	10000	10000	10000	10000	10000
5	3	0.00	0.000000	0.0	-2.4	-2.0	-0.9	-3.5	-1.3
6	4	0.00	0.000000	0.0	-1.7	-1.0	-0.7	-1.5	-0.7
7	5	0.00	0.000000	0.0	-0.4	-0.2	0.1	-0.4	0.2
8	6	0.00	-0.000182	-3.4	-4.1	-3.7	-3.7	-3.9	-3.8
9	7	0.00	0.000000	0.0	-0.2	-0.1	0.0	-0.2	0.0
10	8	0.00	-0.000002	0.0	-0.4	-0.2	-0.2	-0.3	-0.3
11	9	0.00	0.000000	0.0	-0.1	-0.1	0.0	-0.1	0.0
12	10	0.00	0.000000	0.0	-0.3	-0.1	-0.1	-0.2	-0.2
13									
14									
		Bn/B2							
n	An	Bn	Case0	Case1	Case2	Case3	Case4	Case5	
15									
16	1	0.00	0.000000	0.0	3.7	-1.6	-13.5	2.7	-13.1
17	2	0.00	0.468237	10000	10000	10000	10000	10000	10000
18	3	0.00	0.000000	0.0	-2.4	-2.0	-1.0	-3.2	-1.1
19	4	0.00	0.000000	0.0	-1.7	-1.0	-0.7	-1.3	-0.6
20	5	0.00	0.000000	0.0	-0.4	-0.2	0.1	-0.4	0.1
21	6	0.00	-0.000163	-3.5	-4.2	-3.8	-3.9	-4.0	-3.8
22	7	0.00	0.000000	0.0	-0.2	-0.1	0.0	-0.2	0.0
23	8	0.00	-0.000001	0.0	-0.4	-0.2	-0.2	-0.3	-0.2
24	9	0.00	0.000000	0.0	-0.1	-0.1	0.0	-0.1	0.0
25	10	0.00	0.000000	0.0	-0.3	-0.1	-0.1	-0.2	-0.1

M. Lopes

Updated Quadrupole Package Cross-Section

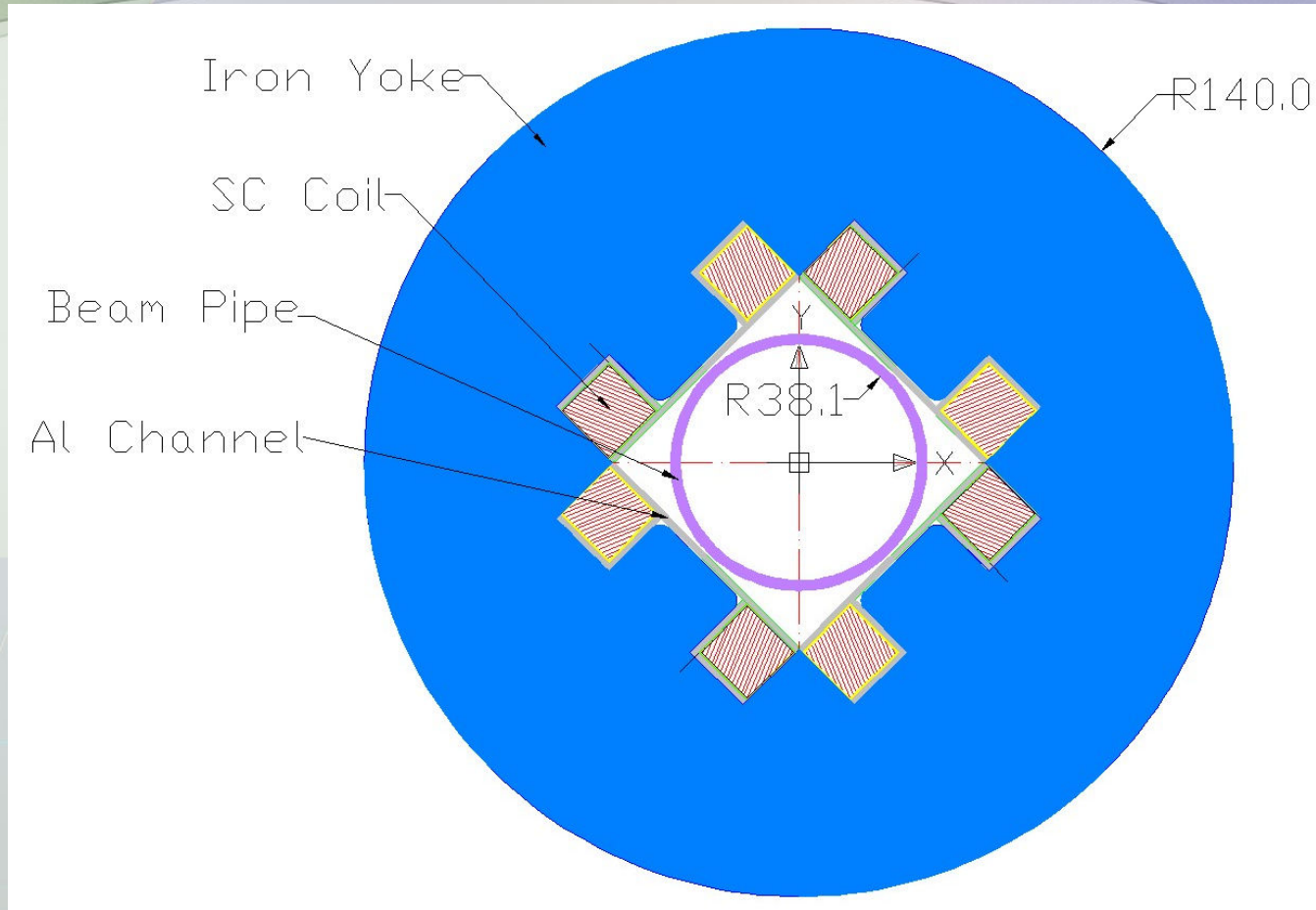

Updated design. Coil mounted and glued inside yoke slots. Coils wound into Al channel. SC wire has additional insulation. Al coil channels at ends connected to the outer Al shell.

Quadrupole Magnetic Field (1)

Yoke field

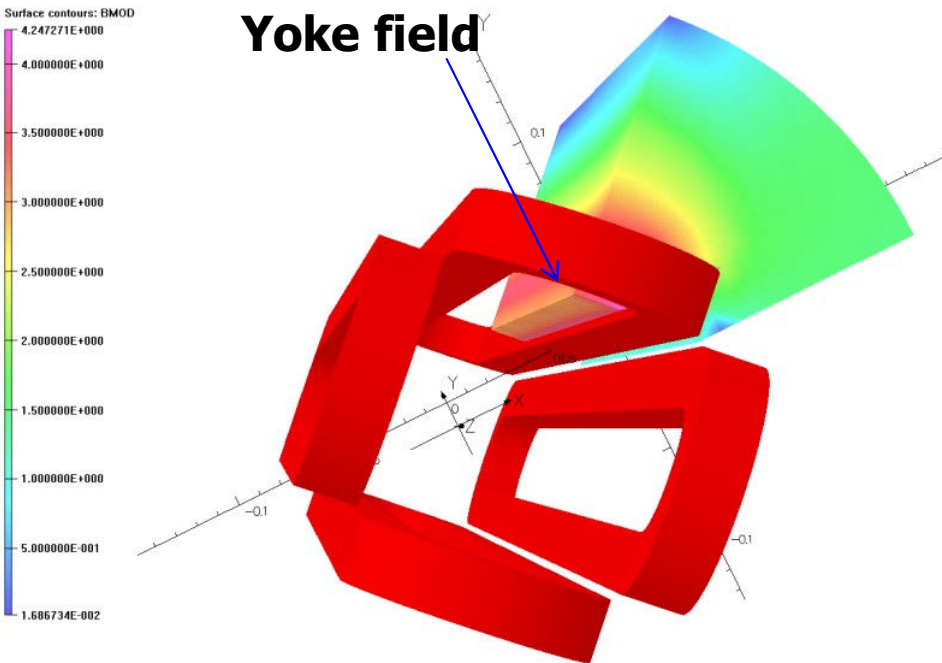

Coil field

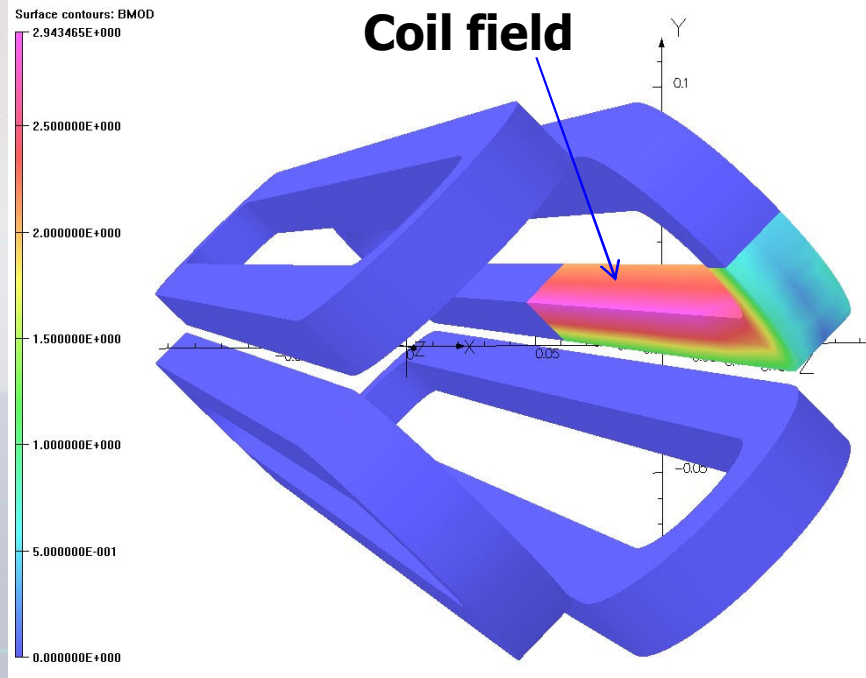

Splittable Quadrupole SP_80kA_MI_021510a.op3

IW=80 kA	a t 0.005m		INT(G*L),T
0	0.005	0	0.098679
0.087266	0.004981	0.000436	0.098681
0.174533	0.004924	0.000868	0.098684
0.261799	0.00483	0.001294	0.098689
0.349066	0.004698	0.00171	0.098694
0.436332	0.004532	0.002113	0.0987
0.523598	0.00433	0.0025	0.098706
0.610865	0.004096	0.002868	0.098711
0.698131	0.00383	0.003214	0.098715
0.785398	0.003536	0.003536	0.098717

Angle	$0.5 \cdot B \cdot L_{eff}, T$	ETA
0	0.098679	0
5	0.098681	2.03E-05
10	0.098684	5.07E-05
15	0.098689	0.000101
20	0.098694	0.000152
25	0.0987	0.000213
30	0.098706	0.000274
35	0.098711	0.000324
40	0.098715	0.000365
45	0.098717	0.000385

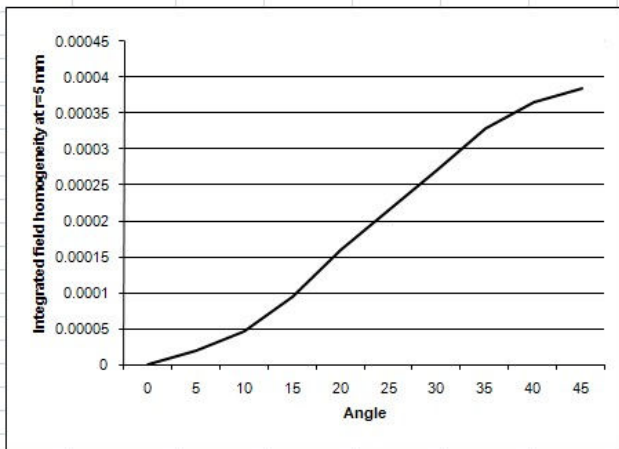

Peak field 4.3T is at the pole ends.
 Coil peak field is 2.9 T.
 Integrated gradient at 80 kA total coil current is 39 T.
 Integrated gradient homogeneity at R=5 mm is 4 units.

Magnet pole

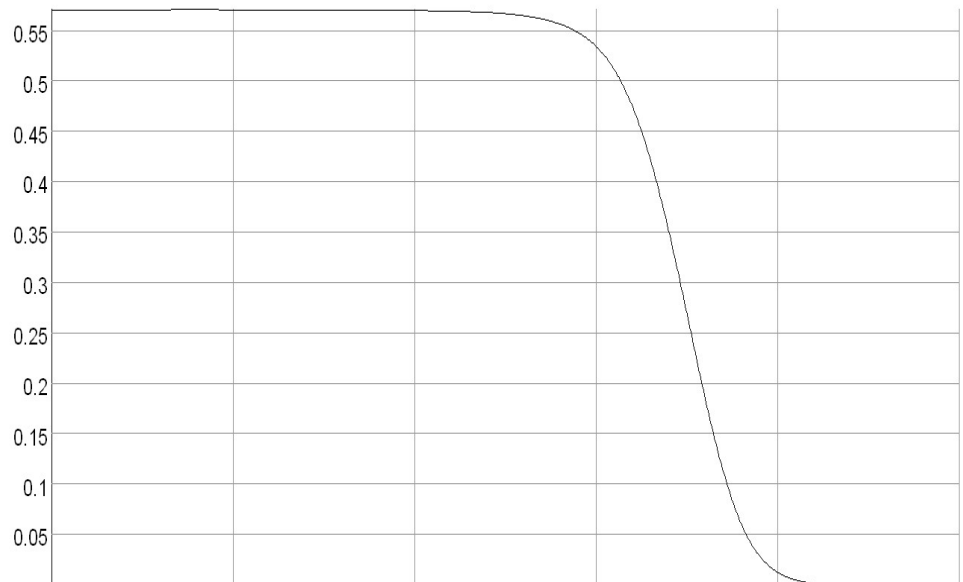

X coord 0.01 0.01 0.01 0.01 0.01 0.01
 Y coord 0.0 0.0 0.0 0.0 0.0 0.0
 Z coord 0.0 0.1 0.2 0.3 0.4 0.5

Component: BMOD, from buffer: Line, Integral = 0.19730727991169

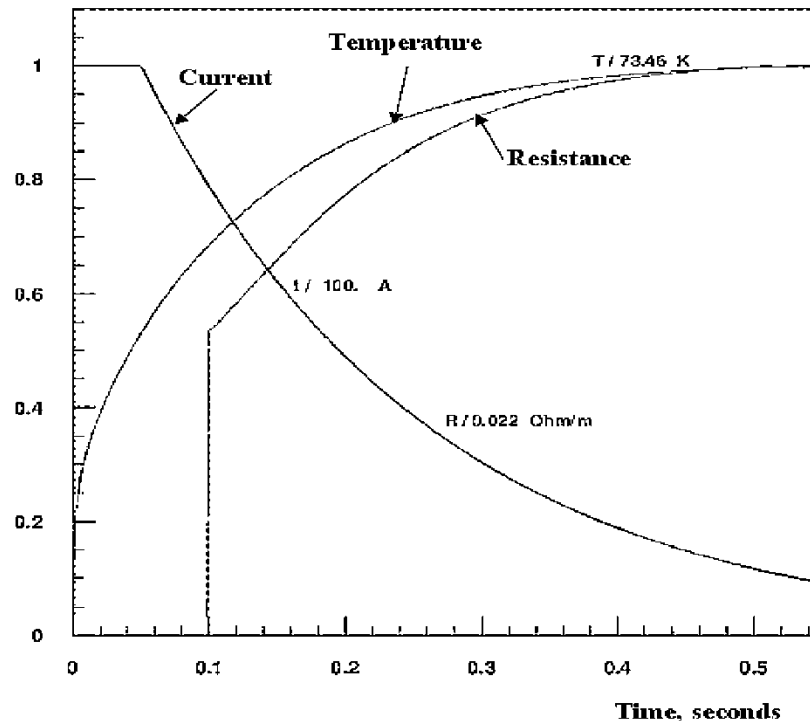

Field Bmod (T) along Z-axis at X=1cm, Y=0.

Coil peak temperature after the quench is 73 K. Energy of magnetic field is 40 kJ.

Quadrupole Cooling-Down

- The quadrupole will be cooled using conductive cooling.
- Five heat transfer leads will thermally connect quadrupole Al shell and LHe supply line. The cross-section of leads 50 mm x 10 mm;
- The quadrupole Al shell will be also in a good thermal contact with 300 mm dia. He return line.
- Cooling down time for the whole cryomodule is 30 Hours.
- During cooling initially the cold He gas goes through supply and return lines and temperature changes from 300 K to 2 K. In such regime the enthalpy of the cold gas between 4.2 K and 300 K is utilized as well.
- To cool down 1 kg steel from 300 K to 2 K is needed to evaporate 0.8 liters of LHe.
- The quadrupole mass is \sim 280 kg.

Conductive Cooling Animation

1

NODAL SOLUTION

TIME=2375
TEMP (AVG)
RSYS=0
SMN =293.494
SMX =299.884

ANSYS

APR 13 2009
10:44:11

**Quadrupole cooled
down from 300K
to 3.5K in 38
hours.**

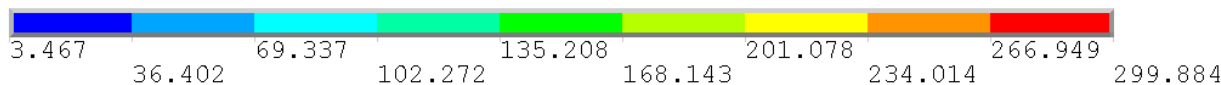
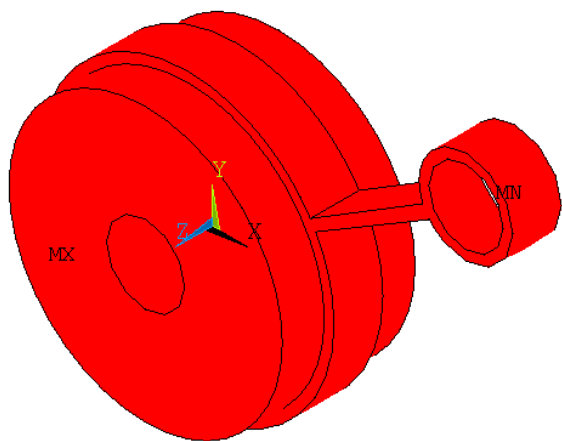

Quadrupole Magnet Cooling Demo

Quadrupole Package Modifications

- **The quadrupole structure must be mechanically stable to avoid magnetic center shift during excitation.**
- **Current leads between cold mass and leads LHe tank should be modified to provide operation in a conduction cooling mode.**
- **Easy magnet assembly and disassembly.**
- **Modify the coil bobbins for better conduction cooling.**
- **Improve superconducting wire electrical insulation mechanical properties.**
- **Provide good thermal passes from coils and core to the LHe supply line.**
- **Provide coil temperature monitoring.**



HGQ01 Quadrupole Parts

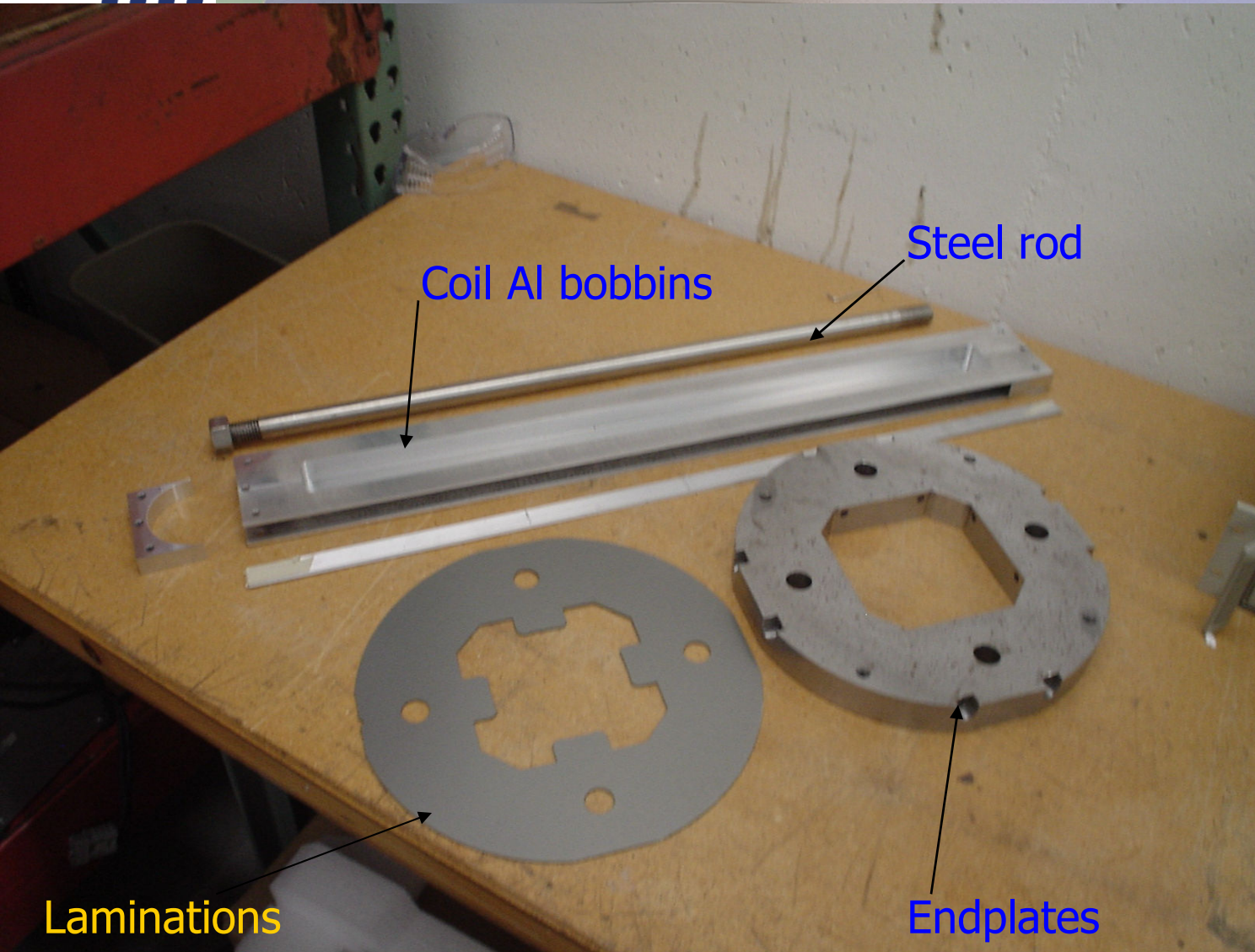

**There is enough
0.5 mm dia.
superconductor
to wind new
magnet coils.**

HGQ01 Quadrupole Modifications

Split plane

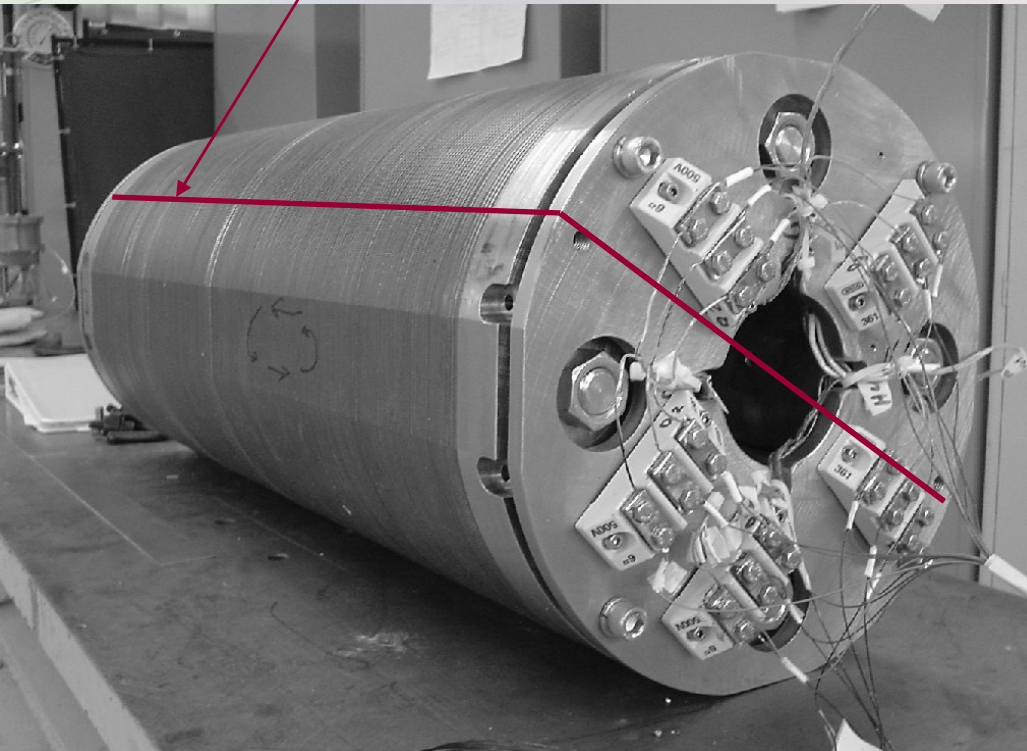

- Quadrupole laminated yoke consists of two halves;
- Laminations laser cutted with accuracy 20 microns;
- Long calibrated rods connect two thick side plates and laminations in the solid unit;
- Two coils mounted in each half core.
- There is an easy access to provide accurate coil mounting relatively pole and provide the coil frame prestress;
- The half units identical and exchangeable;
- All current leads should be heavily stabilized with extra copper material.

Quadrupole Wiring Scheme Modification

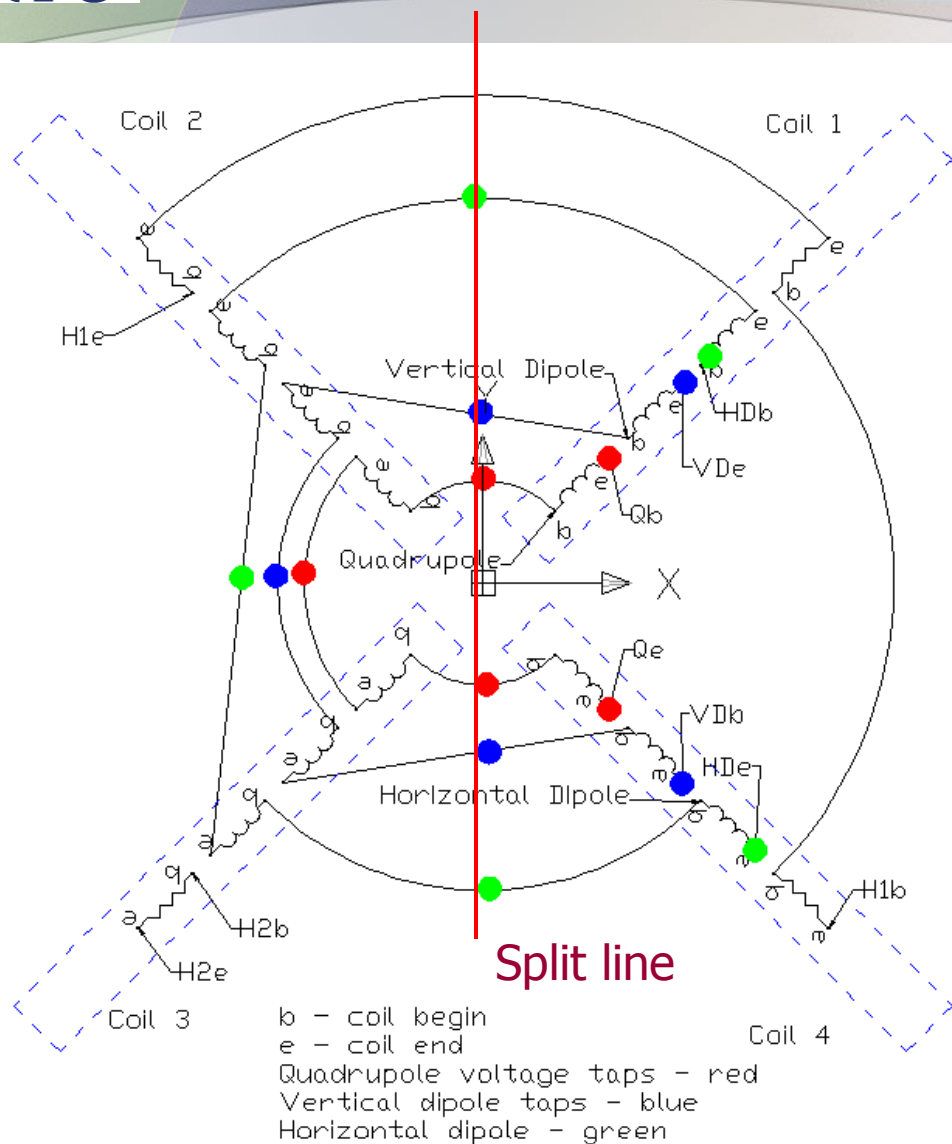

Quadrupole consists of 4 coils.

Each coil has 3 sections of NbTi superconductor: one is for quadrupole and two for vertical and horizontal dipoles.

There is also heaters in each coil wound from a stainless steel wire.

Quadrupole and dipole sections connected in quadrupole and dipole configuration as shown in figure.

The connections easy to rearrange for split configuration

New Quadrupole Cold Mass

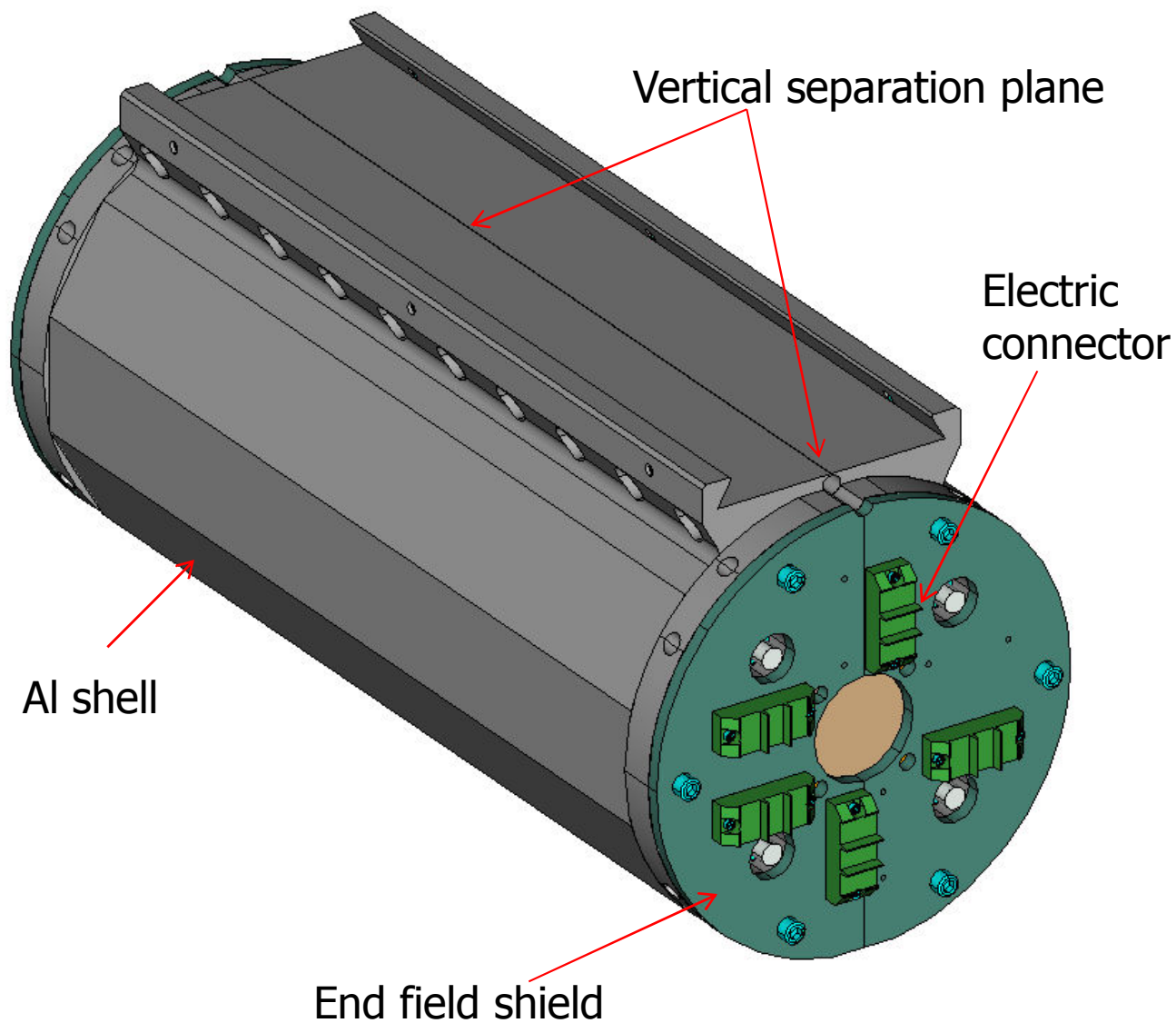

Quadrupole Exploded View

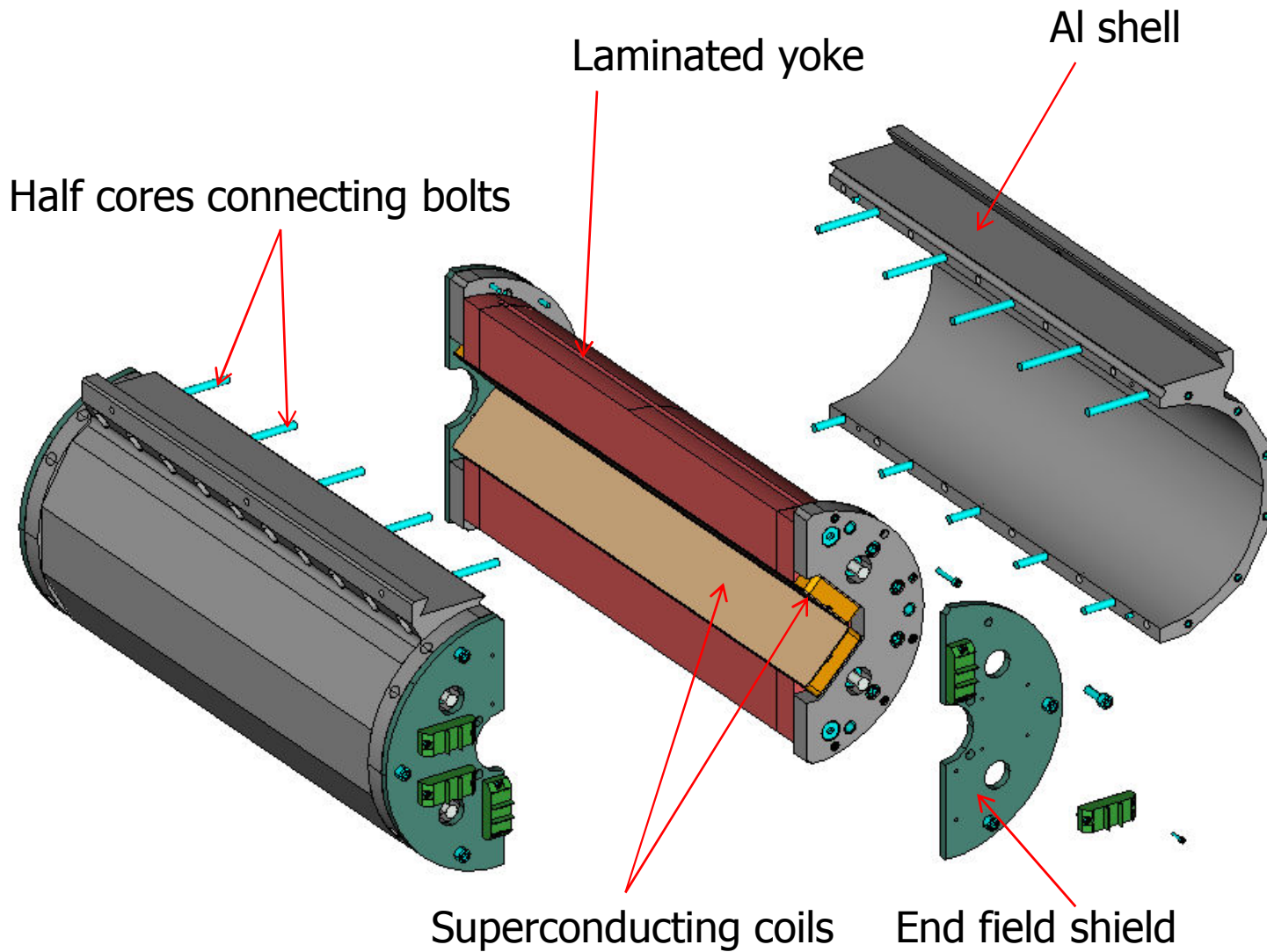

Half of Iron Yoke Assembly

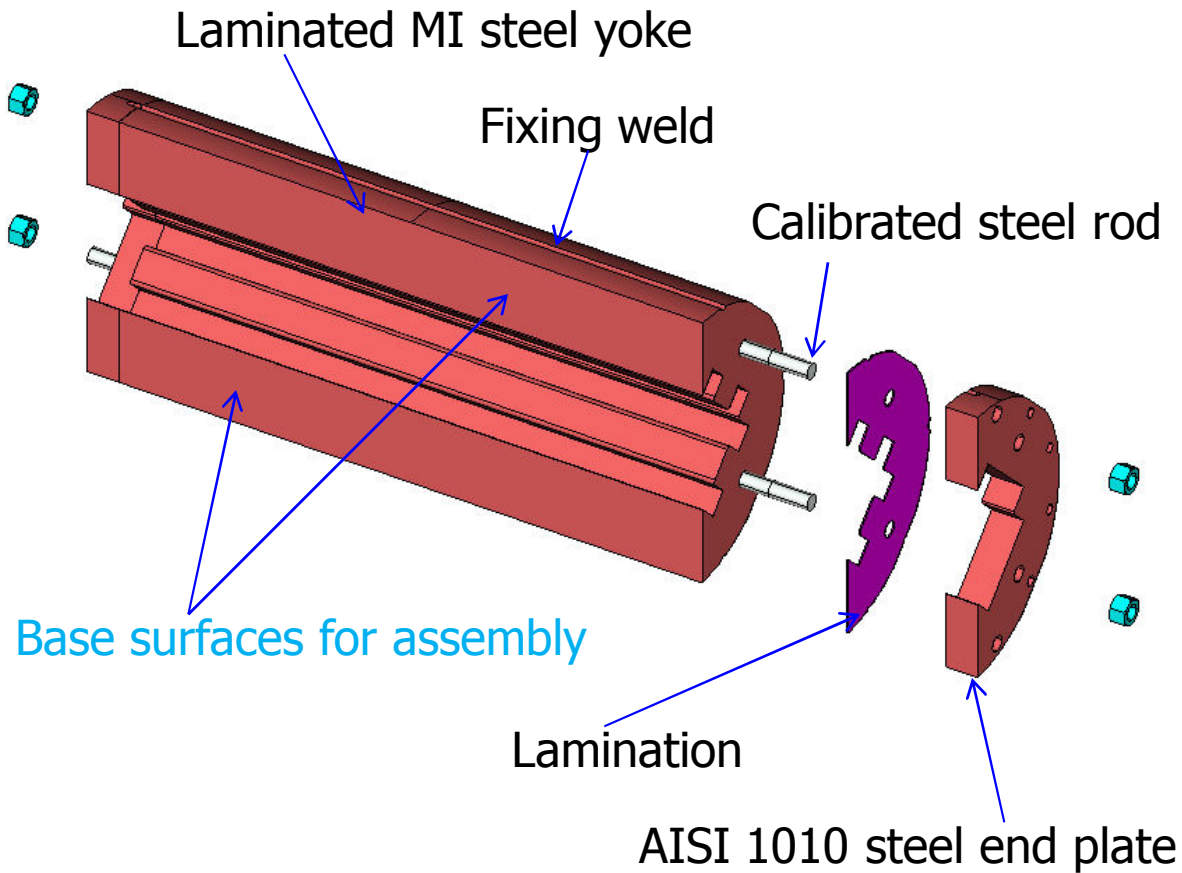

The yoke laminations are laser cut from MI low carbon 1.5 mm thick steel. The half core is assembled in the FNAL IB2 horizontal press. Calibrated rods and base surfaces provide package straightness. Final mechanical rigidity provided by fixing welds.

Half Yoke with Al End Plate

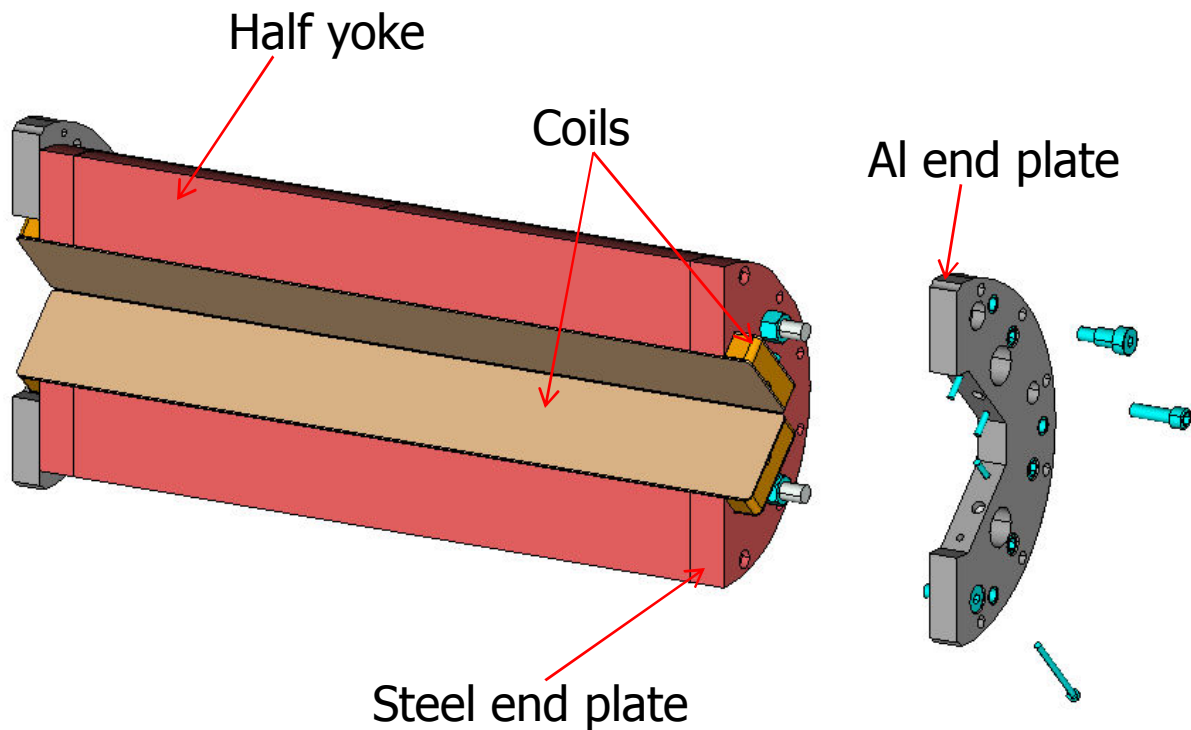

Al end plate mechanically and thermally connected to the coil and outer shell Al collars providing better thermal conductivity between coils and cooling tube.

Quadrupole Lifting and Positioning

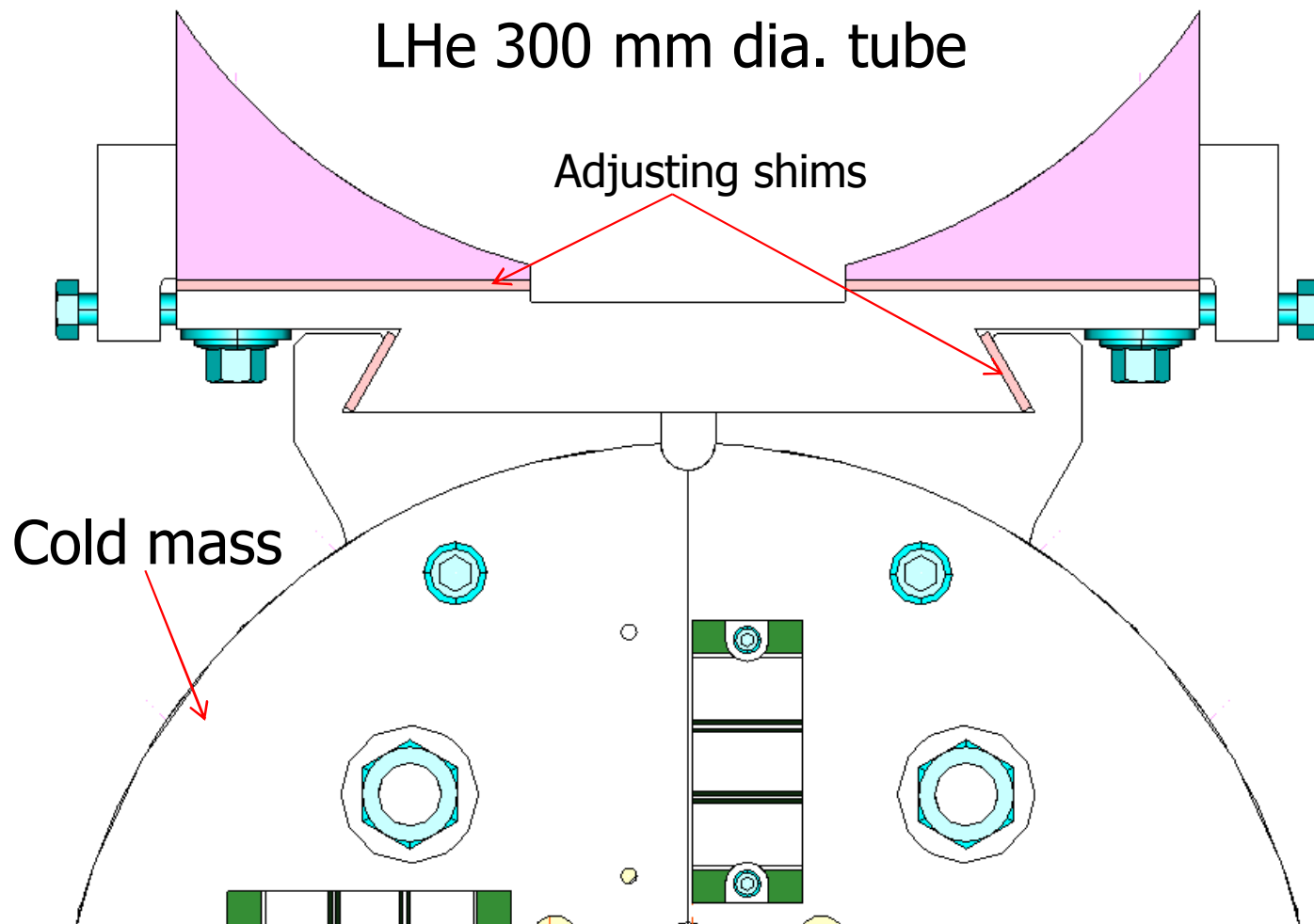

Superconducting Coil

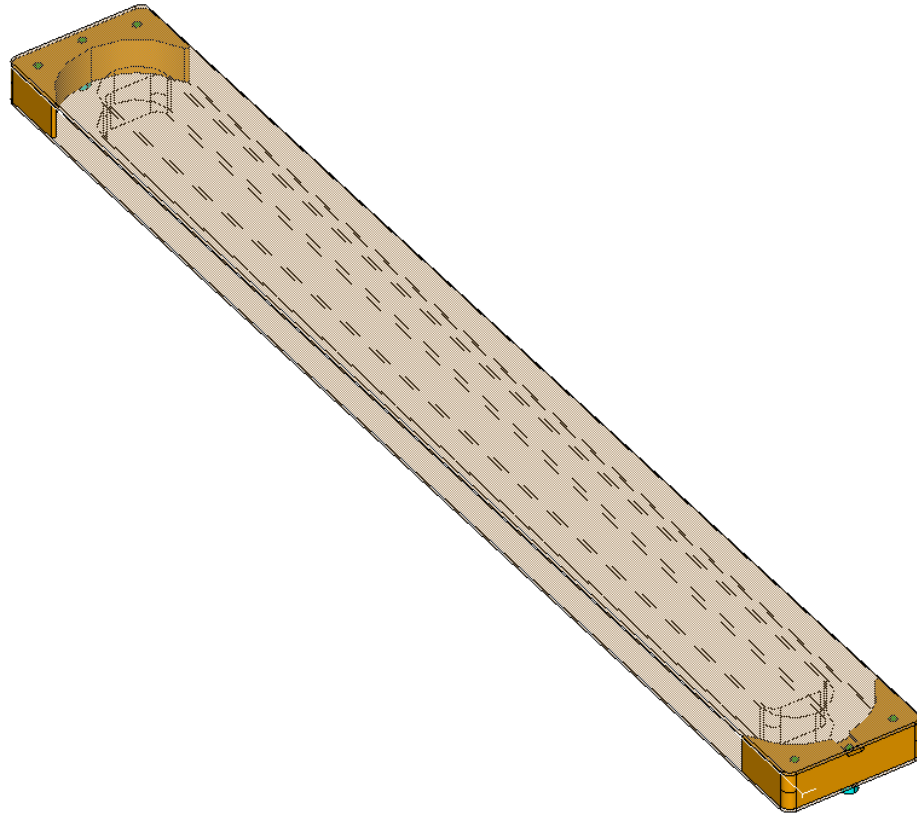

The coil is wound inside Al channel. The 0.5 mm dia. NbTi wire has enamel insulation and additional layer of glass fiber. The coil assembly is vacuum impregnated with epoxy. The coil leads are soldered to more strong conductively cooling leads.

Coil has 800 turns with peak current 100 A.



Superconductor Choice

NbTi wire diameter, mm	0.5
Number of filaments	7242
Filament diameter, um	3.7
Copper : Superconductor	1.5
Insulated wire diameter, mm	0.54
Enamel insulation	Formvar
Wire diameter with an additional glass fiber insulation, mm	0.58-0.64
Twist pitch, mm	25
RRR of copper matrix	100
Critical current I_c @ 4.2K, at 5T	204 A

- Superconductor type NbTi – well known technology and cost efficient at specified fields
- Small filament size $< 5 \mu\text{m}$ achievable to reduce superconductor magnetization effects
- Diameter 0.3-0.5 mm for currents $\leq 100 \text{ A}$ to reduce heat load from current leads and cables from power supply
- Cu:Sc ratio $\sim 1.5-2$ to provide safe quench protection
- RRR 50-100 to improve superconductor stability and quench parameters
- Efficient electrical insulation: polyimide, formvar, etc

Quadrupole Inside Cryomodule

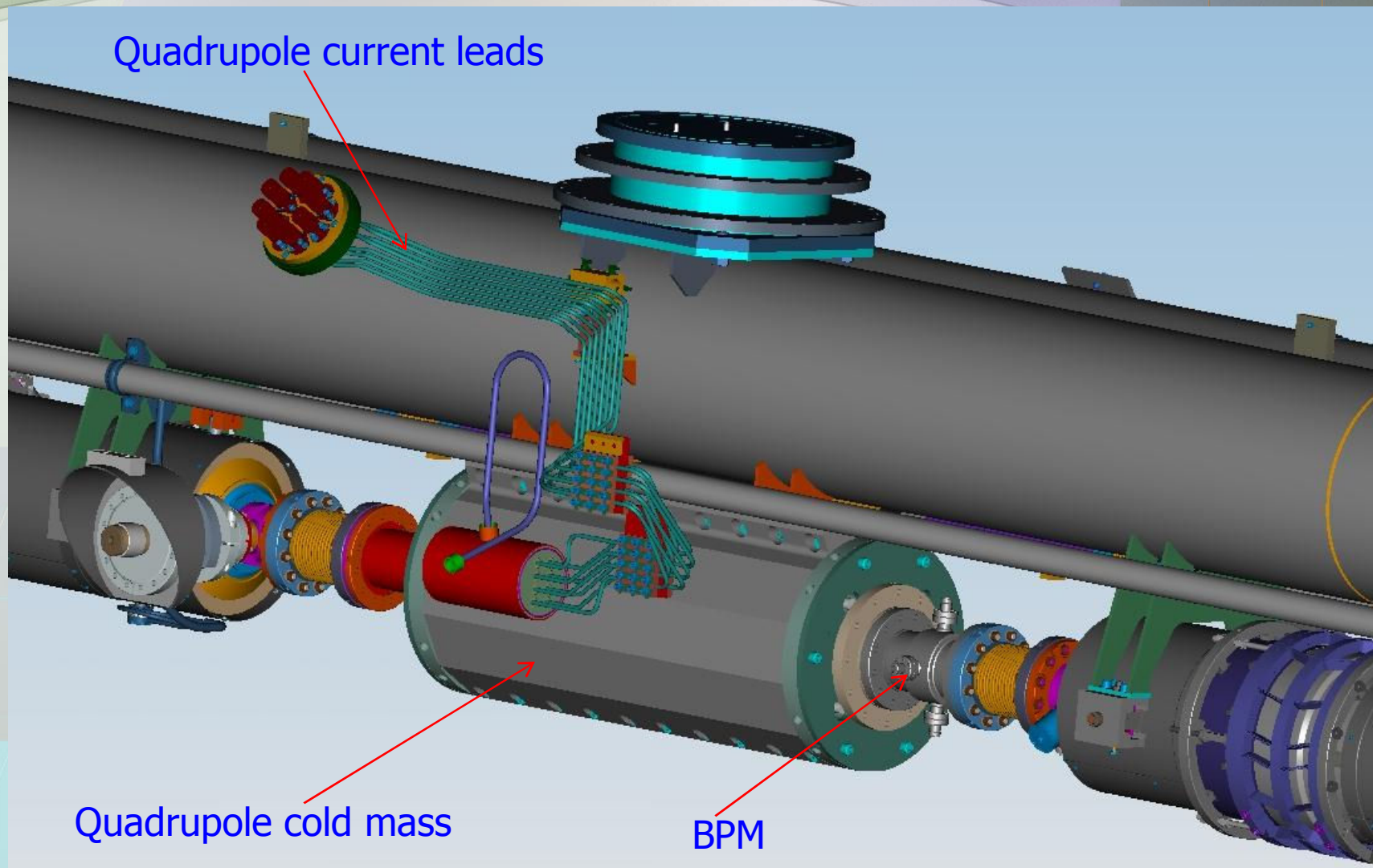

Quadrupole Cross-Section

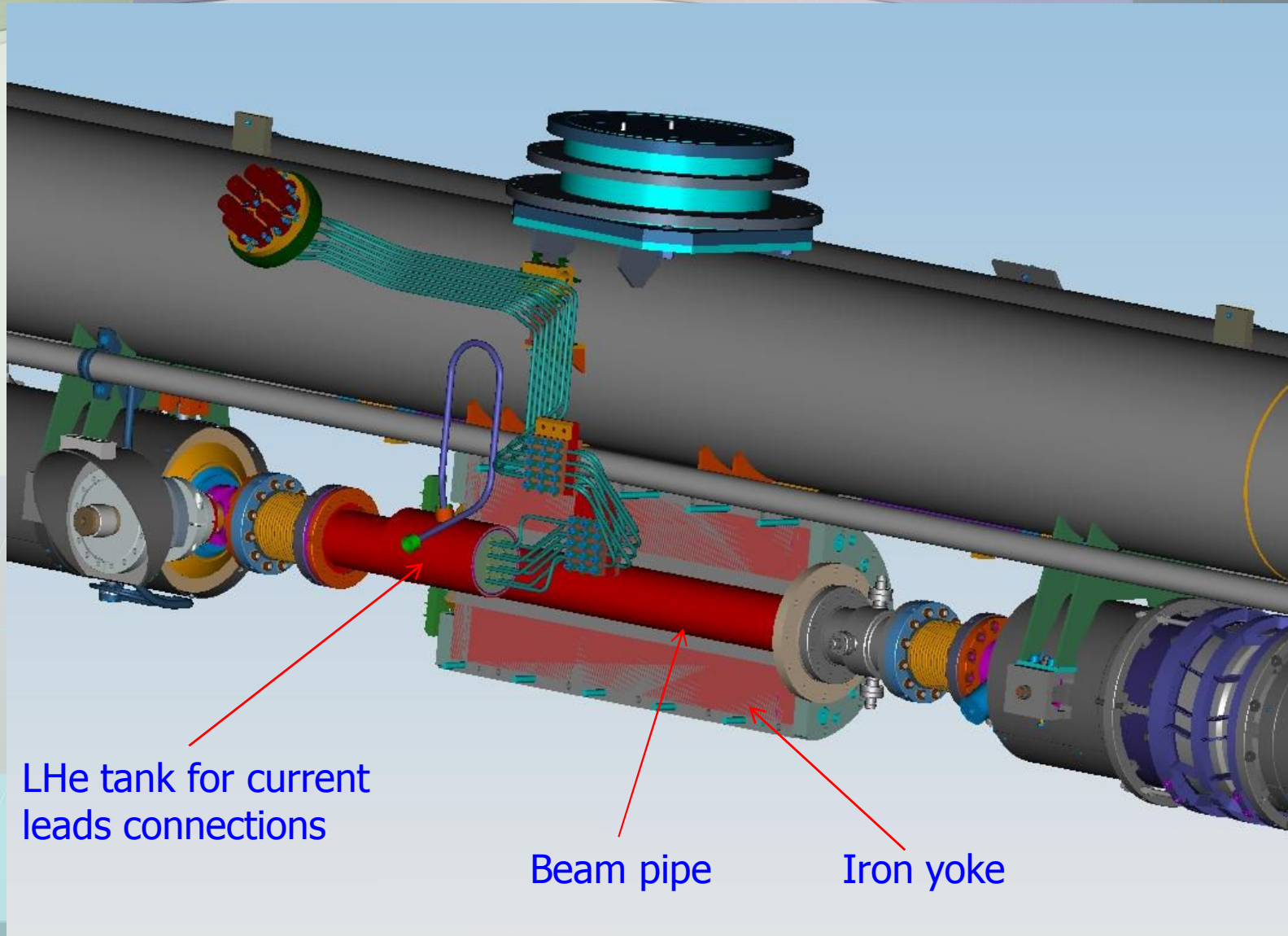

Possible modification

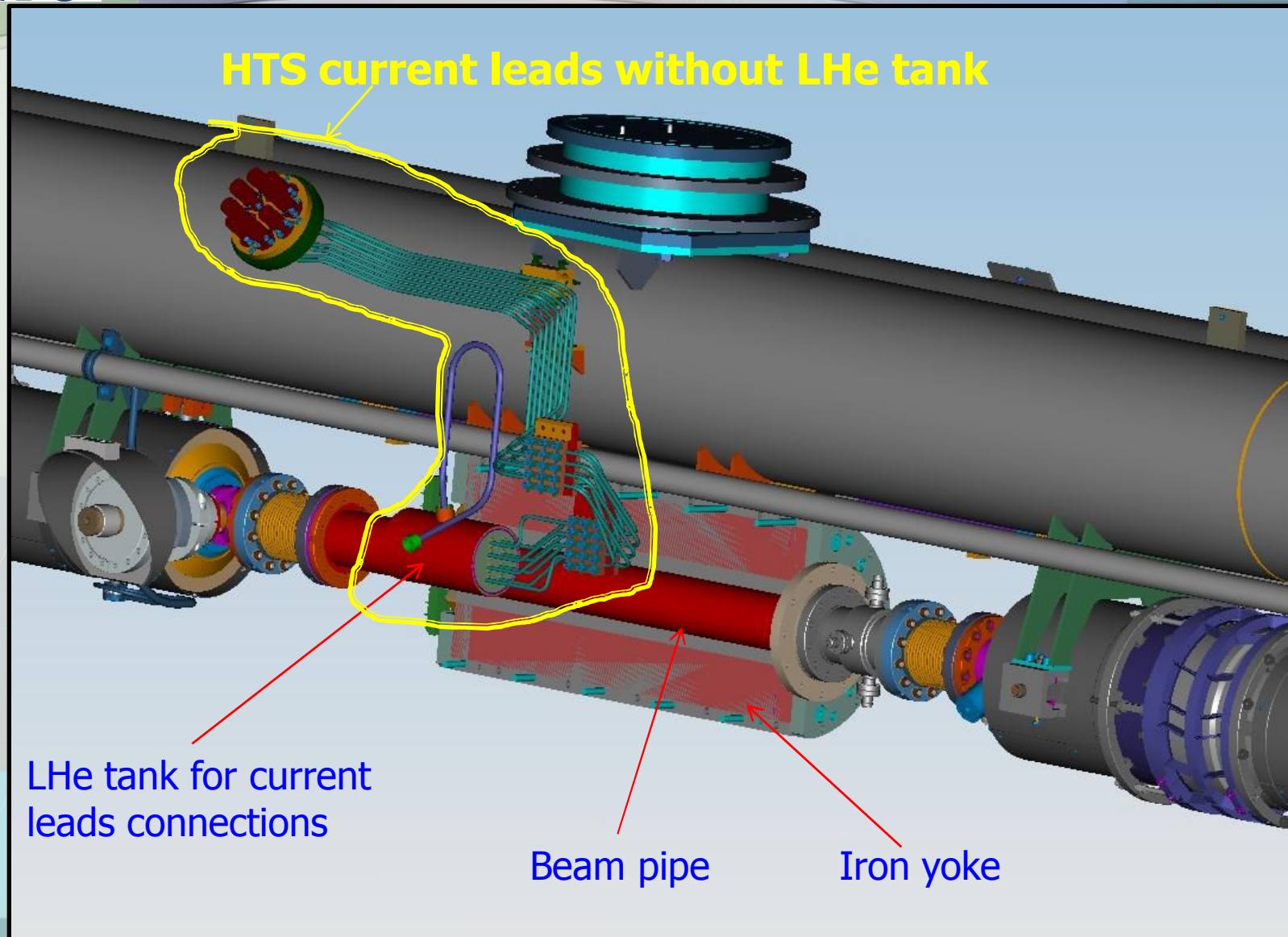

Cryomodule Before Quadrupole Installation

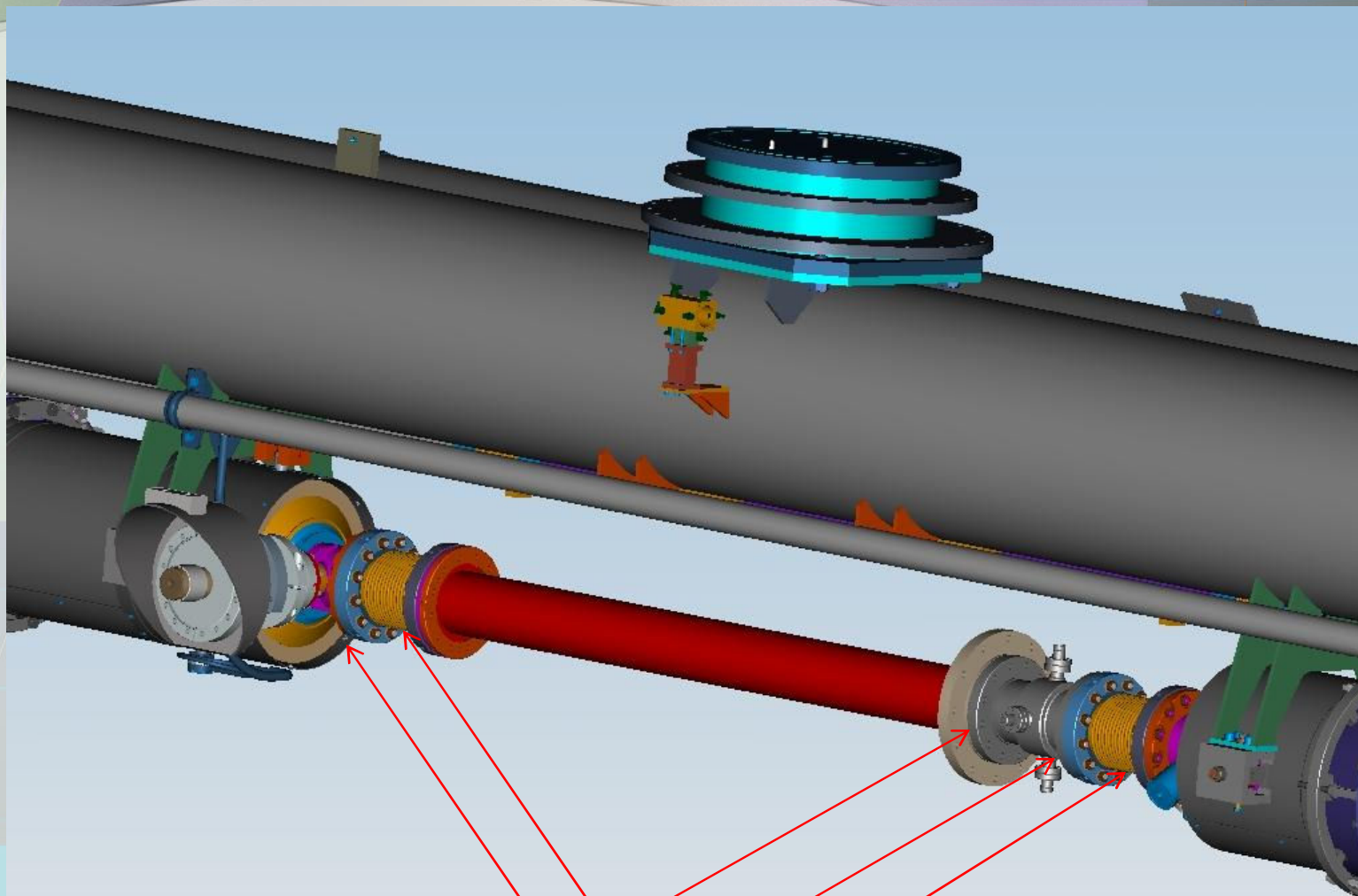

All beam pipe connections made inside the clean room

Cryomodule Cross-Section

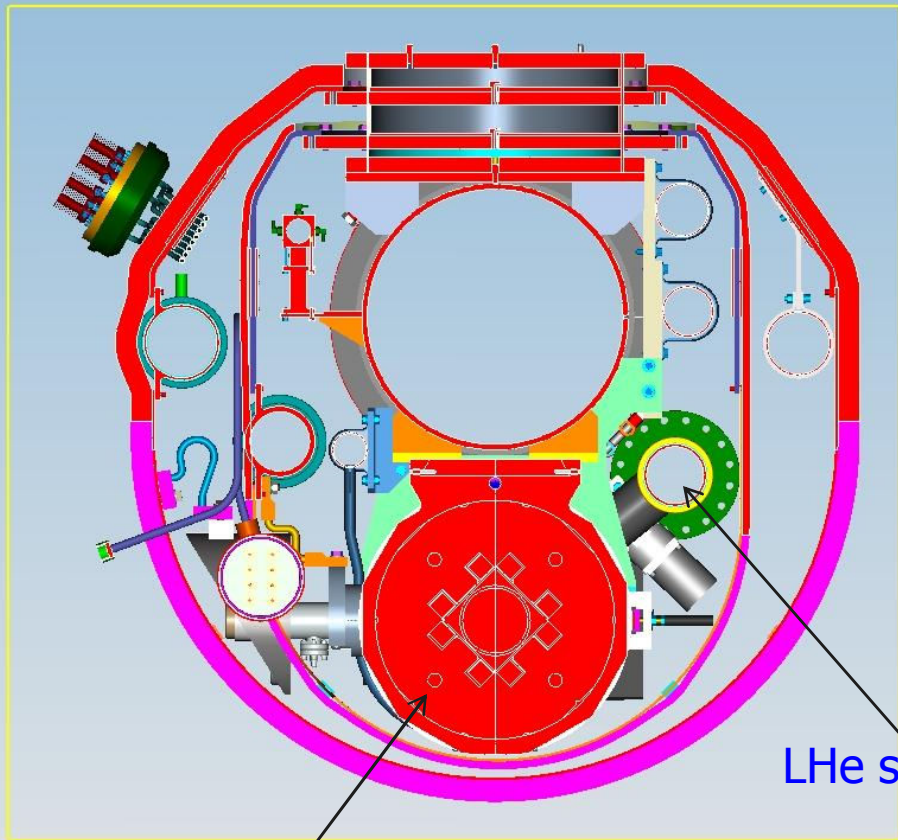

Quadrupole cold mass

LHe supply pipe

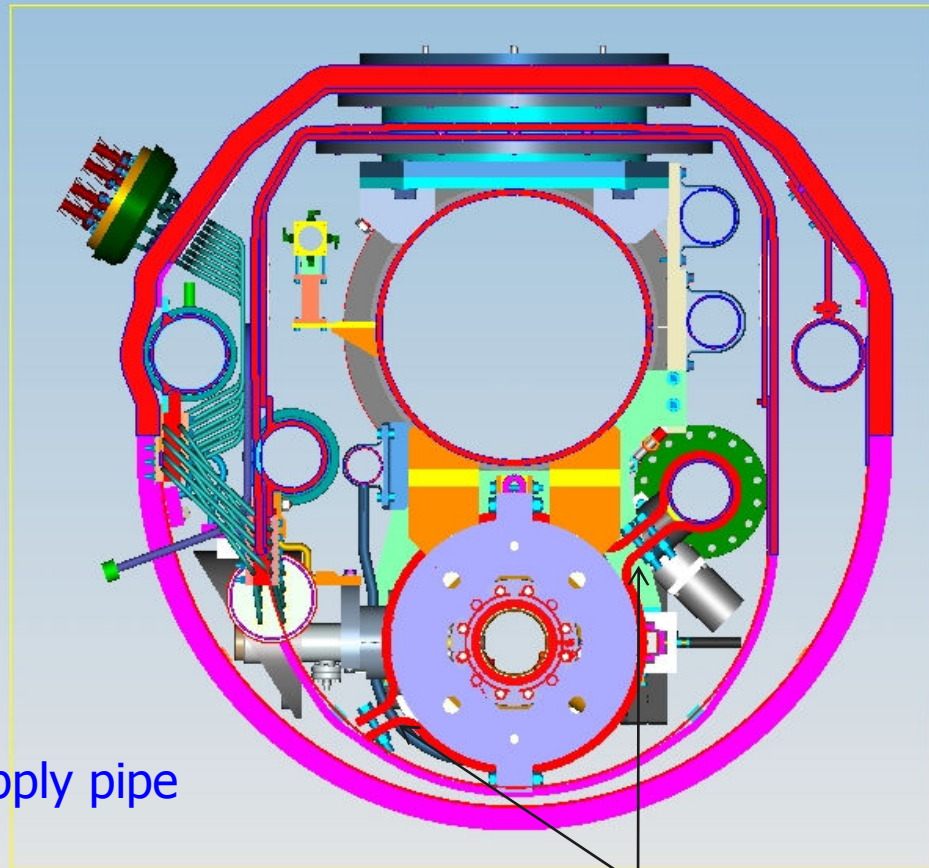

Thermal leads to LHe supply pipe



Splittable Quadrupole FY10 Schedule

1	Cryogen Free Splittable Quadrupole, March 2, 2010												
2	Month	Jan	Feb	Mar	Apr	May	June	July	Aug	Sep	Oct	Nov	Dec
3	Quadrupole												
4	Magnetic design	■	■										
5	Mechanical design	■	■										
6	Thermal design	■	■										
7	Quadrupole drawings	■	■	■									
8	Cryomodule integration drawings		■	■	■								
9	Tooling drawings			■	■								
10	Superconductor glass fiber insulation			■	■								
11	Laser cut laminations			■	■	■							
12	Parts procurement			■	■	■	■	■					
13	Coil fabrication					■	■	■	■	■			
14	Quadrupole assembly									■	■		
15	Quadrupole test in VMTF (bath cooling)											■	■



Splittable Quadrupole FY10 Resources

Labor resources needed:

- Designer/drafter (C. Cronson) is employed to work at the ILC magnet package design.
- Proposal is to hire new technician and redistribute labor between IB2 technicians (G. Velev-manager, A. Makarov-fabrication engineering support) to manufacture this quadrupole.
- TD/SCRF Dept. – integration with Cryomodule (Y. Orlov)
- TD/MSD/HFM/Eng. – magnet design and engineering support (N. Andreev, V. Kashikhin)
- TD/MSD/Measurement group – test and magnetic measurements (M. Tartaglia, G. Velev)
- TD/Test Dept. – magnet mounting for test in VMTF, cryogenics, instrumentation, stand operation.



First Quadrupole Model M&S

	A	B	C	D	E	F	G	H	I	J	K	L
1	P/N	Description	Qty Per	Qty Ord.	Cost per	Total	PO	Vendor	Del	Rec'd	Comment	Cost,\$
2	MD 442830	Magnet Assembly										
3	MD 442698	Coil Assembly	4									
4	MB 442801	End Plate	2	4	\$365.21	\$1,460.84	575230	J Marcs	6/28/07	6/29/07	IB3	
5	MA 442869	Terminal Block 3 Circuit	5	50	\$7.90	\$395.00	PRN93351	Allied Electr	8/6/07	8/6/07	Matt	
6	MA 442828	HHCS, M6 x 90mm lg 18-8	16	40	\$19.05	\$38.10	PRN92319	McMaster	5/16/07	5/16/07	IB3	
7	MA 393396	Nut, M6 x 1 18-8 SS	8					IB4				
8	MA 442831	HHCS, M10 x 30mm lg 316	8	20	\$13.58	\$27.16	PRN92319	McMaster	5/16/07	5/16/07	IB3	
9	MA 442862	Pan Head Screw, M4 x 10mm	10	100	\$6.03	\$6.03	PRN92319	McMaster	5/16/07	5/16/07	IB3	
10	MA 442705	Coil Wire	618M	2384'	\$14.26	\$57.04		McMaster	5/16/07		T. Wokas Has	
11	MA 442706	Heater Wire	1.7M									
12	MA 106778	Tape, Kapton, 1" w adhesive	3M	0	\$0.00	\$0.00		IB4				
13	MA 116511	Tape, Fiberglass 1" w	2M	0	\$0.00	\$0.00		IB4				
14	Weco#361	Terminal Block (min 50pcs)	10	50	\$7.90	\$395.00	PRN93351	Allied Electr	7/10/07	8/6/07	Matt	
15												\$2,379.17
16	MB 442805	Yoke Assembly	1									
17	MB 442794	Yoke Lamination	500	1000	\$1.39	\$1,390.00	575574	LAI	7/6/07	10/18/07		
18	MB 442795	Yoke End	2	4	\$611.36	\$2,445.44	575230	J Marcs	6/28/07	6/29/07	IB3	
19	MB 442800	Alignment Rod	8	16	\$186.00	\$1,488.00	MSH 2305	HRMS	5/31/07	6/15/07	IB3	
20		Rod, Prec Ground 3/4" dia	8	8	\$53.75	\$430.00	PRN92319	McMaster	5/16/07	5/16/07	Marty	
21	MA 439357	Nut, 3/4-10 300 Series	8	16	\$11.68	\$186.88	PRN92319	McMaster	5/16/07	5/16/07	Marty	
22												\$4,638.32
23												
24	MD 442698	Coil Assembly										
25	MB 442699	Channel Assembly	8		\$274.65	\$2,197.20	574274	Hi Grade	4/23/07	5/17/07	Vladimir IB3	
26	MB 442701	Coil Channel End	16		\$69.00	\$1,104.00	574274	Hi Grade	4/23/07	5/3/07	Vladimir IB3	
27	MB 442703	Coil Channel Side	16		\$105.00	\$1,680.00	574274	Hi Grade	4/23/07	5/8/07	Vladimir IB3	
28												
29	MB 457097	Corr. Coil Wind Tool Assy	1			\$761.25	575922	Hi Tech	7/16/07	7/19/07	IB3	
30												
31	MA 457128	Tape, Alum 1 x .007 x 5yds	4		\$7.82	\$38.28	PRN94626	McMaster	7/16/07	7/16/07	IB4 Stk	
32												
33	MB 457414A	Coil Channel	8		\$357.56	\$2,860.48	576919	J Marcs	9/18/07	9/27/07	IB2	
34	MB 457428A	Coil Channel Side	16		\$32.94	\$527.04	576919	J Marcs	9/18/07	9/27/07	IB2	
35	MB 457429A	Coil Channel End	16		\$41.02	\$656.32	576919	J Marcs	9/18/07	9/27/07	IB2	
36												
37	MA 457638	Clevis Pin & Retaining Ring	20			\$28.60	PRN99334	McMaster	11/2/07	11/2/07	IB2	
38	MB 457765	Aligment Rod	8			\$124.00	MSV 2402	VMS	12/7/07	12/7/08	IB2	
39	MB 457800	Yoke End V2	4			\$2,418.00	MSV 2402	VMS	12/7/07			
40		Center Grind Diameter	8		\$49.00	\$392.00	579218	Mar Fre	2/11/08	2/11/08	IB2	
41	4466K492	Tube, 3"OD x 2.87"ID x 3'	1			\$95.12	PRN92035	McMaster	5/10/07	5/10/07	Vladimir	
42			1			\$95.12	PRN92204	McMaster	5/15/07	5/15/07	Vladimir	
43	8860K62	Brass Nut, 3/8-24	50			\$25.90		McMaster			T Wokas	
44												
45	MD 459408	Bellows C-Clamp	2			\$897.00	MSV 2599	VMS	12/15/08	12/16/08	Oscar	
46												
47	SC-VSF-SSCI	Wire, Super. 0.5mm w/HML In12K meter			\$0.44	\$5,220.00	577310	Supercon	10/1/07	10/1/07	Vladimir	
48												\$19,120.31
49												
50											Total cost, \$	26137.8

Summary

- The splittable cryogen free quadrupole could be fabricated in FY10.
- Proposed the quadrupole with a vertical split and racetrack coils.
- The quadrupole set of drawings is released.
- Quadrupole has a conduction cooling from the LHe supply and return pipes.
- Quadrupole mounted around the beam pipe outside of a clean room.
- BPM has tight connection with quadrupole.
- Quadrupole bolted to the strong 300 mm diameter He return pipe.
- Special attention paid on the magnet assembly and mounting tolerances.
- Magnet cooling down time \sim 38 Hours.
- The magnet in 2010 only could be tested in TD/VMTF in a bath cooling mode.

VMTF Measurement System

The quadrupole first test could be made in VMTF which is quite busy. Only a bath cooled mode is possible. The rotational coil system with large number of sampling allows to reach accuracy $\sim 3 \mu\text{m}$. It was proved by HGQ01 model test.

- VMTF allows to test and measure:**
- Magnet training and quench current.
 - Quench detection and protection system.
 - Magnetic field harmonics in the bore.
 - Quadrupole effective length and integrated gradient.
 - Magnetic center shift at different currents with accuracy up to several microns.
 - Measurements at 4.2K and 2 K.

SLAC 4.2K Stand Relocation to FNAL



Cryostat 4.2 K LHe

**Power supplies
and control
system**



- **ILC Quadrupole Test Stand shipped from SLAC to FNAL and stored in Bld. 38.**
- **SLAC safety documentation is enclosed and will be reviewed.**
- **Commissioning ?**

FNAL SCRF 2K Test Stand

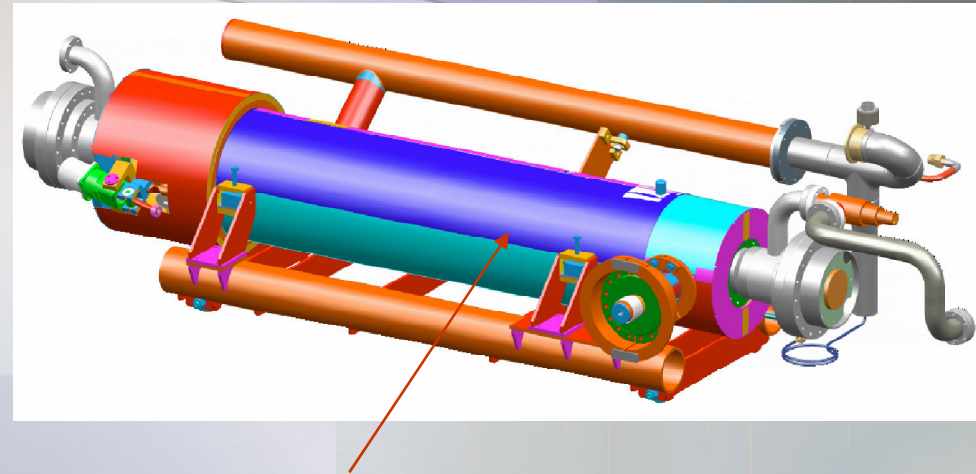
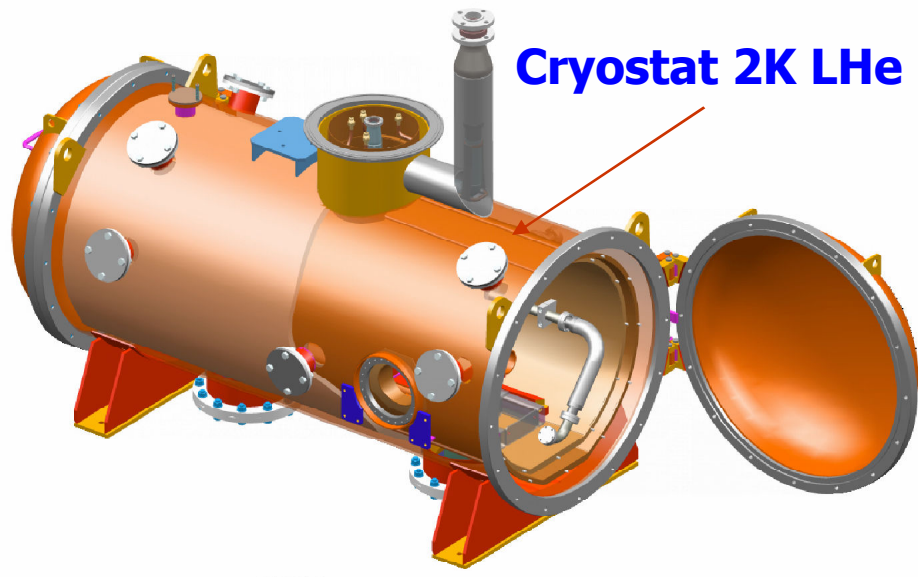

1.3 GHz cavity

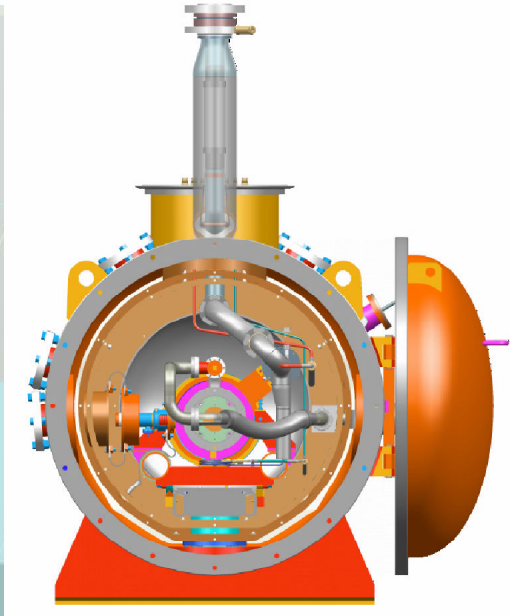

- FNAL SCRF Horizontal Test Stand (HTS) could be used for Quadrupole test in a conduction cooling mode at 2 K.
- Should be added 200 A current leads, instrumentation, and power supplies.
- For magnetic measurements should be added a room temperature bore.
- **Modernization of HTS or building new ?**