

1

ELEMENTS

ACEL

Total mass 1800 t

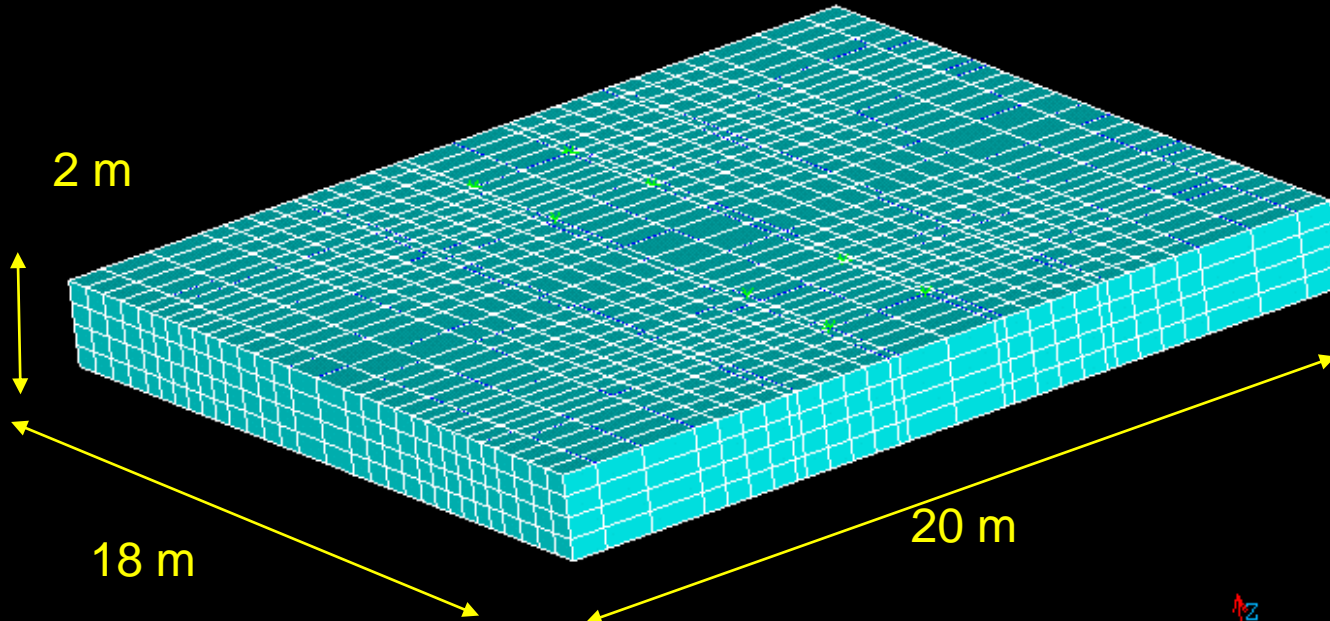

Reinforced concrete Slab

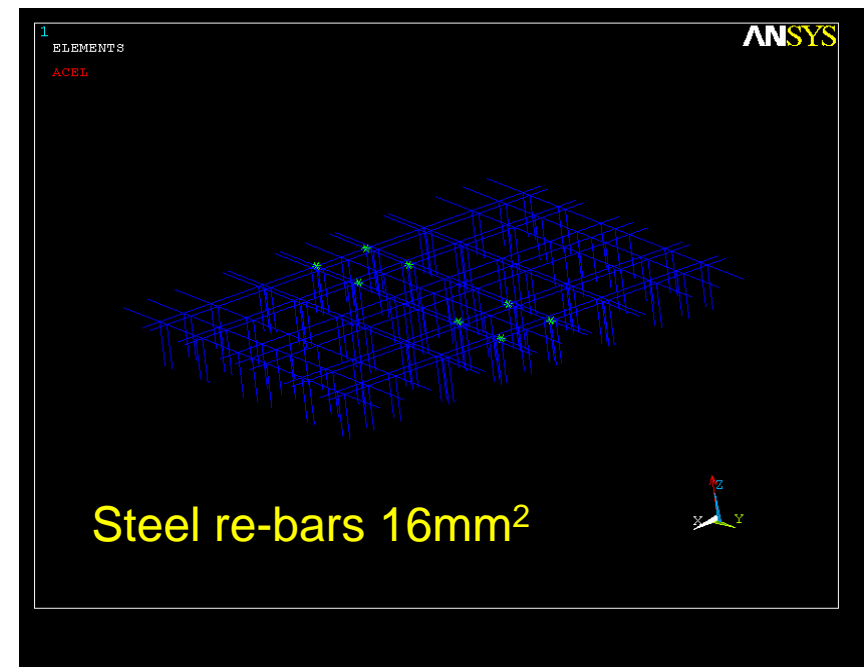
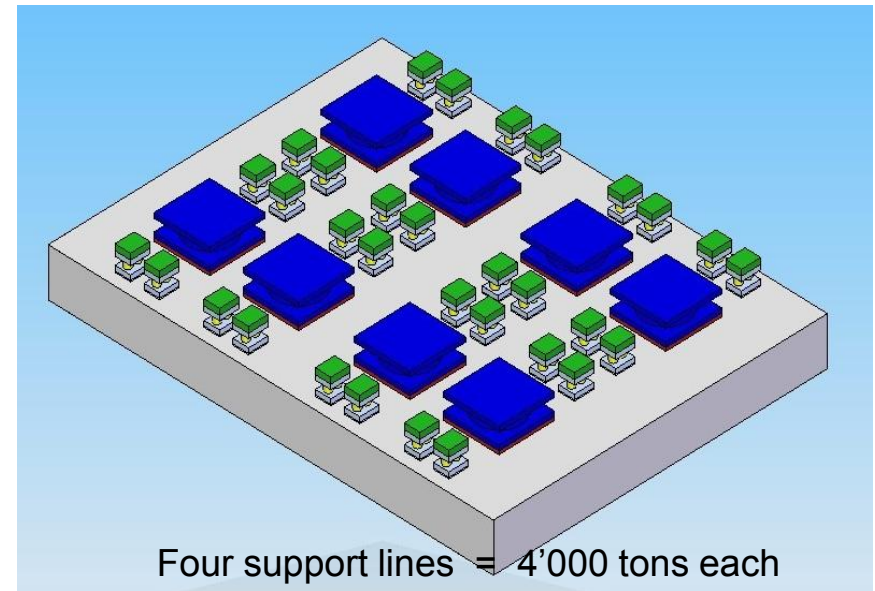
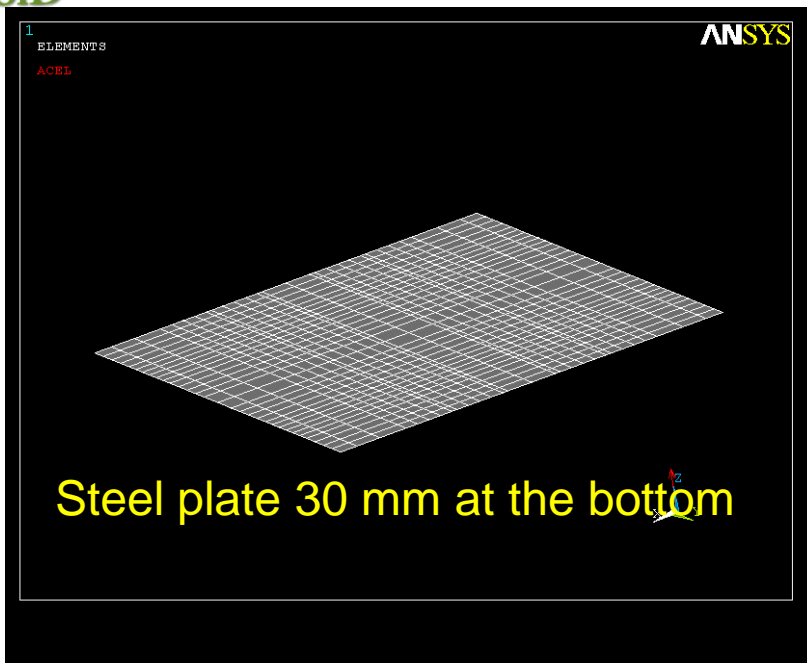

	Mass	Young modulus
Steel	85 tons	210 MPa
Concrete	1700 tons	14 MPa

Concrete micro-cracking
~ 2% internaal dumping

1

ELEMENTS

ANSYS

JUL 1 2010

10:10:36

Detector Weight 14'000 tons
as lumped mass elements with no stiffness

