

Modulator / Pulse Xfmr /
 Total Input Channel Count
 Fiber In : 9 (1 Spare)
 Latching Contact: 37 + 2?
 : (3 -2? Spares)
 Non Latch Contact: 2 (2 Spare)
 Pulse In : 2 (0 Spare)
 Latching Level In: 4 (4 Spare)
 Non Latch Level In: 1 (1 Spare)
 Analog Hi Z : 14 (2 Spare)
 Analog Lo Z : 11 (5 Spare)

Klystron High Voltage
 Total Output Channel Count
 Fiber Out : 5 (1 Spare)
 Contact Out : 7 (3 Spare)
 Level Out : 3 (3 spare)
 Analog Command Out : 2 (2 Spare)
 Analog Buffered Out: 2 (2 Spare)

Modulator / Pulse Transformer/ Klystron High Voltage / Solenoid Controls

17 MW Peak Power Modulator for These Klystrons
 Thales – TH2104C 5MW RF, TH1801 10MW RF
 Toshiba – E3736 10MW RF, E3740A 3MW RF
 CPI – VKL8301 10MW RF

Klystron High Power RF /Waveguide / Cavity Controls

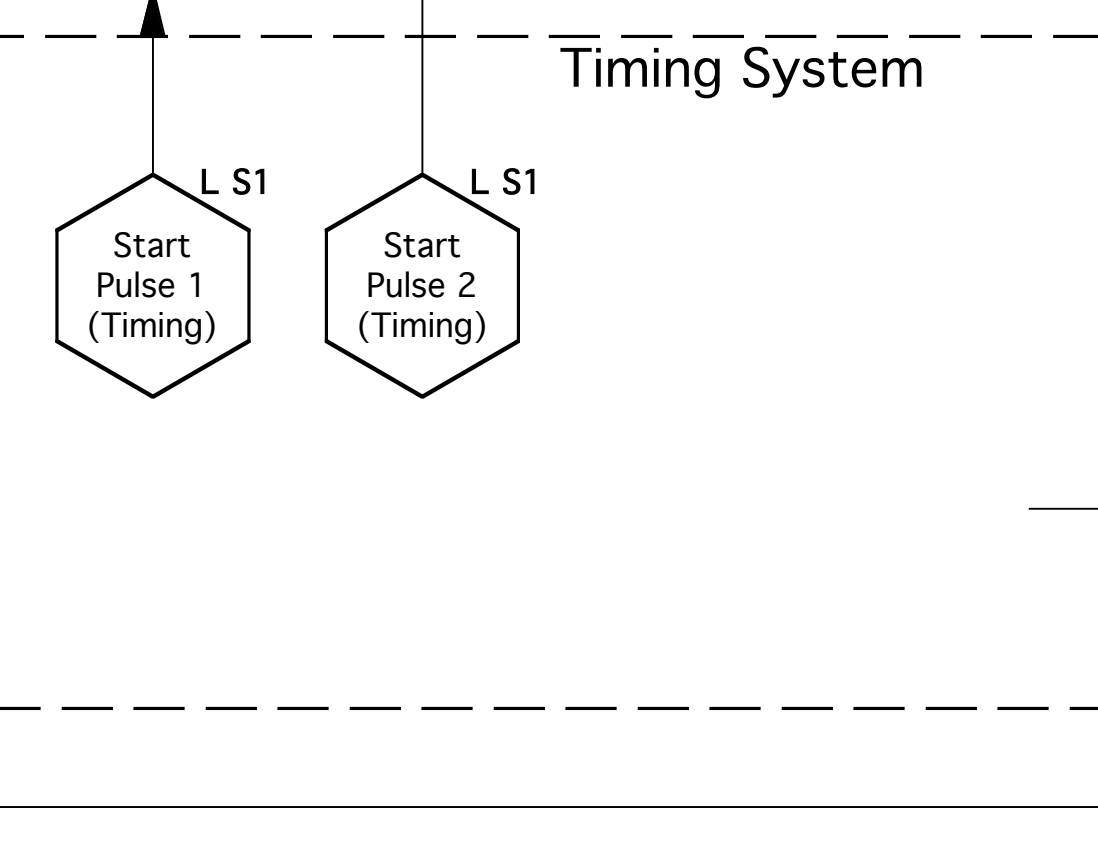
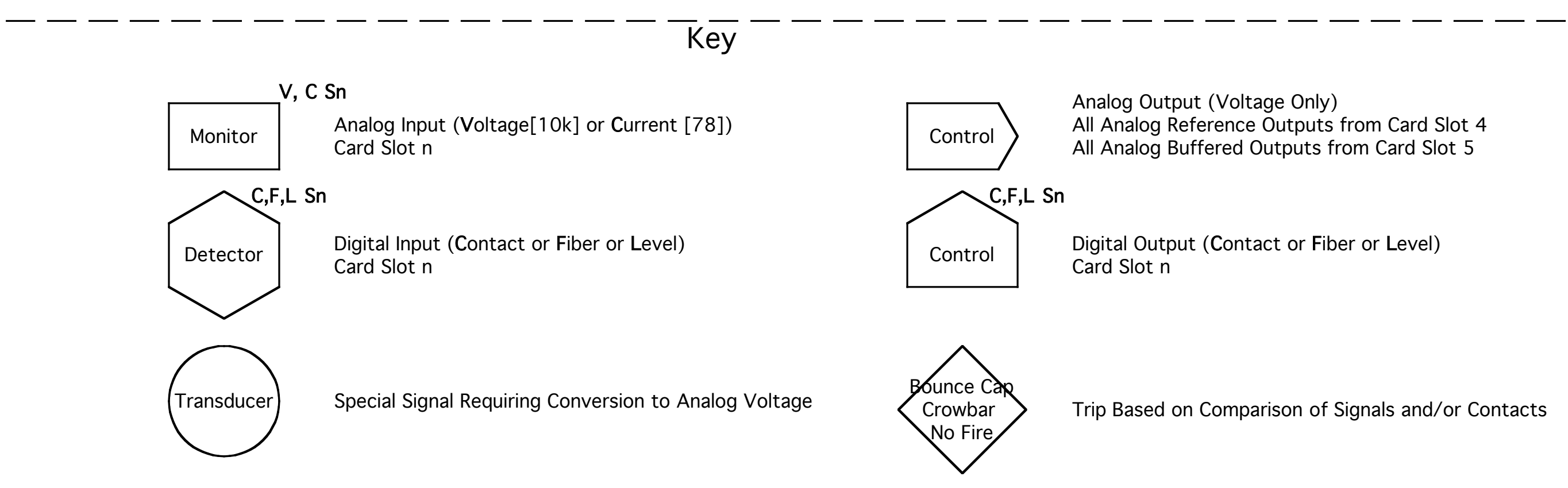
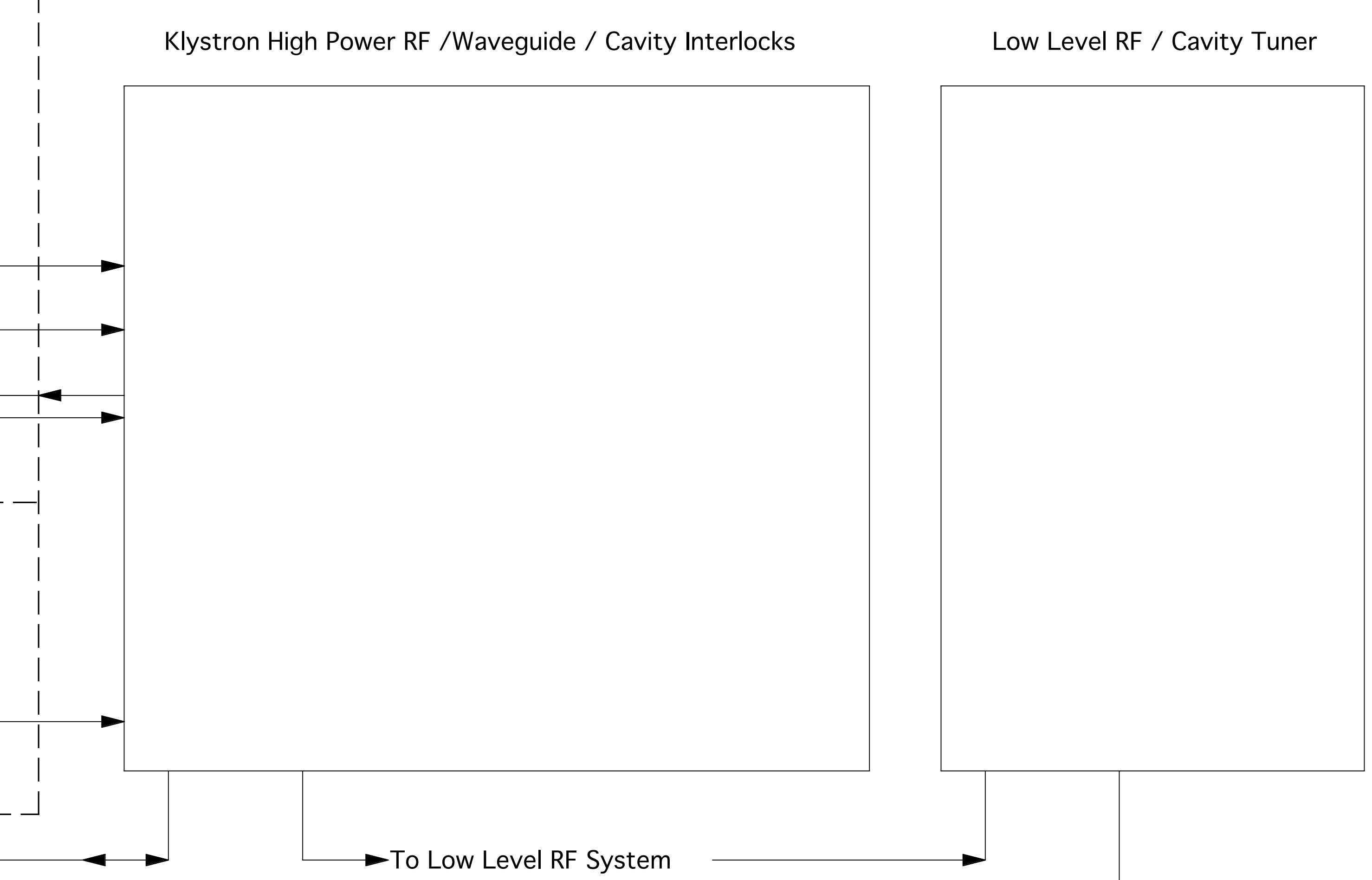
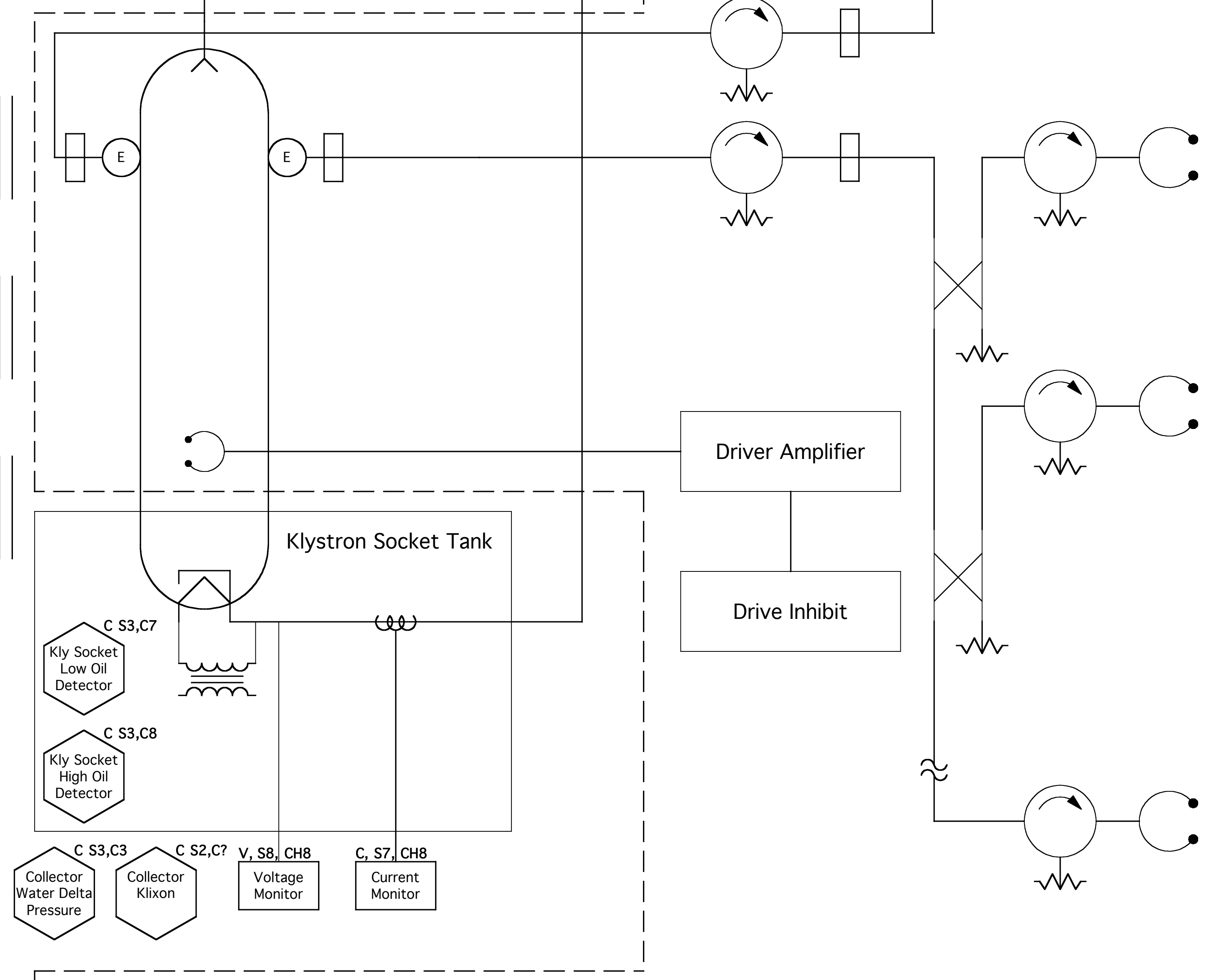
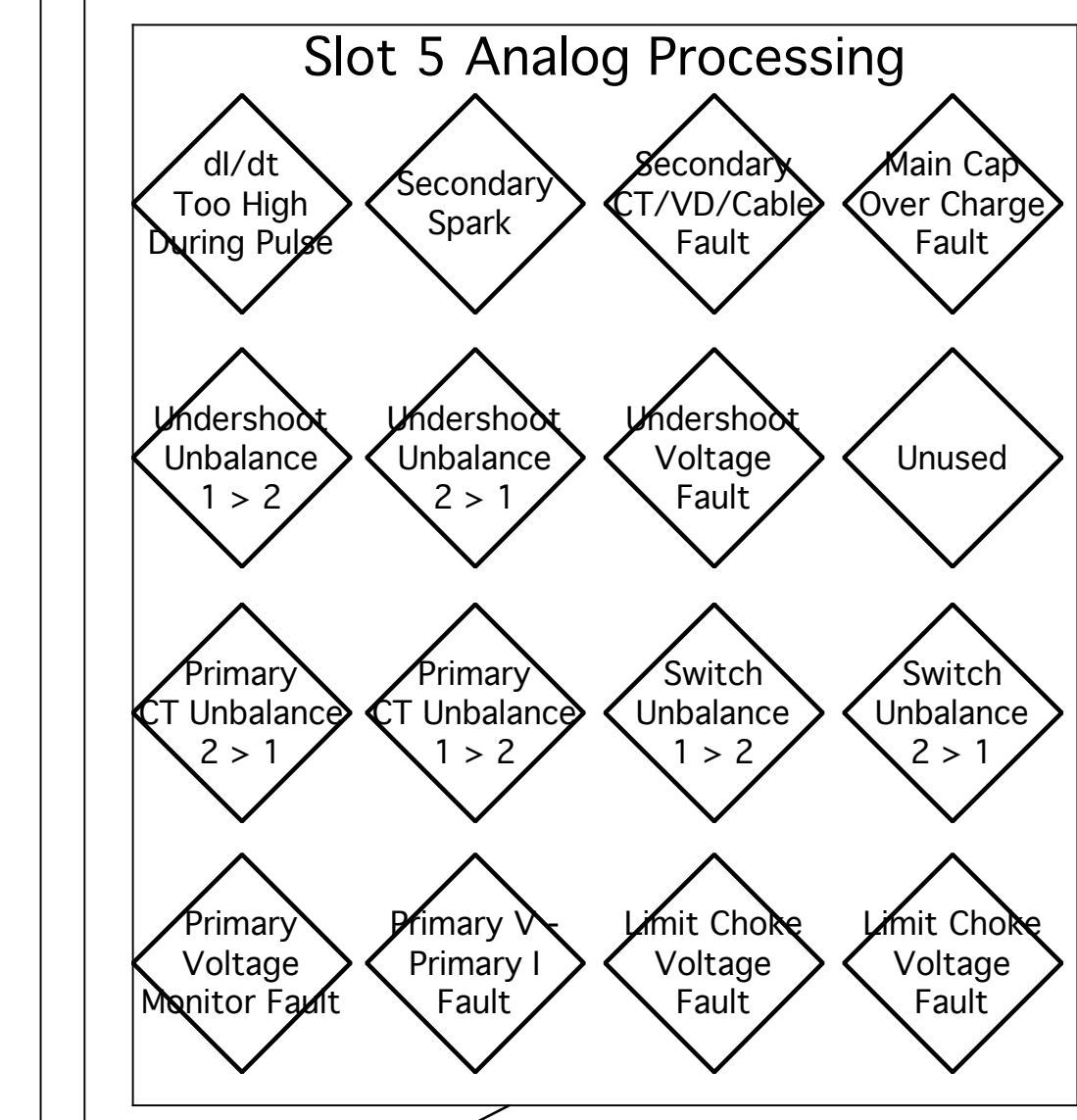
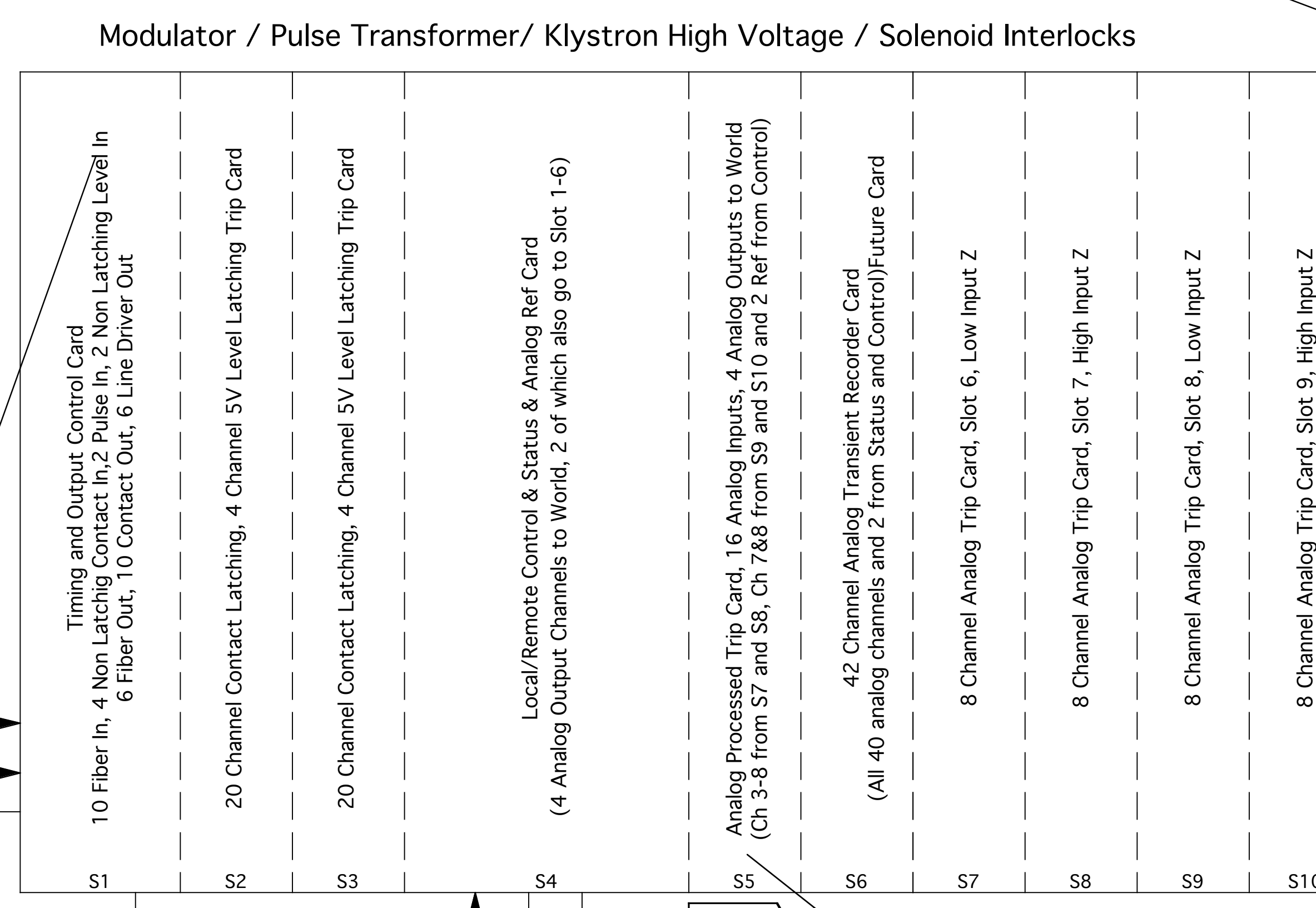
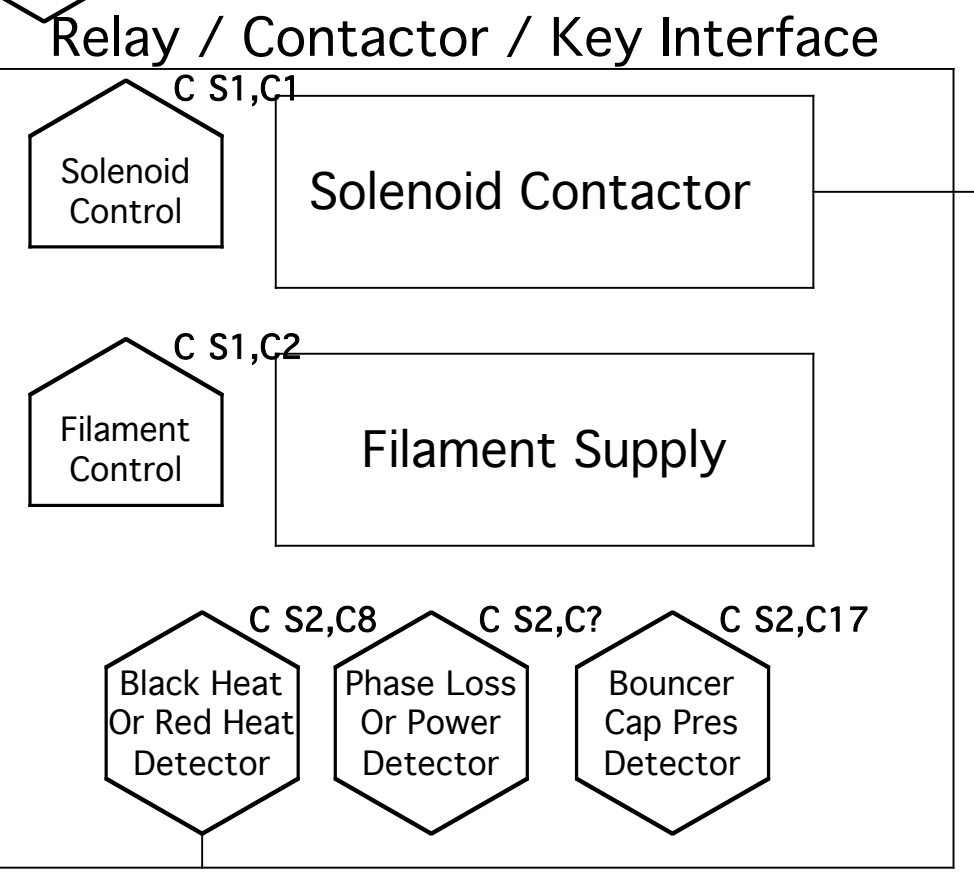
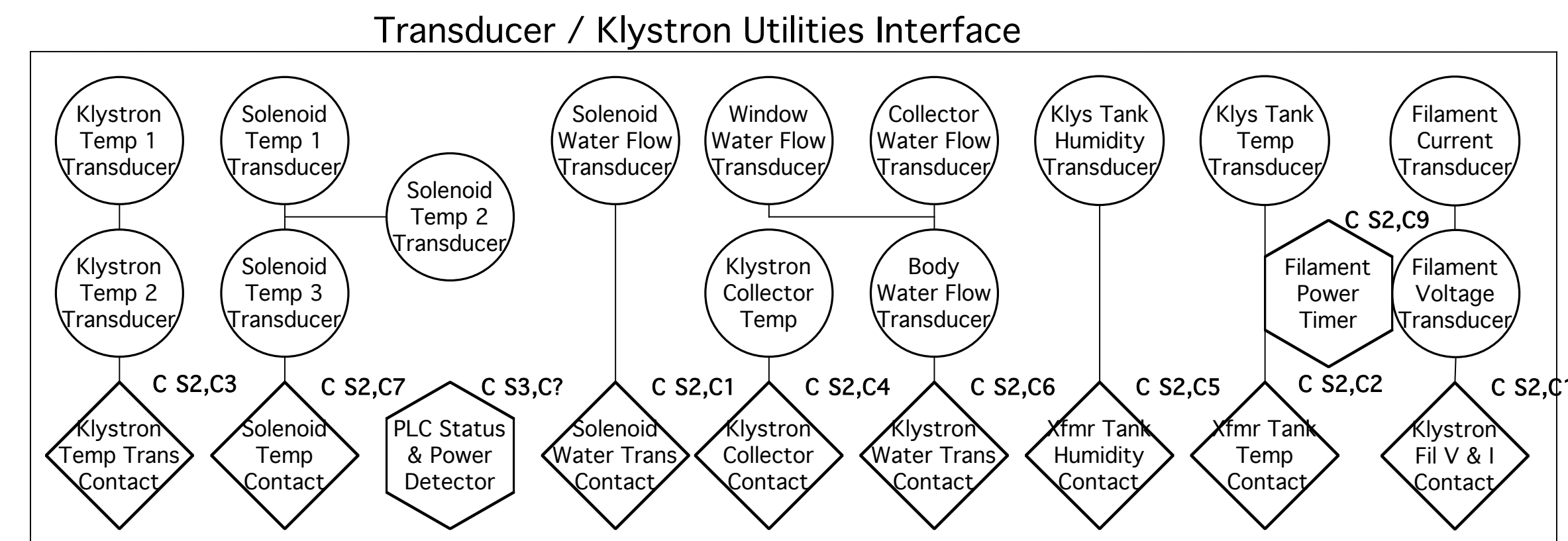
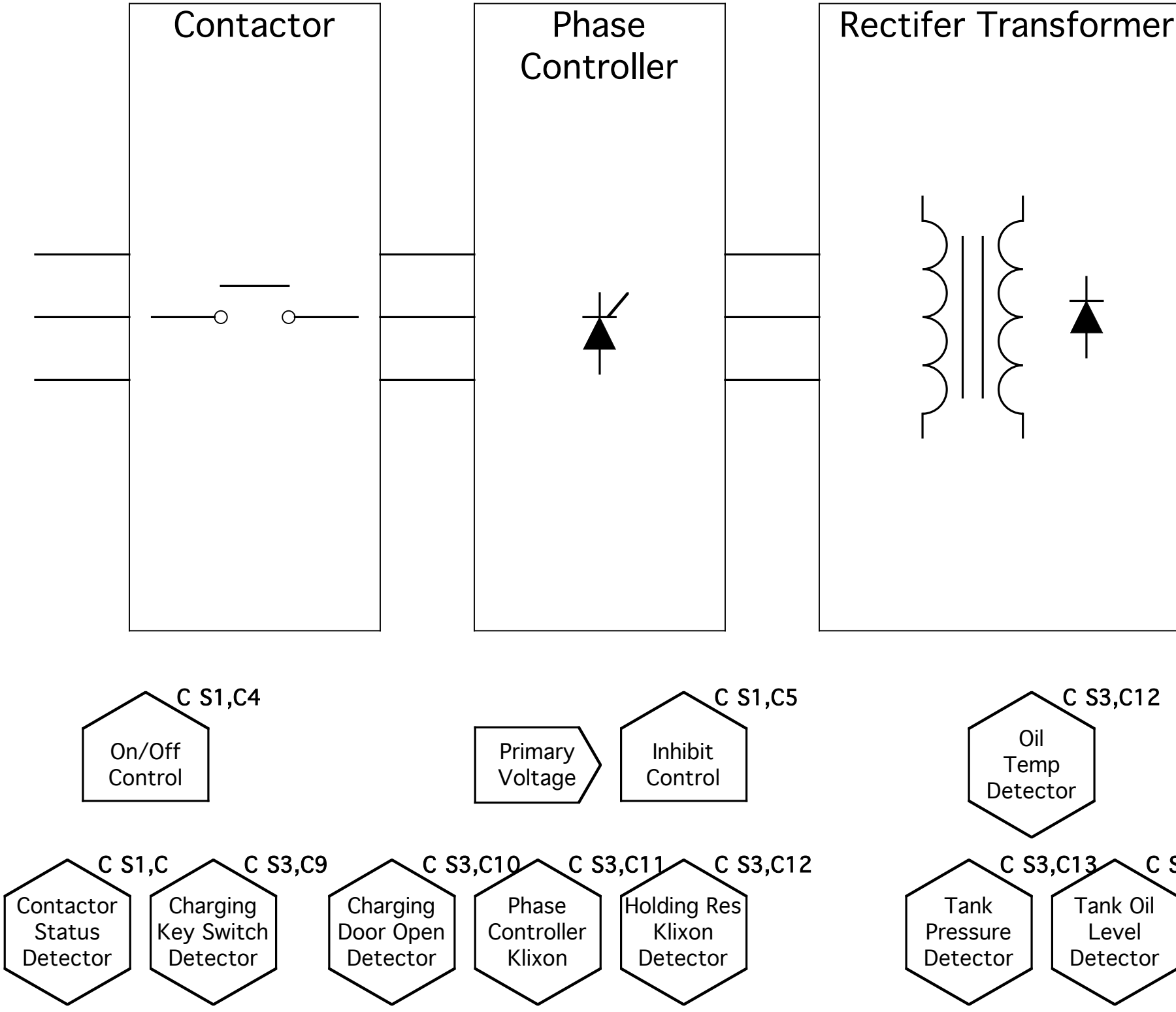
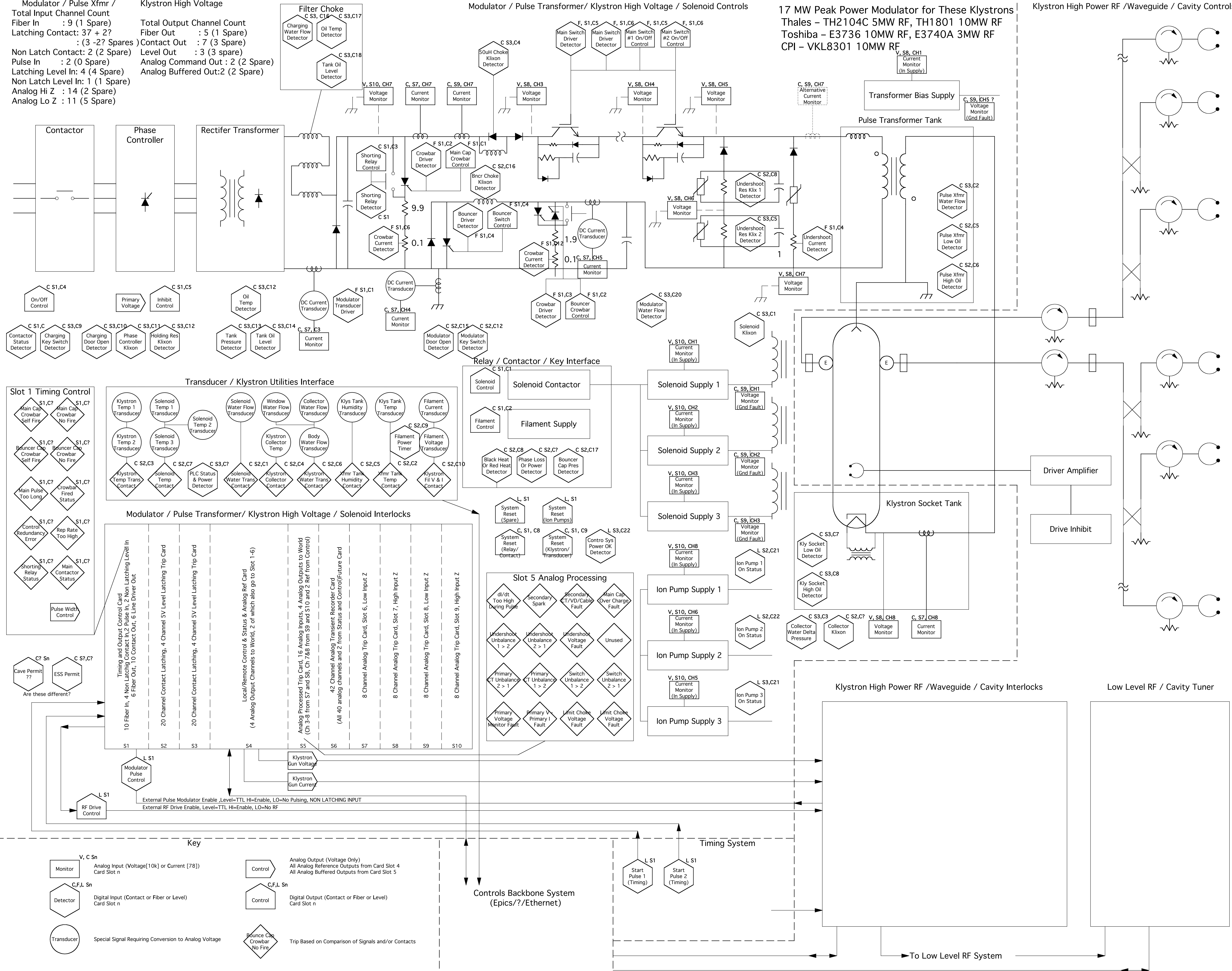

Controls Backbone System (Epics/??/Ethernet)