



LLRF writing for Part-2

J. Carwardine, S. Michizono



- LLRF description is a subsection under HLRF
 - **Writing has not been started yet, but we now know largely what we want to write – will be done in a month**
- Default assumption is that LLRF description in RDR is still applicable
 - **Mostly true, but with some adjustments and new figures**
- Main changes are driven by changes to HLRF / ML
 - **RDR-like : LLRF concept is essentially identical to RDR**
 - **KCS: nothing done on LLRF design during TDR**



RDR / RDR-like

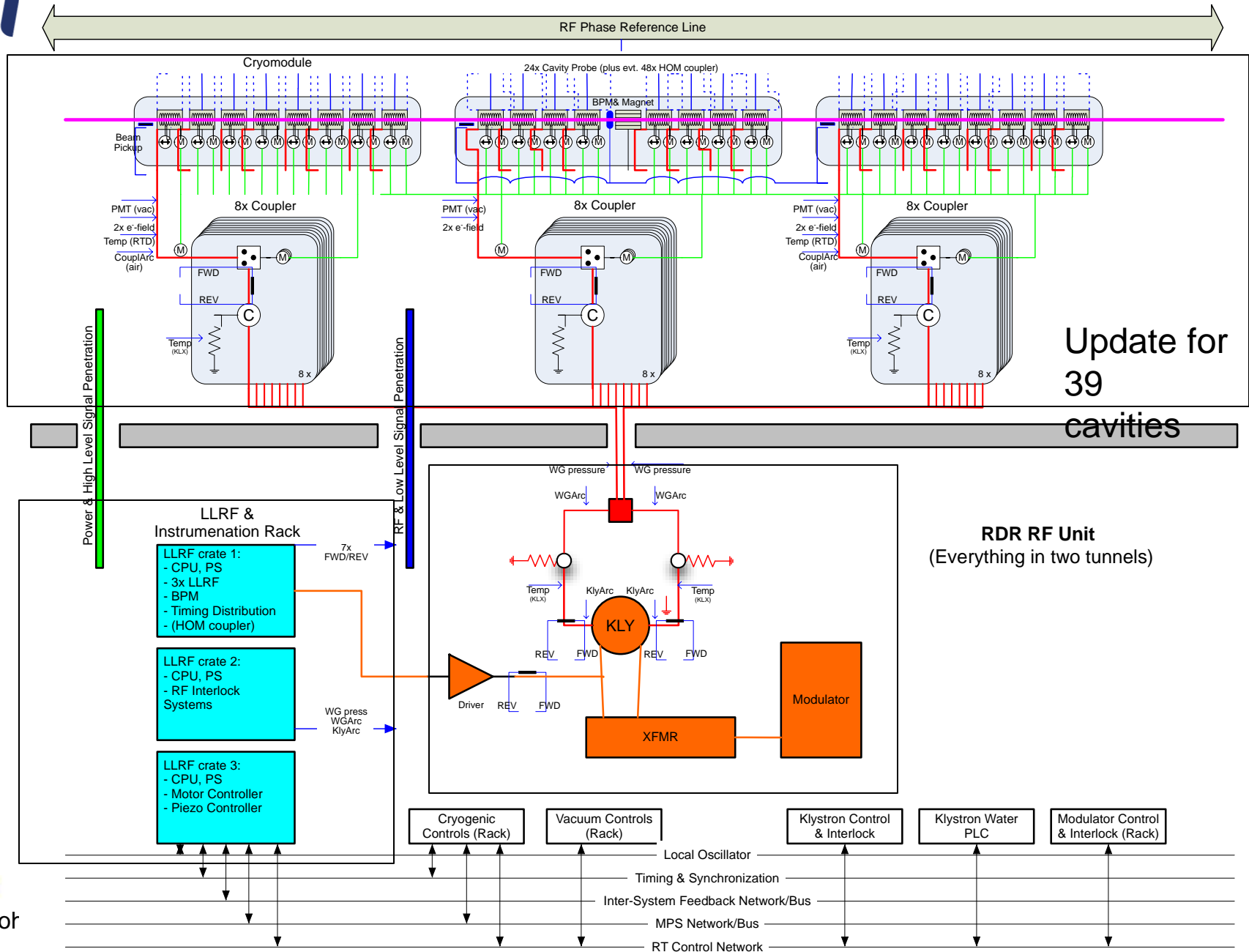



KCS – global view

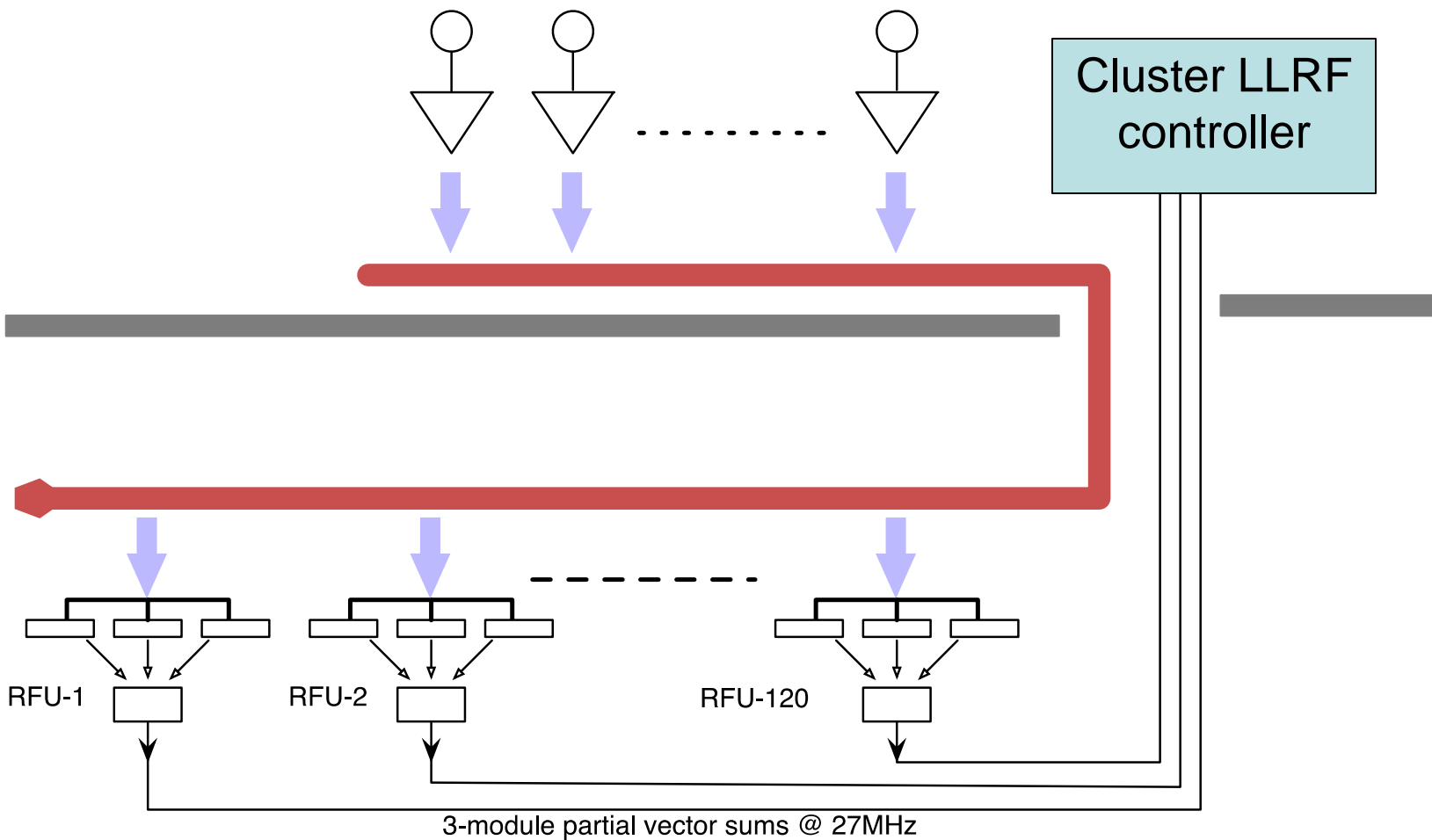



KCS LLRF concept – local at RF unit

(local equipment, functionality is identical to RDR-like)

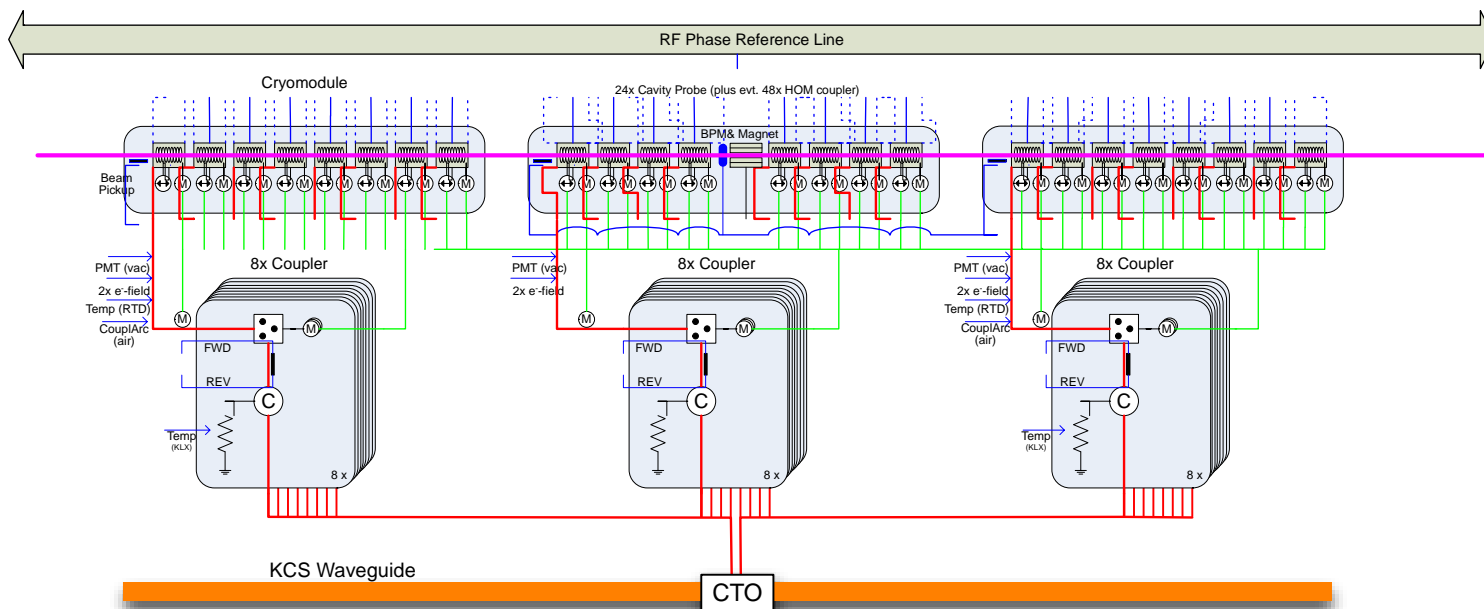

Difference to RDR-like is the rf power delivery

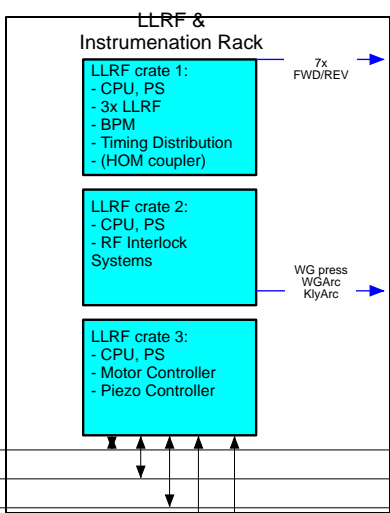

Local processing equipment

