

AHCAL integration in ILD

status report

Karsten Gadow

ILD Magnet & calorimeters integration

LAL, 01.-02.02.2012

AHCAL barrel absorber study

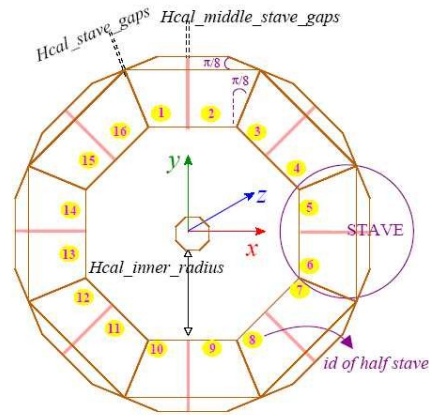
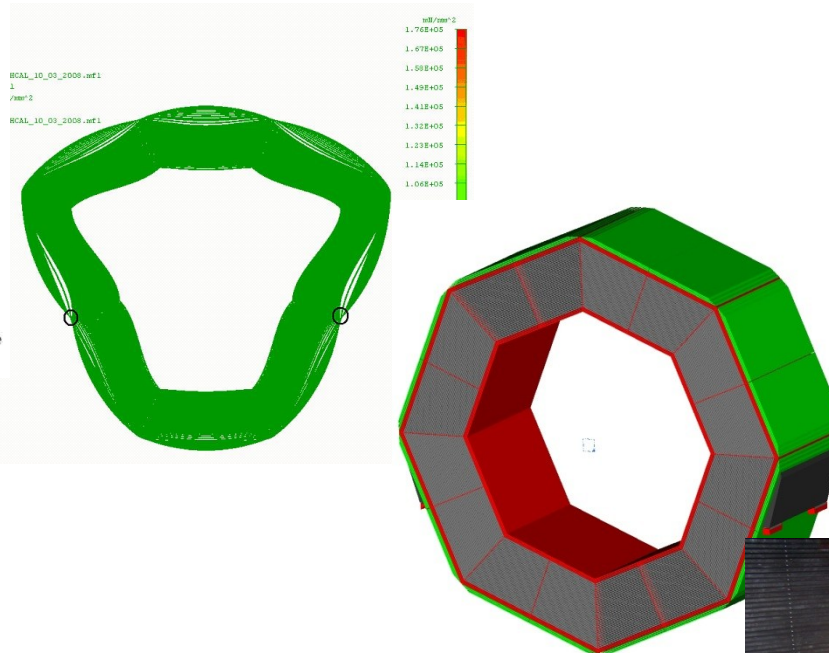

Figure 3: $x - y$ view of the HCAL barrel. The angle of symmetry is $\pi/8$.



1m³ physics prototype with sensitive layers running!



AHCAL barrel integration in ILD step 1

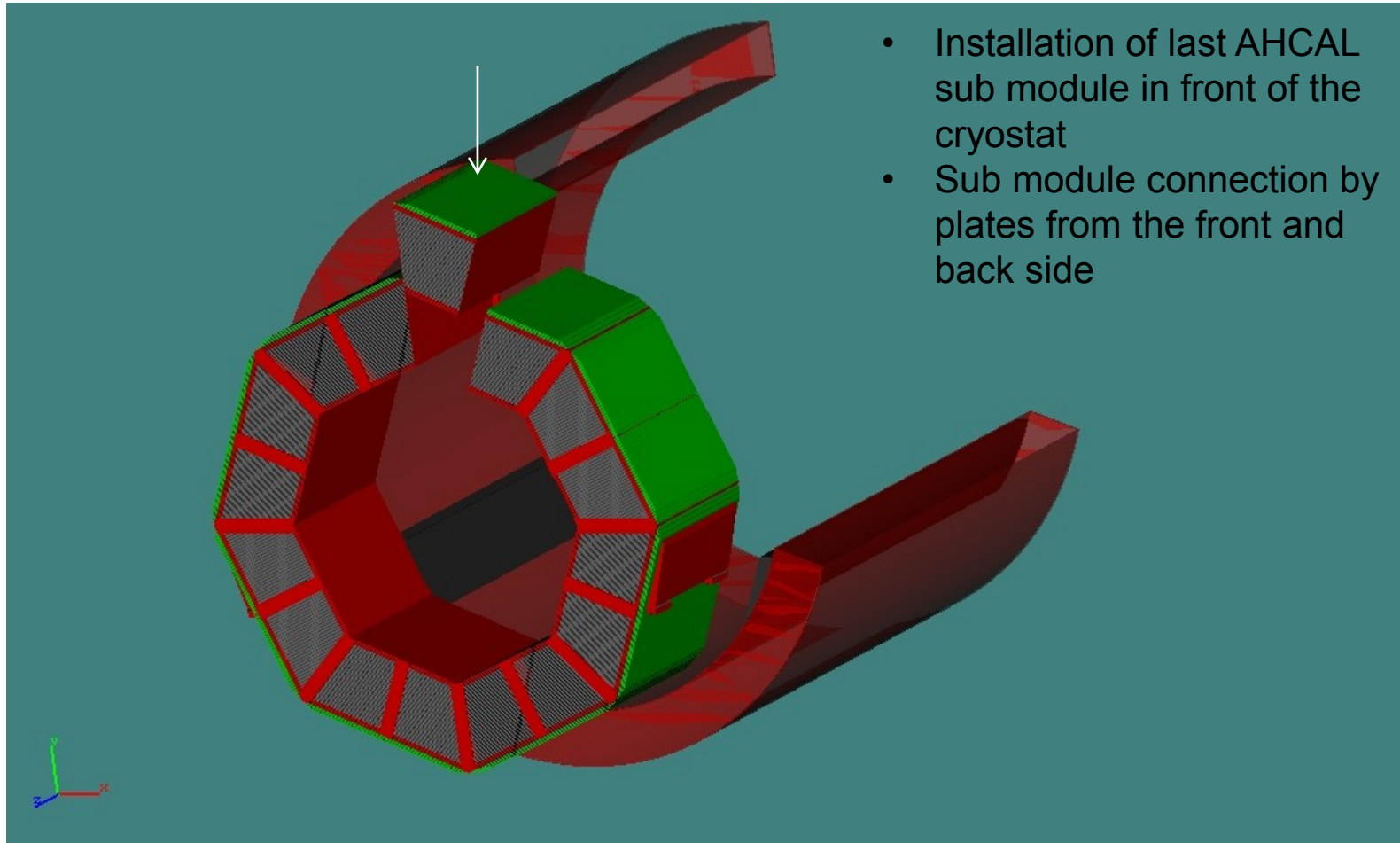

AHCAL barrel integration in ILD step 2

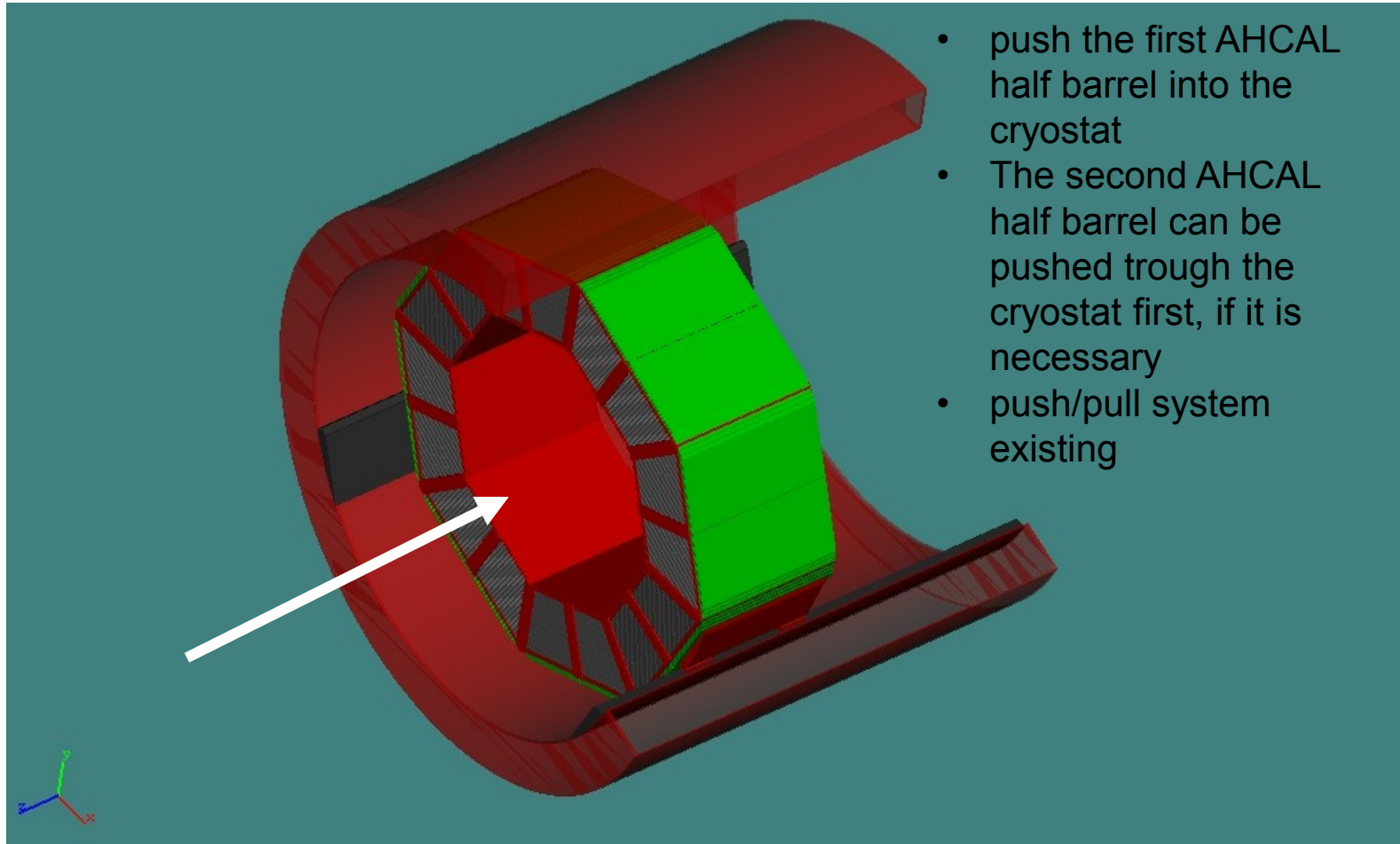

- push the first AHCAL half barrel into the cryostat
- The second AHCAL half barrel can be pushed trough the cryostat first, if it is necessary
- push/pull system existing

AHCAL barrel integration in ILD step 3

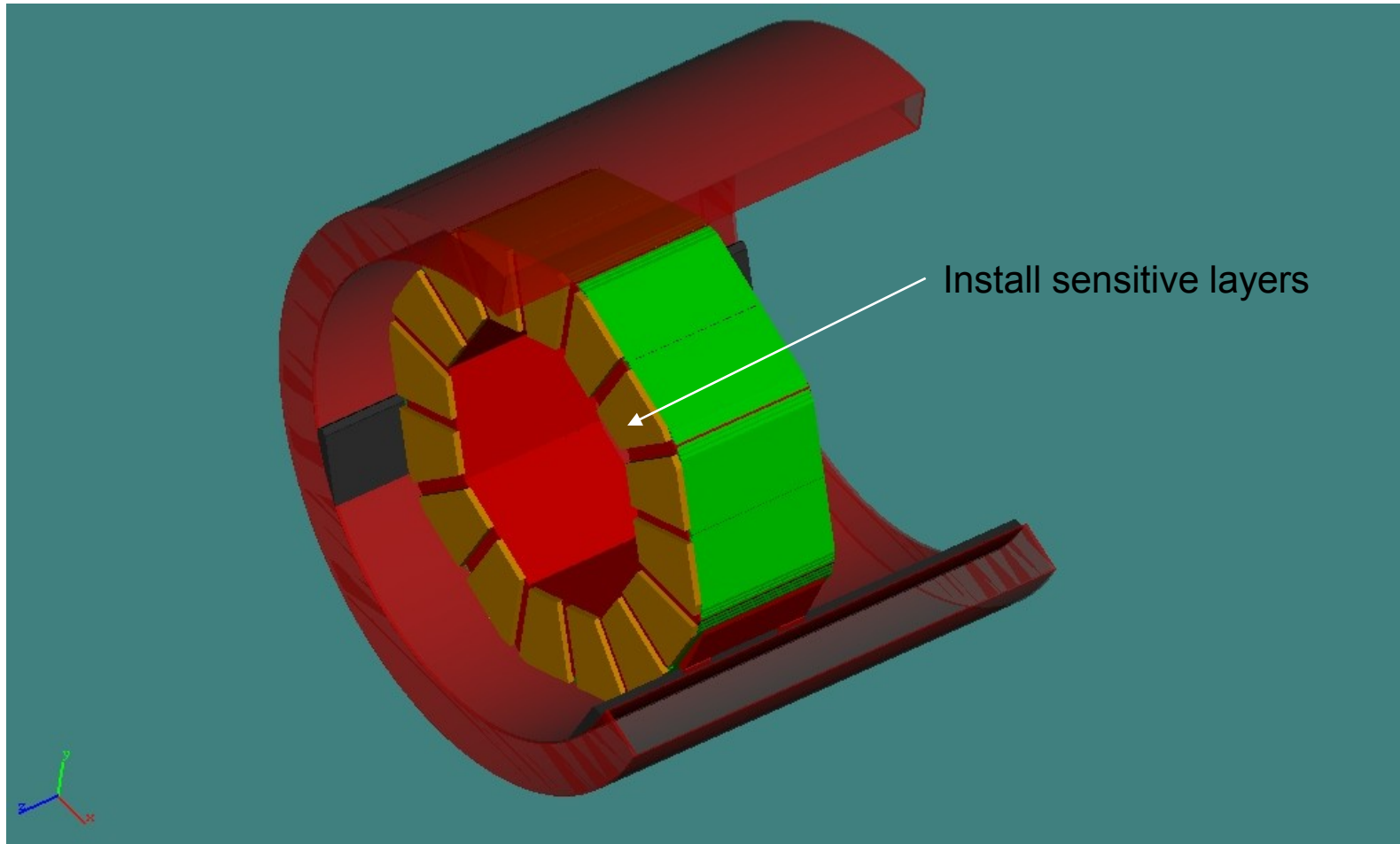

AHCAL barrel integration in ILD step 4

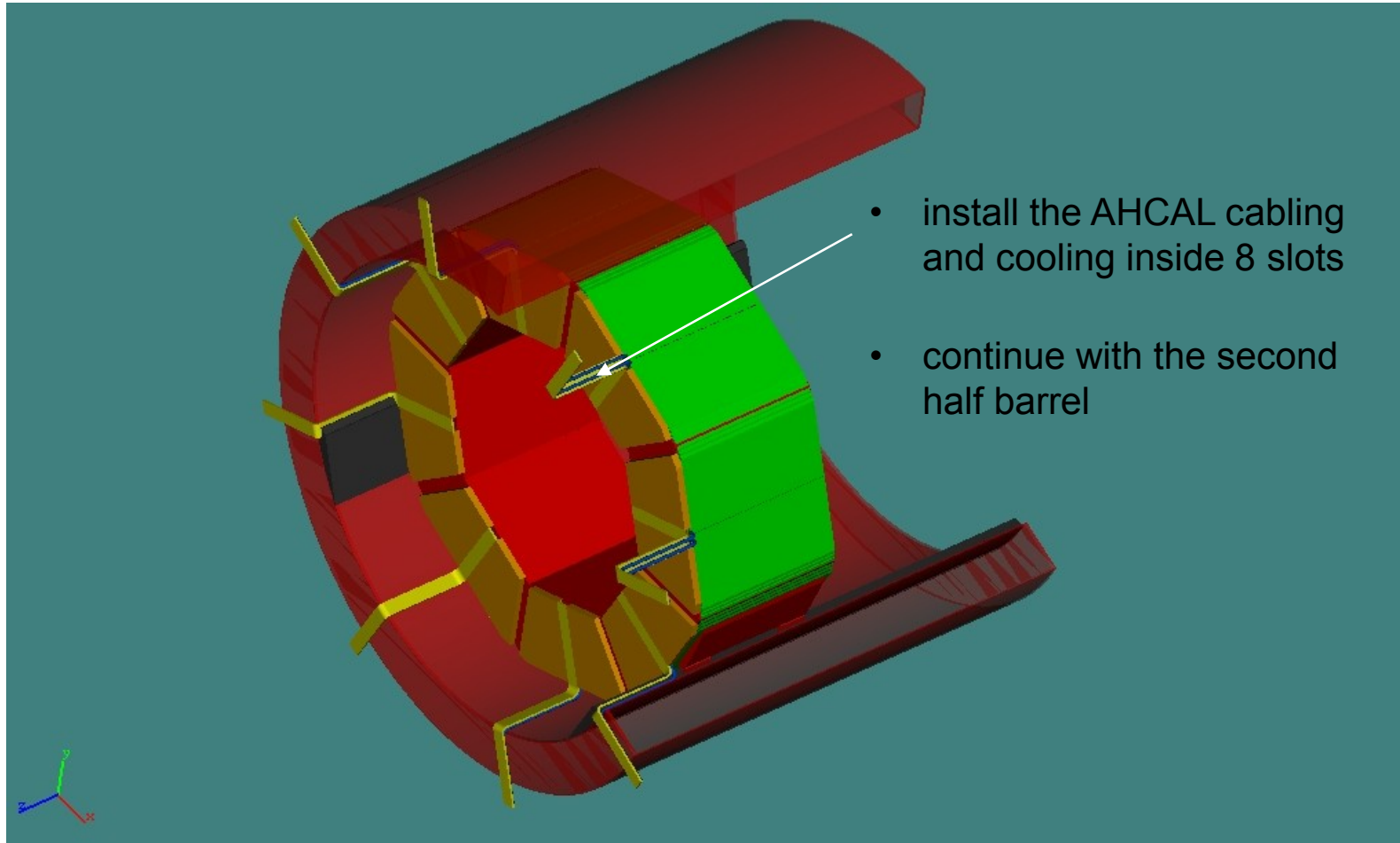

AHCAL barrel integration tools

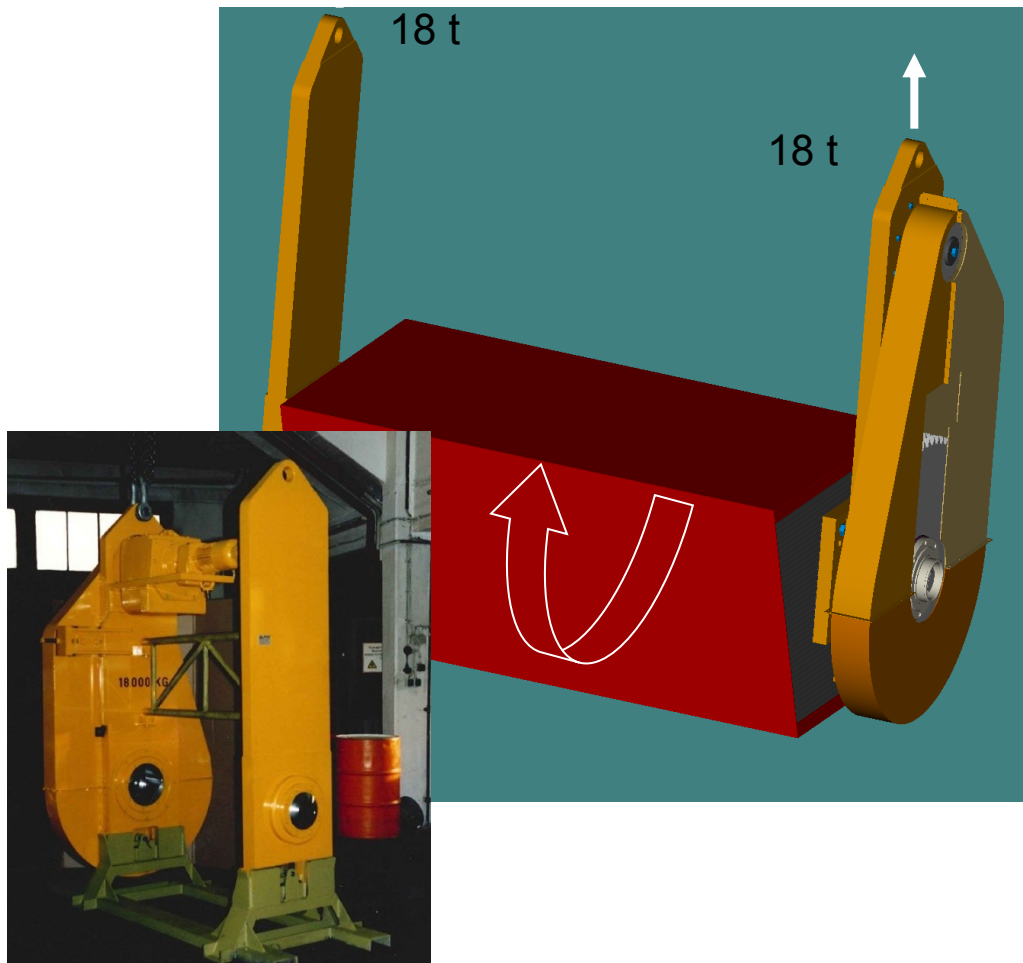

- > lifting and turning tool for AHCAL barrel absorber sub-modules available
 - 2 x 18 t capacity
 - operation with 2 hooks (z angle adjustment)
 - precise motor controlled turning
 - design for adaptation for sub-modules with and without sensitive layers started
- > mounting, support and insertion frame
 - one frame for everything
 - design depends on installation procedure
- > push and pull tool available
 - must be modified to the rail distance and rail shape/size

ECAL barrel integration in ILD

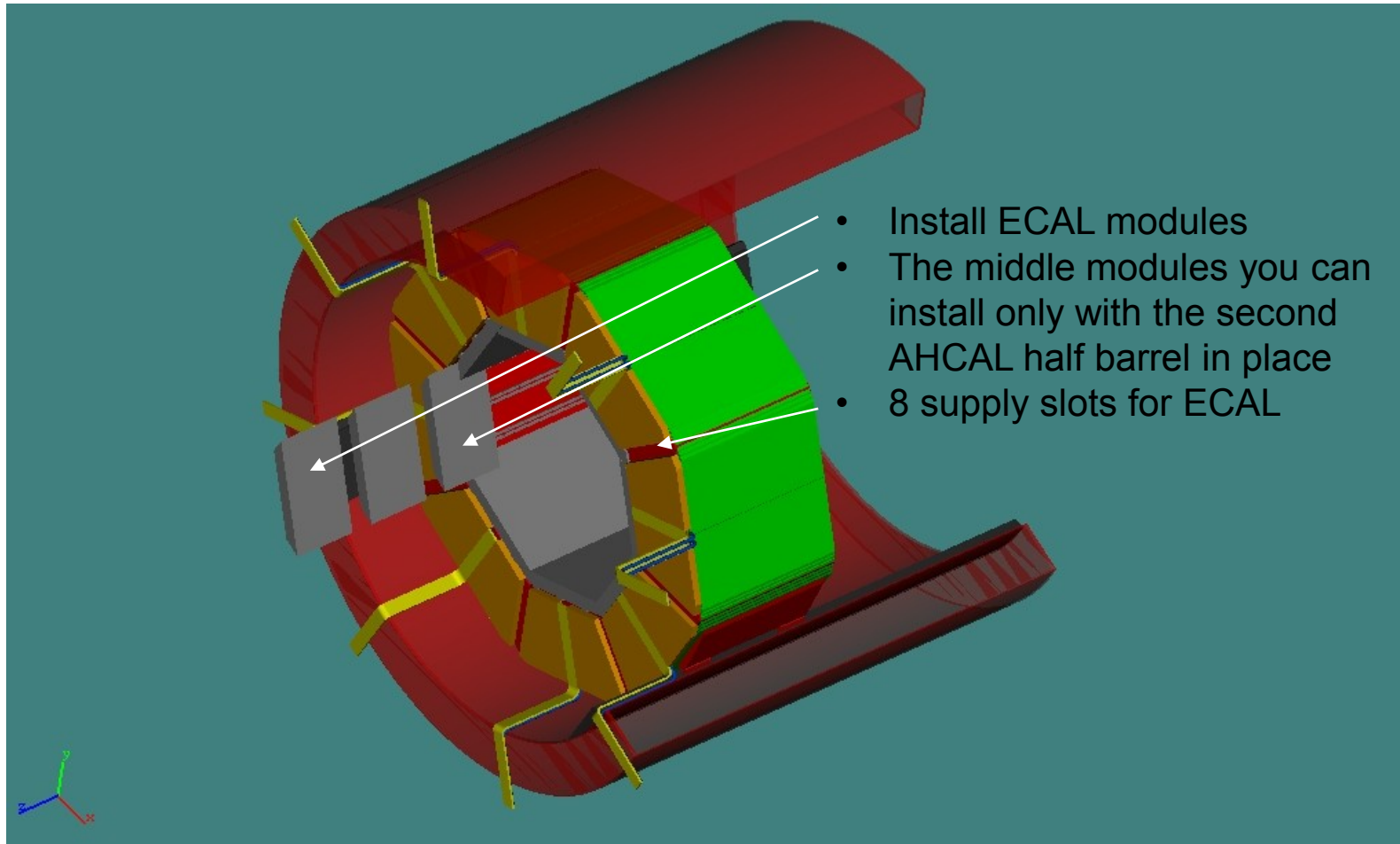

AHCAL barrel in ILD summary

not confirmed :

- geometry
 - rotation still under discussion -> impact to ECAL end cap

known :

- mechanical solution
- production process
- installation scenario
- supply routes
- interfaces

90% mechanical design for AHCAL barrel done!

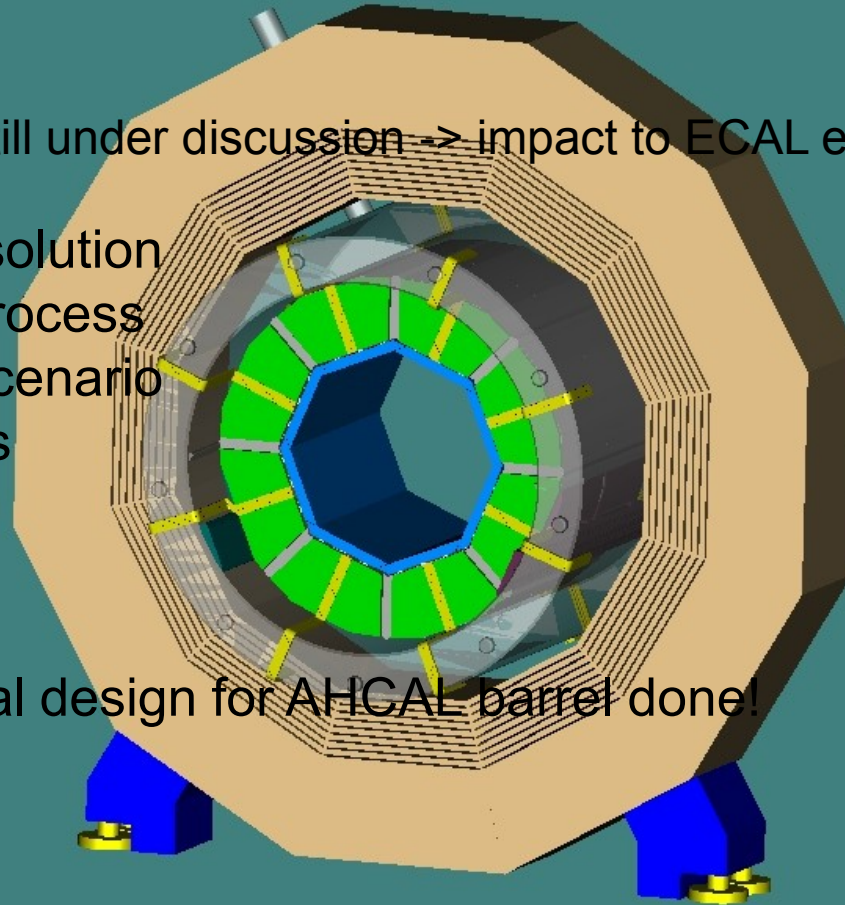

AHCAL end cap support

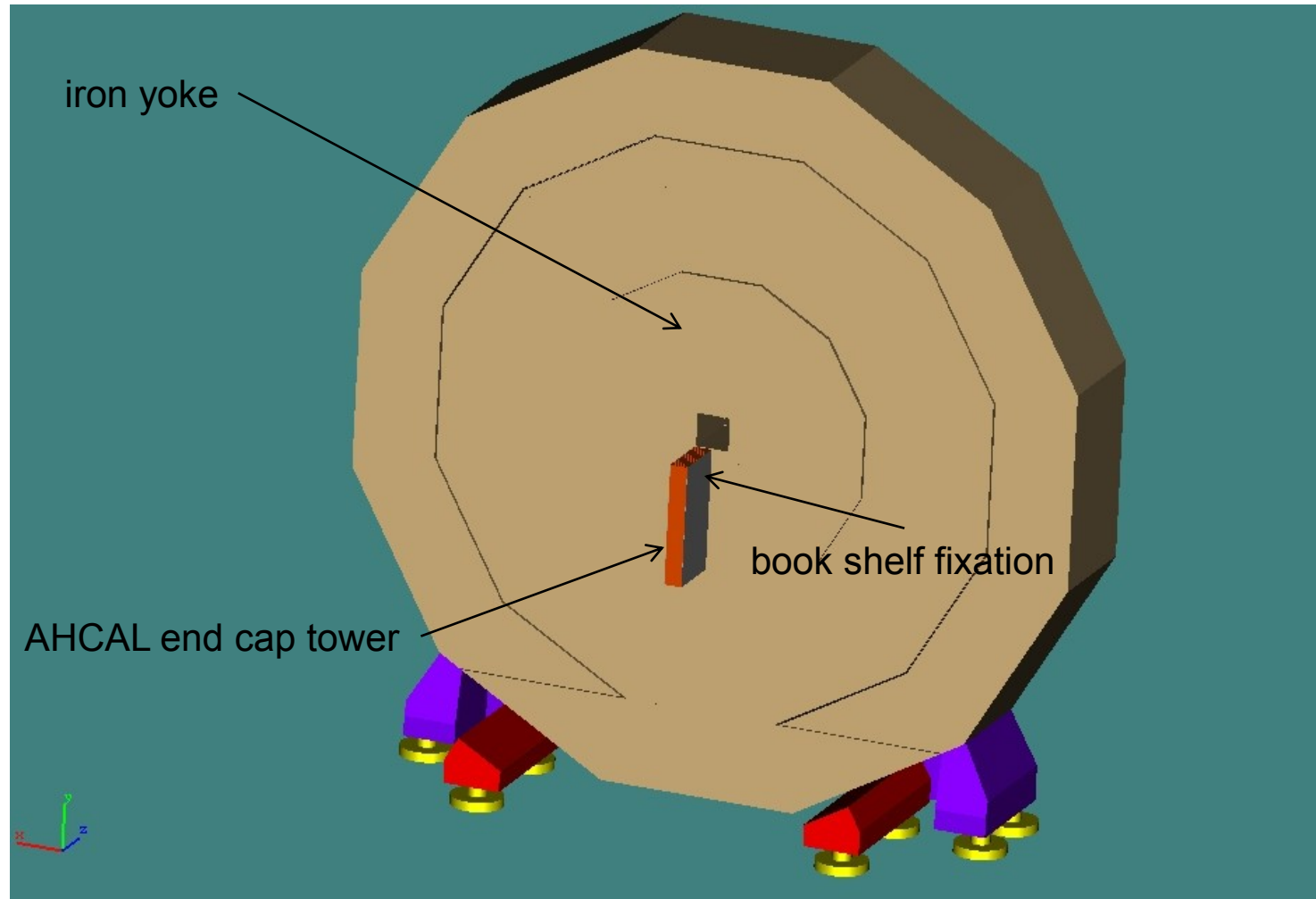

AHCAL end cap installation

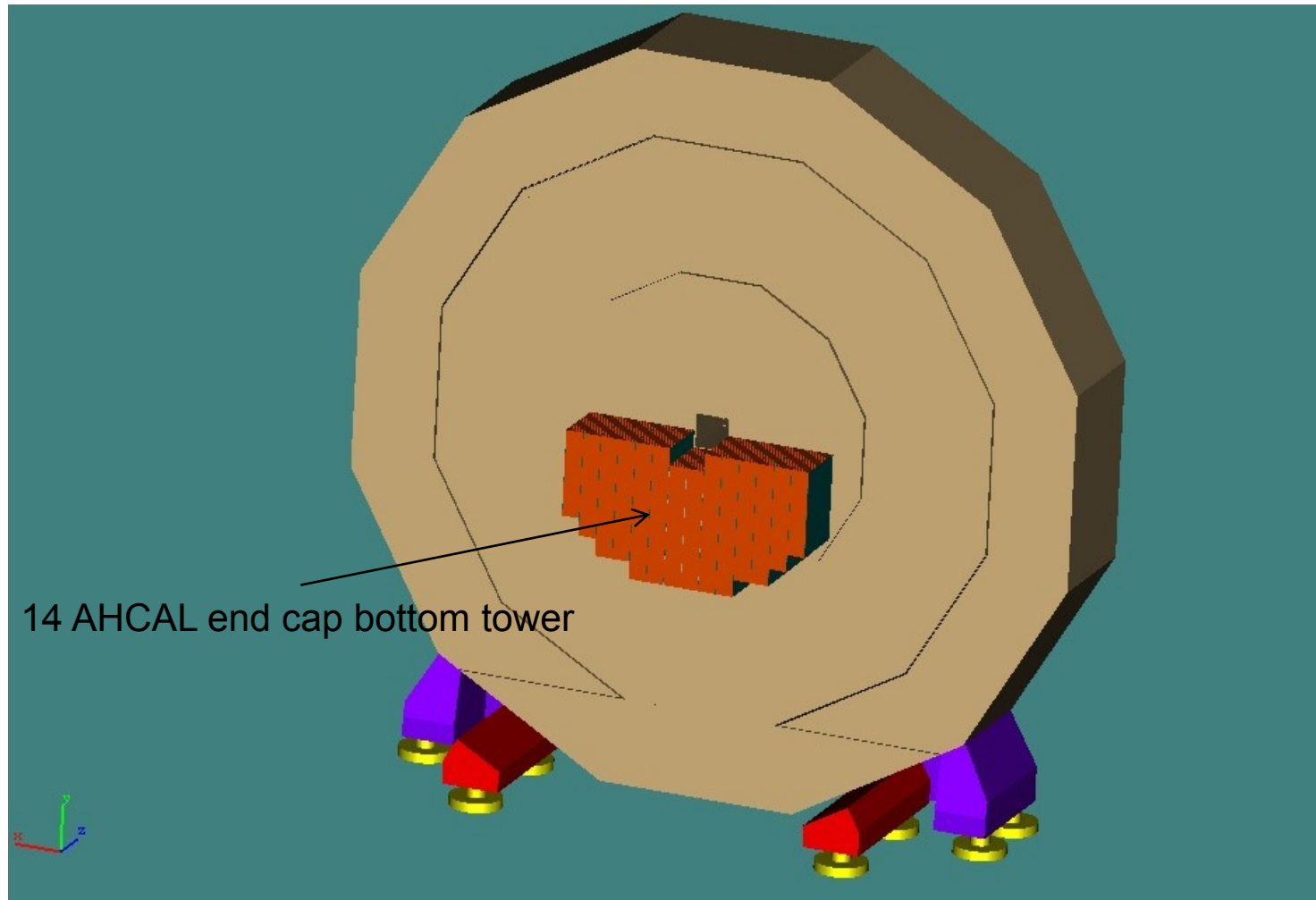

AHCAL end cap supply

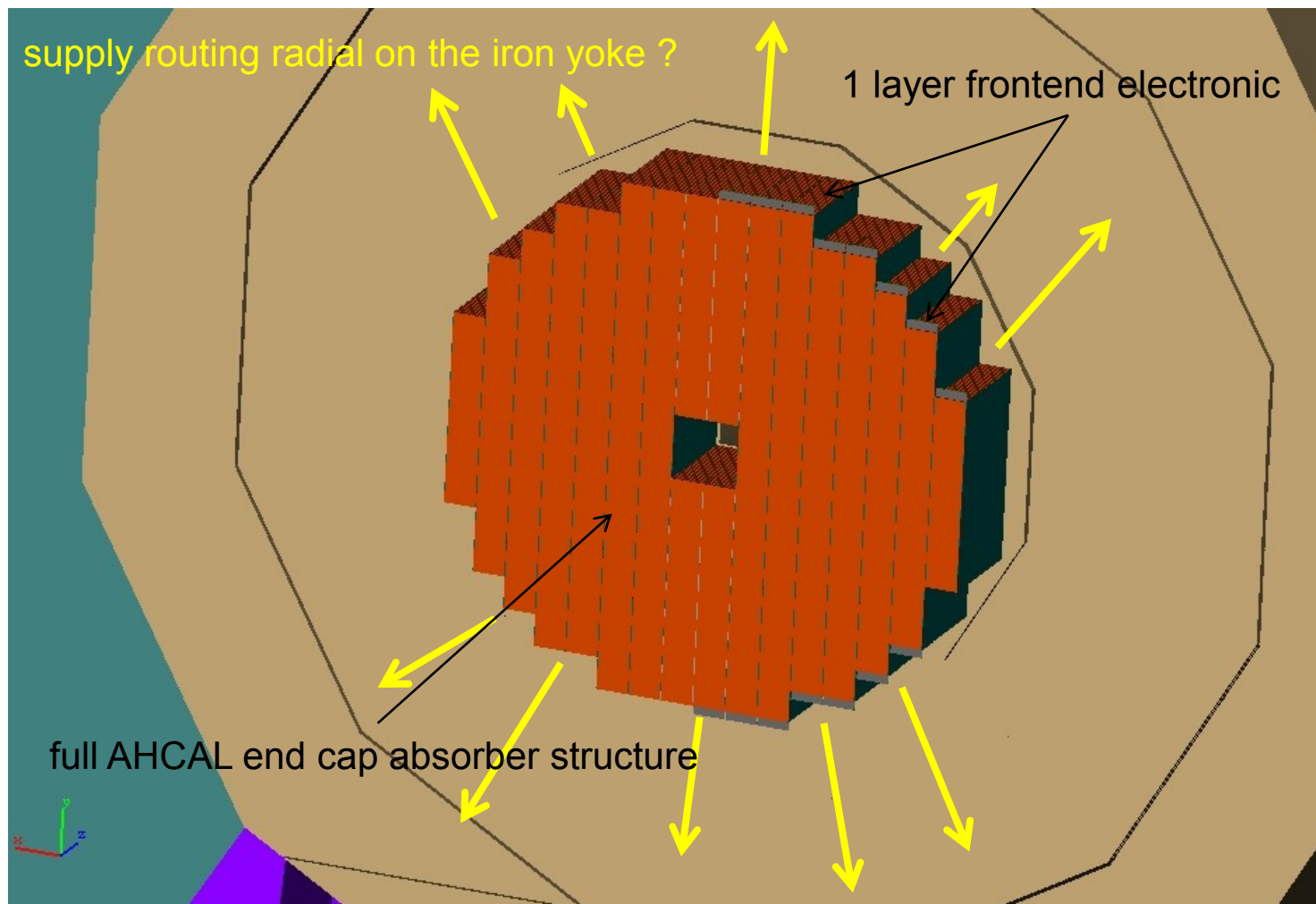

AHCAL end cap with ECAL end cap

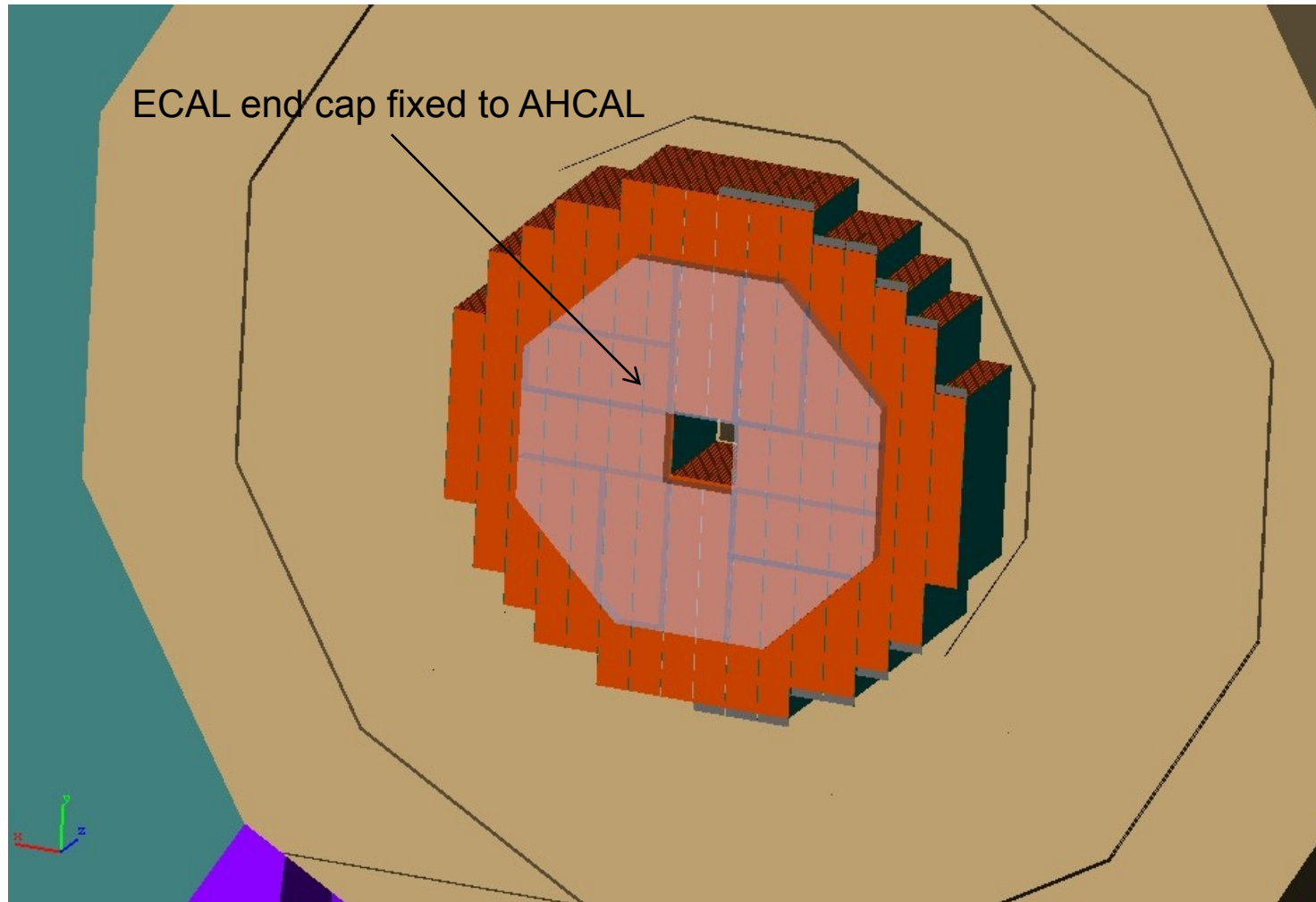

AHCAL end cap with ECAL end cap and ETD rotated

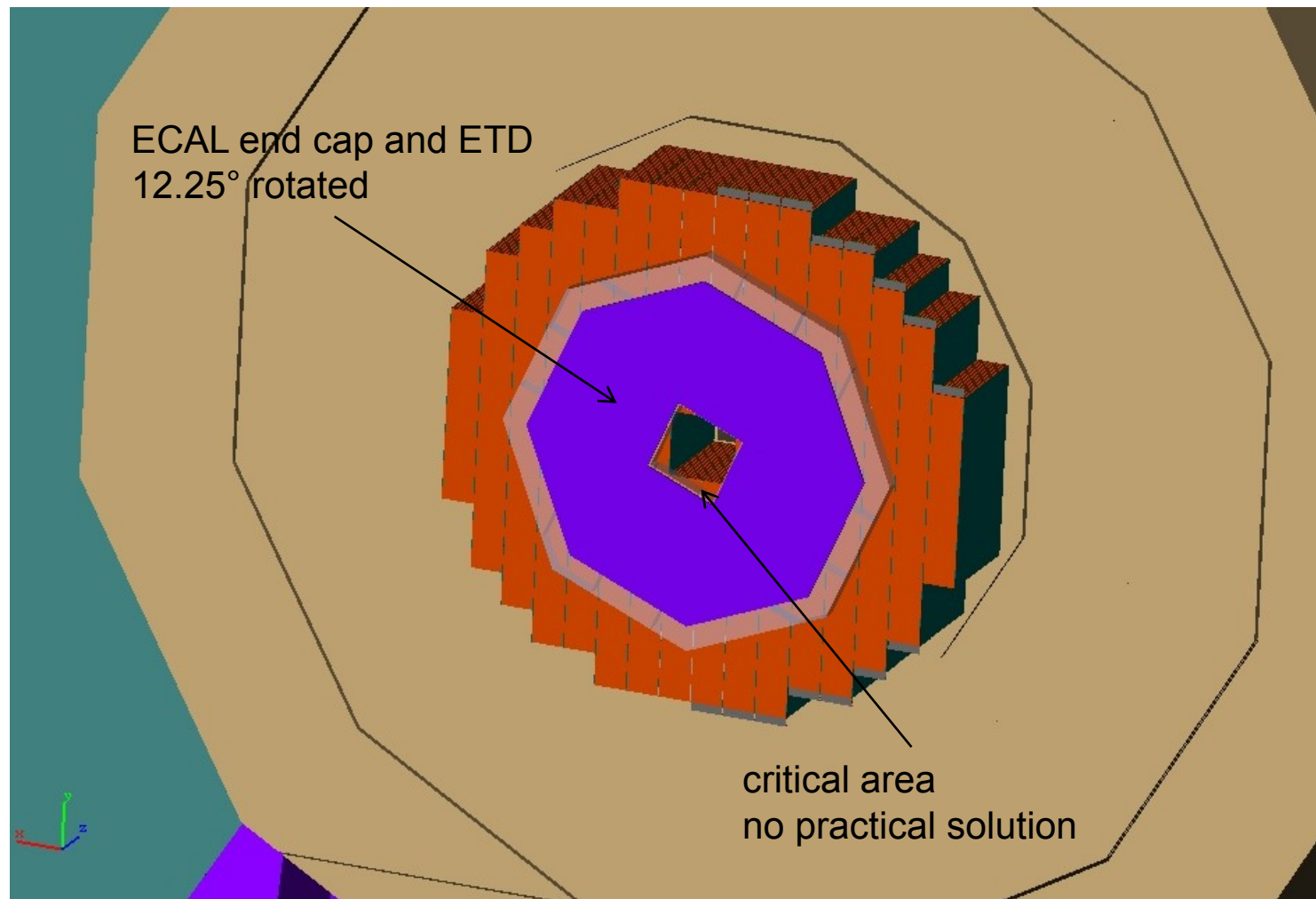

AHCAL end cap in ILD summary

not confirmed
- geometry
known

- mechanical solution
 - production process
 - installation scenario
- unknown
- supply routes
 - interfaces

AHCAL end cap ring

useful ?

60% mechanical design for AHCAL end cap done!

