

The Laser Holder Support Frame

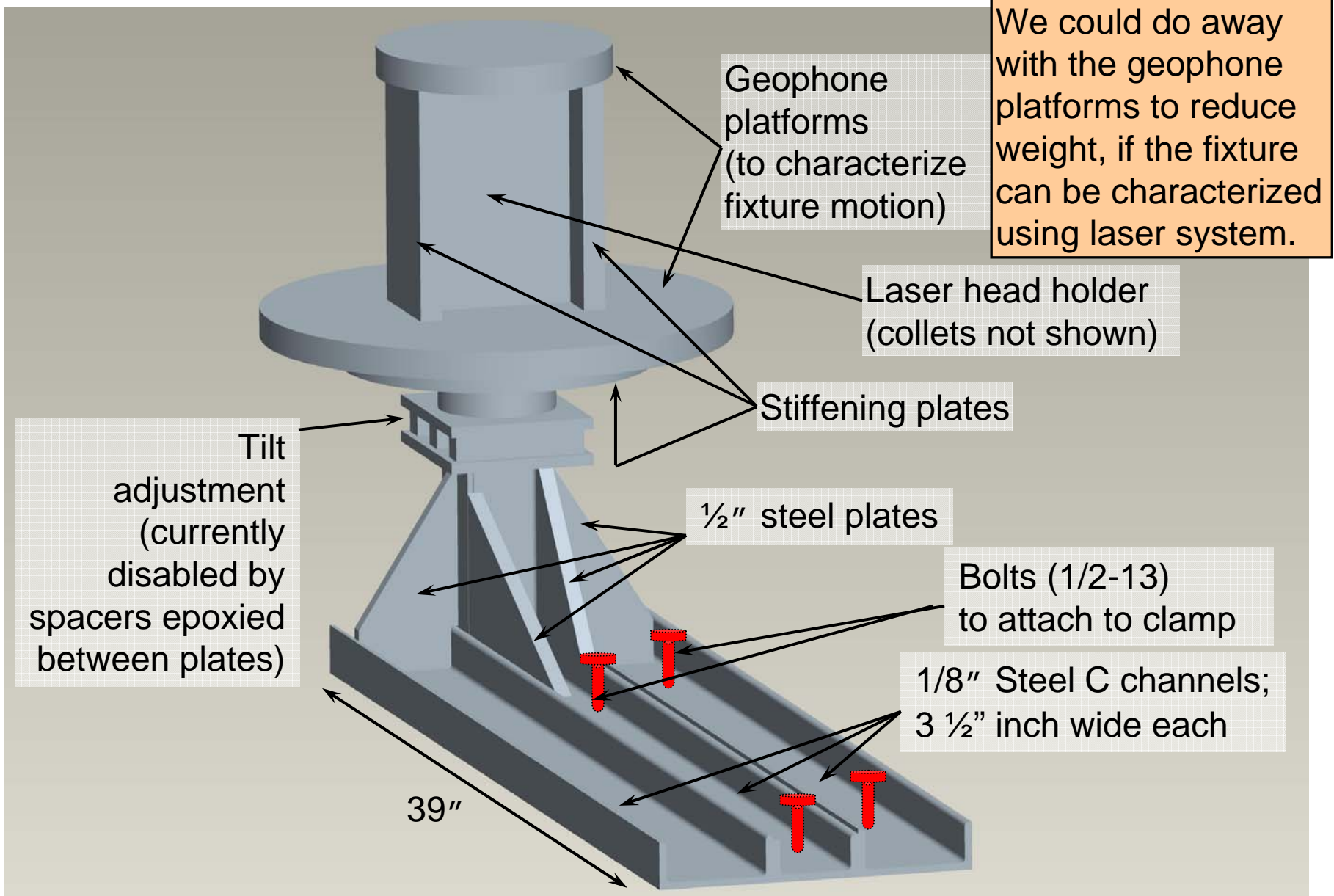

Laser Holder: Critical Dimensions

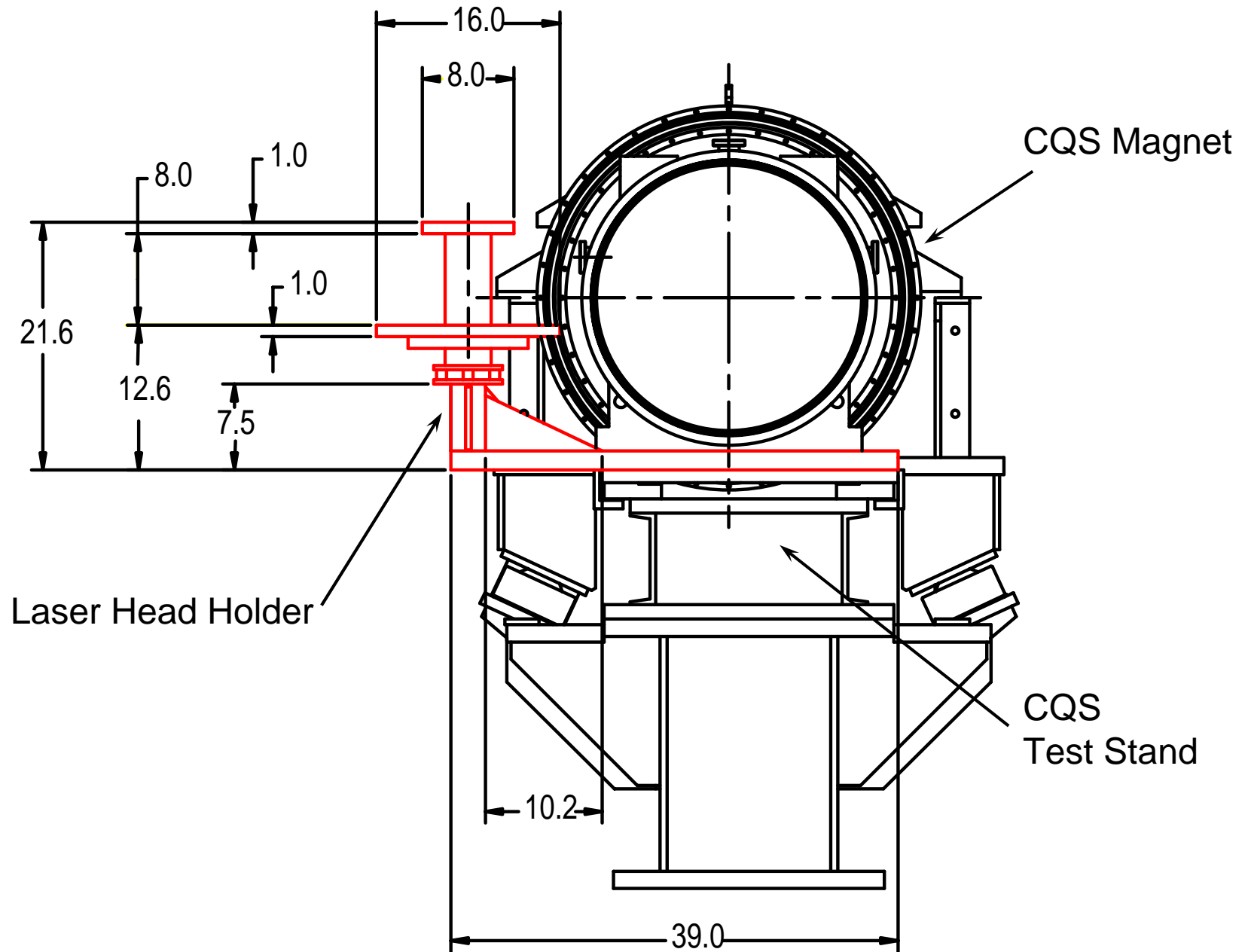

Laser Holder Attachment to the CQS stand

Laser holder base is bolted to a clamp, which in turn is attached to the test stand.

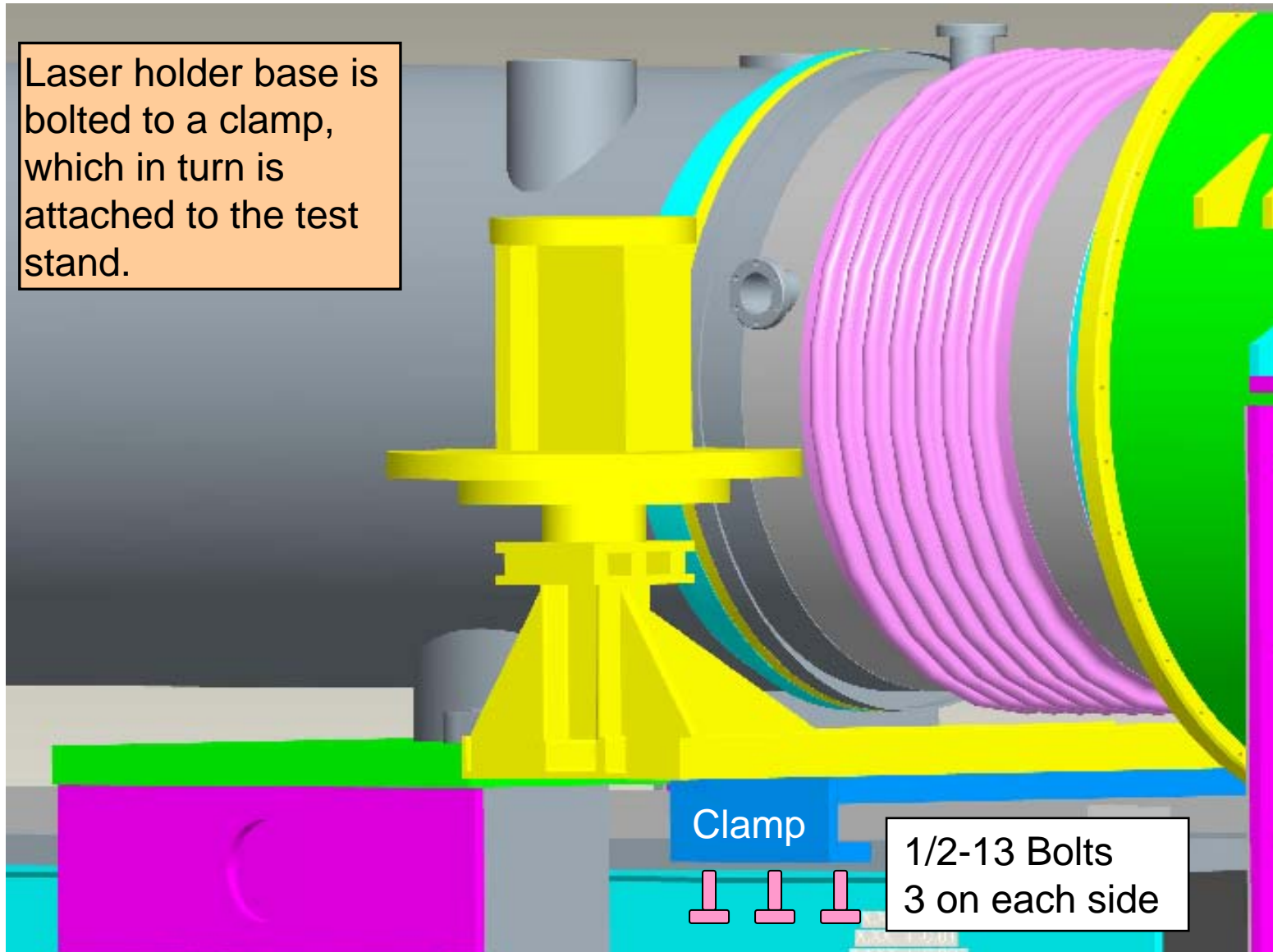

Clamp



1/2-13 Bolts
3 on each side

Laser Head Holder on the CQS stand

