

# Cavity Field Control

- Feedback Performance and Stability Analysis

LLRF Lecture Part 3.2

S. Simrock, Z. Geng

ITER / SLAC

## Motivation

- Understand how the perturbations and noises influence the feedback control performance – field stability
- Identify the most critical parts of the LLRF system concern to field stability

- Overview of the RF feedback control system
- Sensitivity of the field error to system parameter variations
- Sensitivity of the field error to noises
- Feedback stability

# RF Feedback Control System Overview

Goal:  
Maintain stable gradient and phase

Solution:  
Feedback for gradient amplitude and phase:

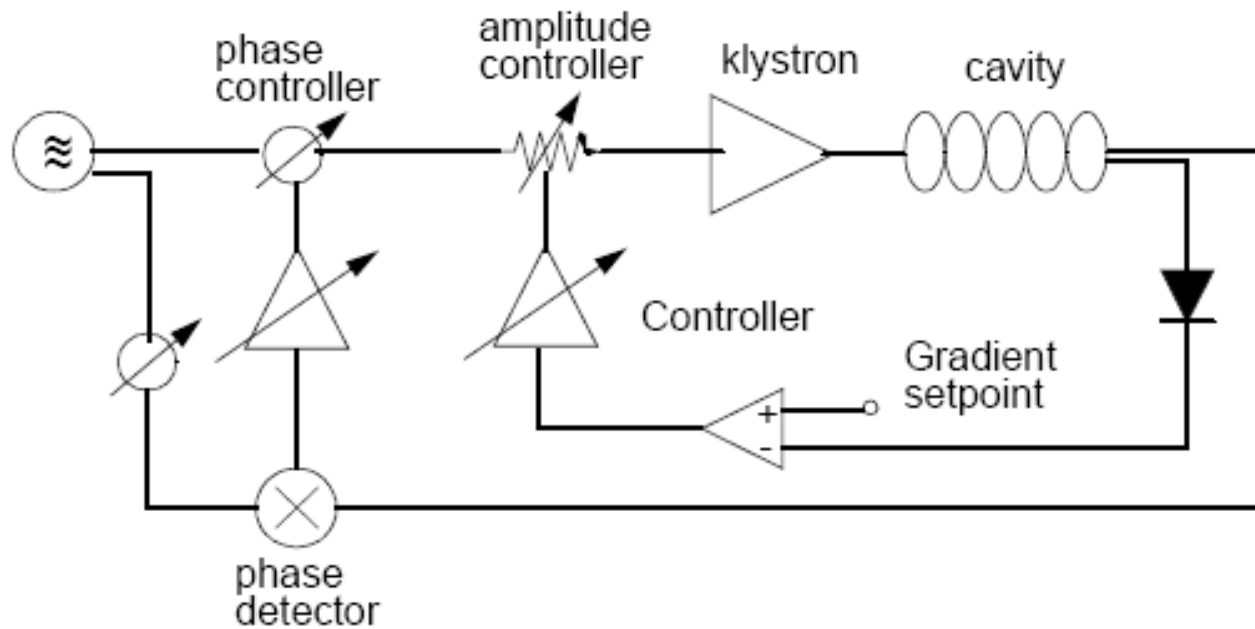

Model:

Mathematical description of input-output relation of components combined with block diagram:

Amplitude Loop (general form):

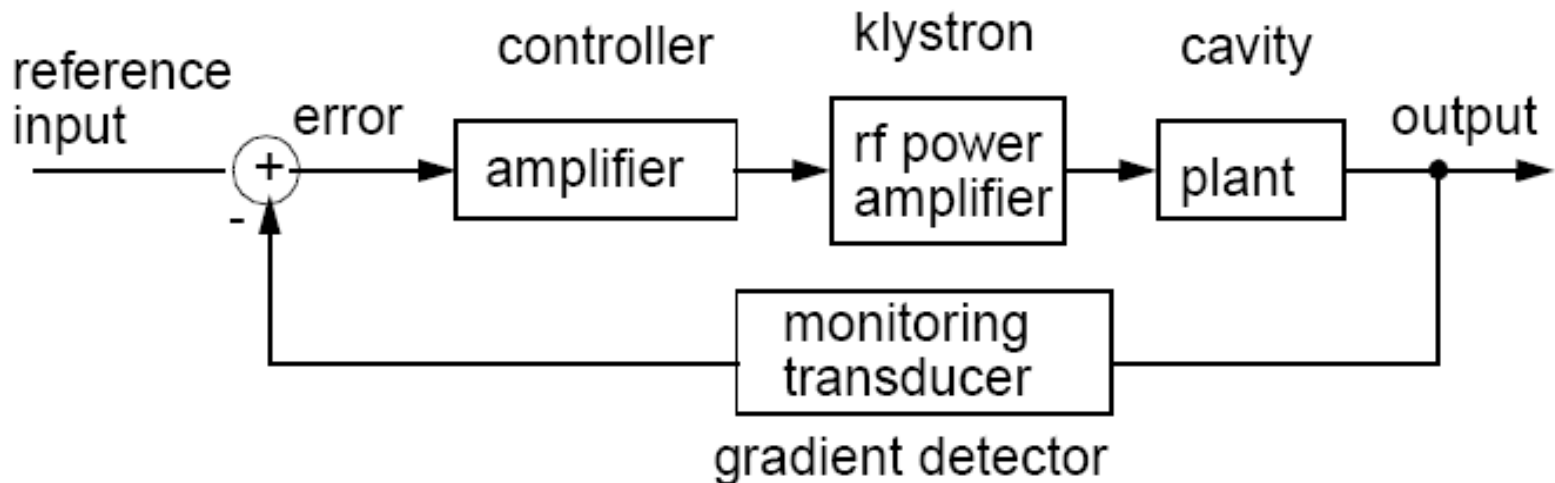

RF Control model using “transfer functions”

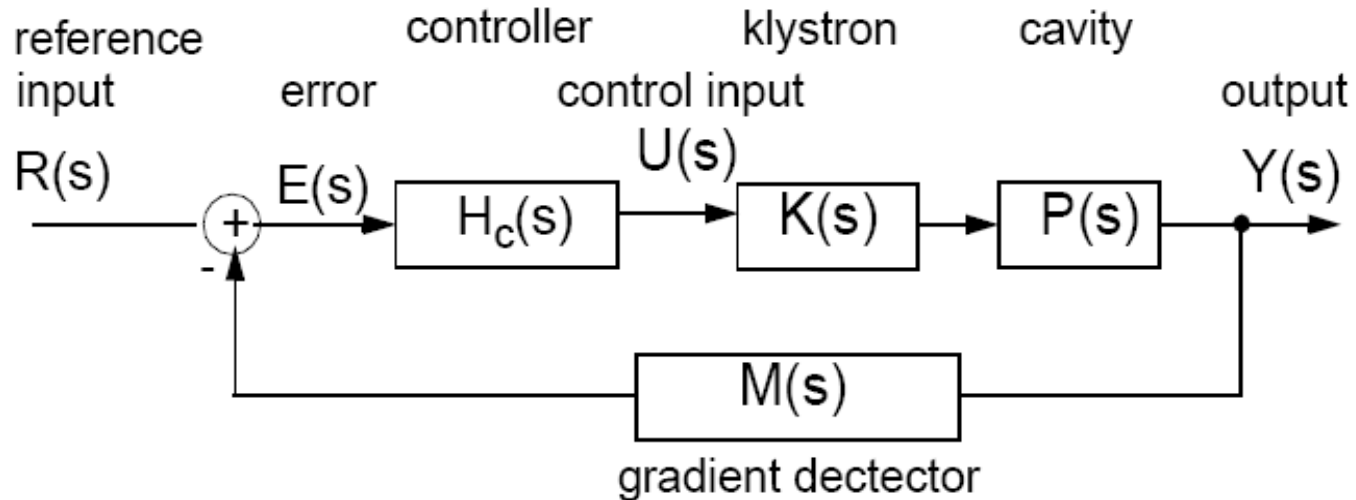

## Questions:

- How well the output will track the reference input in presence of perturbations and noises?
- Is the feedback system stable? What factors will influence the stability?

# Sensitivity of the Field Error to System Parameter Variations



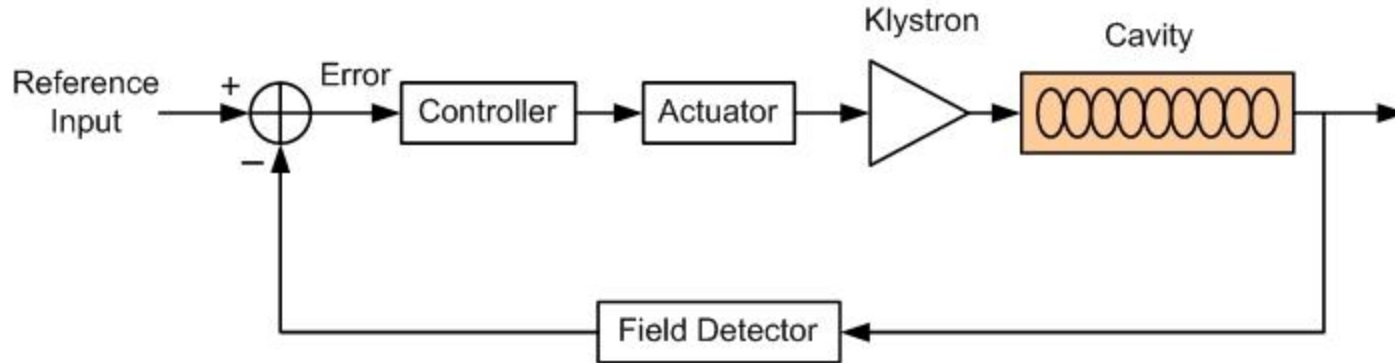

- Gain and phase errors of the klystron
- Amplitude and phase errors of cavities due to Lorentz force detuning and microphonics

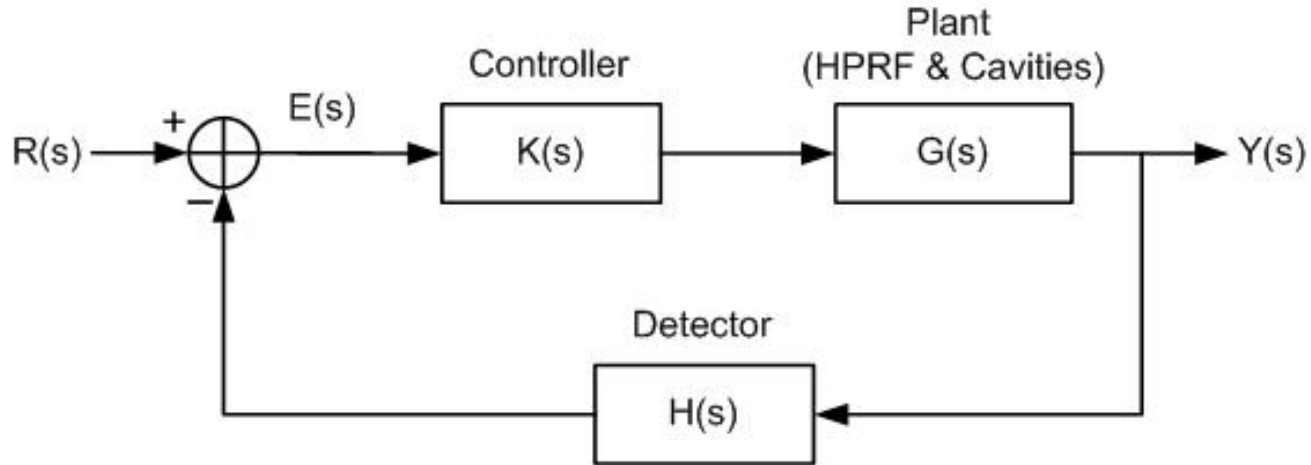

$$K(s) = K_0$$

$$G(s) = G_0 e^{j\varphi} \frac{\omega_{1/2}}{s + \omega_{1/2} - j\Delta\omega}$$

$$H(s) = \frac{\omega_c}{s + \omega_c}$$

- P controller
- High power RF system is modeled as a constant gain and phase shift as an approximation around the working point
- Cavity transfer function of  $\pi$  mode is considered
- Detector is modeled as a first order low pass filter



# Effect of System Parameter Variations with Feedback

Closed loop response

$$Y(s) = T(s) \cdot R(s), \quad T(s) = \frac{K(s)G(s)}{1 + K(s)G(s)H(s)}$$

Assume transfer function of the plant is changed

$$\frac{\Delta G}{G} = \frac{\Delta G_0}{G_0} + j\Delta\varphi + \frac{j\Delta(\Delta\omega)}{s + \omega_{1/2} - j\Delta\omega}$$

The error of system output due to the system parameter variations in steady state

$$\left. \frac{\Delta Y}{Y} \right|_{steady\_state} = \frac{1}{1 + K_0 G_0} \cdot \left[ \frac{\Delta G_0}{G_0} + j\Delta\varphi + \frac{j\Delta(\Delta\omega)}{\omega_{1/2}} \right]$$

The effect of the parameter variations is suppressed by a factor of the loop gain  $(1 + K_0 G_0) \gg 1$

# Sensitivity of the Field Error to Noises



# LLRF Feedback System Model with Noises

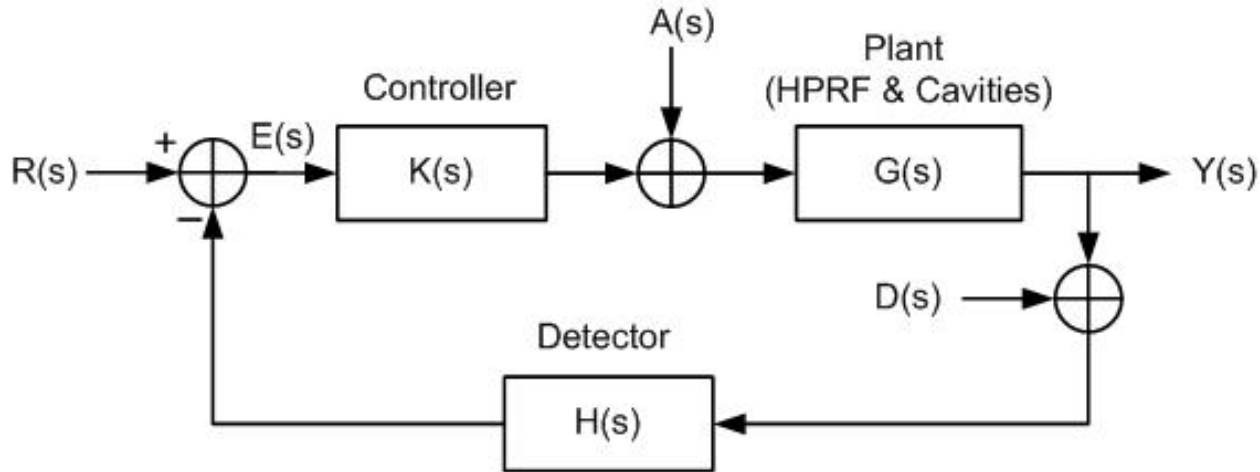

Transfer function of the input noise

$$T_A(s) = \frac{Y(s)}{A(s)} = \frac{G(s)}{1 + K(s)G(s)H(s)}$$

Transfer function of the detector noise

$$T_D(s) = \frac{Y(s)}{D(s)} = -\frac{K(s)G(s)H(s)}{1 + K(s)G(s)H(s)}$$



# Noise Transfer in Frequency Domain

## Parameters for the bode plot:

- Cavity detuning = 0
- Half bandwidth = 216Hz
- Loop gain = 100
- Detector bandwidth = 1MHz

## Conclusion:

- Actuator noise is suppressed by feedback gain
- Low frequency noise of detector is transferred directly to the cavity output; high frequency noise is filtered by closed loop bandwidth and detector bandwidth
- **Reducing the detector noise will be essential to get highly stable cavity field!**

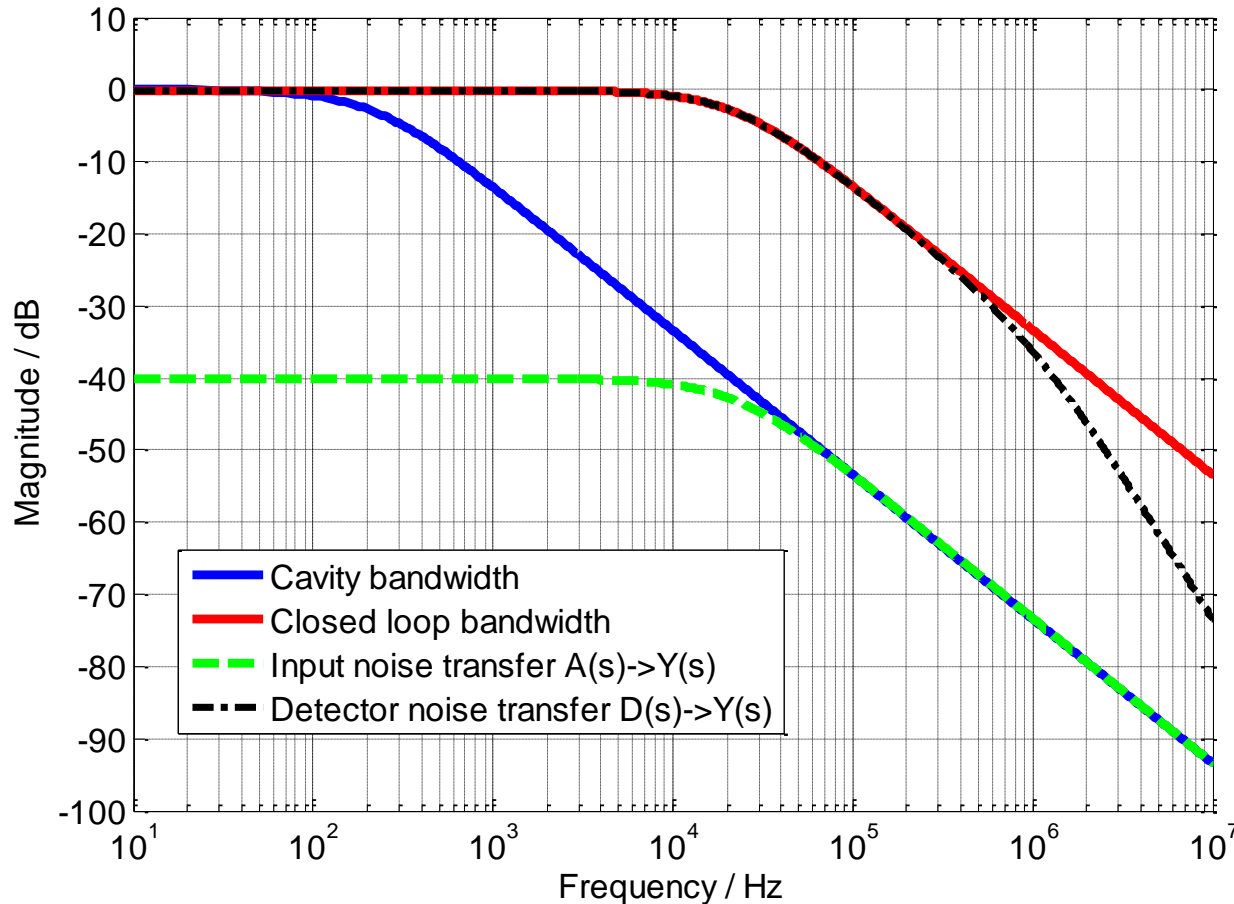

# Feedback Stability

Some major items that concern to the feedback stability:

- Loop gain
- Loop delay
- Loop phase

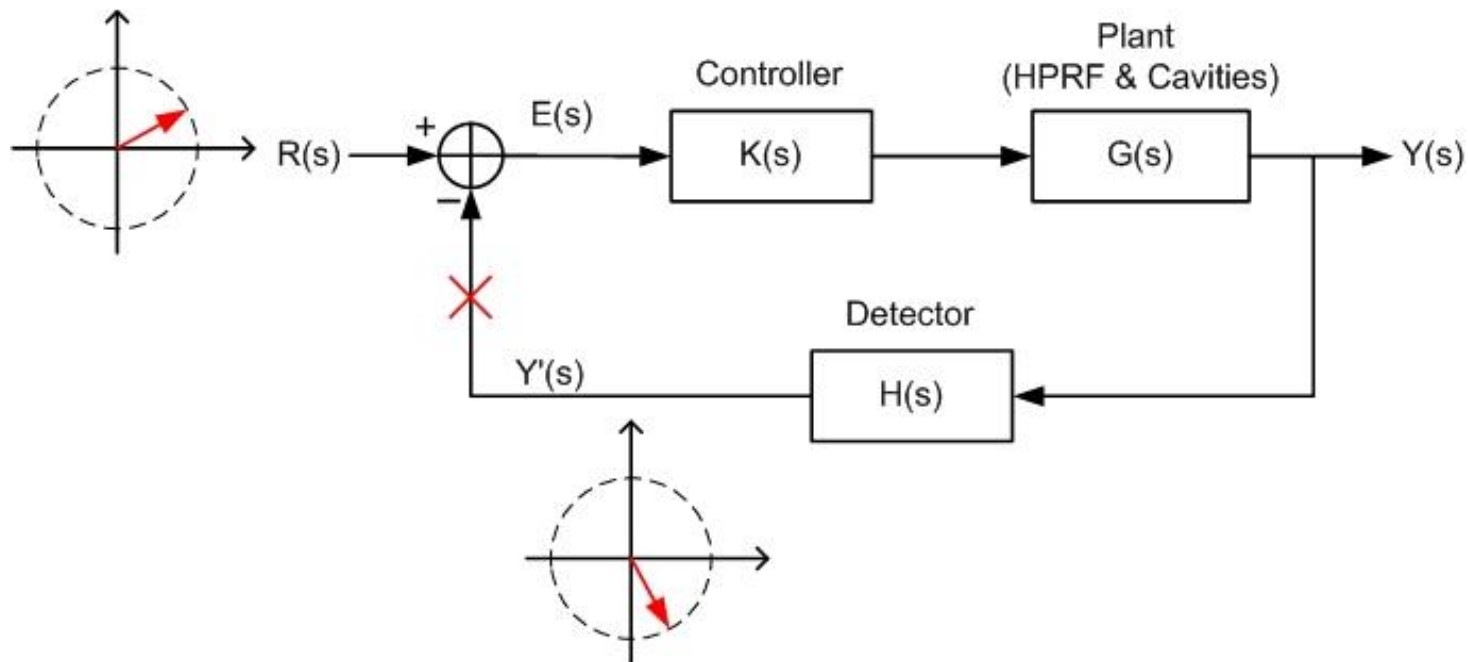





# Field Stability Concerns to Loop Gain

Question: Is the loop gain as higher as better?

It **seems** right. From the discussion before:

$$\left. \frac{\Delta Y}{Y} \right|_{steady\_state} = \frac{1}{1 + K_0 G_0} \cdot \left[ \frac{\Delta G_0}{G_0} + j\Delta\varphi + \frac{j\Delta(\Delta\omega)}{\omega_{1/2}} \right]$$

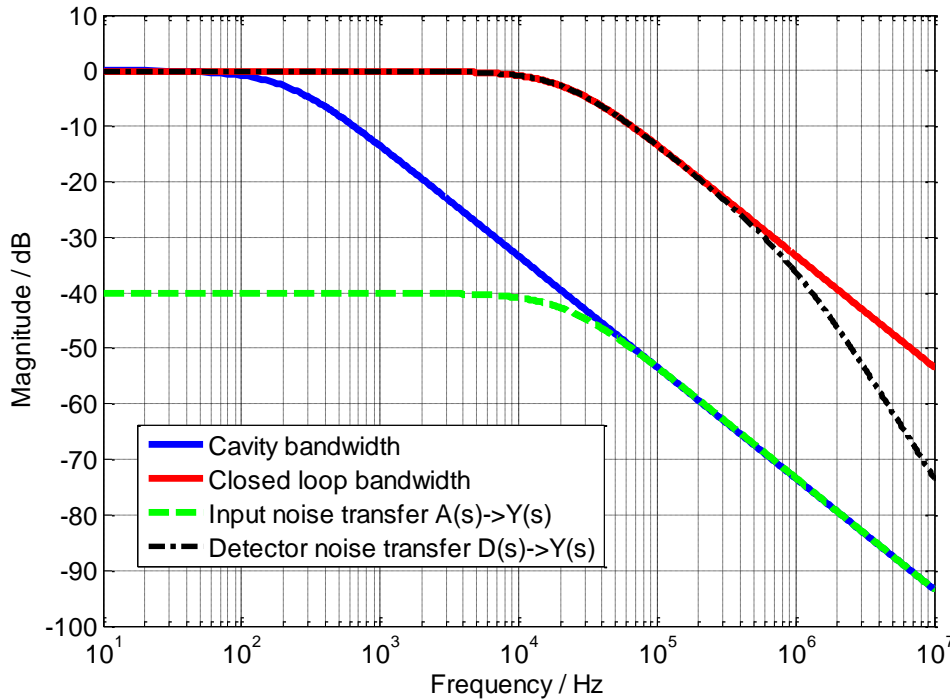

But with higher gain:

- More detector noise goes into the cavity
- There will be overshoot and rings in transient response in presence of loop delay
- Feedback becomes unstable if the gain exceeds the gain margin

So, loop gain is not as higher as better, a compromised gain should be selected!

# Gain Sweep at ACC1 of FLASH

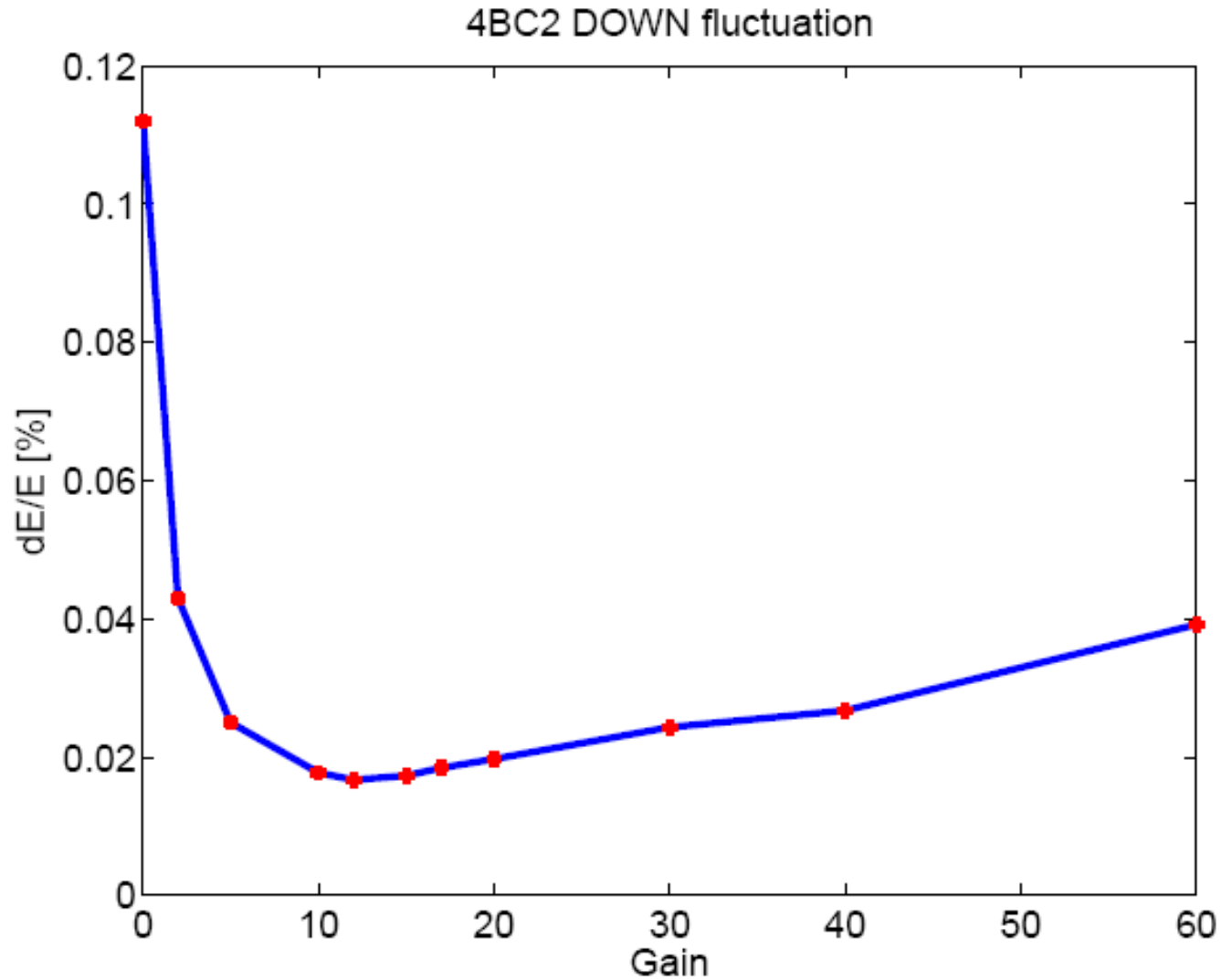



# Cornell RF Control Test at the TJLab FEL

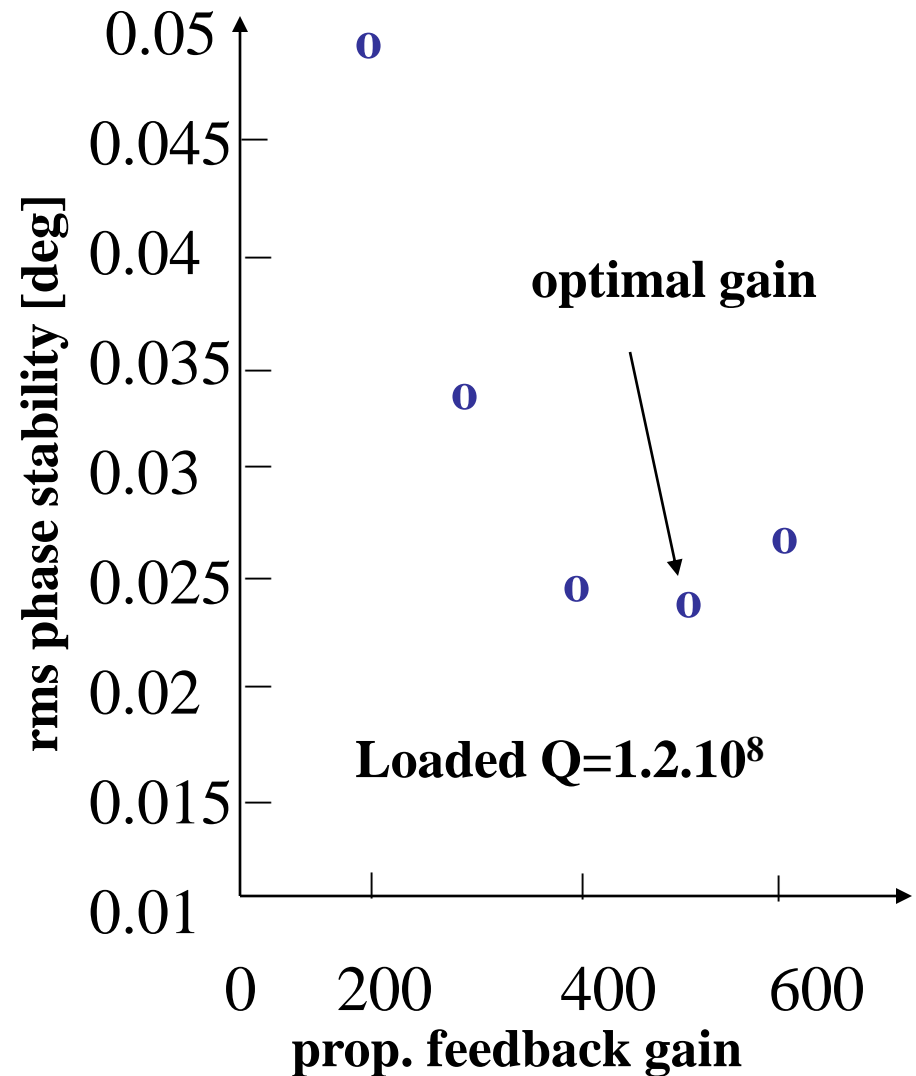
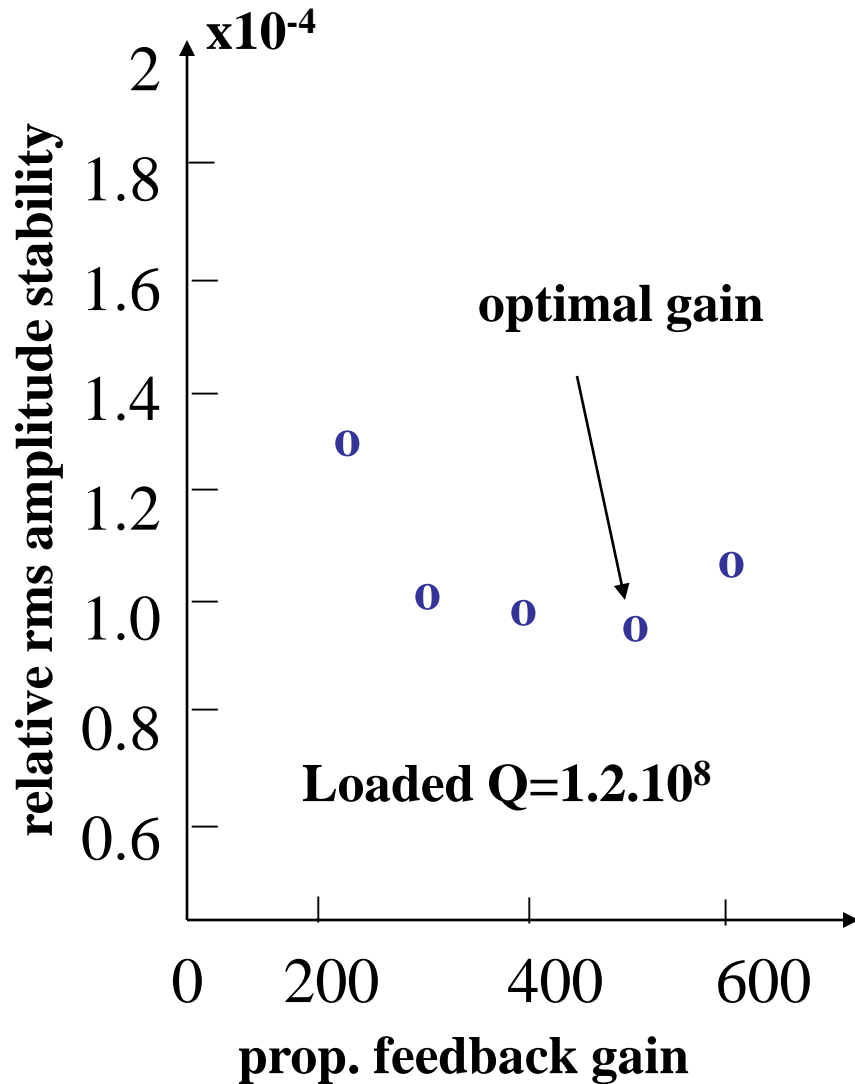



# Feedback Stability at ACC4-6 of FLASH with Different Gain

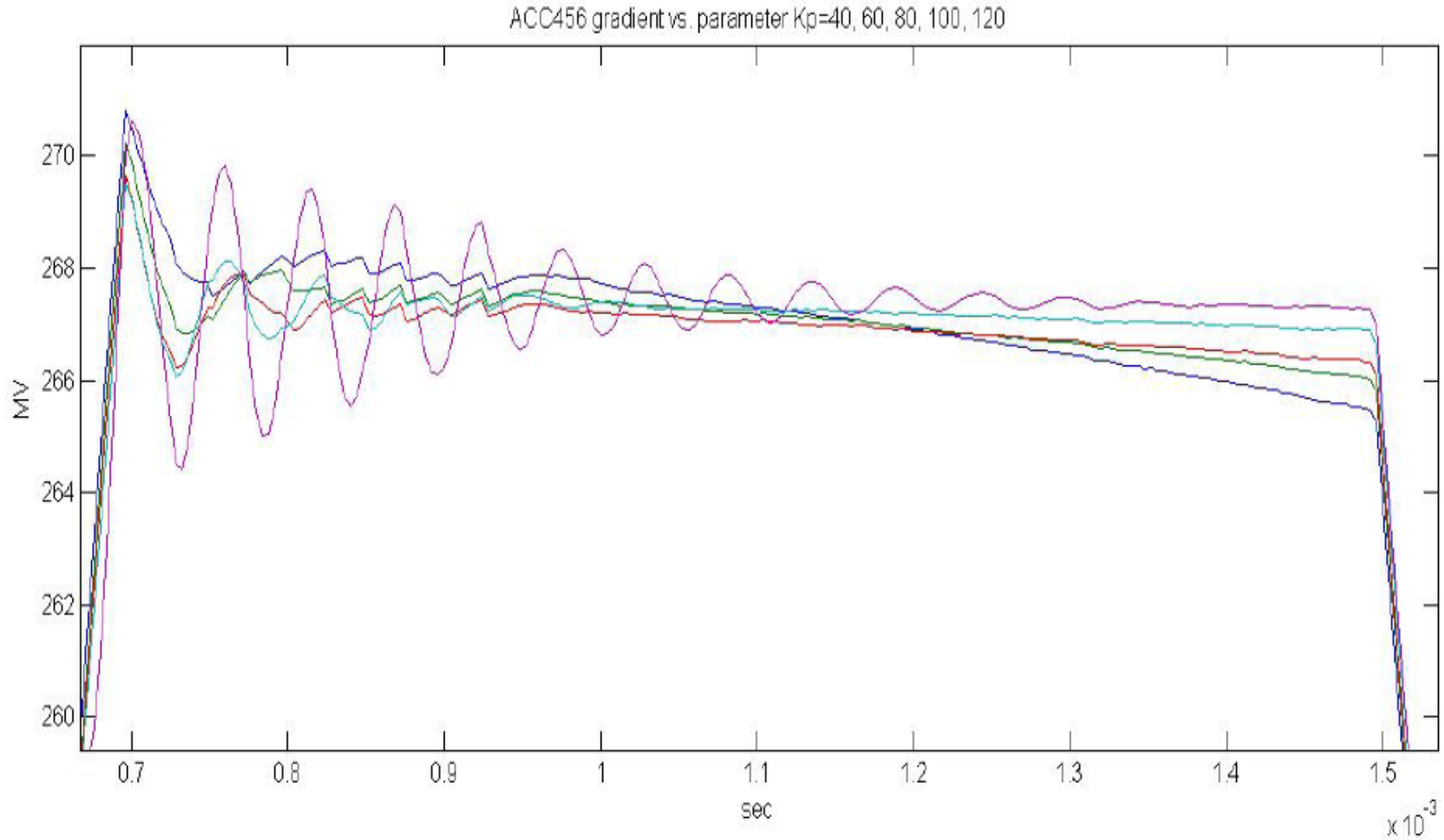



# Gain Margin and Phase Margin with Loop Delay

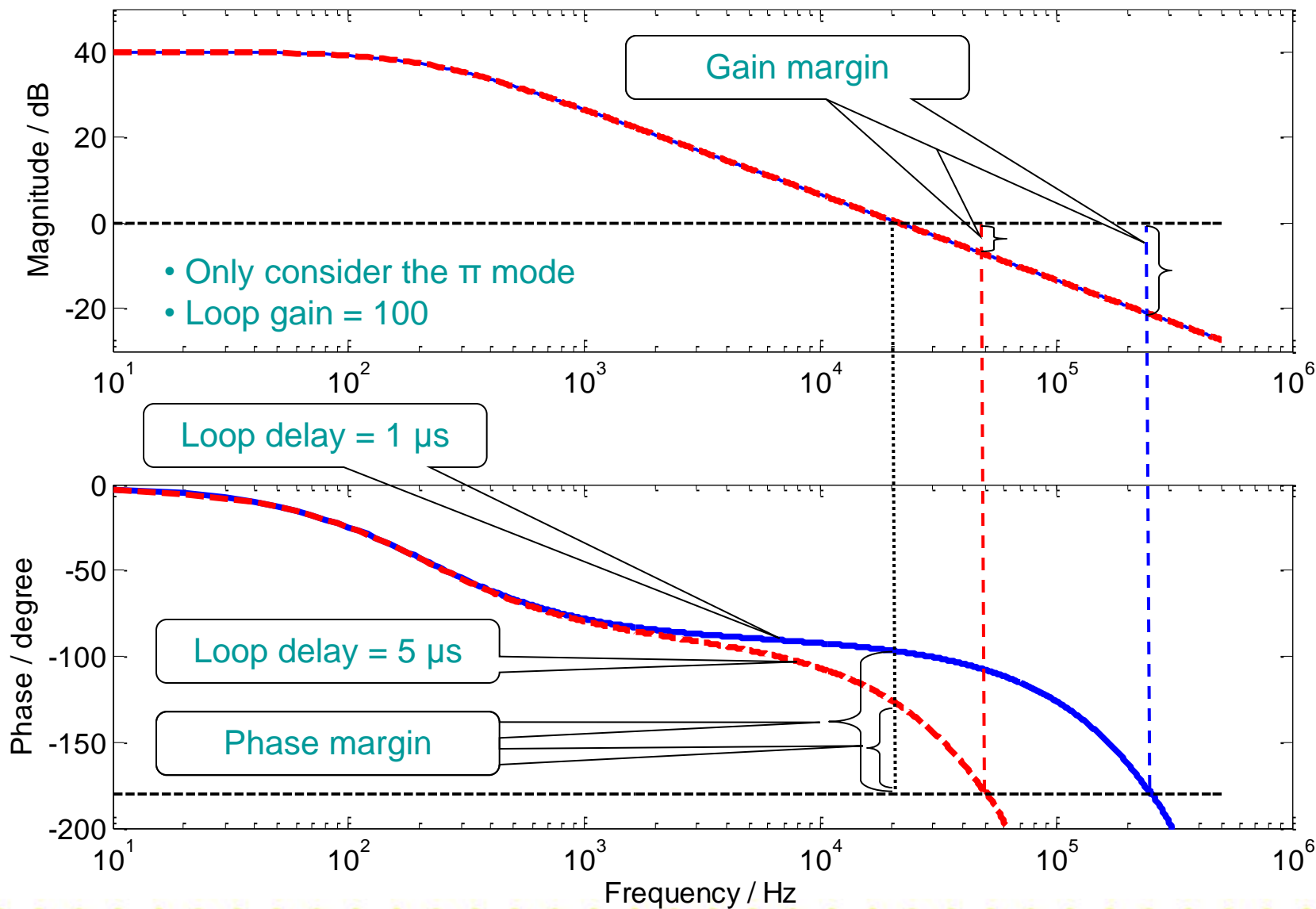



# Field Stability Concerns to Loop Delay

Question again: Is the loop delay as smaller as better?

It **seems** right, because lower loop delay will decrease the overshoot and rings of the transient response and increase the gain margin.

But if there is other pass band modes:

- Instability happens for certain delays (even zero delay)!

# Cavity Model with Pass Band Modes

$$H_{cav}(s) = \sum_{n=1}^9 (-1)^{n-1} H_{n\pi/9}(s) = \sum_{n=1}^9 (-1)^{n-1} \frac{2\omega_{1/2, n\pi/9}}{s + \omega_{1/2, n\pi/9} - j\Delta\omega_{n\pi/9}}$$

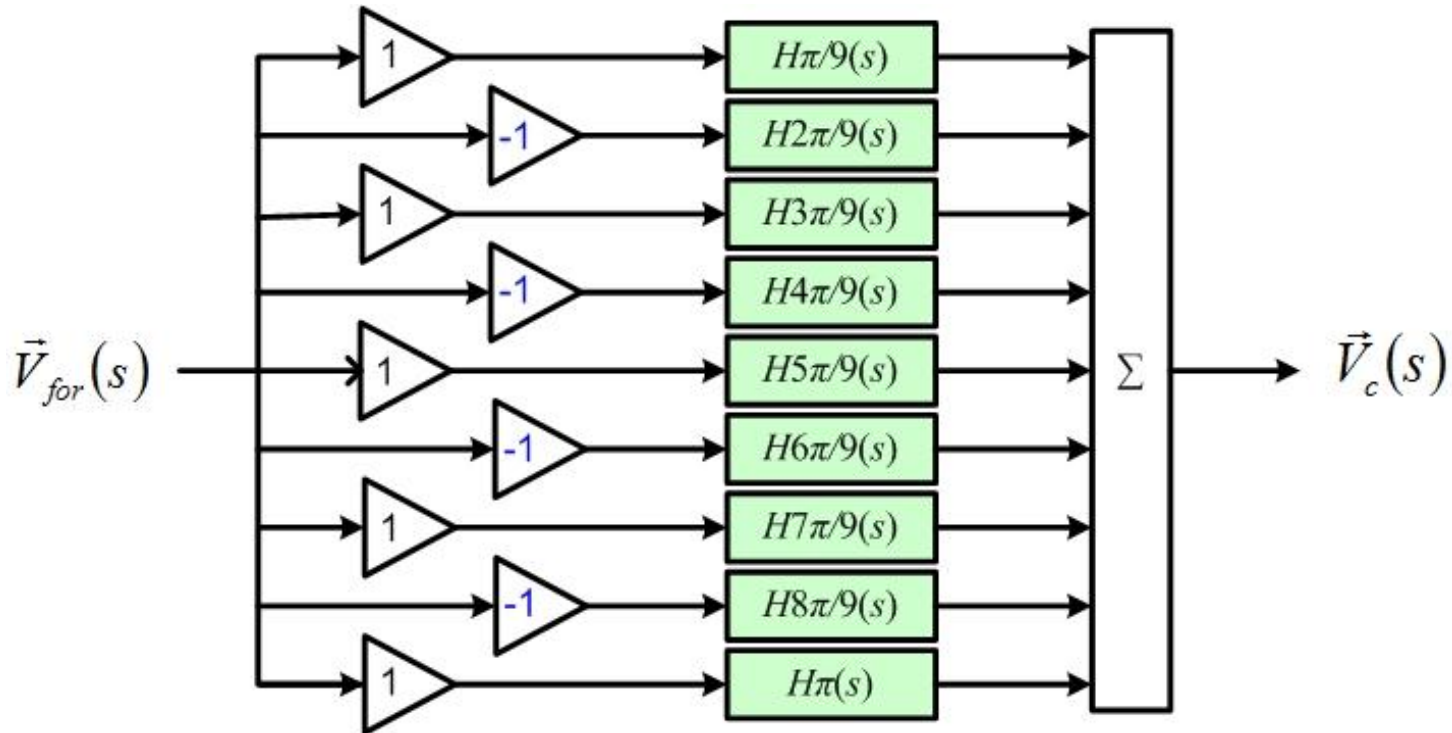

$8\pi/9$  mode is the most serious one to influence the feedback stability.



# Gain Margin and Phase Margin with Loop Delay and $8\pi/9$ Mode

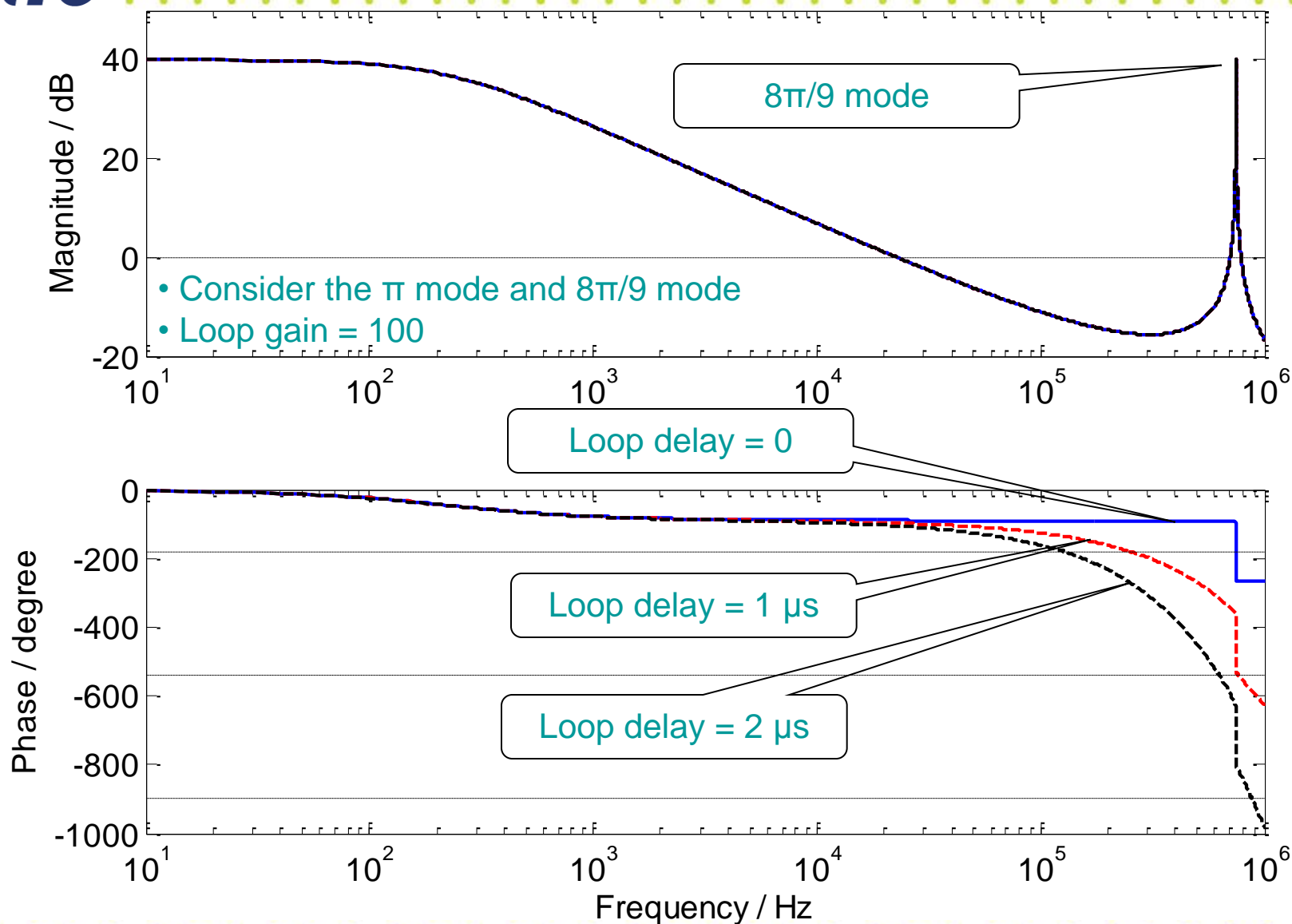





# Gain Margin and Phase Margin with Loop Delay and $8\pi/9$ Mode (zoom near the $8\pi/9$ mode.)

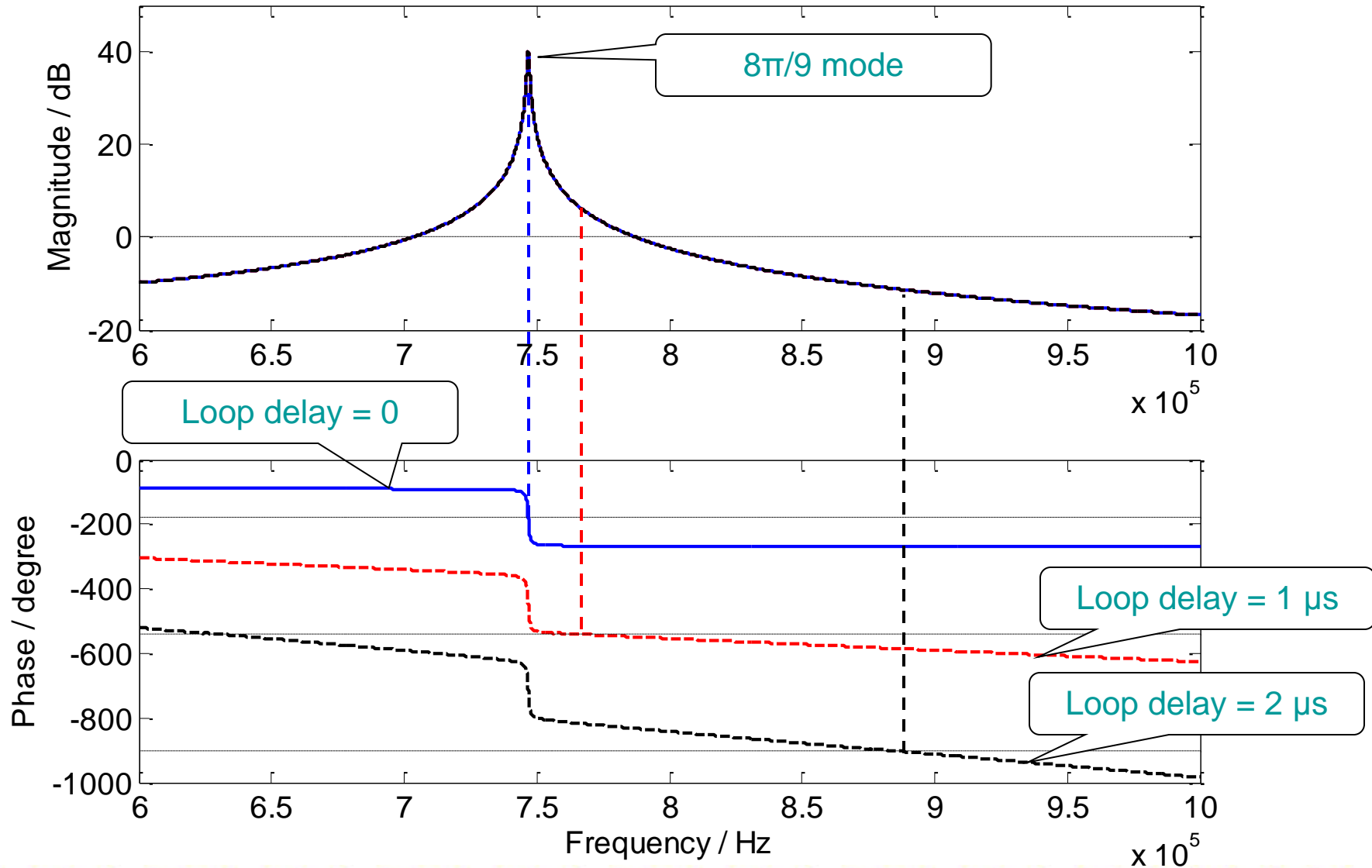



# Feedback Stability with Different Loop Delay Tested at ACC1 of FLASH

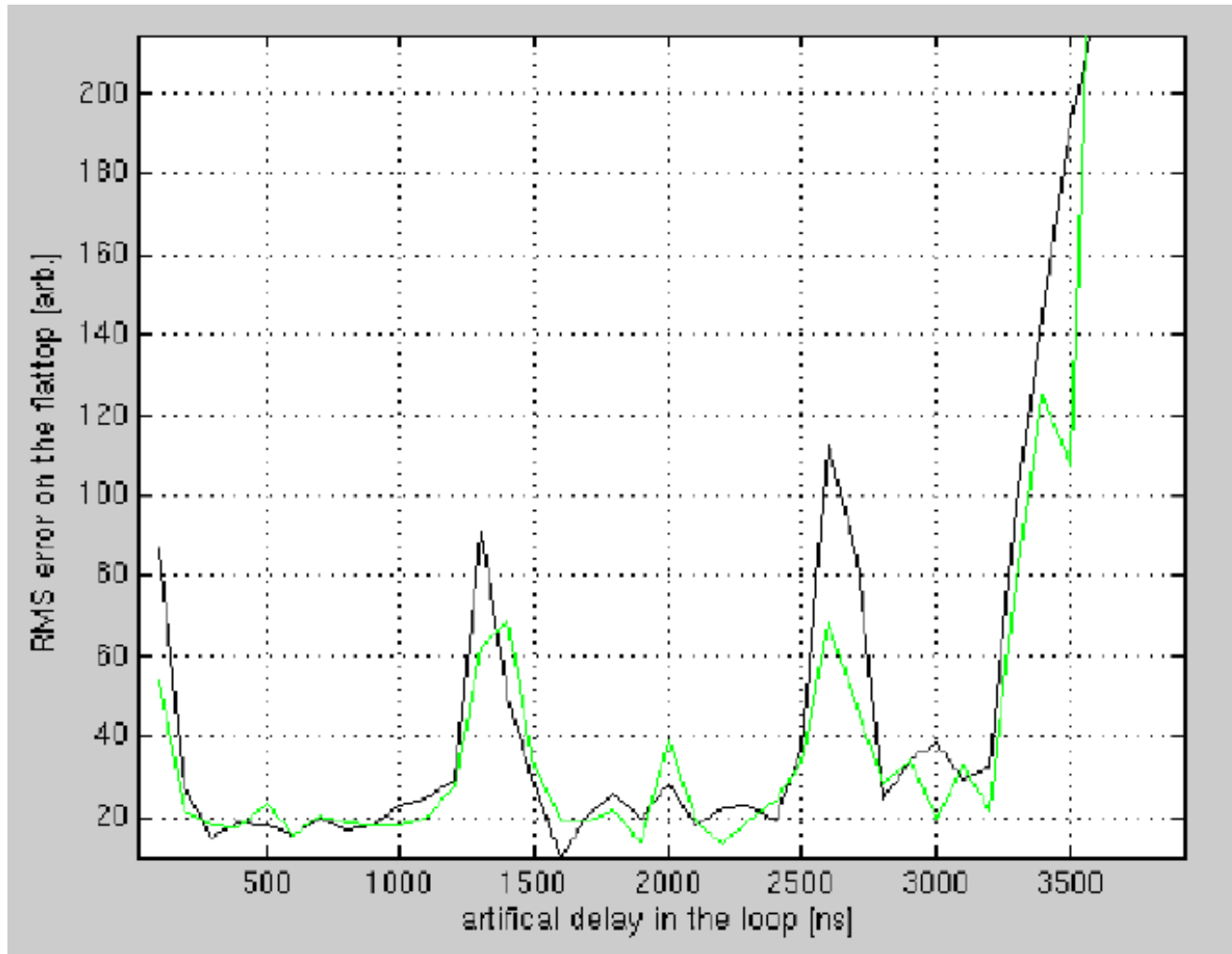

# Summary of the Effect of Loop Gain and Loop Delay

- Loop delay of the feedback system should be adjusted in order to avoid the instability caused by the pass band modes, and beside that, it should be as small as possible
- Compromised loop gain should be selected taking into account the disturbance suppression and the noises of the detector

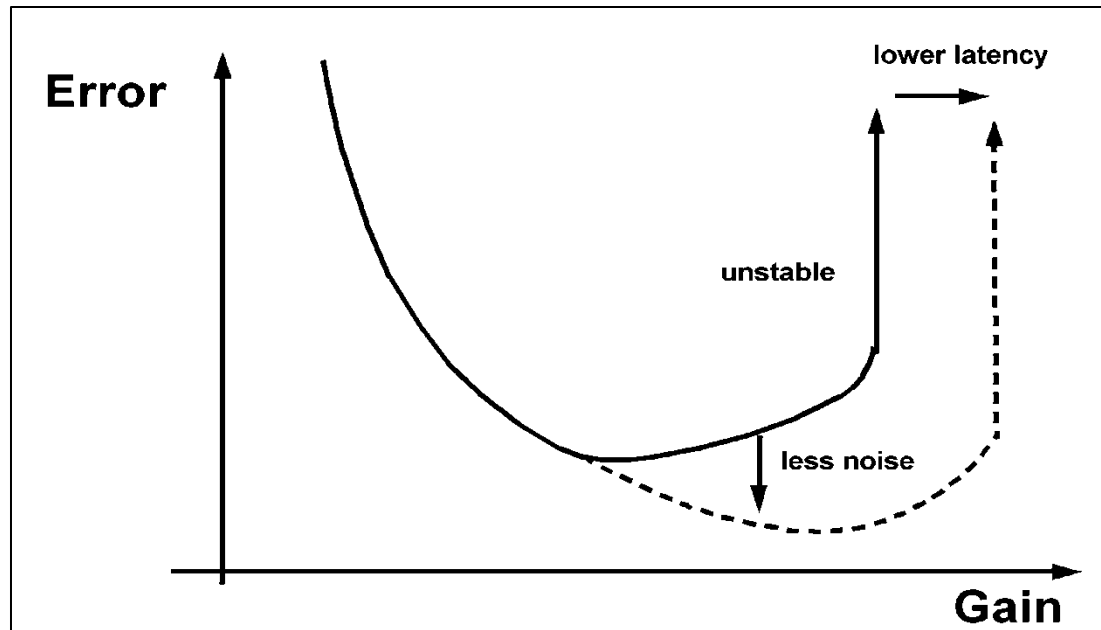

# How Loop Phase Affect Feedback Stability?

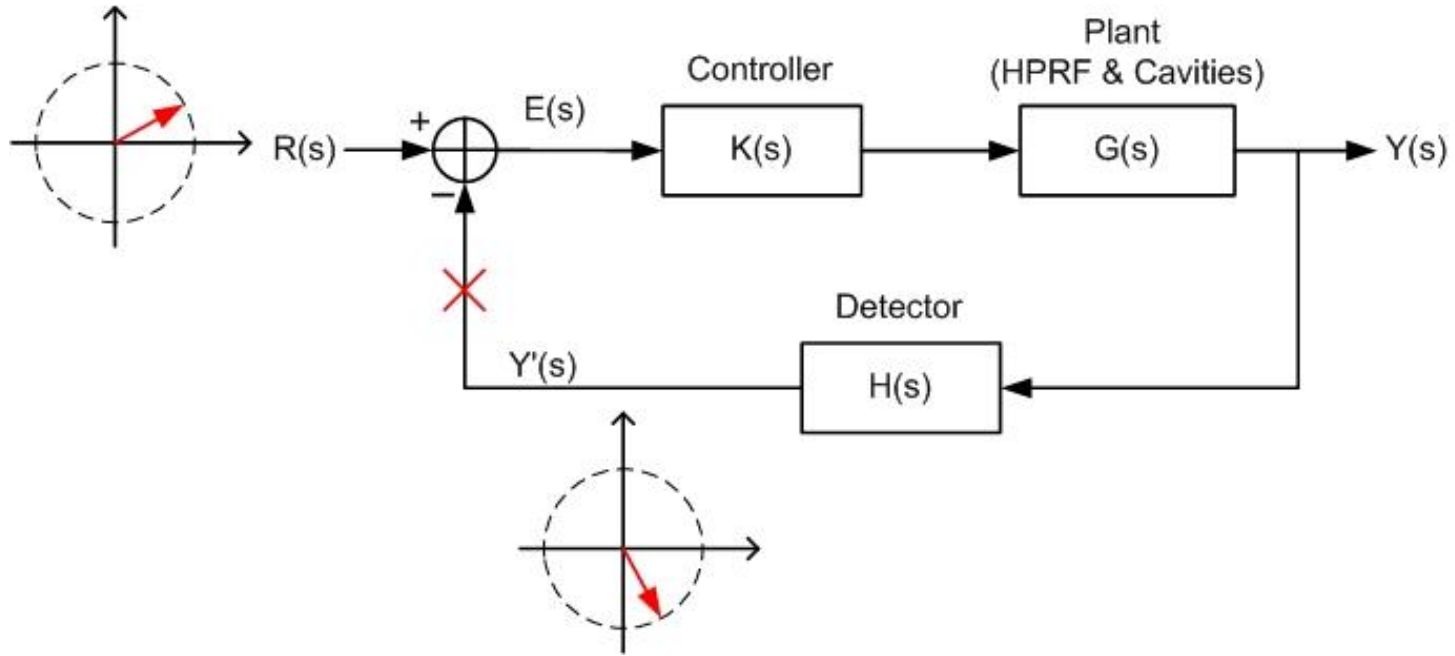

Stability Range:  $[-90^\circ, 90^\circ]$

# Test at ACC1 of FLASH

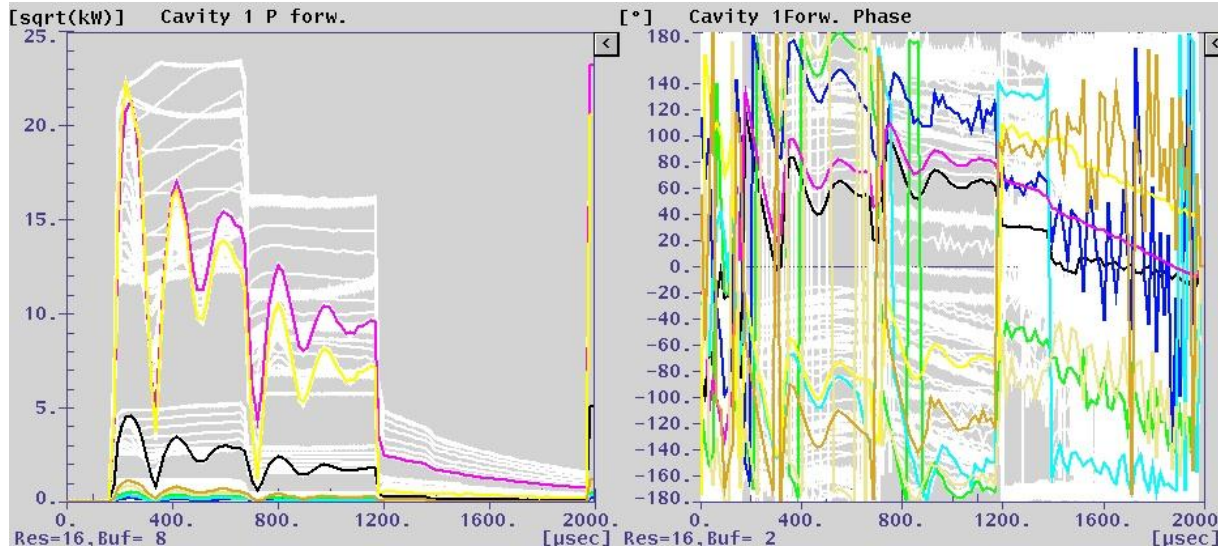

With feedback and feed forward on

The loop phase is changed in negative way by about 70 degree

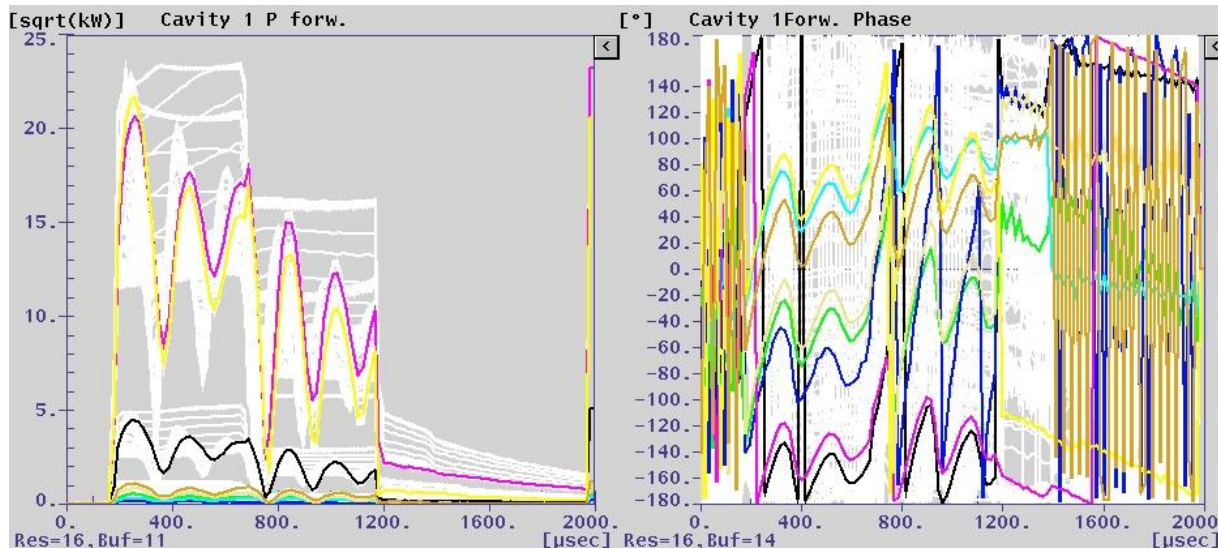

With feedback and feed forward on

The loop phase is changed in positive way by about 80 degree

In this part, we have learnt:

- The RF system parameter variations can be suppressed by the loop gain
- The input noise can be suppressed by the loop gain
- The detector noise will go into the cavity field within the closed loop bandwidth
- The loop gain should be selected as a compromise between the perturbation suppression and noise level
- The loop delay should be selected to avoid the instability caused by other pass band modes
- The loop phase should be in the range of  $-90$  degree to  $90$  degree for stability

- [1] E. Vogel. High Gain Proportional RF Control Stability at TESLA Cavities. Physical Review Special Topics – Accelerators and Beams, 10, 052001 (2007)
- [2] M. Hoffmann. Development of A Multichannel RF Field Detector for the Low-Level RF Control of the Free-Electron Laser at Hamburg. Ph.D. Thesis of DESY, 2008