

Cryogenic System of Interaction Region (SiD, ILD, QD0, QF1, Crab Cavity) in the Japanese Mountain Site

**WebEx meeting : ILC Central Region Cryogenics
June 1st, 2012**

**IPNS/Cryogenic Group
T. Okamura, Y. Makida, M. Kawai**

Table of Contents

Cryogenic facility configuration for interaction region except dumping ring are proposed.

1. Cryogenic facility layout including dumping ring
2. Two Conceptual cooling schemes (Plan-A & Plan-B)
 - ✓ Layout
 - ✓ flow diagram
 - ✓ Advantage and disadvantage
3. Transfer Tube (TRT)
 - ✓ Rigid type TRT, Flexible type TRT
4. Summary
 - ✓ cryogenic strategy in the Japanese Mountain Site

Overall layout of Interaction Region

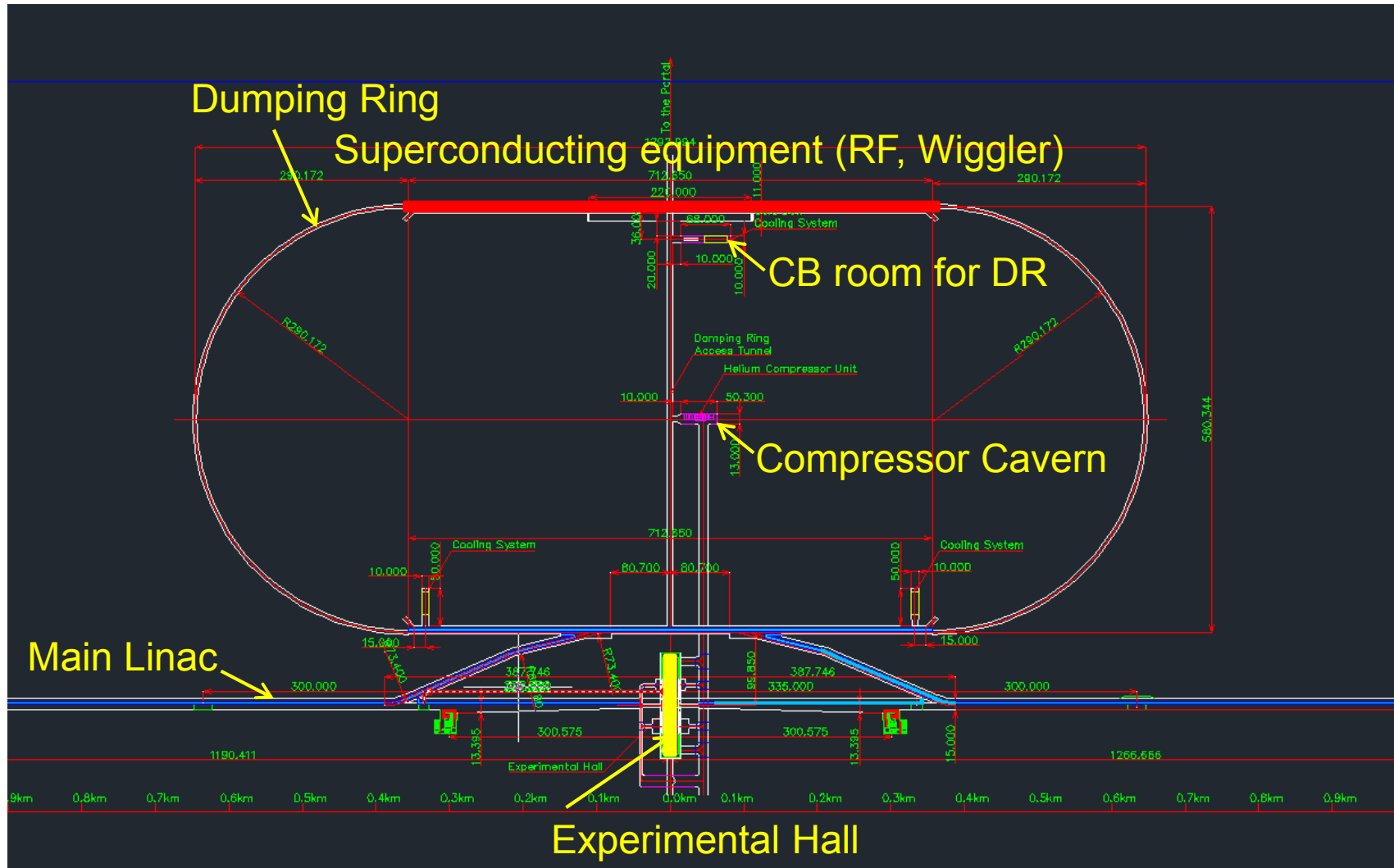

(Superconducting instruments SID, ILD, QD0, QF1, CC)

Cryogenic overall block diagram example

Cryogenic system for IR including dumping rings is composed of four sections.

1. Compressor cavern
2. CB cavern for DR
3. Experimental Hall for detectors.
4. Helium buffer tank section.

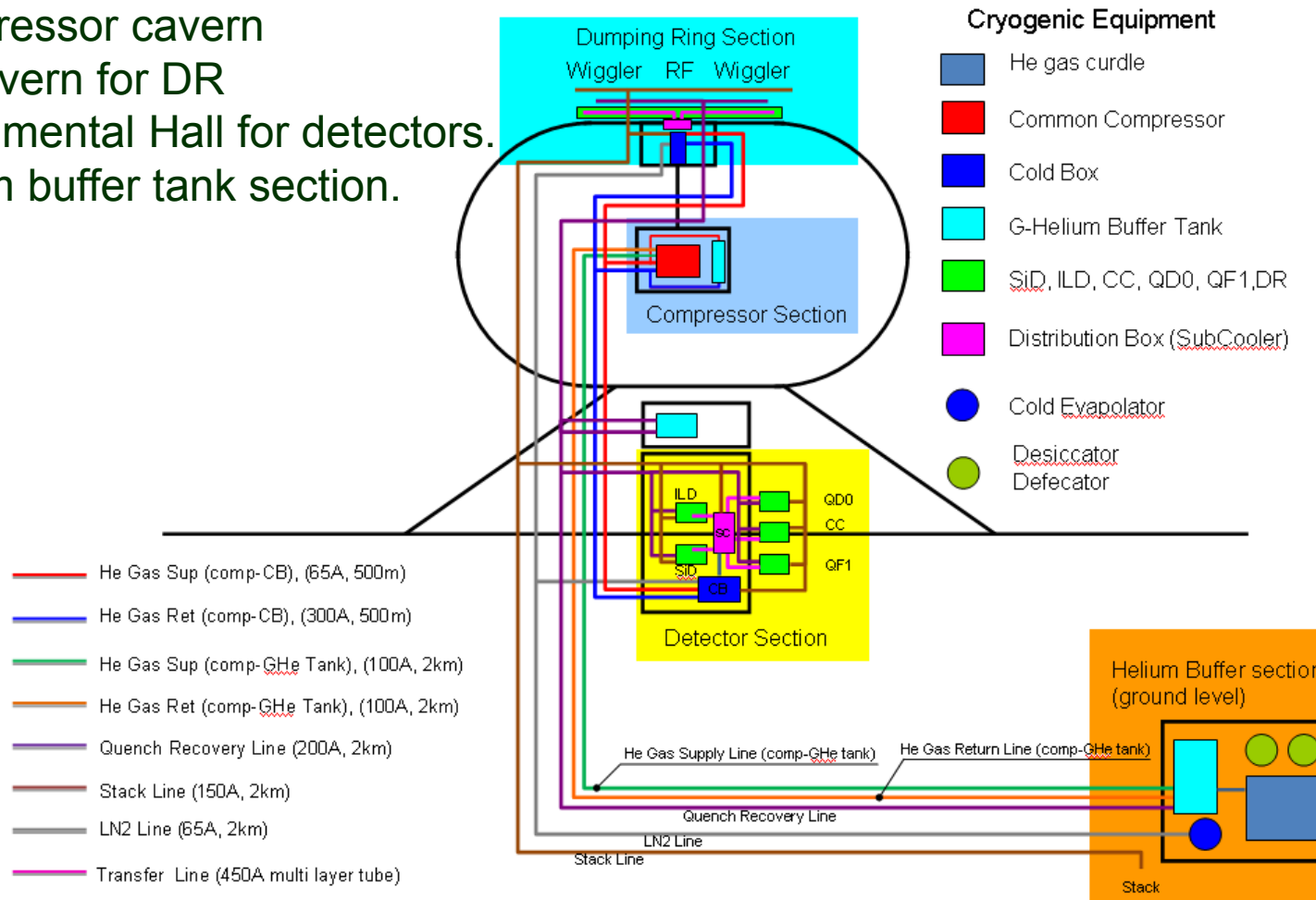

Cryogenic system for experimental hall (SiD, ILD, CC, QD0, QF1) except dumping ring will be introduced.

Equipment installed in each region

Compressor section (Compressor cavern)

- All Compressors for detectors, QD0, QF1, CC and DR
- Helium Buffer tank (in order to control pressure fluctuation) ~ Volume ~ 100 m³

Discussion Item

Experimental Hall

- **Superconducting instruments (SiD, ILD, QD0, QF1, CC) are installed.**
- **Cold Box (Single or more cold box? → Discussion Item)**
- **Subcooler for Liquid Helium and Superfluid Helium (Distribution Box)**
- **Liquid Nitrogen Equipment for precooling**

Dumping Ring section

- Cold Box for DR
- Distribution Box (subcooler)
- Liquid Nitrogen Equipment for precooling (Gas-Liquid Separator).

Helium gas buffer tank section

- Helium buffer storage tank for magnet quench
- High purity helium gas curdle
- Purifier, Desiccator
- Cold Evaporator

Physical relationship of Superconducting Equipment

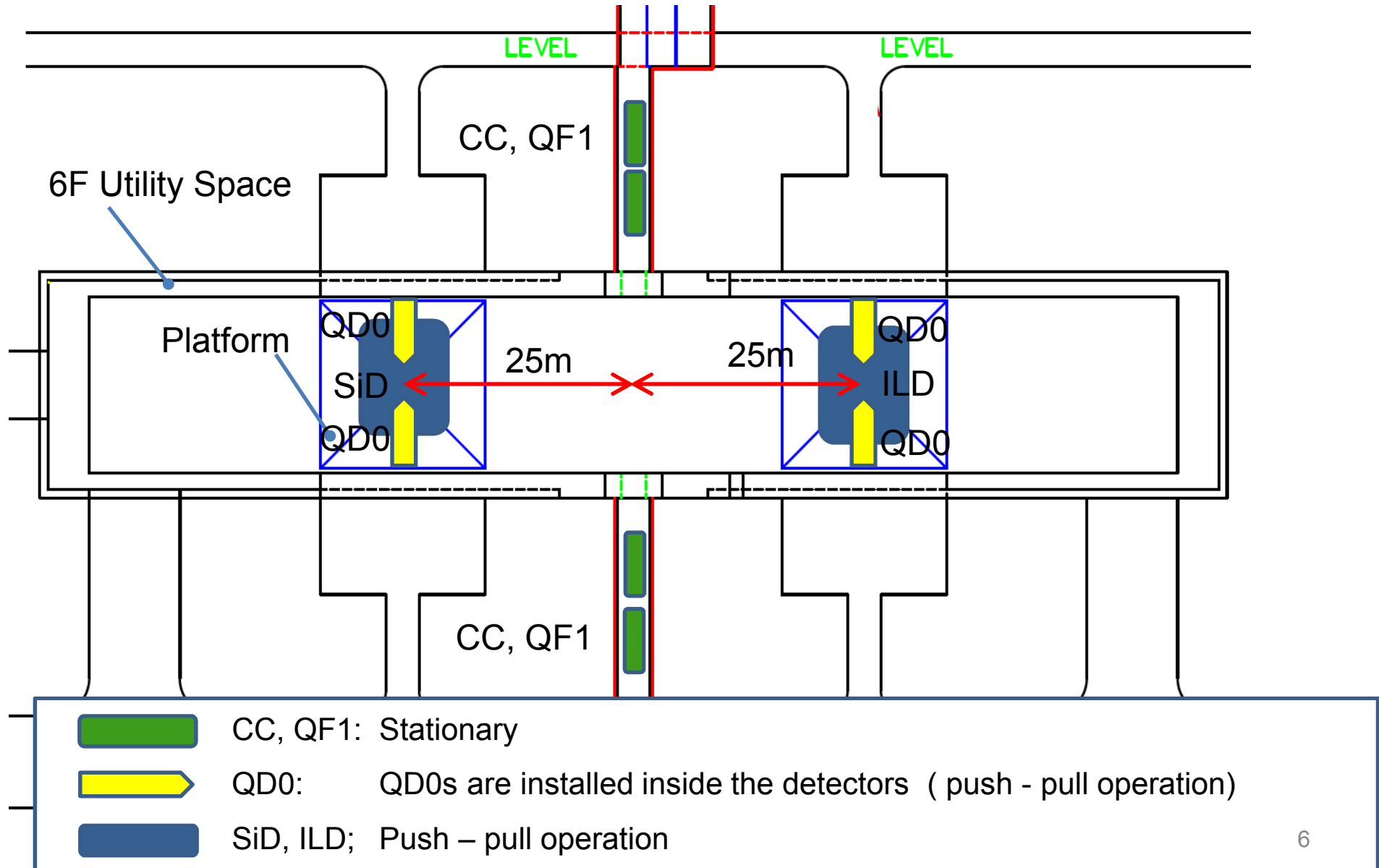

Cooling requirements for superconducting equipment

Superconducting equipment	Coolant condition	Heat Load
SiD	Two phase flow (4.5 K)	400 W @ 4.5 K
ILD	Two phase flow (4.5 K)	400 W @ 4.5 K
Crab cavity	Saturated He II (1.8 K ~ 2.0 K)	100 W @ 2.0 K
QD0	Pressurized He II (1.8 K ~ 2.0 K)	100 W @ 2.0 K
QF1	Pressurized He II (1.8 K ~ 2.0 K)	100 W @ 2.0 K
Dumping ring		

- We have to reconsider actual thermal load for these equipment.
- To determine actual cooling capacity of CB, safety factor and extra heat load such as TRT has to be considered.

Cryogenic cooling schemes for interaction region

How to cool down SiD/ILD, QD0, QF1 and crab cavity?

- **Plan-A : Single Cold Box**

- Detectors (SiD, ILD), Crab Cavity, QD0, QF1
(Cold box is installed on 6F utility space.)

→ Flexible type transfer tubes for push-pull operation

- Limit minimum bending radius for TRT

- **Plan-B : Three Cold Boxes (CB1, CB2, CB3)**

- CB1= SiD and QD0 (Cold box is installed on the platform for SiD.)
- CB2= ILD and QD0 (Cold box is installed on the platform for ILD.)
- CB3= CC and QF1 (Cold box is located at 6F utility Space.)

→ Conventional type transfer tube

Cryogenic Layout in the experimental Hall (Plan-A)

- ✓ Cold box and two distribution boxes are installed on 6F.
- ✓ It is essential to use flexible type TRT between distribution boxes and detectors.

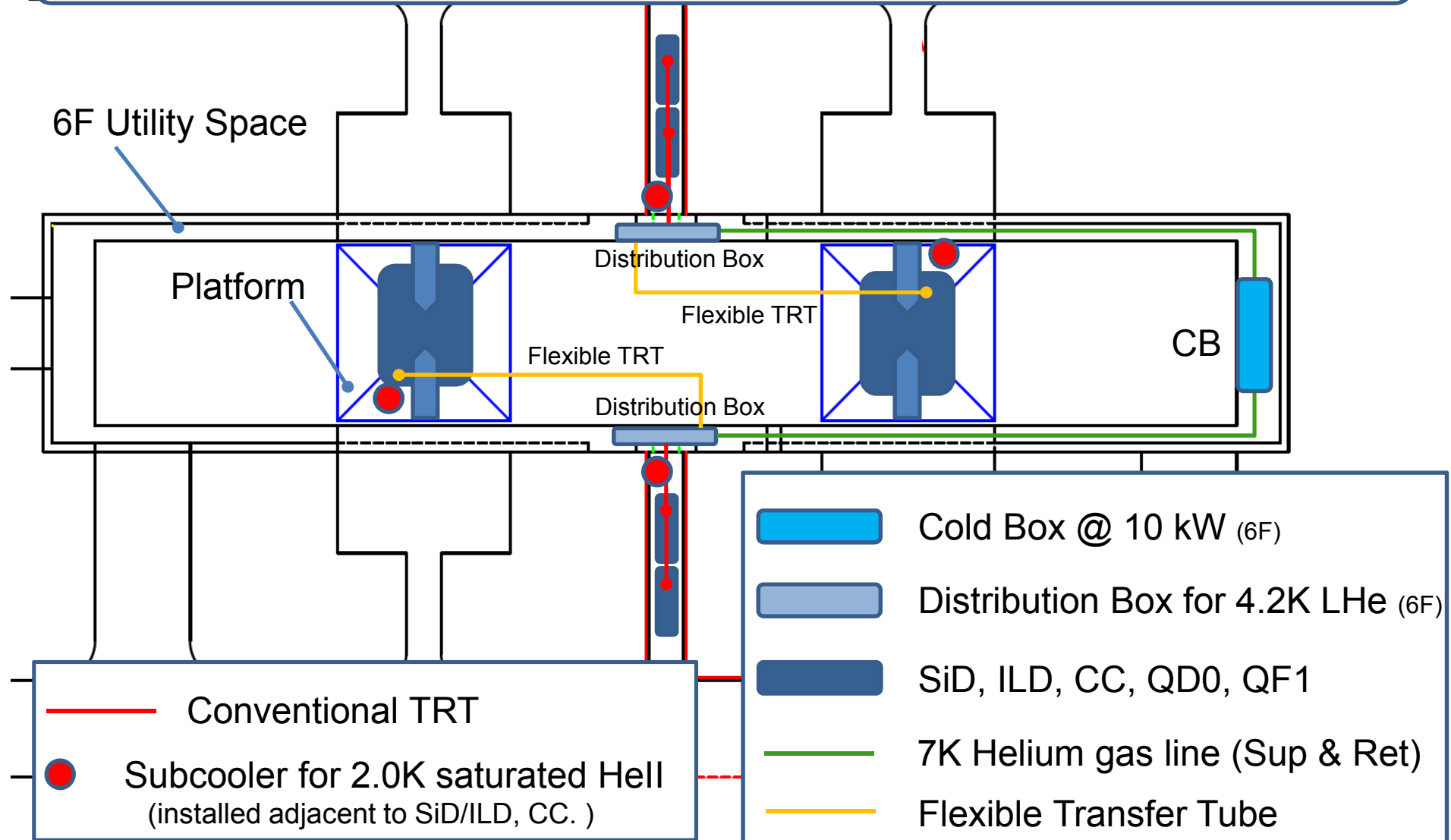

Schematic 3D view of Plan-A

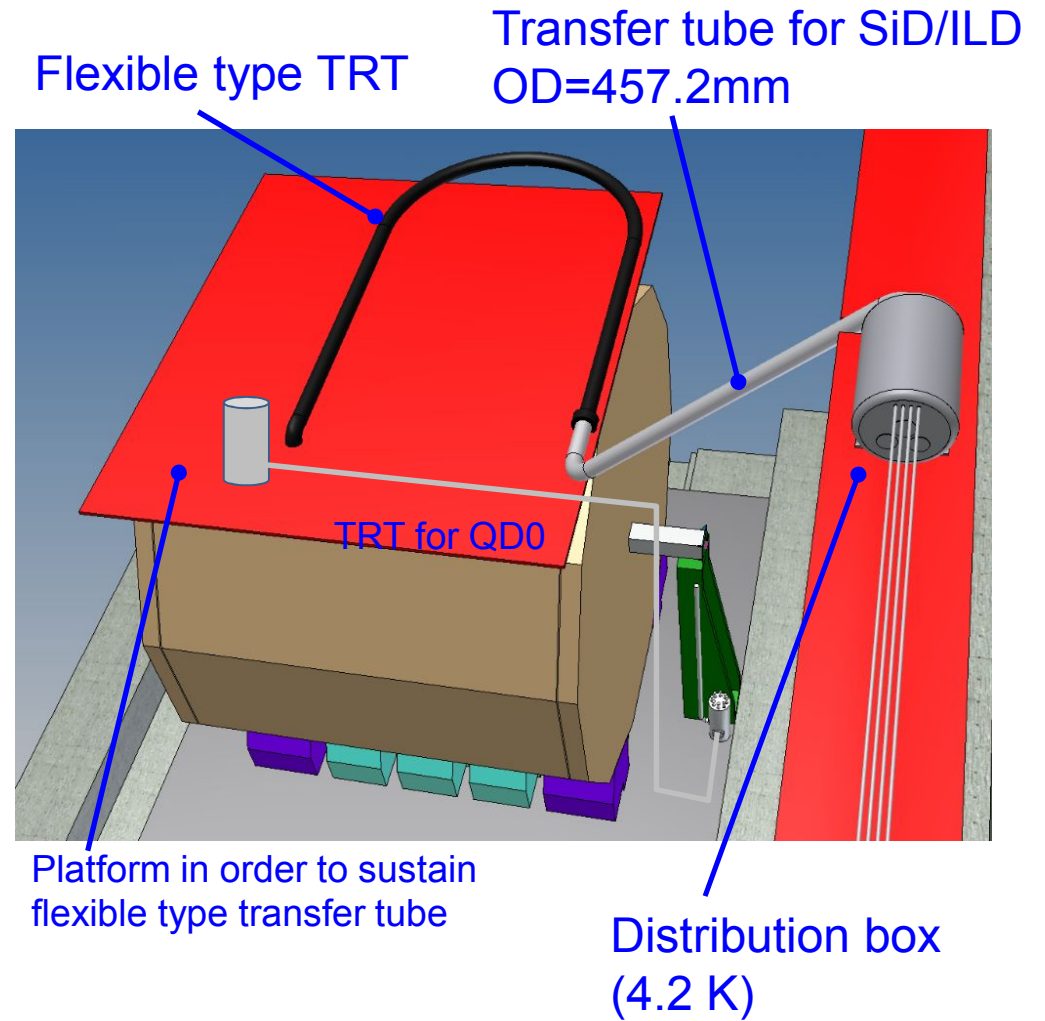
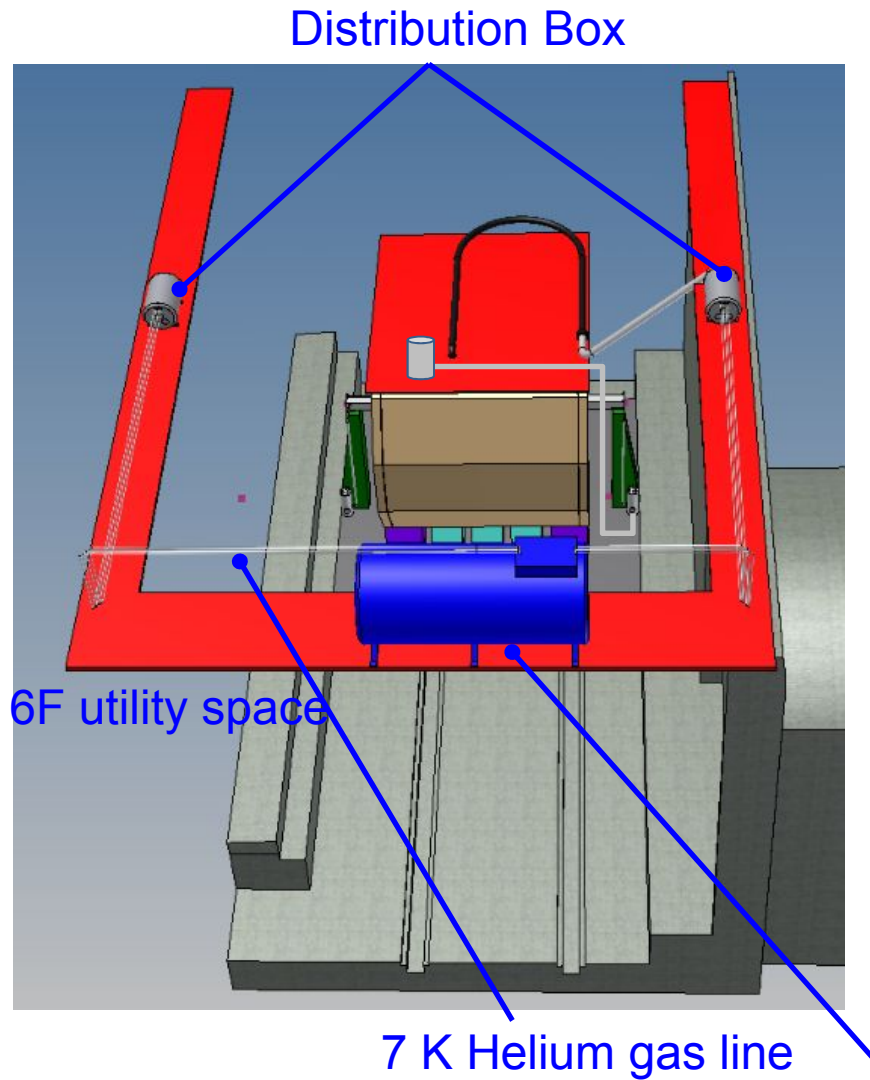

Cold box @ 10 kW
D=5m, H=6m, W=11.3 m

Cryogenic Layout in the experimental hall (Plan-B)

- ✓ CB3 and distribution boxes for CC and QF1 are installed on the 6F.
- ✓ CB1, 2, distribution boxes and PSs are installed on the each platform for detector
- ✓ Laid down methods for Helium gas and quench recovery line have to be considered.
 - ✓ Ordinary flexible tube (bending radius ~ 0.7 m)
 - ✓ Removable fixed tubes are adopted during push-pull operation.

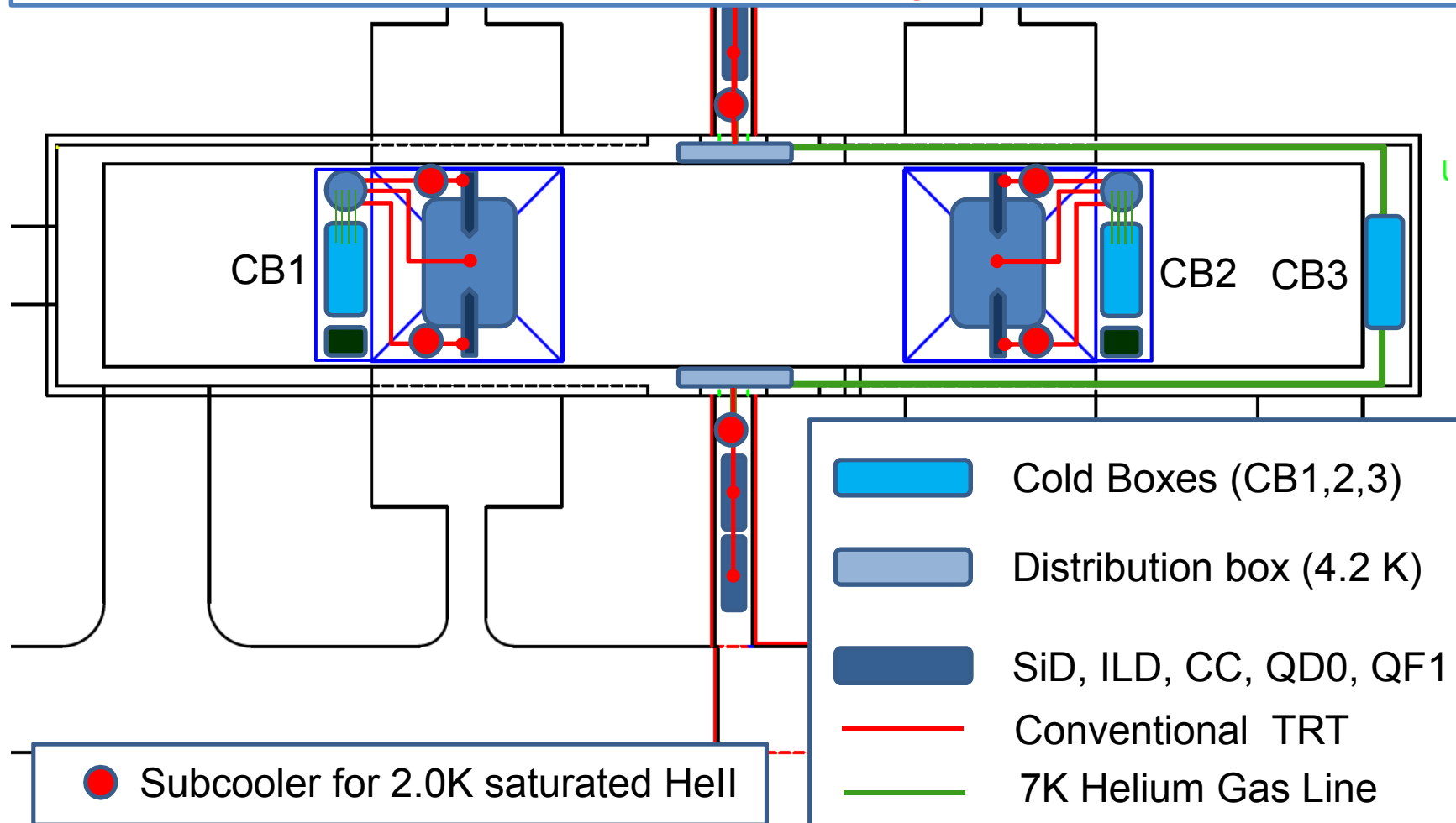

Schematic 3D view of Plan-B

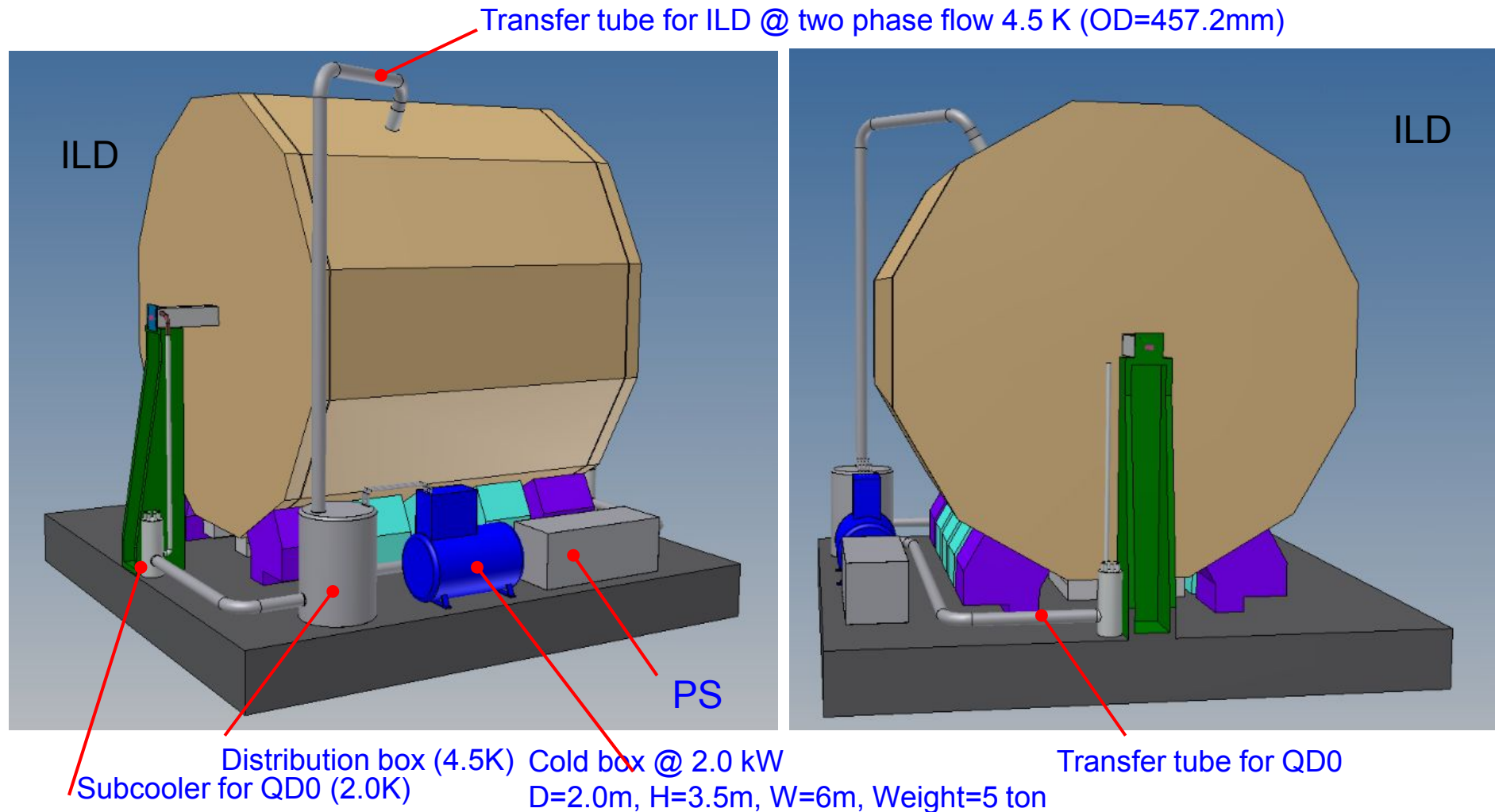

Vibration Reduction Method

- Optimization of support post for QD0 by means of modal analysis
- Application of high vibration reduction material such as D2052 etc.

The optimal location of cold box has to be reconsidered.

Advantage and Limitations for each plan

Plan-A

(advantage)

1. Maintenance and assembly of detector and cold box can be performed independently.
2. Maintenance of cold box is simple because control point and equipment such as valves are not so much.

(disadvantage)

3. **Flexible Type TRT has to be applied between cold box and detectors (SiD/ILD, QD0).**
 - **Minimum bending radius of flexible TRT will tend to be large. Large space for flexible TRT has to be required.**
4. **Fabrication cost is much higher than conventional TRT.**
5. Cooling capacity tends to become large compared with actual heat load depending on the situation. In such case, thermal balance has to be maintained by means of heater installed in the subcooler. It is hard to optimize cooling operation.

Plan-B

(advantage)

1. **There is no need to use the flexible type TRT.**
2. Cryogenic Control to keep steady state is quite simple because it is less control point of each refrigerator and cold box is independent of one another.
3. It is easy to perform cooling optimization and power saving operation depending on the situation.

(disadvantage)

1. Confliction between cryogenic facility and detector will frequently occur during assembly and maintenance.

Transfer Tube Example (Designed by KEK Cryogenic Science Center)

Conventional TRT

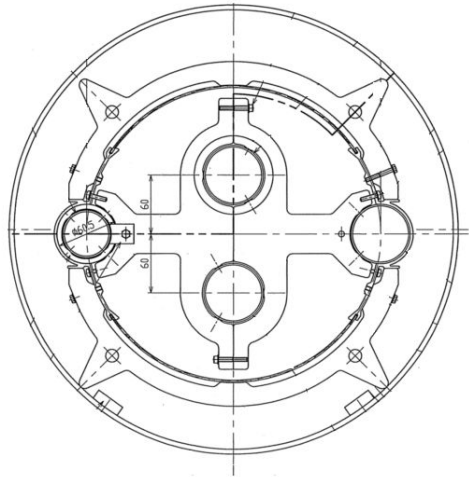

Cross section of TRT @ JPARC
(for supercritical helium)

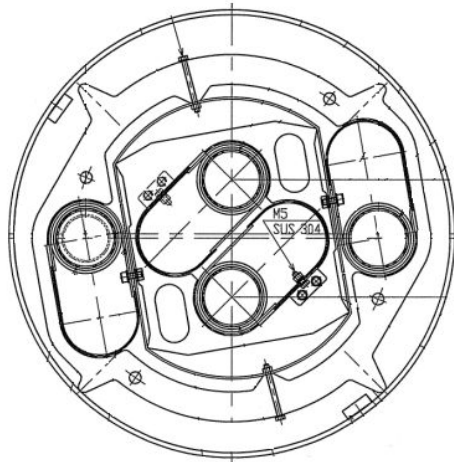

Flexible type TRT

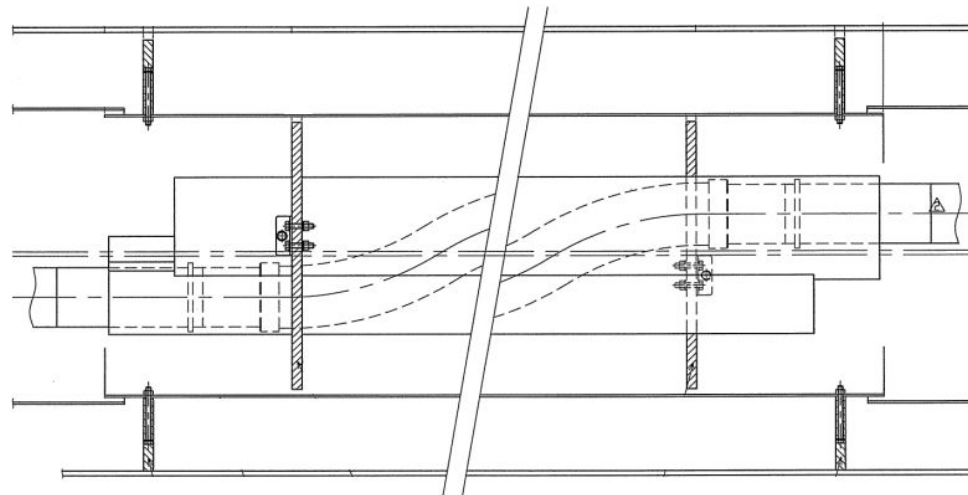

Front and side view of compensation structure of thermal shrinkage.

Designed by N. Kimura, T. Okamura, T. Ogitsu

Summary

- We propose two different cooling schemes (Plan-A and Plan-B).
- Cryogenic configuration of IR in the Japanese mountain site is Plan B.

The reason why Plan B is chosen is described as follows.

- Flexible type TRT has a lot of disadvantage points (Space, installation, cost, etc...)
- It is difficult to optimize performance for example power saving operation in the case of Plan-A.
- From the view point of cryogenics and operation, Plan-B is more conventional and simple cooling scheme and it has higher degree of freedom with respect to operation depending on the situation.

Homework for Cryogenics in the Japanese Mountain Site

- We have to estimate the actual heat load of superconducting equipment.
- Laid down method of Helium gas line and quench recovery line for detectors have to be determined to compensate the push-pull operation.
- Modal analysis including QD0, detector, cryogenic instruments and vibration of platform in order to find a best way to support the QD0 by combination of high vibration reduction material.
- Helium gas storage method in the Japanese mountain site
- The location of the common compressor cavern for detectors and dumping ring from the view point of utilities especially cooling water in the Japanese mountain site. This is strongly dependent on the site.
- Utilities such as cogenerator etc. for emergency.

Appendix

Flexible Type TRT Examples for Push-pull operation

Detector	Specification	Status
CMS	30m long rigid cryo transfer line,	Not applicable to push-pull.
Atlas Endcap Toroids	<ul style="list-style-type: none">• LHe lines diameter = 58mm• Outer shielding = 110mm• Vacuum envelope = 143mm• Bending radius = 2 m (see next page)	Flexible cryolines have been successfully activated.
SiD	SiD foresees a flexible cryoline $\Phi 160\text{mm}$. Bending radius 2.0m?	Under design?
CLIC	Bending radius 1.5 m~ 2.0m (see P20)	Under design?

Section through flexible TRT for ATLAS Endcap Toroids

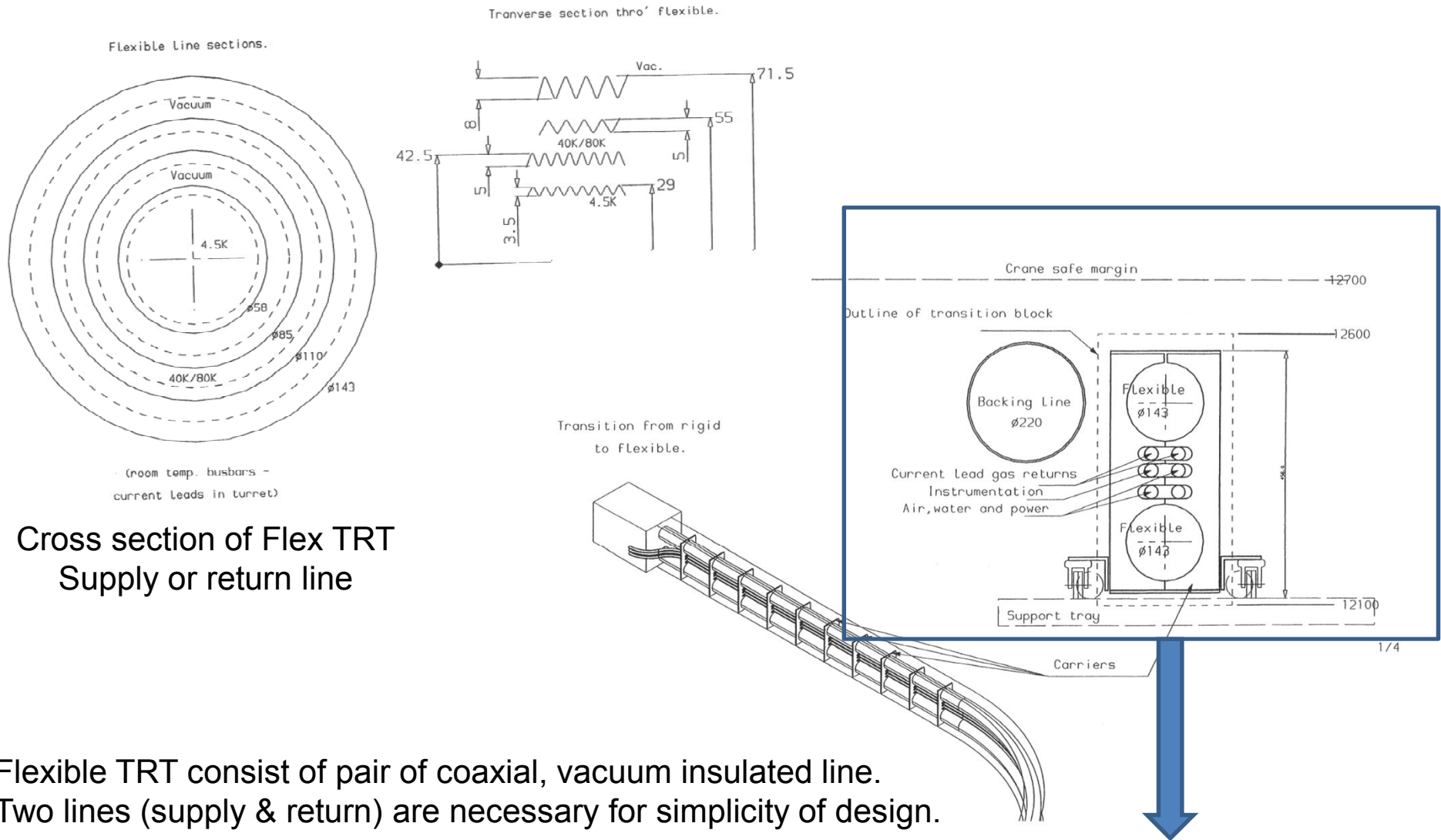

Cross section of Flex TRT
Supply or return line

Flexible TRT consist of pair of coaxial, vacuum insulated line.
Two lines (supply & return) are necessary for simplicity of design.

TRT with 2m in bending radius is applicable by dividing supply and return lines independently.¹⁹

Push-pull scenario example using Flexible TRT for CLIC

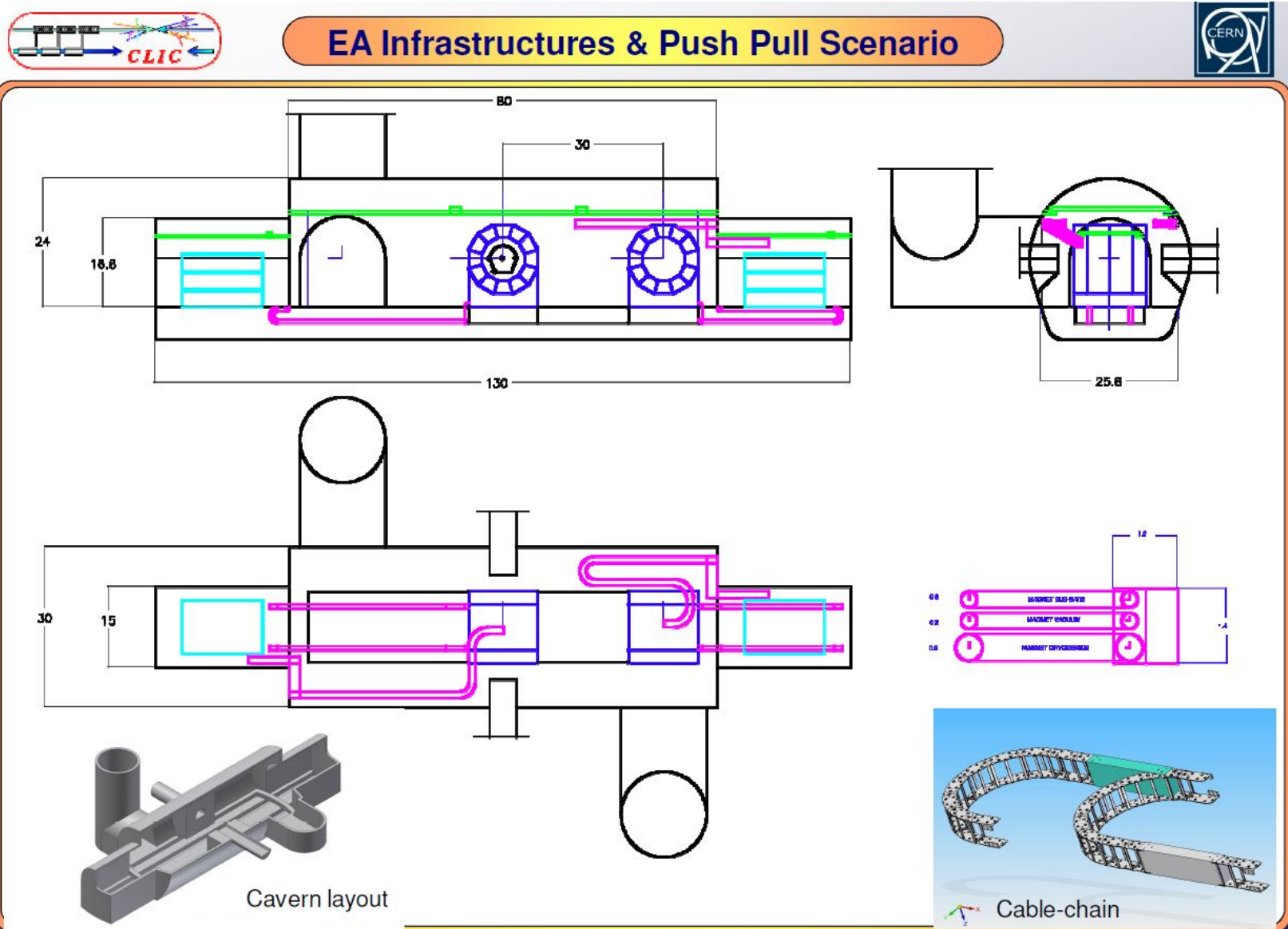

Vibration Adsorption Example

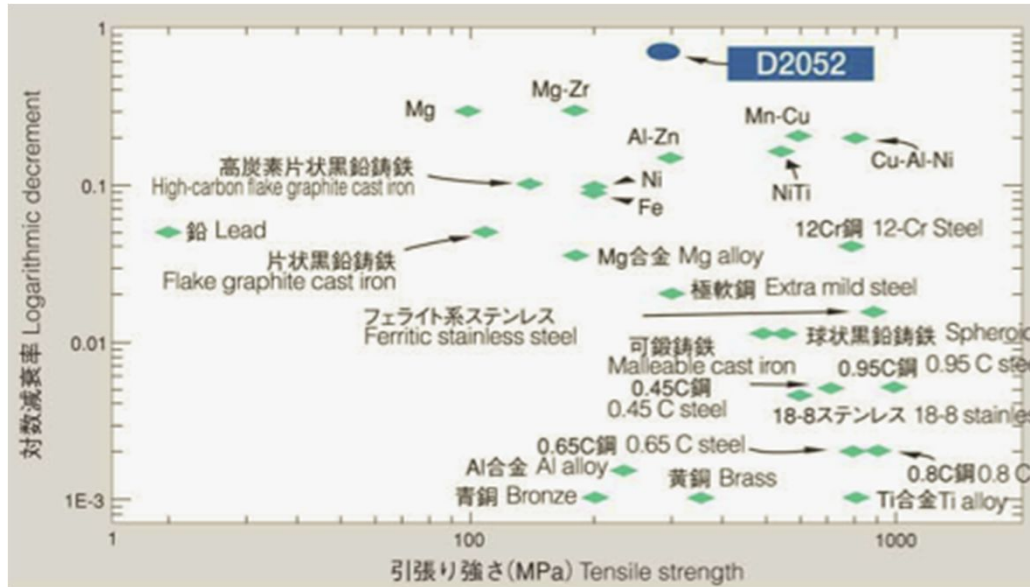

Vibration adsorber



Several vibration absorption boards are installed between top and bottom of the stainless steel boards.

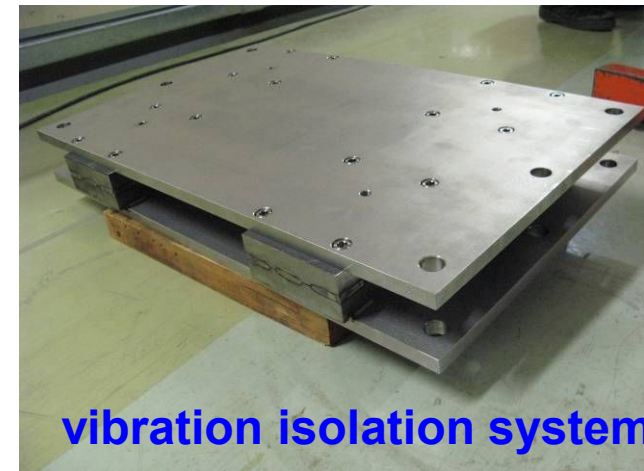
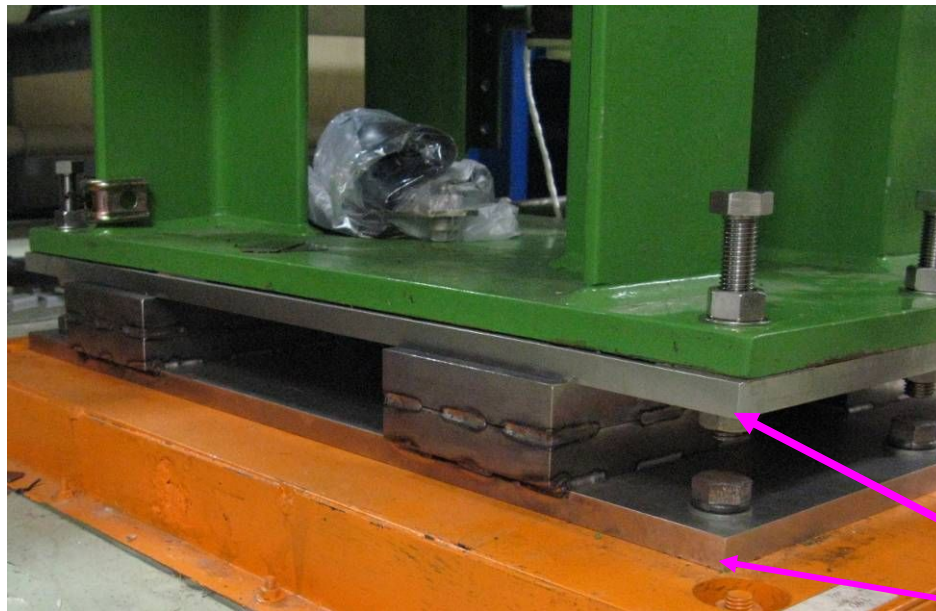

Stainless Steel Base

vibration isolation system

Modal Analysis Example

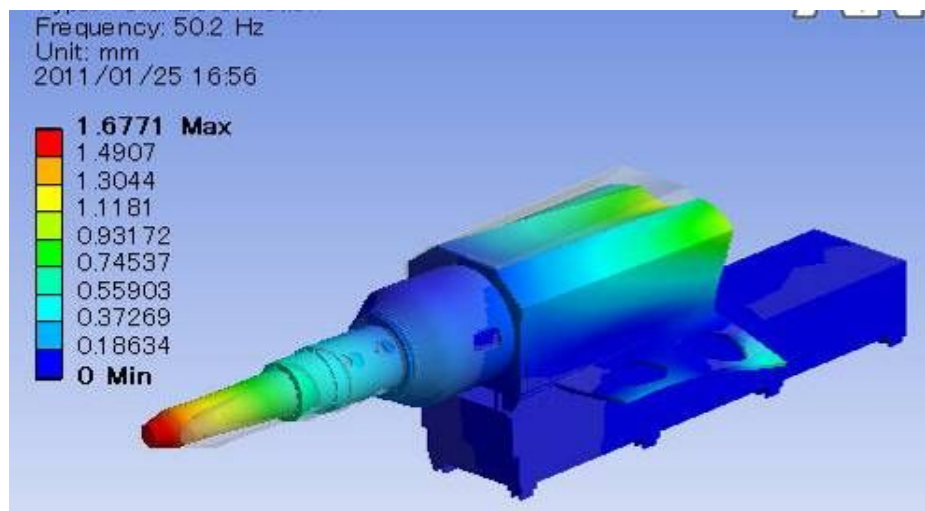
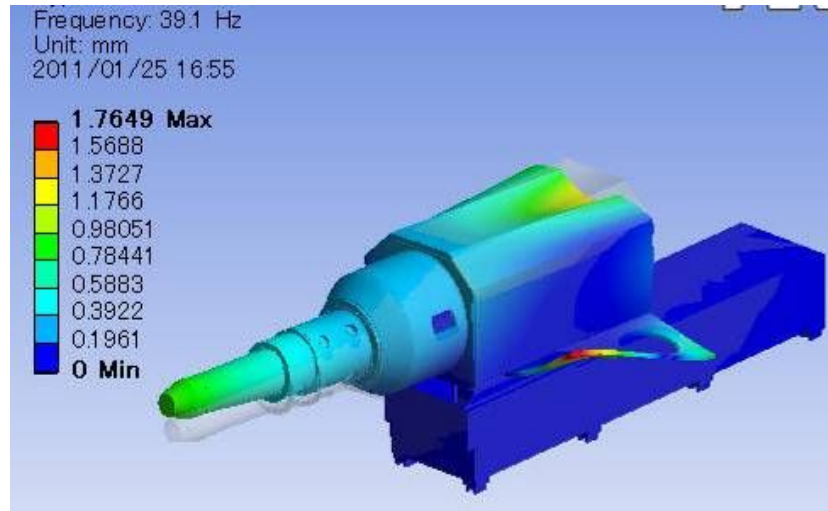
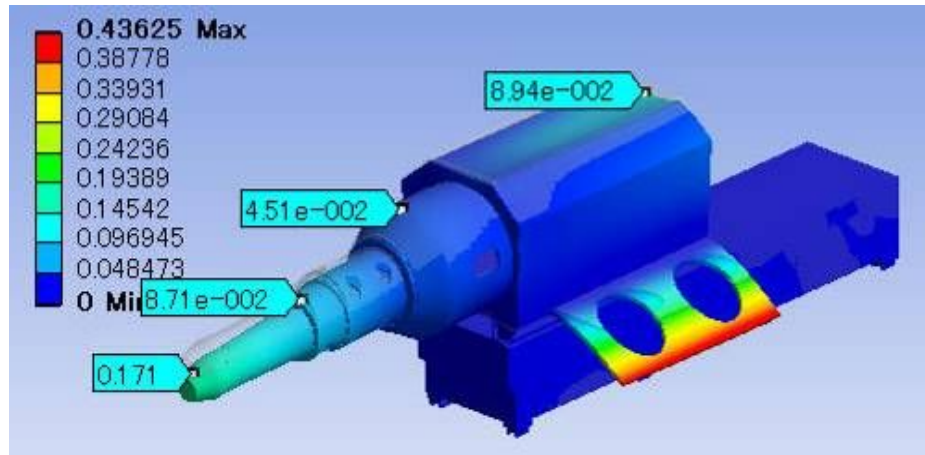
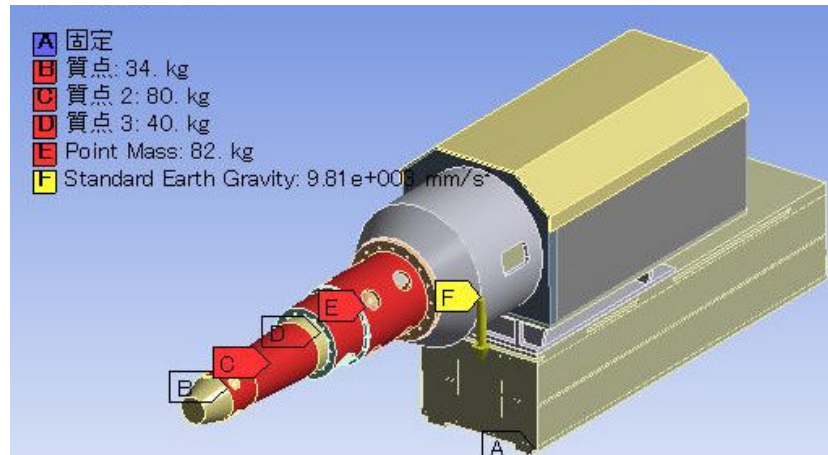

Instrument Example to measure the vibration Performed by H. Yamaoka

In order to measure vibration for three orthogonal directions.

Three laser displacement meters, LV-9300A

(range, 100 micrometers; resolution, 3 nm; frequency range, DC-100 kHz),

Size and Spec of Cold Box for Each Plan

- Plan A :

- Cooling capacity \sim 10 kW
- Size \sim Diameter=3m, Length=10m, Height=4m

- Plan B :

- CB for SiD+QD0, 2.0 kW @4.2 K
- CB for ILD+QD0, 2.0 kW @4.2 K
- CB for QF1, Crab cavity, 2.0 kW @4.2 K
- Size \sim Diameter=2m, Length=6.7m, Height=3m

Cooling capacity difference between each plan mainly depends on the influences of cryogenic instruments such as TRT, distribution box etc .

Plan-A: Schematic Flow Diagram

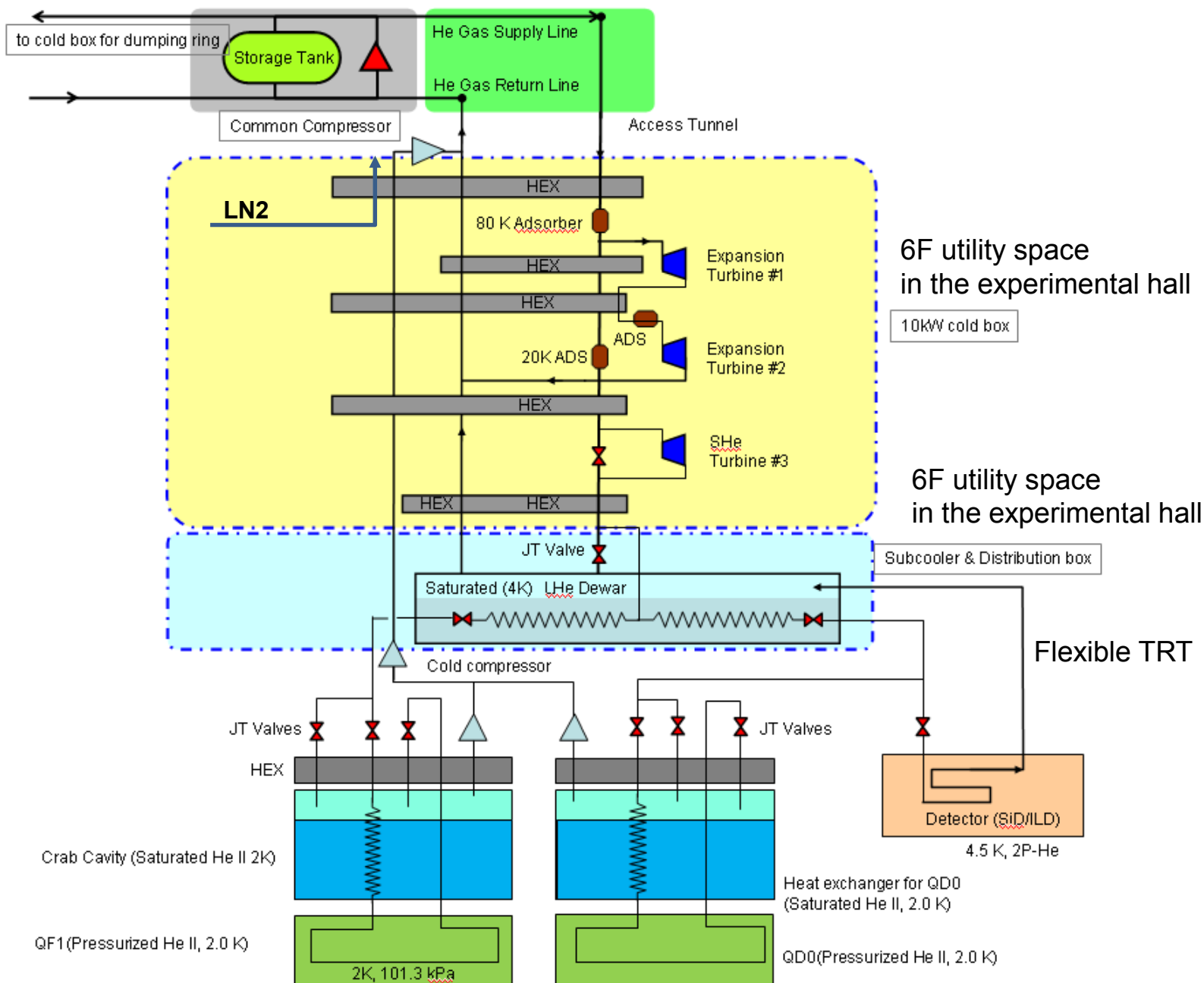

Plan-B: Schematic Flow Diagram for SiD/ILD,+QD0

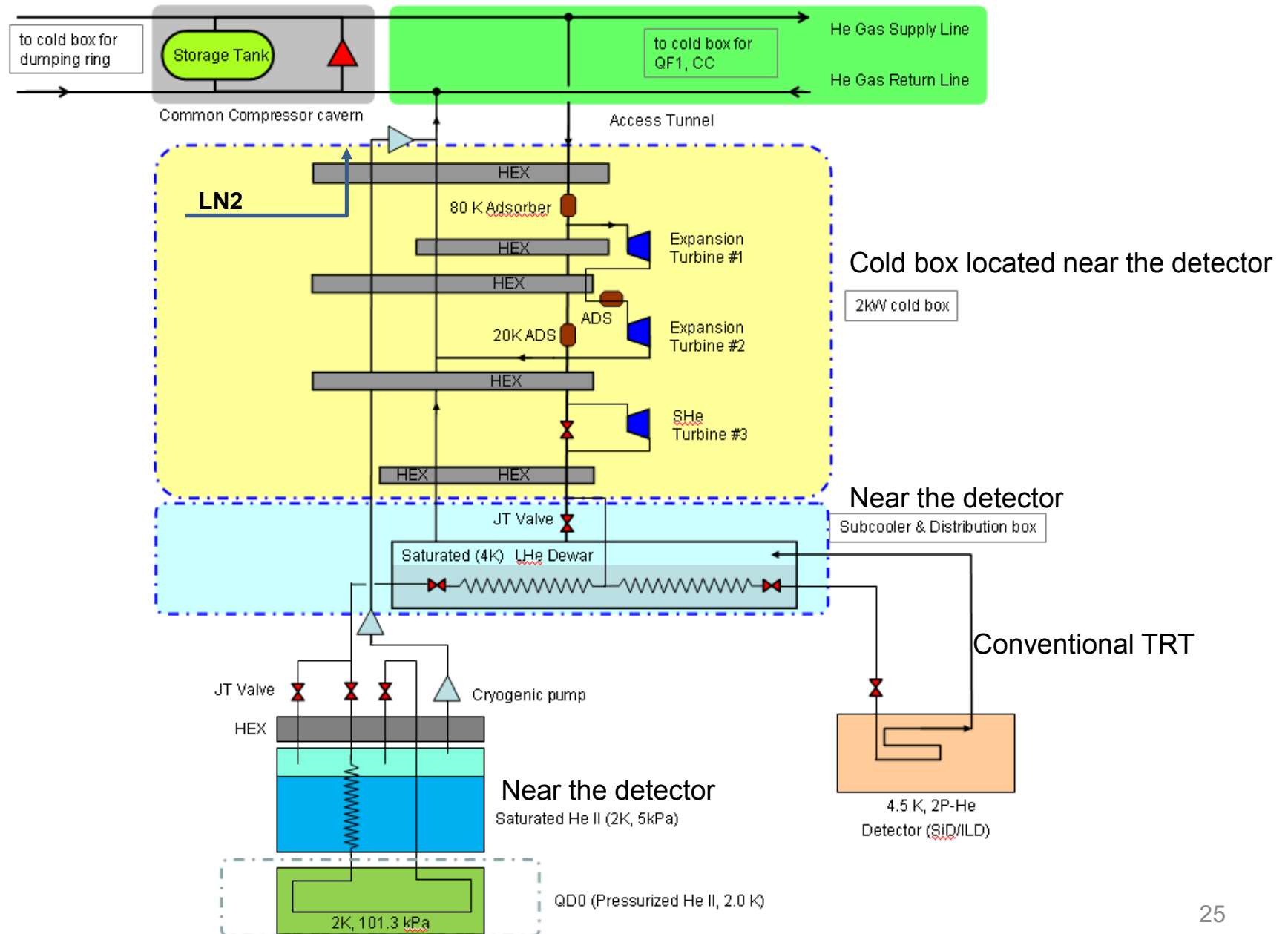

Plan-B: Schematic Flow Diagram for CC and QF1

