

The ILD DBD

Frank Simon
MPI for Physics & Excellence Cluster 'Universe'
Munich, Germany

LCWS 2012, Arlington, TX, USA, October 2012



Outline

- The ILD Concept
 - Overview
 - Subsystems
- The ILD Detector System
- Software & Performance
- Summary

From the LOI to the DBD

The ILD Concept

ILD - Overall Design

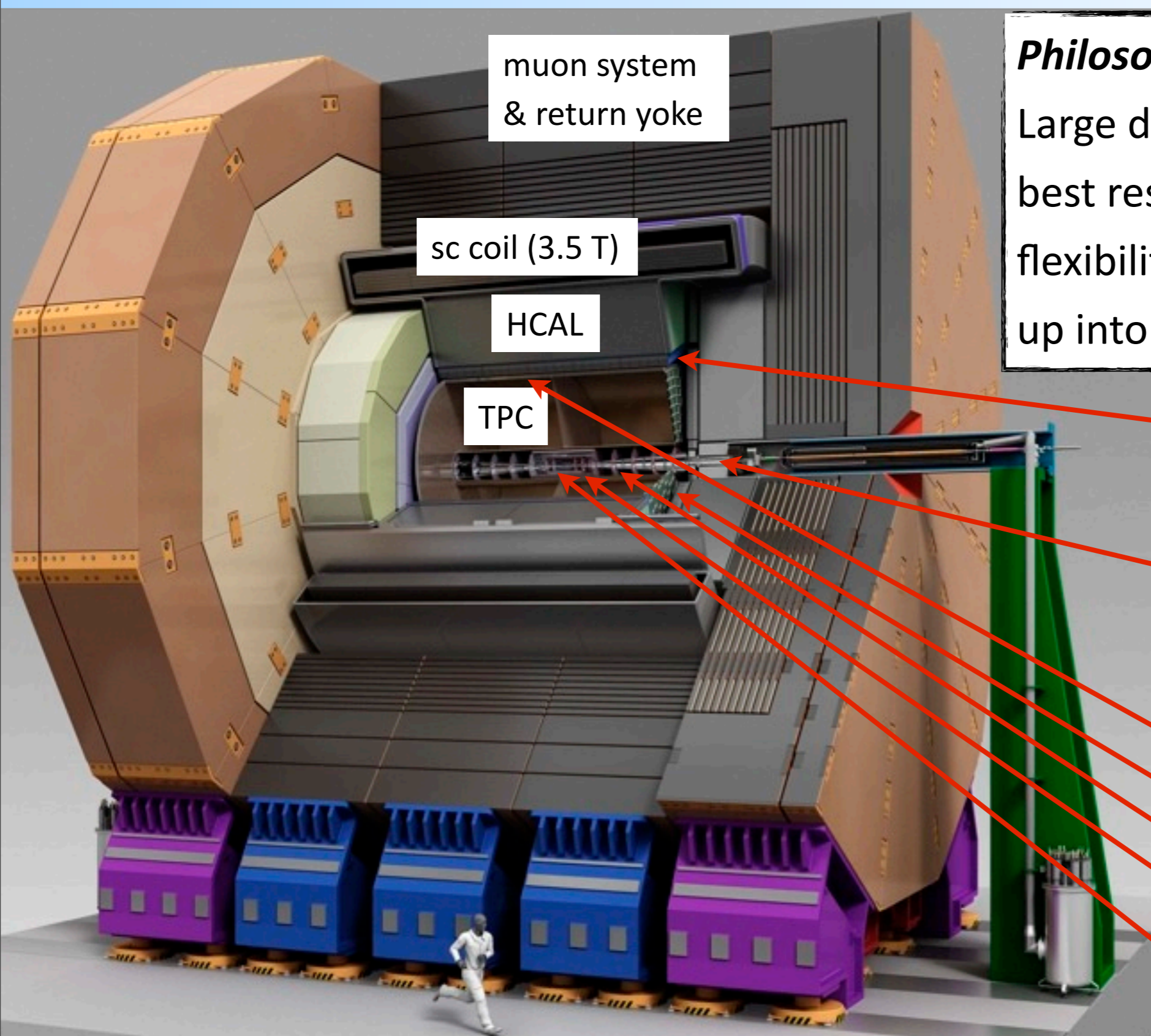

muon system
& return yoke

sc coil (3.5 T)

HCAL

TPC

Philosophy:
Large detector optimized for best resolution, providing flexibility for higher energies up into the TeV range

- ECAL
- forward calorimeters*
- LumiCAL
- BeamCAL, LHCAL
- silicon tracking*
- Silicon External Tracker
- Endplate Tracking Detector
- Forward Tracking Disks
- Silicon Inner Tracker
- VerTeX Detector

ILD Design - General Considerations & Challenges

- Performance goals set by physics
 - Jet energy resolution < 3% - 4% over full relevant energy range
 - Track momentum resolution $\delta(1/p_T) \simeq 2 \times 10^{-5} / \text{GeV}/c$
 - Excellent vertexing for b & c identification
- Resulting main requirements and challenges
 - Highly granular PFA calorimeters
 - Low material budget in front of calorimeter
 - Power-pulsing, low power consumption
 - Triggerless readout
 - Highly integrated electronics

Vertex Detector Technologies

- Active development of several technologies, synergies with LHC & others
 - All provide low material budget by thin sensitive layers
 - Trade-off between readout speed and pixel size (no time stamping)
- CMOS pixel sensors
 - $\sim 17\mu\text{m}$ pixel precision layers, $17 \times 85 \mu\text{m}^2$ pixel fast layers to reduce effective occupancy
 - Low material double layer “PLUME” demonstrated
- FinePitch CCDs
 - $\sim 5 \mu\text{m}$ pixels in inner layers, $\sim 10 \mu\text{m}$ pixels further out
 - Small prototype successfully tested, (almost) full size prototype available
- DEPFETs
 - $\sim 20 \mu\text{m}$ pixels, all-silicon modules with integrated support structure

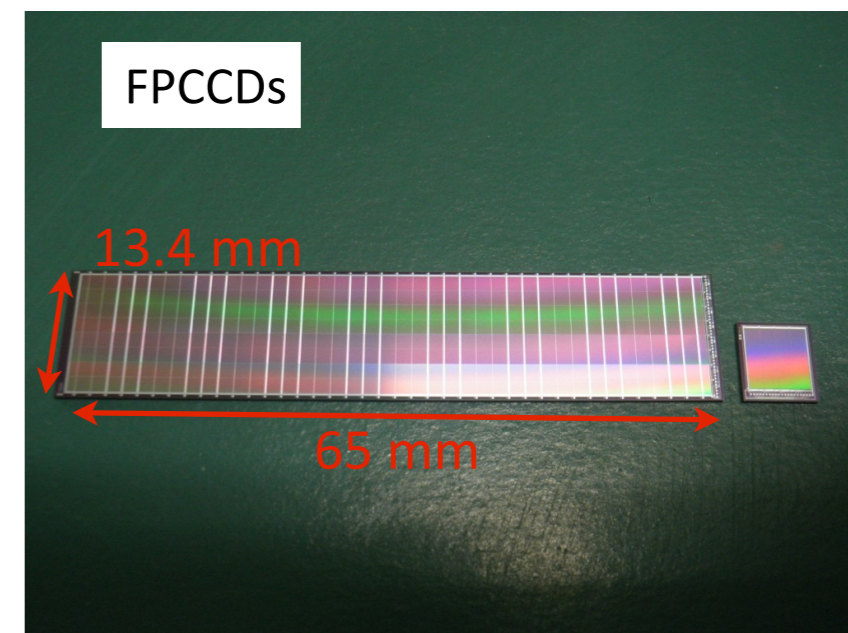

The Main Tracker: TPC

- Main tracker philosophy:
Continuous tracking for excellent pattern recognition and dE/dx capability instead of best possible single point resolution
- The ILD TPC
 - Up to 224 space-points per track
 - Single point resolution $< 100 \mu\text{m}$ in $r\phi$
 - Two-hit separation $\sim 2 \text{ mm}$ in $r\phi$
 - Low material budget: $5\% X_0$ in barrel region, $< \sim 25\% X_0$ in the endcaps
 - Standalone momentum resolution

$$\delta(1/p_T) \simeq 10^{-4} / \text{GeV}/c$$

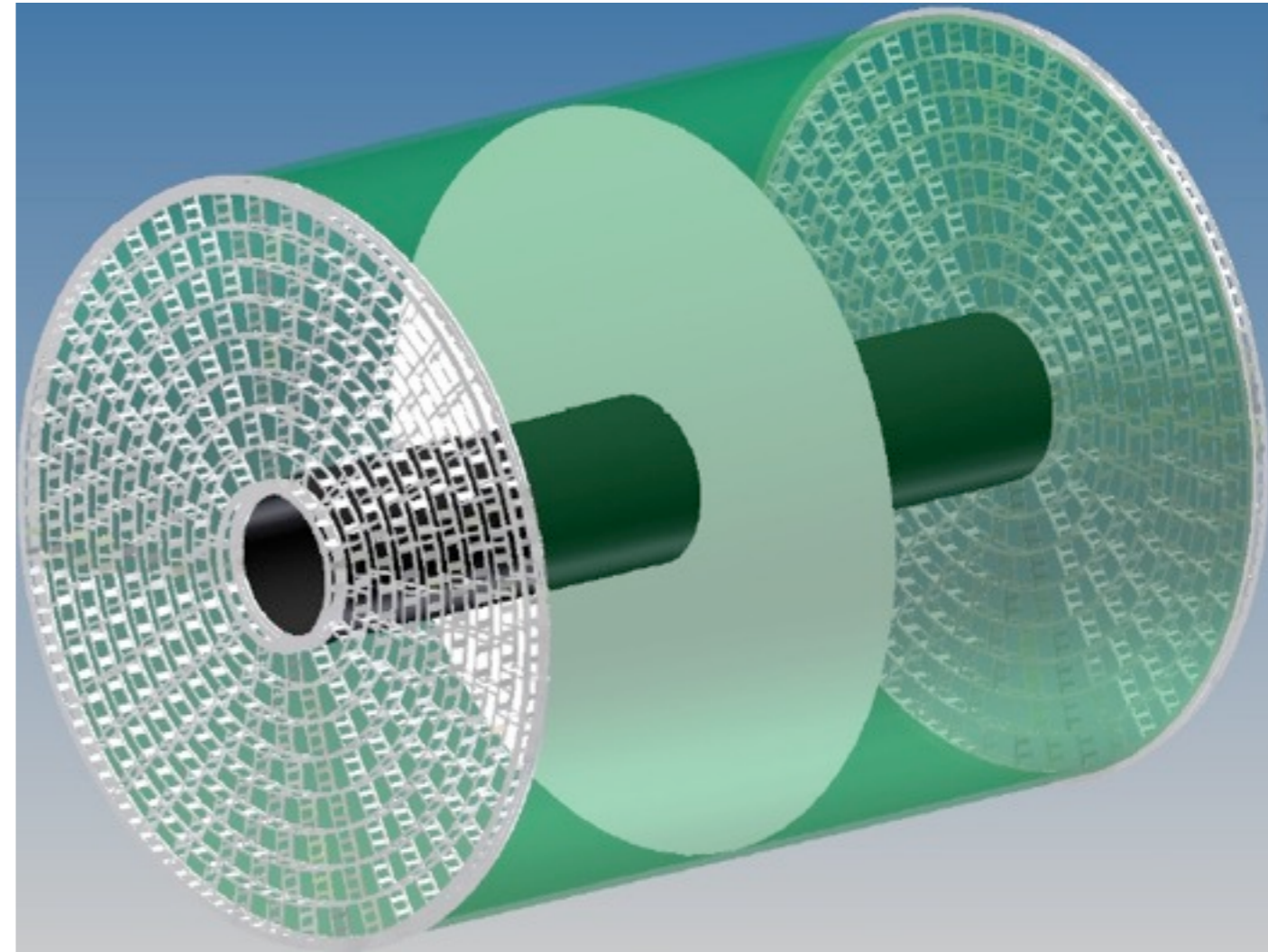

Two main readout options:
GEMs, Micromegas
Alternative: pixel detectors

TPC Development

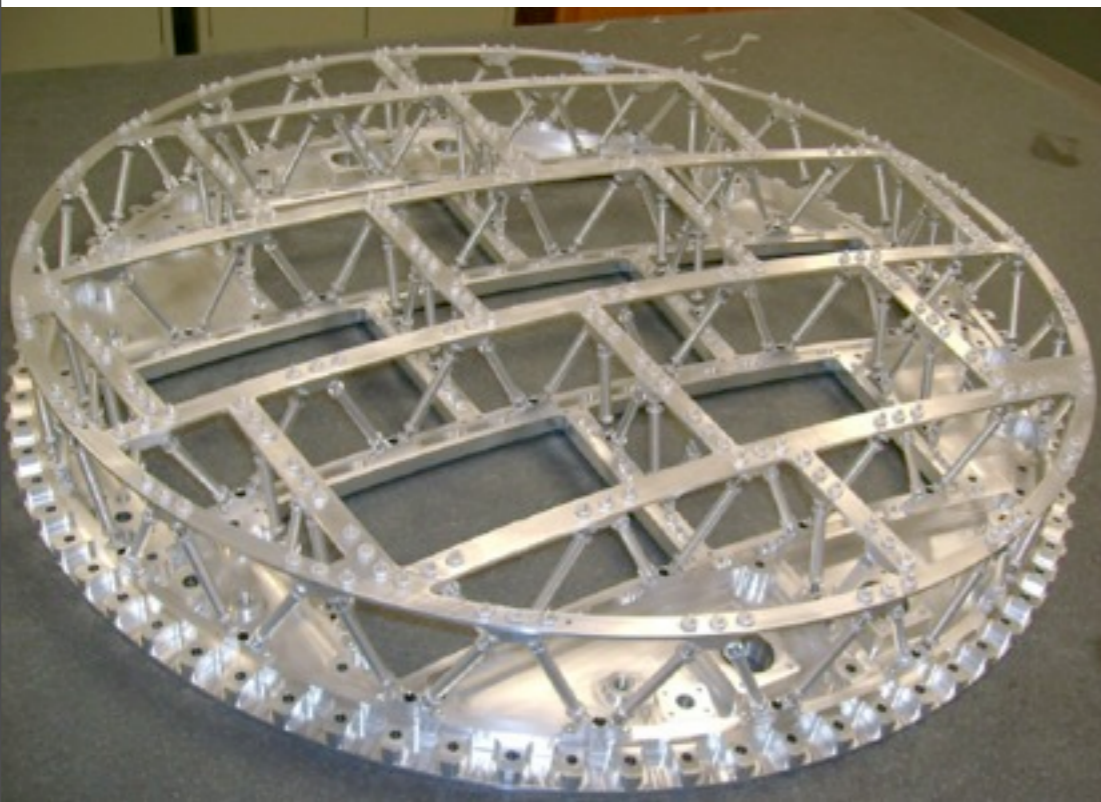

- Large prototype with “space frame” endplate
- Test in magnetic field up to 4 T
- Two readout technologies already tested:
Triple-GEM, Micromegas

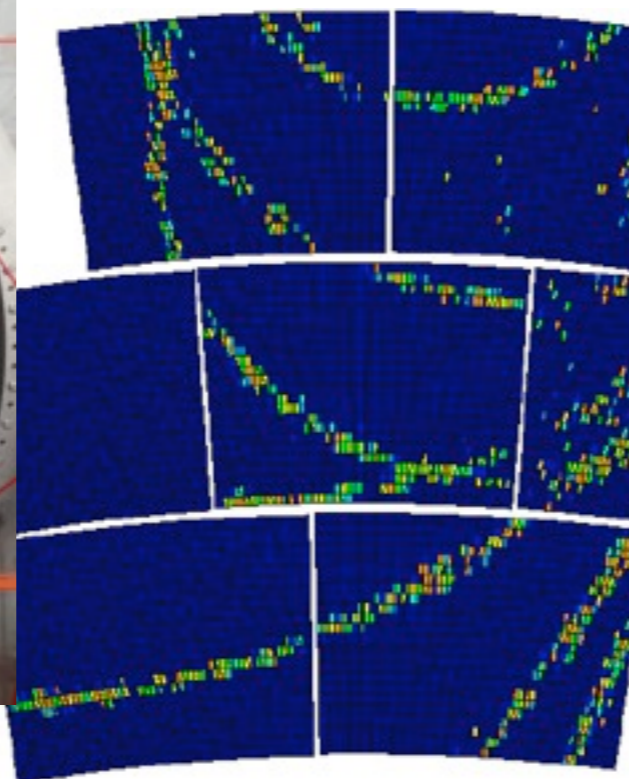
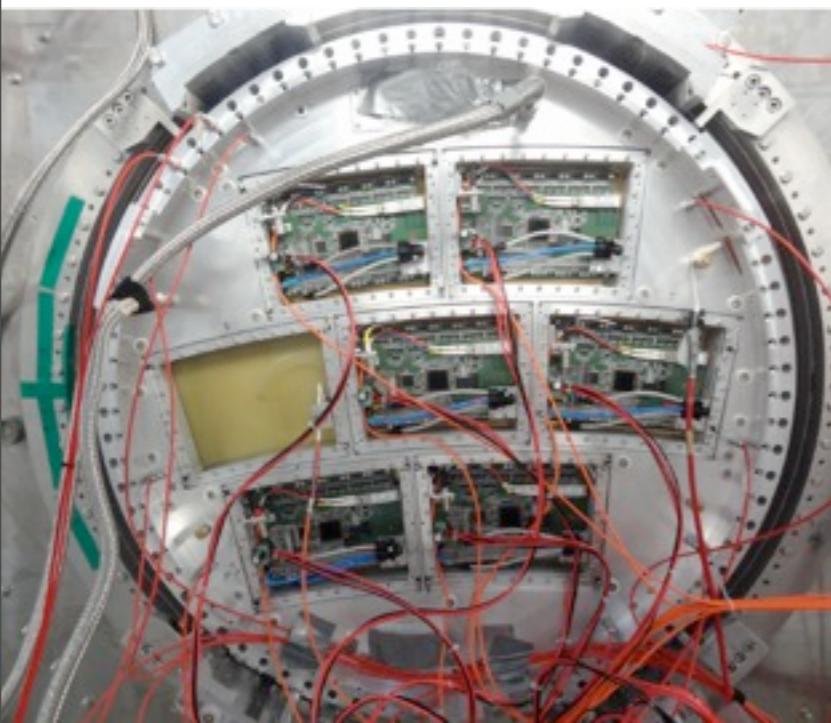

smaller prototype, high B-Field

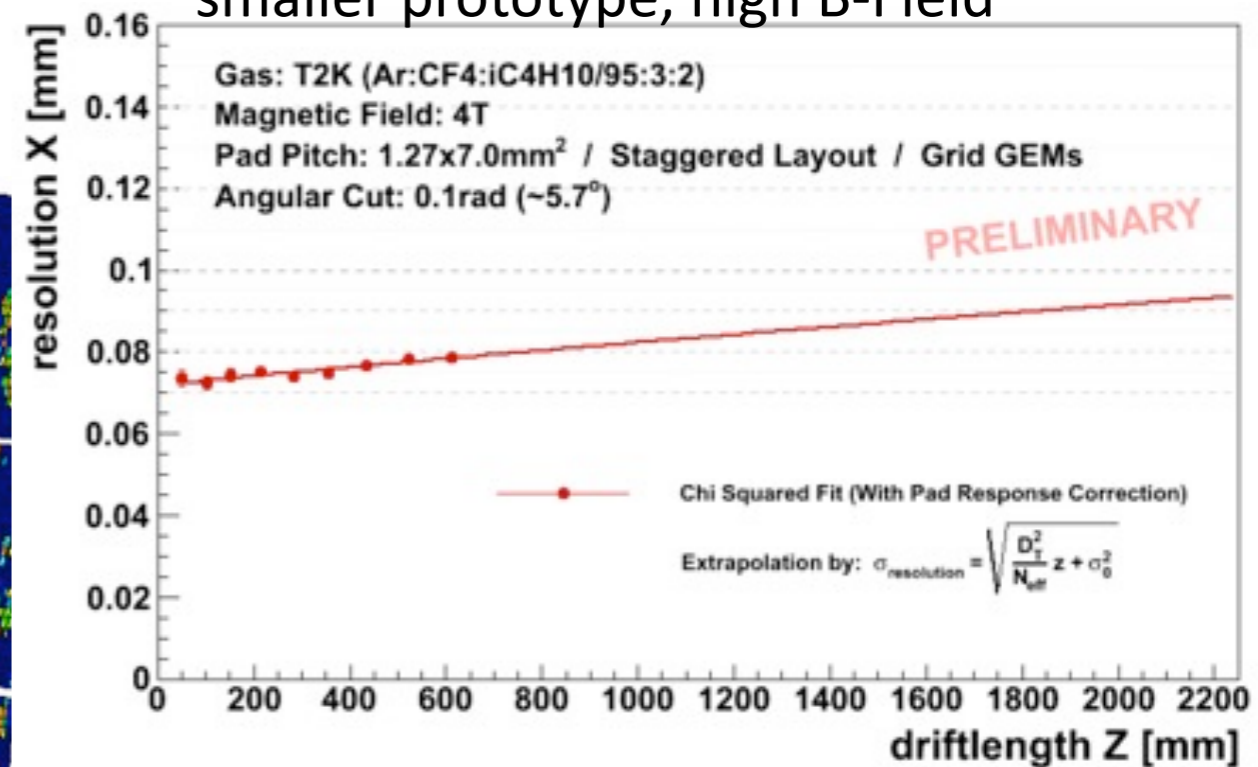

extrapolated resolution < 100 μm
also beyond 2000 mm!

The Silicon Trackers

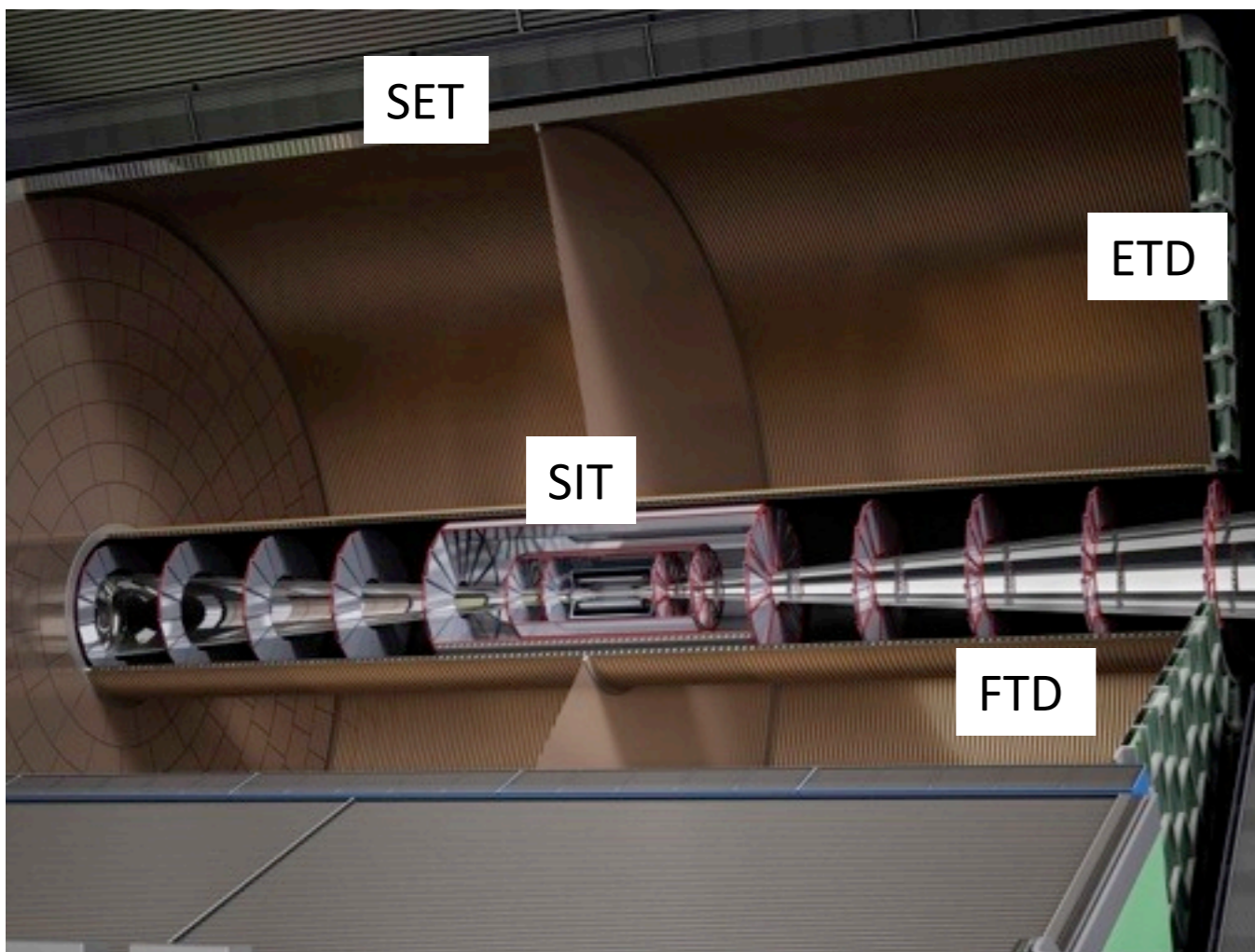

- Silicon tracking to complement the TPC main tracker:
 - Improved resolution
 - Time-stamping
 - Calibration of distortions & alignment
 - Extended coverage in the forward region
- Combined tracker resolution:
$$\delta(1/p_T) \simeq 2 \times 10^{-5} / \text{GeV}/c$$

- Inner tracking barrel SIT - 2 fake double-sided strip layers, 2 space points
- Outer tracking barrel SET - 1 fake double sided strip layer, 1 space point
- Outer forward tracking layer ETD - 1 fake double sided strip layer, 1 space point
- Inner forward tracker FTD - 7 disks (2 pixel, 5 strip)
- ▶ Common technology & design for all strip sensors in the silicon trackers

Silicon Tracker Technology

- Philosophy: Compact, simple and cost-effective modules
- ▶ Edgeless sensors and integrated pitch adapters developed in synergy with LHC upgrades

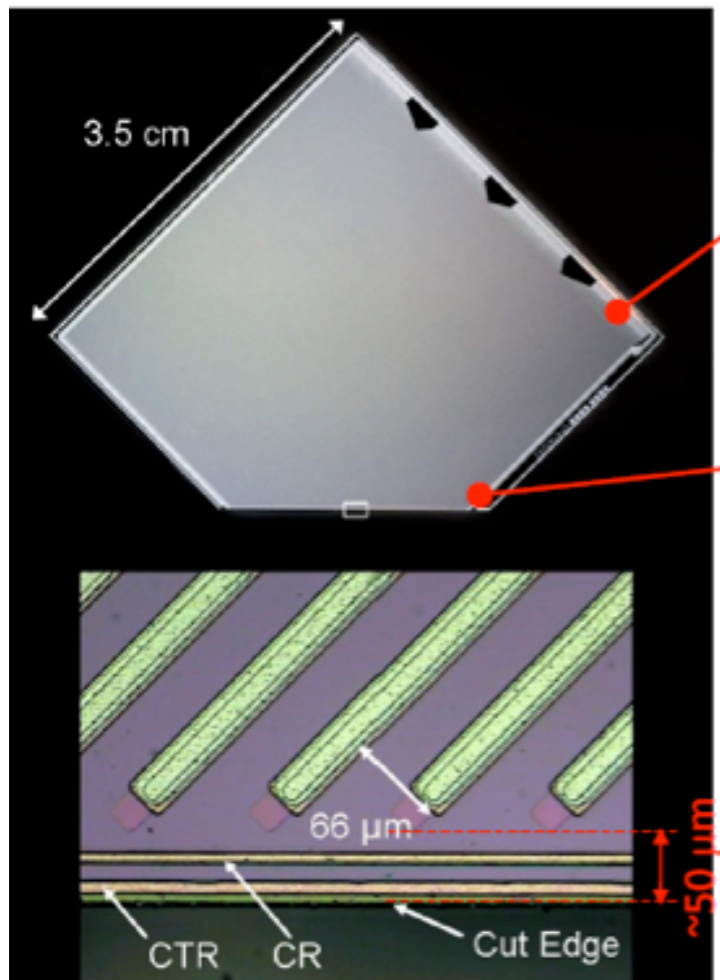

Only 50μm from end of strip to end of sensor!!!

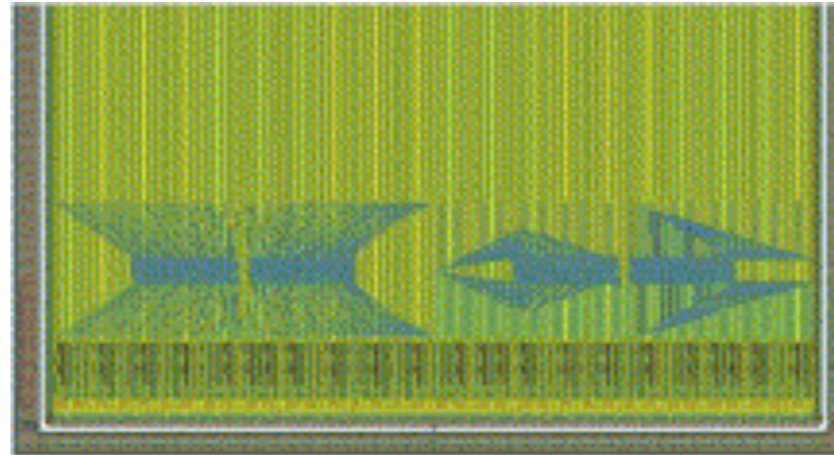

integrated pitch adapter in a second metal layer

Interferometric monitoring of FTD with fiber-optic sensors: Monitor changes of environmental parameters, vibrations, ...

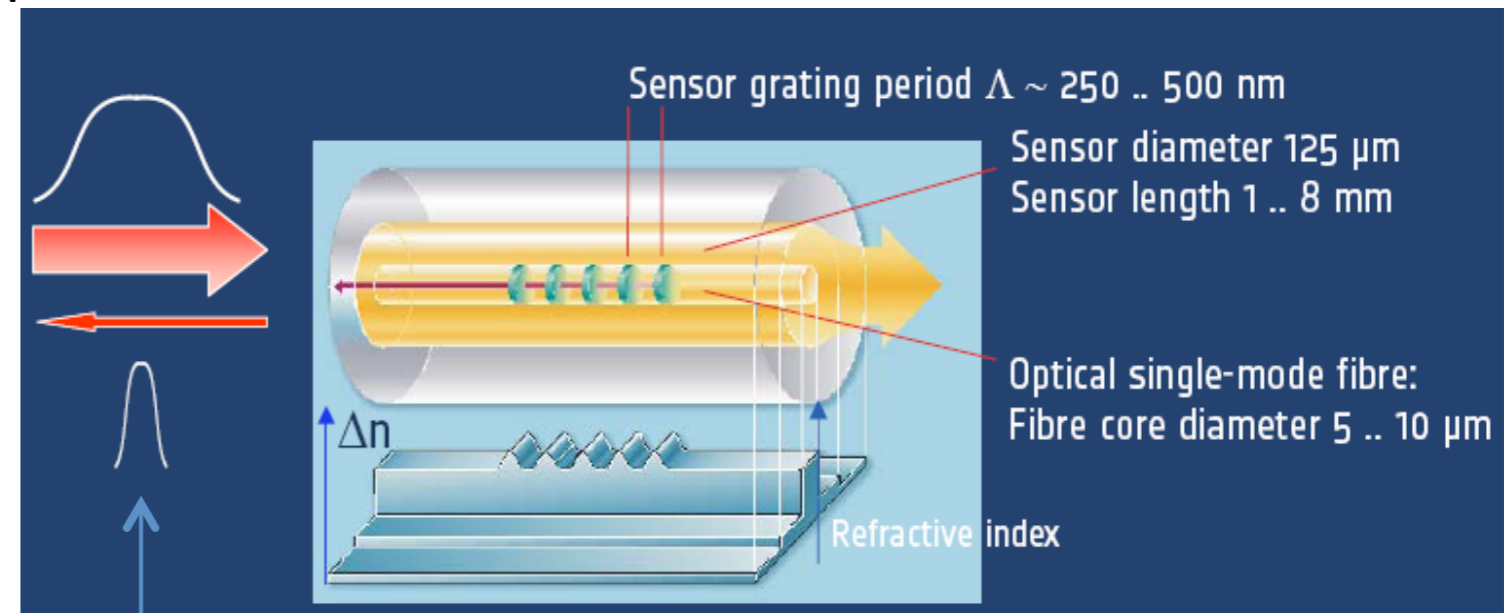

The Main Calorimeters

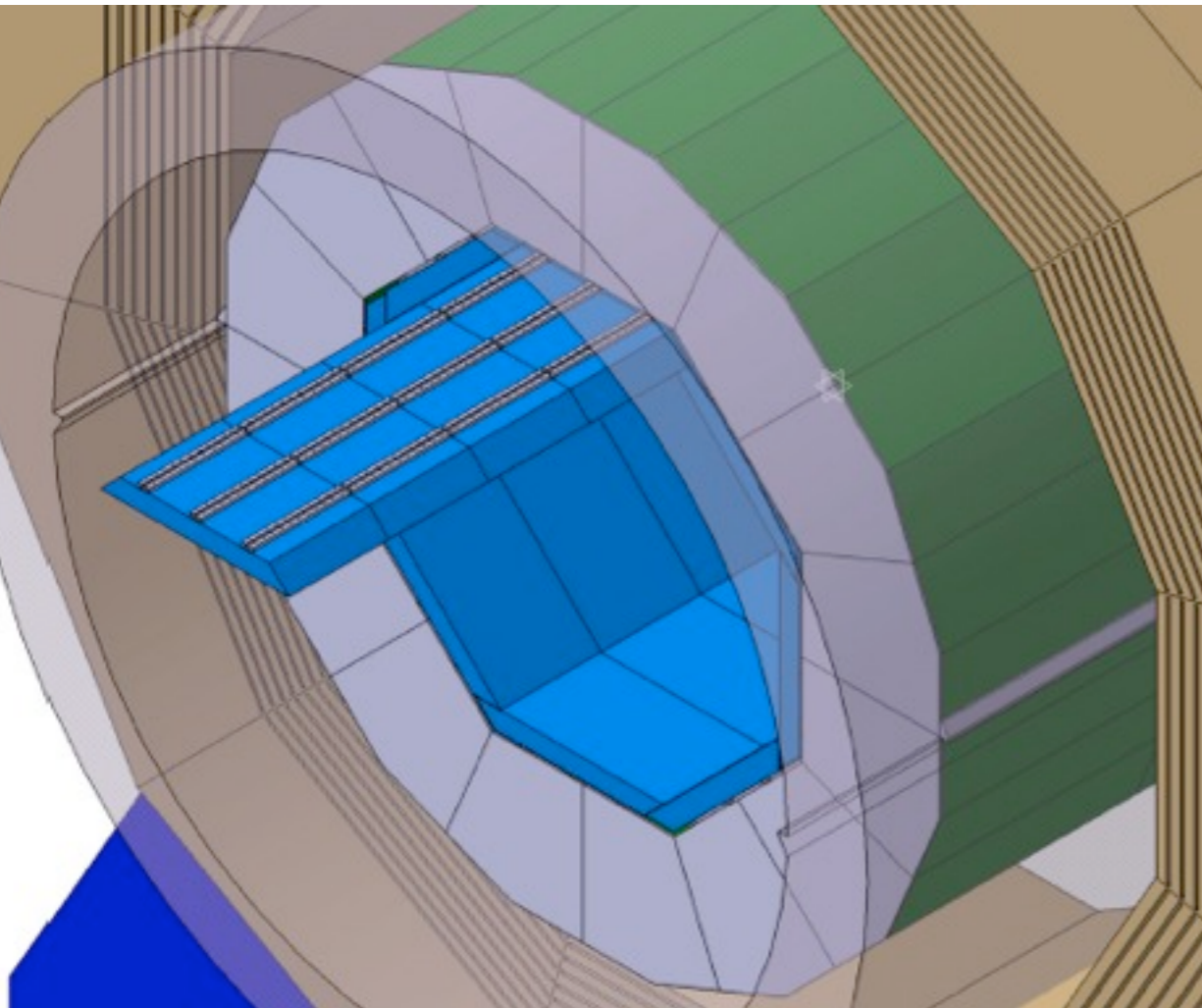

- Main calorimeters optimized for particle flow:
 - High granularity
 - Small Molière radius in ECAL for good particle separation & photon identification
 - Sufficient depth of the HCAL to limit leakage also at 1 TeV
 - Compact design to fit inside magnet
- ECAL with tungsten absorbers and silicon and/or scintillator readout
- HCAL with steel absorbers
 - Analog - Scintillator tiles with SiPMs
 - Semi-digital - Glass RPCs with 2 bit readout, Micromegas as alternative

Calorimeter R&D

- Calorimeter technology for ECAL & HCAL developed by CALICE:
Combined test-beam experiments to demonstrate PFA calorimetry

One highlight:

Shower separation with PandoraPFA in the SiW-ECAL and AHCAL physics prototypes

- ▶ Good agreement with simulations demonstrates realism of our full detector simulations & physics studies

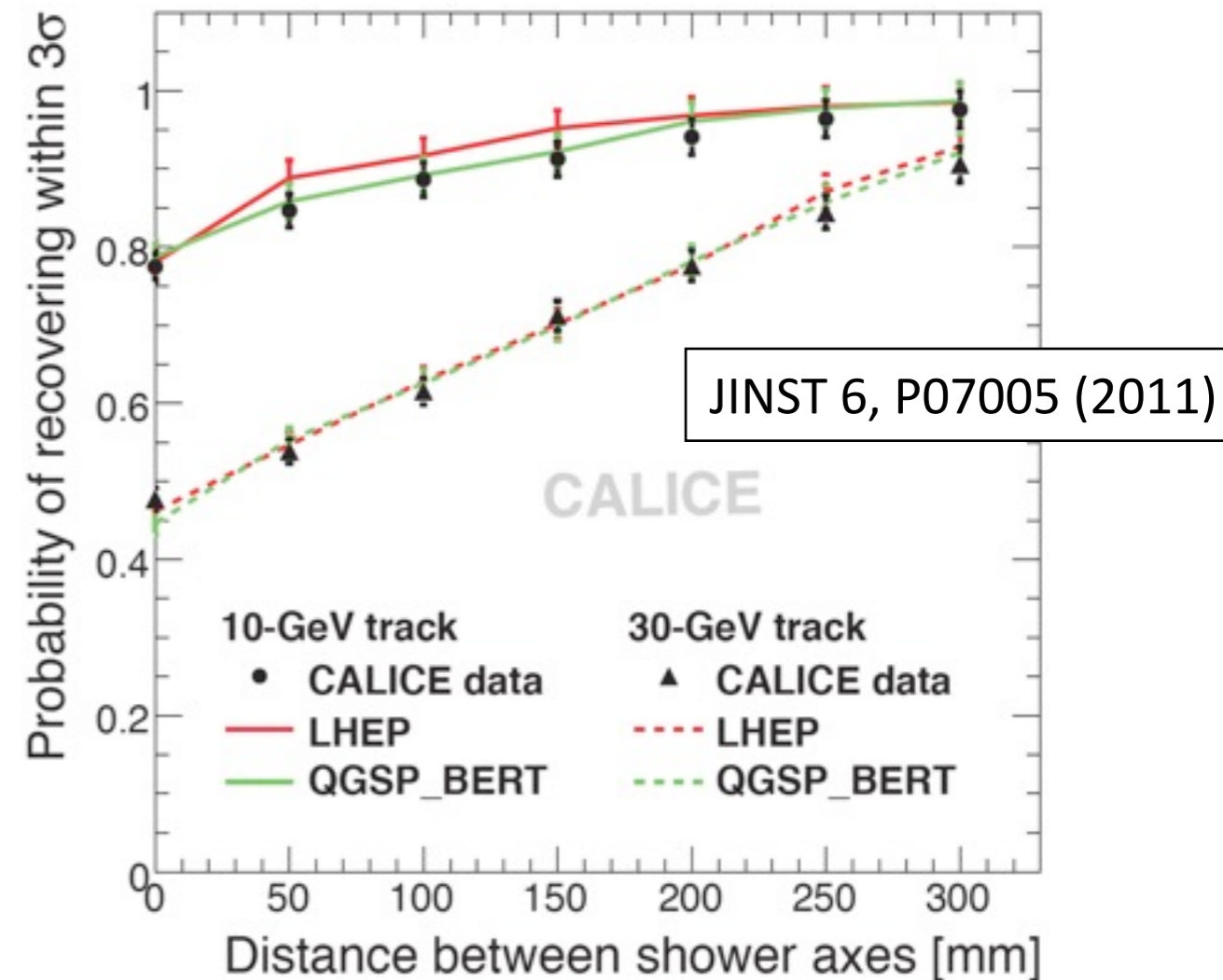

- Readout ASICS for all calorimeter types with a common basis
- Common DAQ system, data format:



The SiW ECAL

- PIN silicon pad readout with $5.5 \times 5.5 \text{ mm}^2$ pads

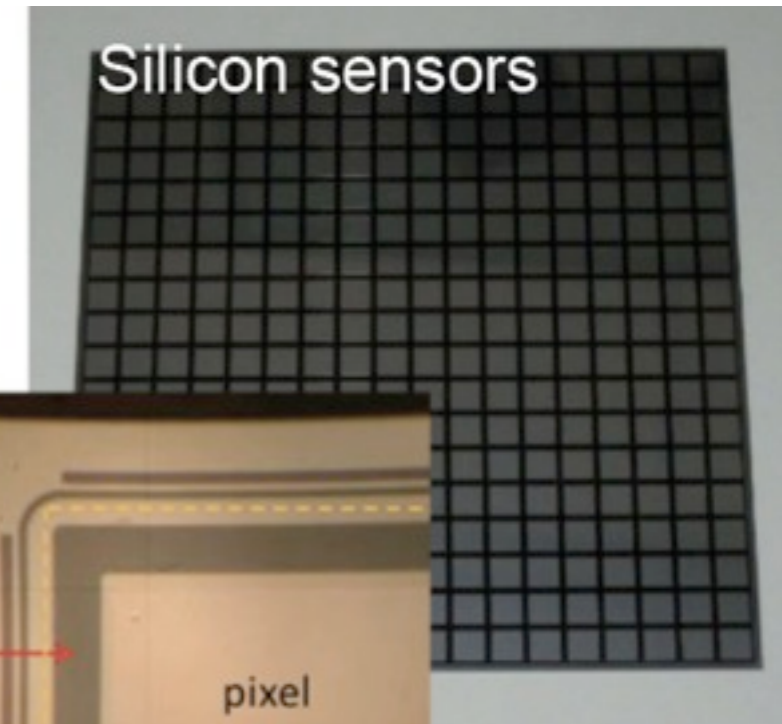
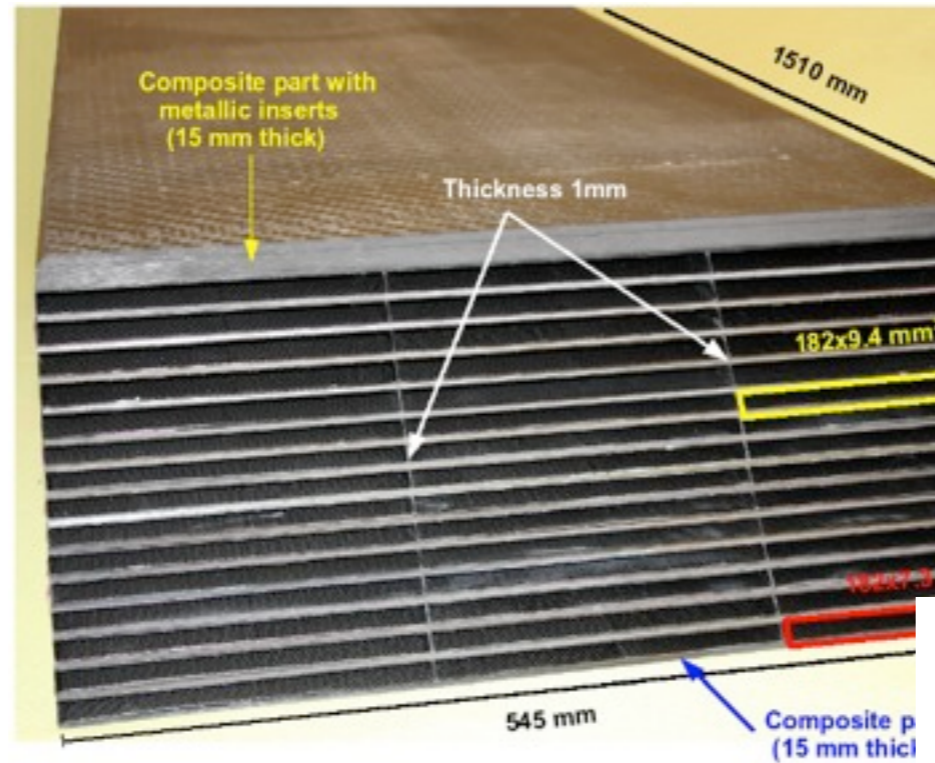
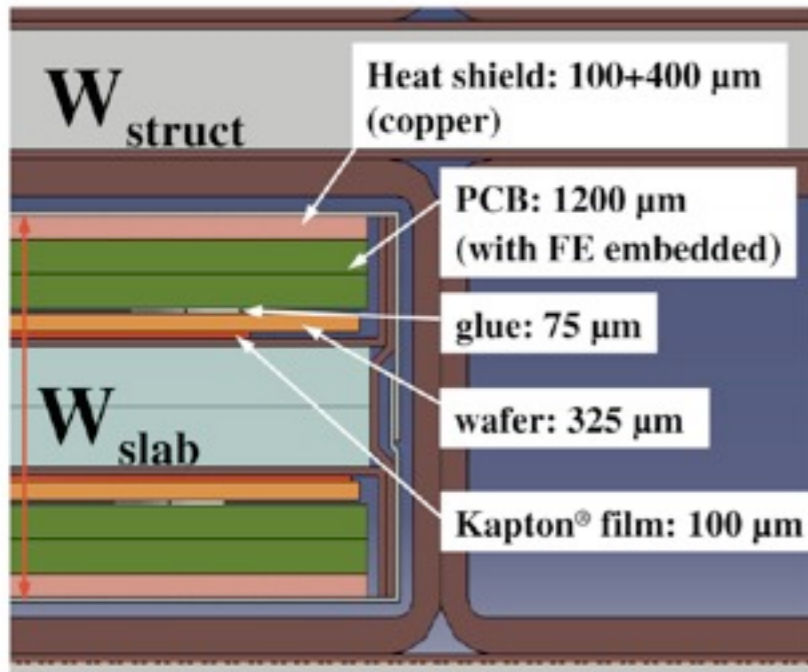

6.8 mm per double layer

Complete tungsten structure for technological prototype exists

Well-established technology: physics prototype in various beam times since 2006

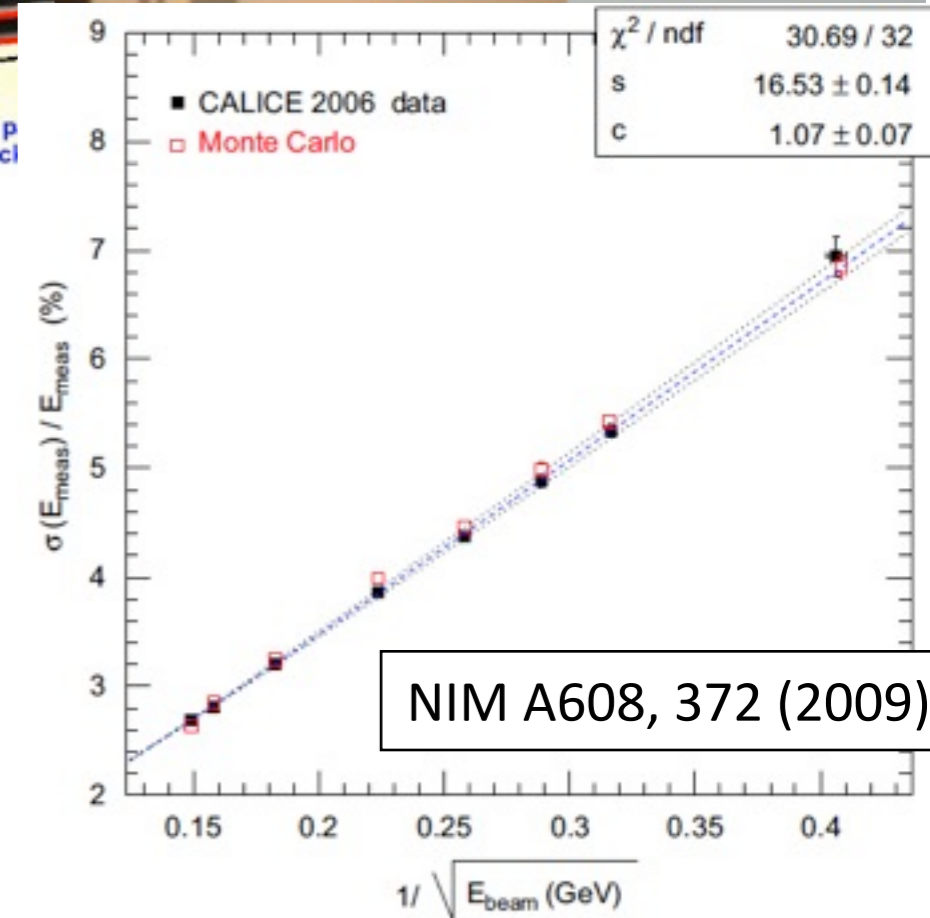

The Scintillator ECAL

- Scintillator strips ($5 \times 45 \times 1 \text{ mm}^3$) read out with SiPMs
 - 6.9 mm per double layer, 0.1 mm more than SiW ECAL
 - Electronics based on AHCAL design - synergies!

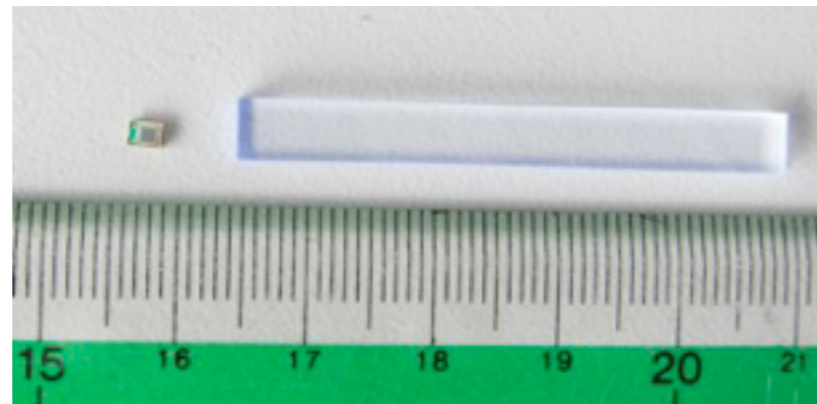

Extensive tests with a physics prototype, first module of technological demonstrator now in test beam at DESY

- Recover $5 \times 5 \text{ mm}^2$ granularity with strip-splitting algorithm
- SiPMs / MPPC with higher smaller pixels under study to increase dynamic range
- Hybrid solutions together with Si layers (interleaved or as two sections) possible

Updated resolution plot?

-> Currently under review in CALICE

The Analog HCAL

- Based on $3 \times 3 \times 0.3 \text{ cm}^3$ scintillator tiles with embedded SiPM

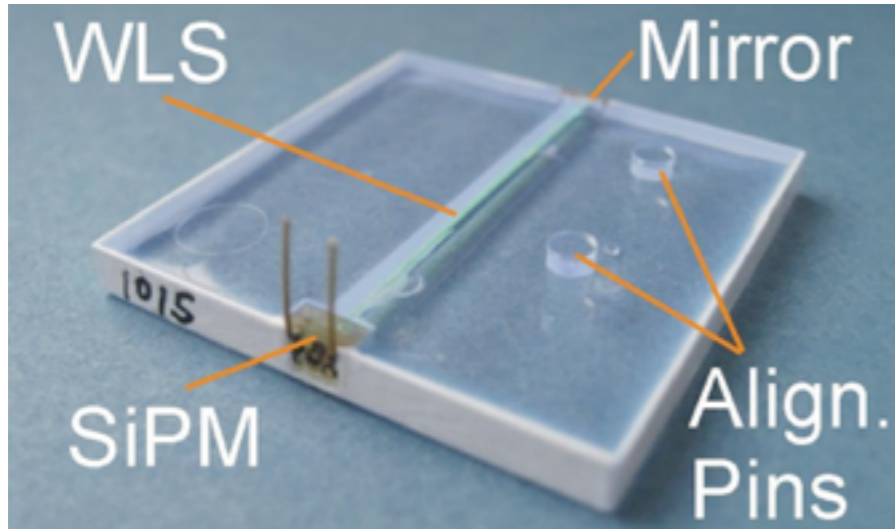

Well-established technology: Extensive tests in beam with a 8 000 channel system since 2006

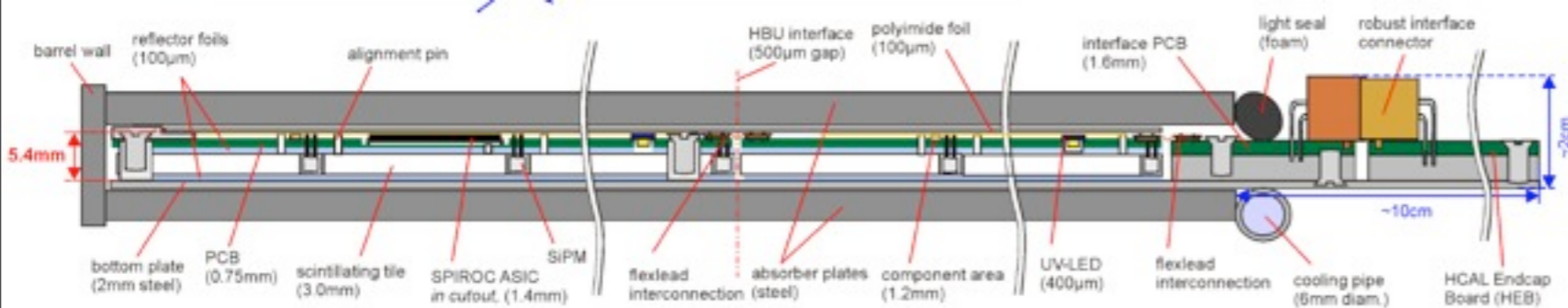

Compact design: $< 6 \text{ mm}$ non-absorber material per layer

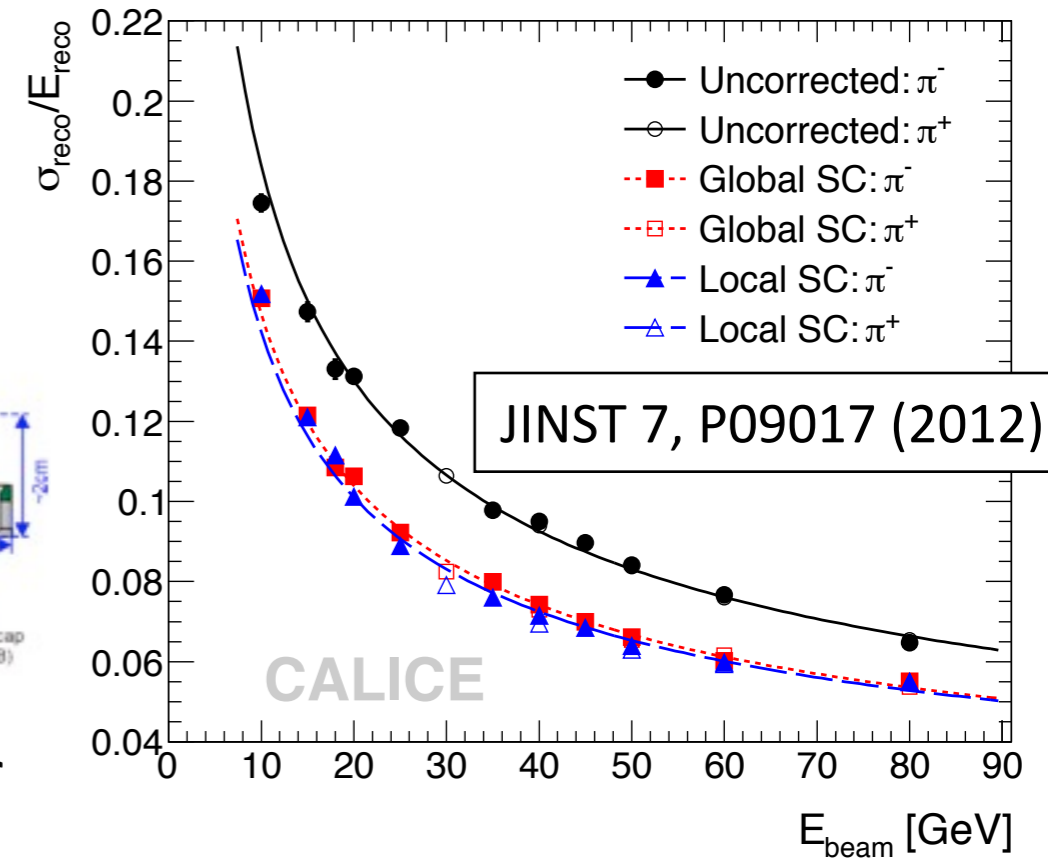

Hadronic energy resolution of physics prototype with software compensation:
 $45\%/\sqrt{E} \oplus 1.8\%$

The Analog HCAL

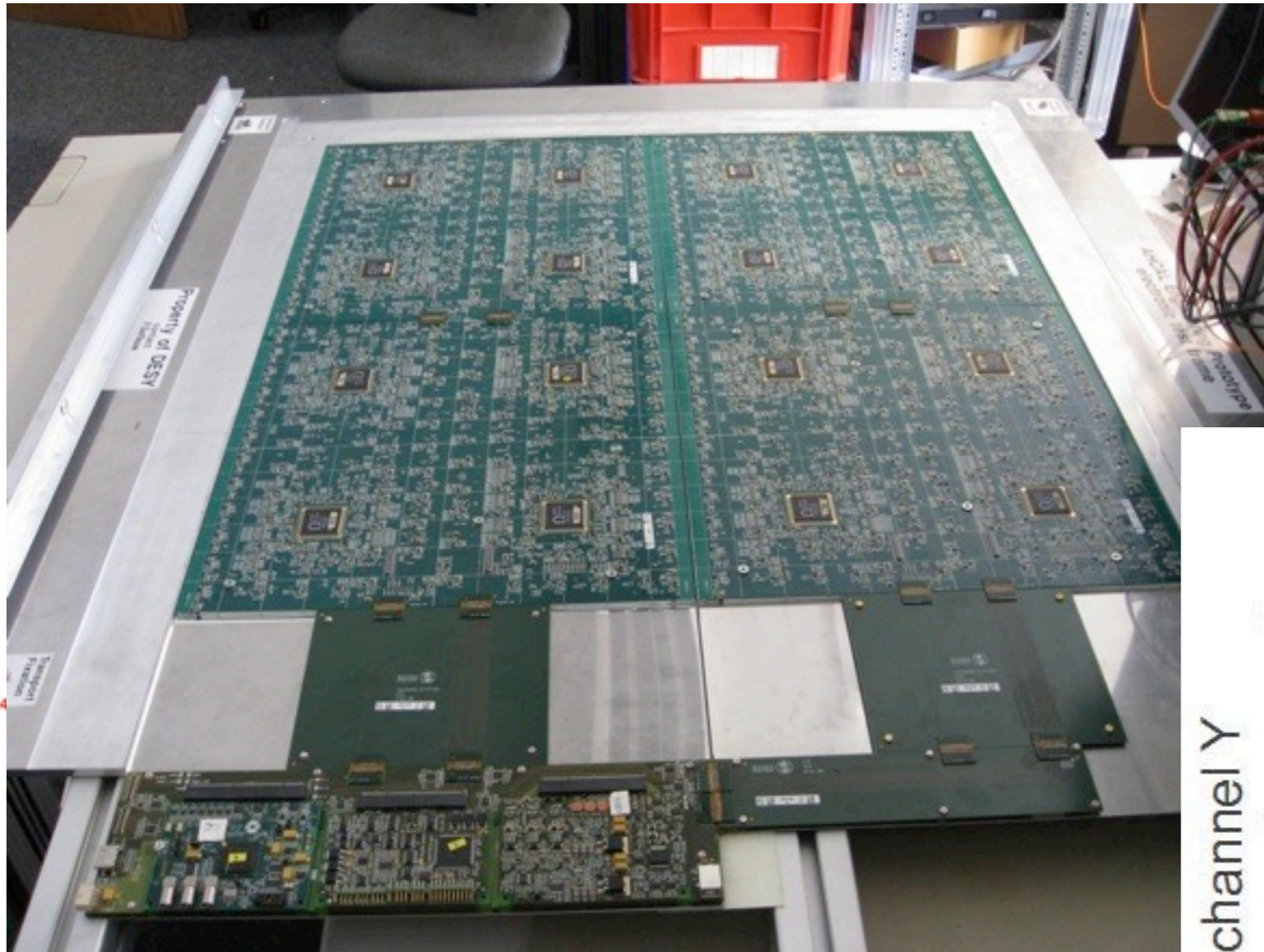

Embedded SiPM

technology: Extensive tests in beam
channel system since 2006

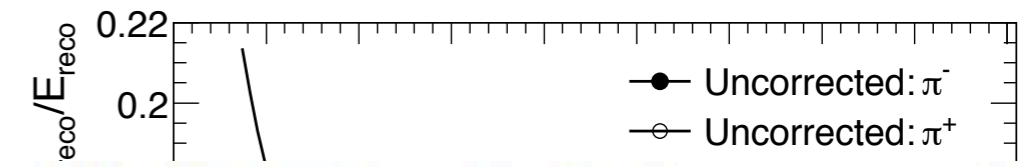

Shower in one Spiroc

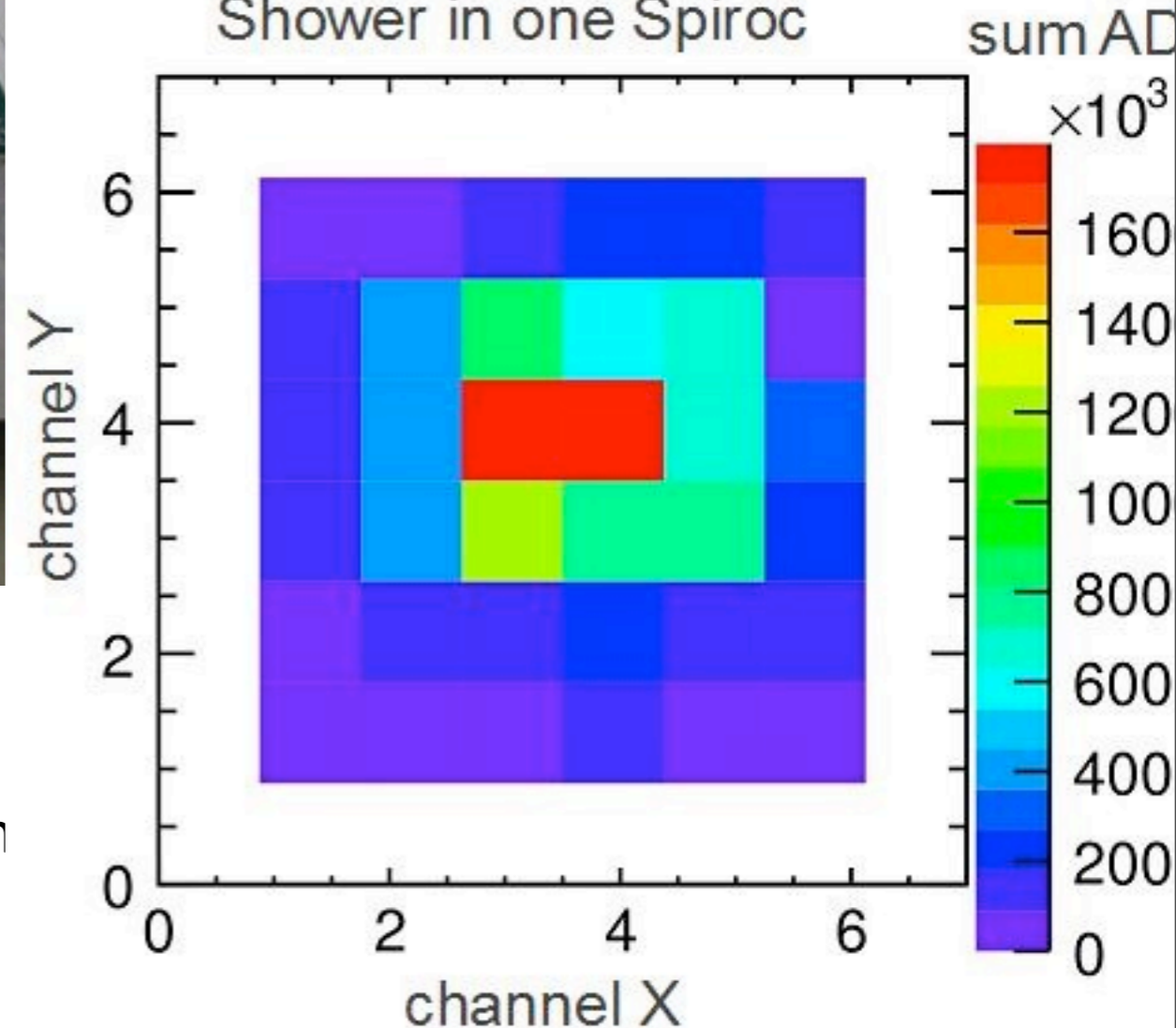

First units (144 channels) of technological demonstrator currently in test beam: - embedded electronics, power pulsing, online zero suppression channel-by-channel auto-trigger, time stamping

The Semi-Digital HCAL

- Glass RPCs with 1 cm² pads
 - 3 thresholds per channel: allows to keep linearity to higher energies, improved resolution at high energies compared to purely digital mode

Full 1 m³ technological prototype with 430k channels & power-pulsing successfully tested in beam

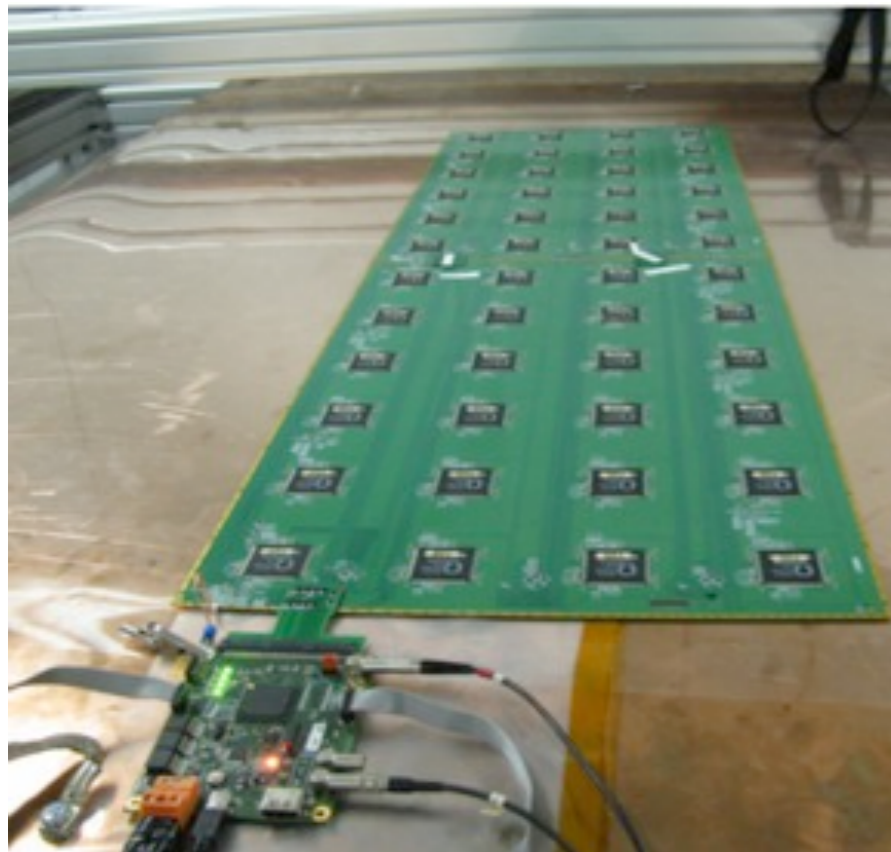
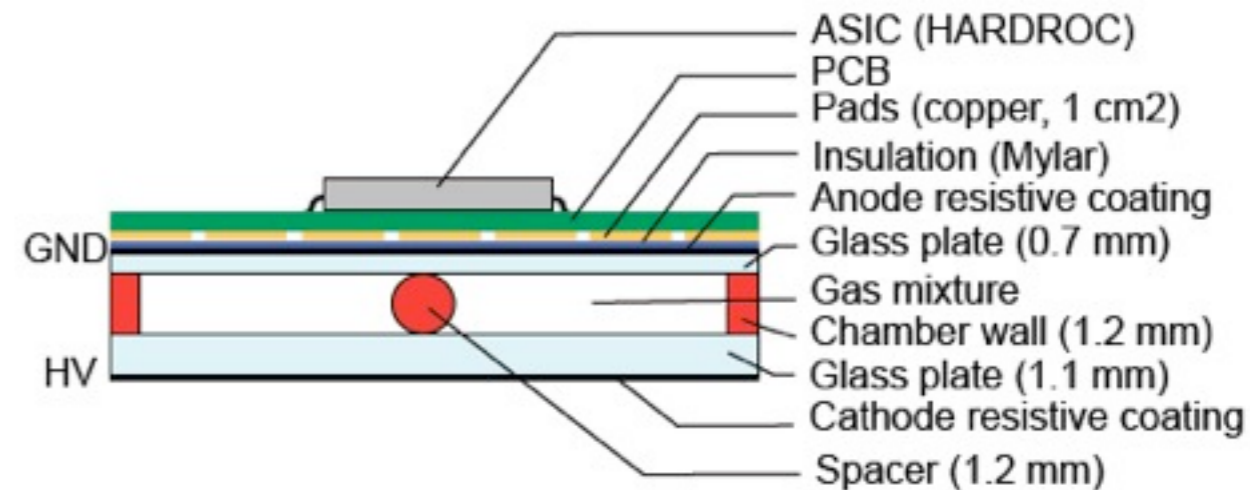

One nice (3D?) event display showing the three thresholds

Linearity / Resolution, currently under review

Forward Calorimeters

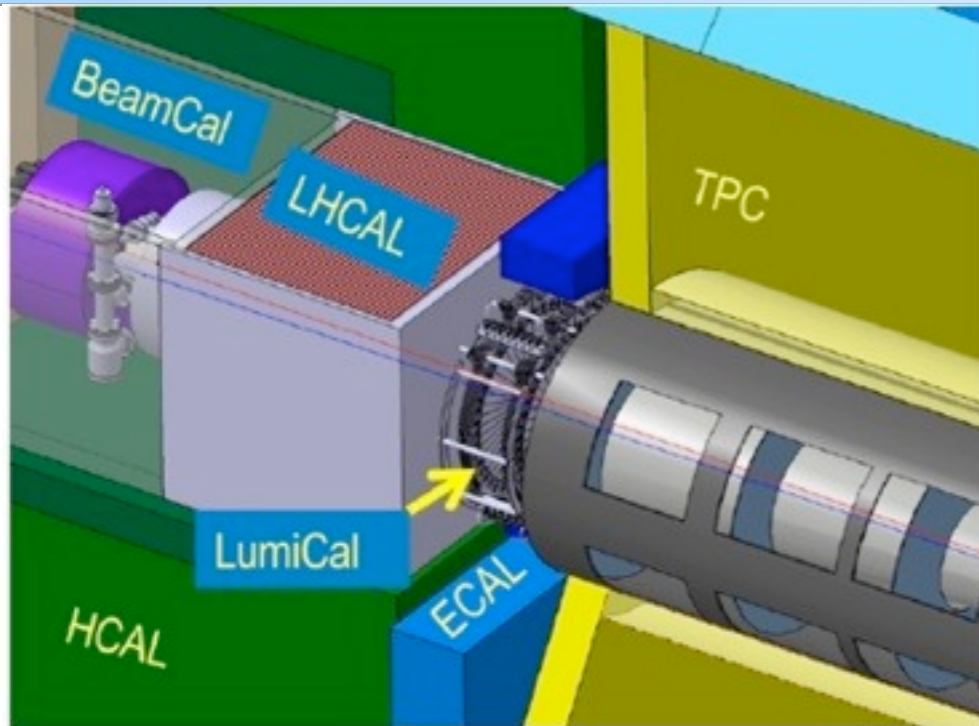

- Luminosity measurement at the 10^{-3} level with LumiCal
- Bunch-by-bunch luminosity monitoring and fast feedback for beam steering with BeamCal
- Extended coverage to low polar angles
- ▶ The only subsystems with substantial radiation hardness requirements!

Silicon sensors for LumiCal - tested in beam

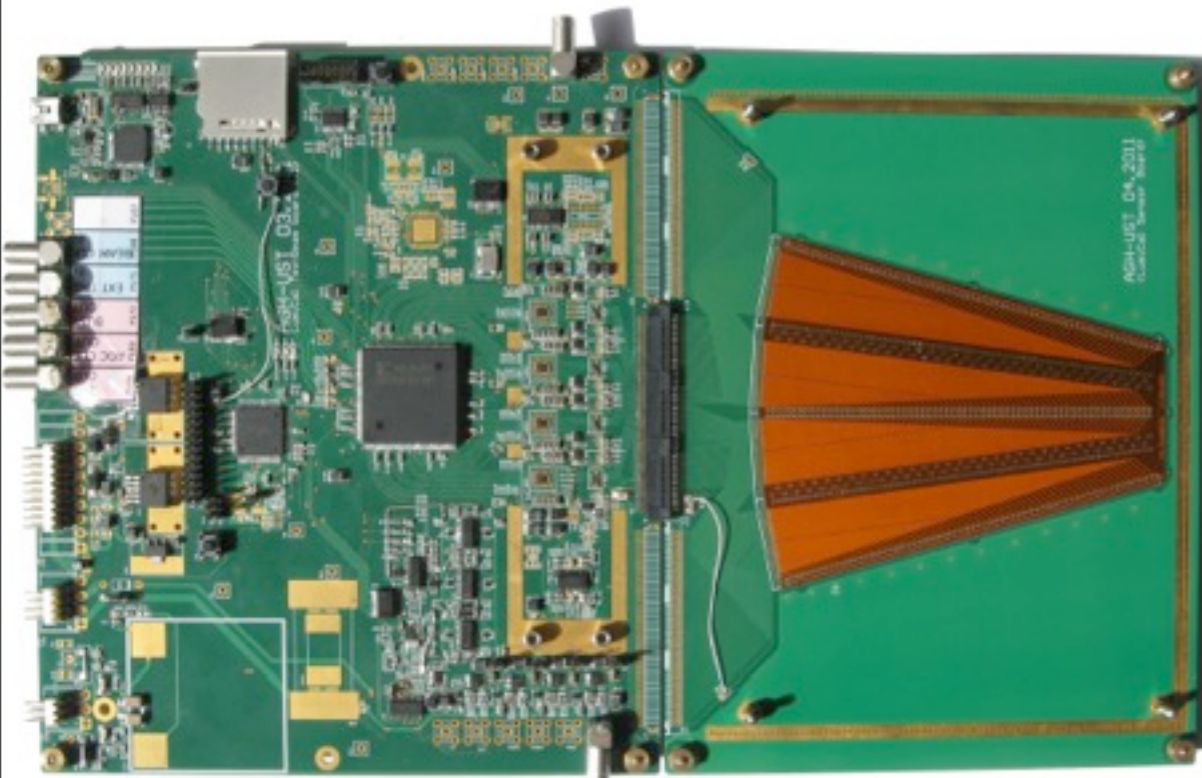

GaAs sensors and CVD Diamond for BeamCal

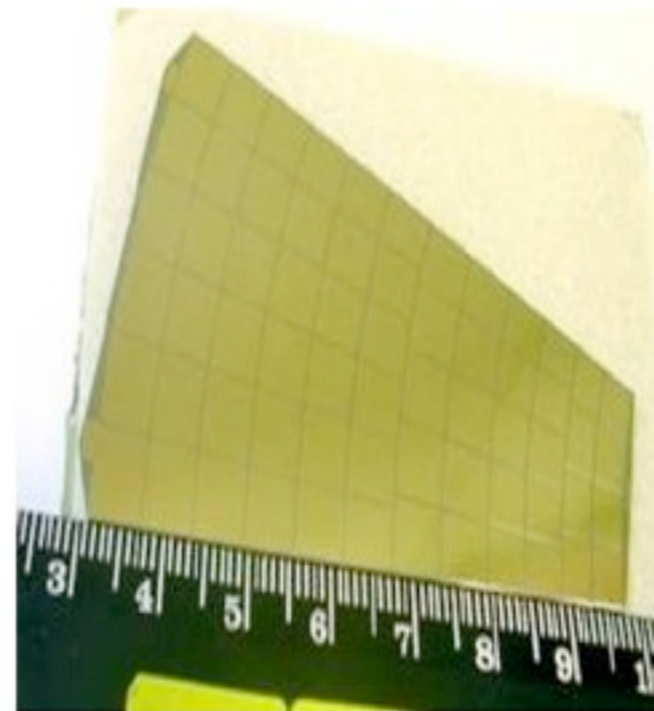

CVD Diamond shows excellent radiation hardness

GaAs shows a reduction of the charge collection efficiency to 20% after 7 MGy, still sufficient for MIP detection

Muon System, Yoke and Coil

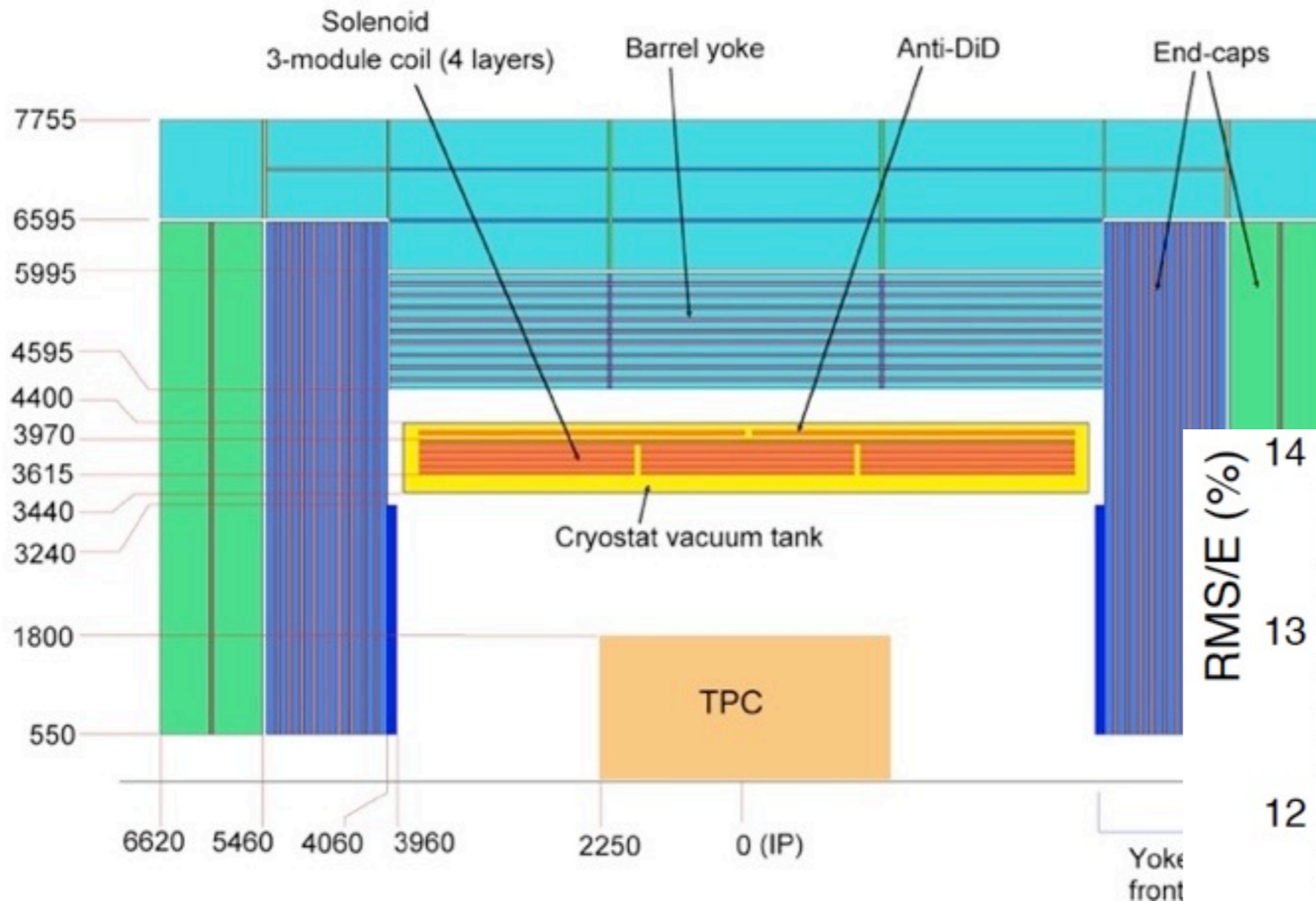

Default operations at 3.5 T, magnet designed for 4 T to allow flexibility at higher energy

- Instrumented iron yoke: Muon tracking and tail-catching
- ~ 10 mm thick, ~ 30 mm wide up to 2.7 m long extruded scintillator strips with SiPM readout

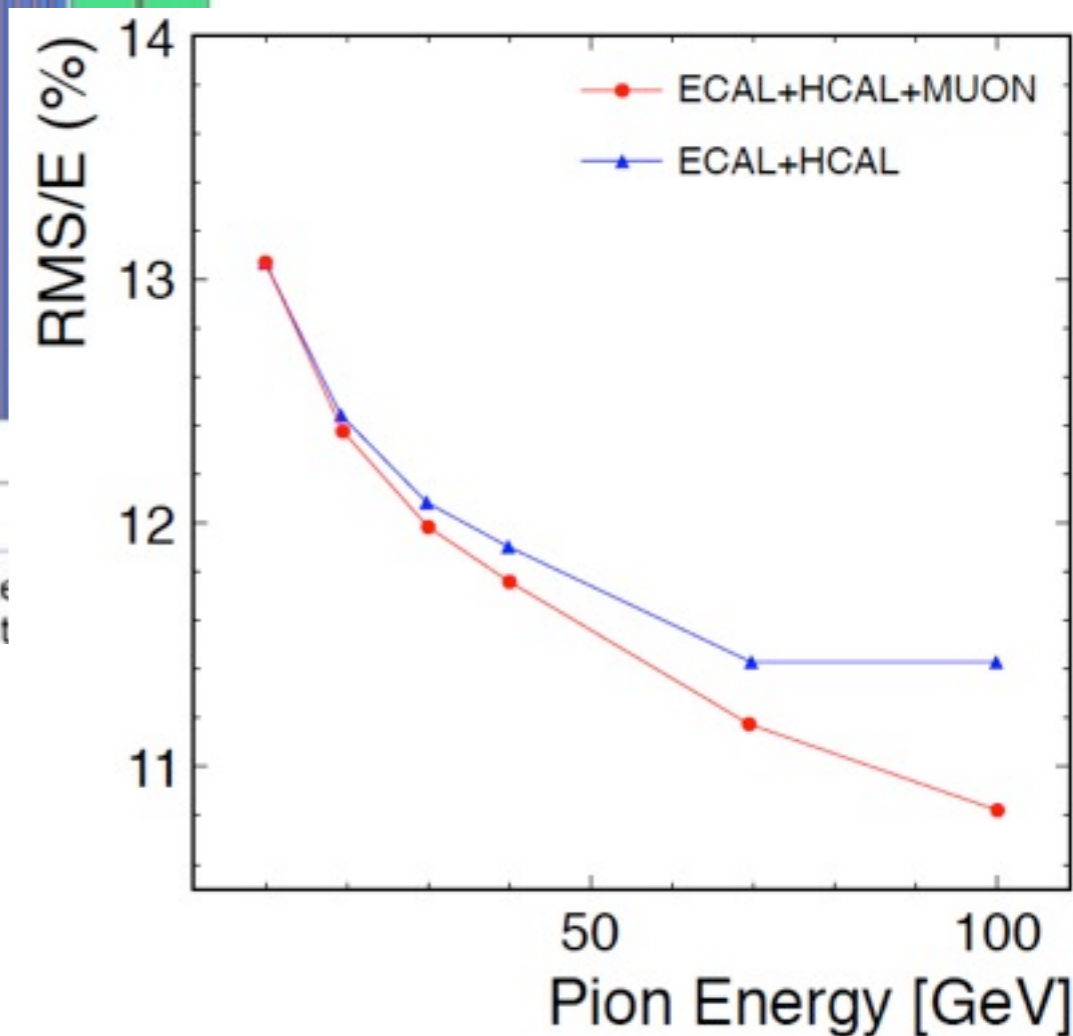

The ILD Detector System

ILD Mechanical Design

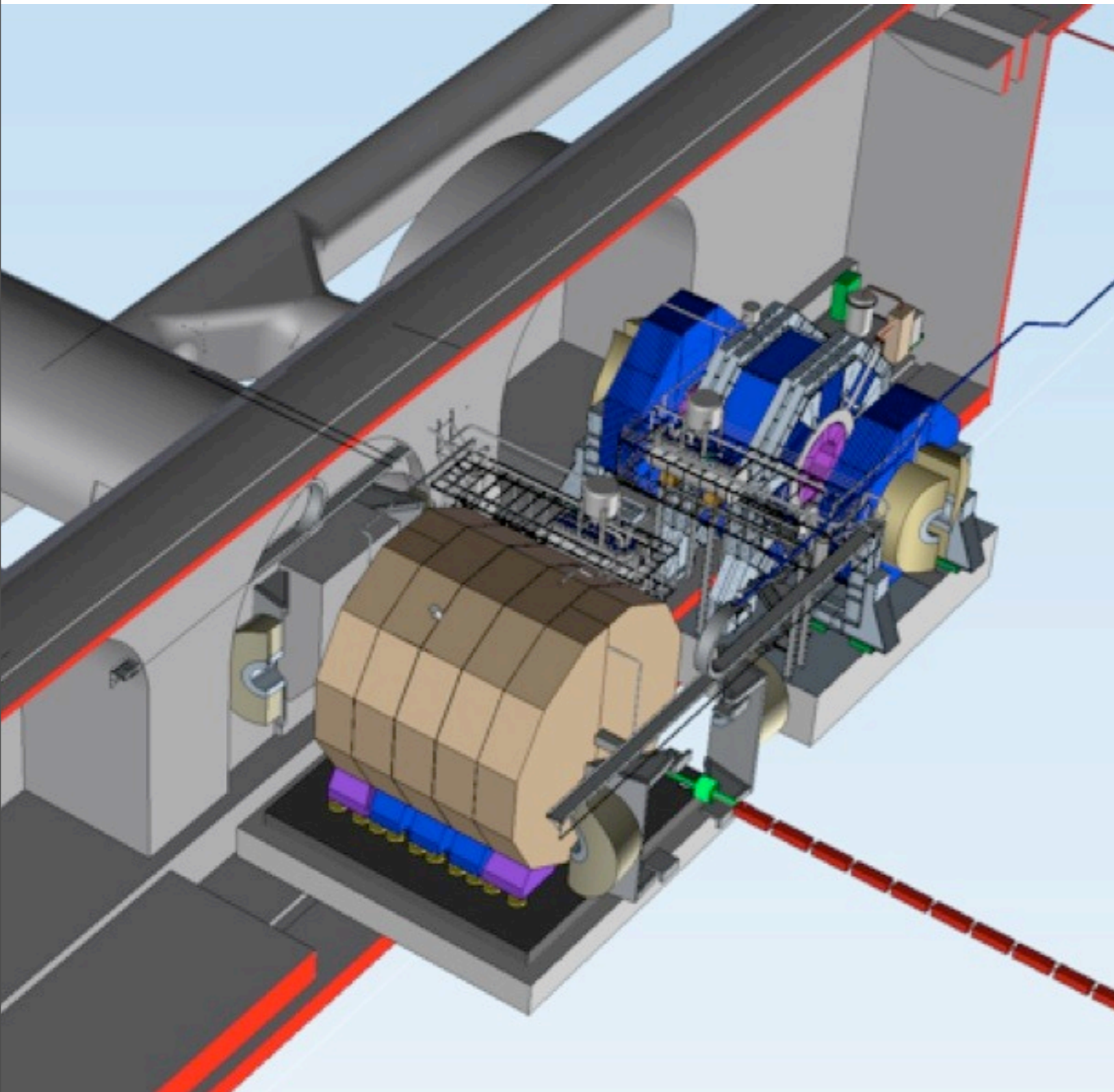

- 5 Yoke rings
 - Mounted on air cushions for easy moving during assembly / dis-assembly / maintenance
- Central ring carries cryostat and solenoid:
 - Supports calorimeters, TPC and outer Si trackers
 - Inner detector & beam pipe supported from TPC

ILD Integration

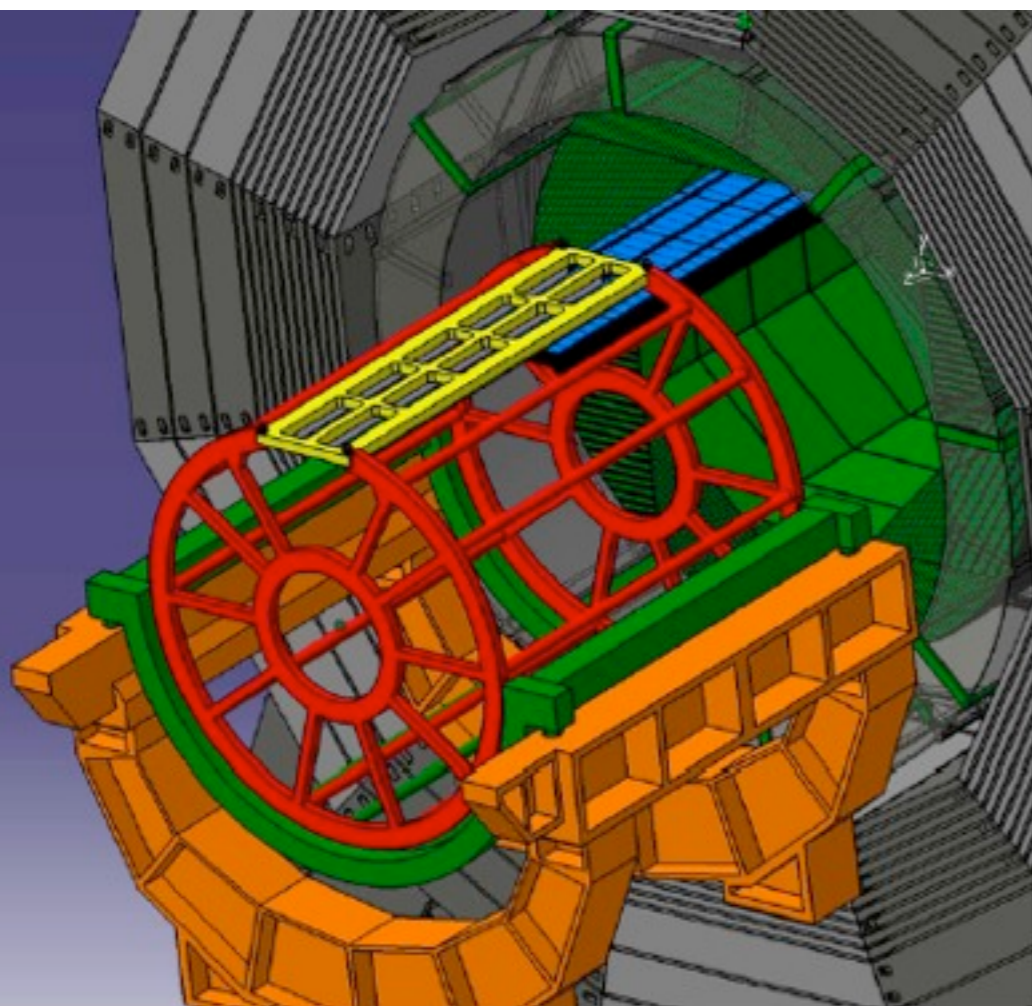

- Assembly strategy with dedicated installation fixtures

- Service paths inside of the detector for power, data, cooling

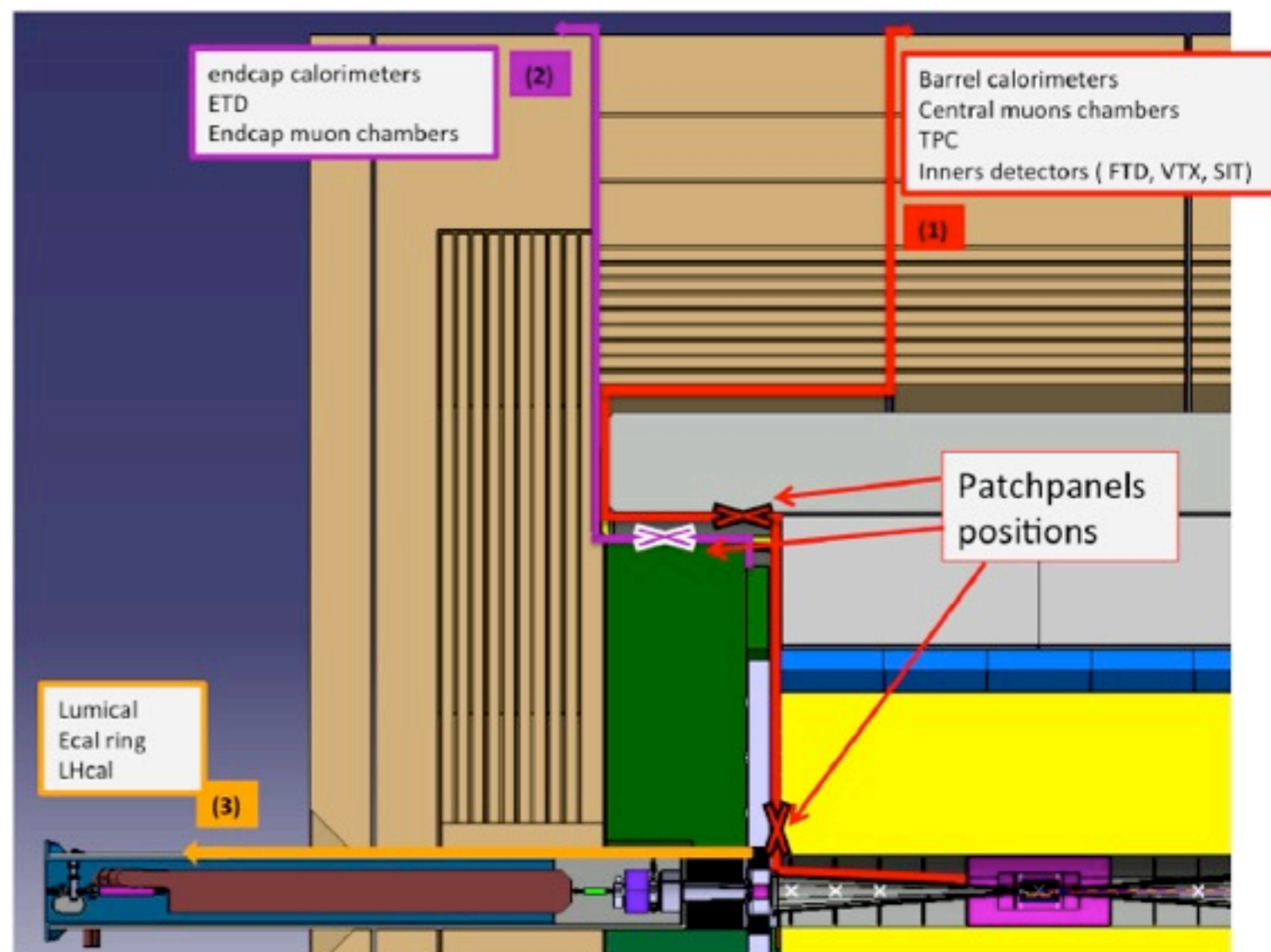

The Experimental Hall

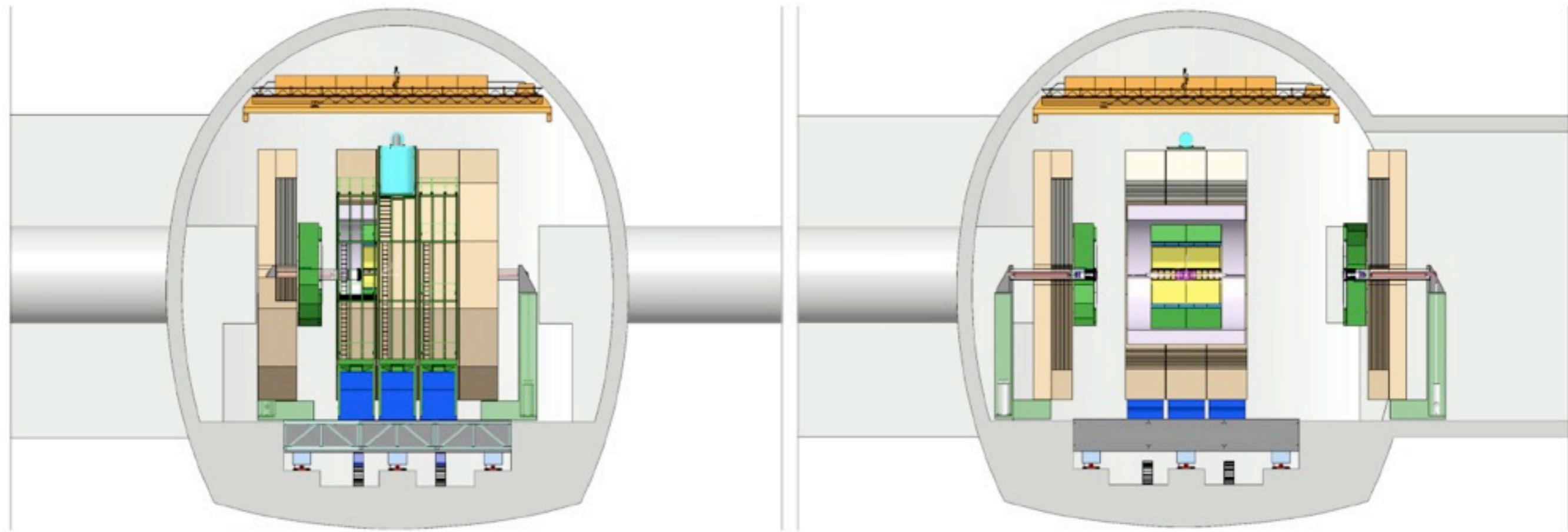

- Size of cryostat defines minimum diameter of access tunnel required for installation
 - For vertical access: Assembly of yoke rings and central detector system within cryostat on surface: 18 m diameter required
 - For horizontal access: Assembly of yoke rings and other large components in detector hall: > 8.7 m diameter required

ILD Software & Performance

ILD Simulation & Reconstruction

- Significant enhancements compared to the LOI
 - Increased realism in the detector description
 - Realistic geometry of most subsystems: Individual modules in trackers, engineering details (mechanical supports, electronics, cooling, cabling, ...)
 - Inclusion of dead material, cracks, ...
 - ▶ Material budget estimates based on R&D activities
 - Improved reconstruction software
 - New generation of PandoraPFA
 - Proper treatment of silicon strips
 - Completely new Kalman-Filter-based tracking
 - New flavor tagging based on boosted decision trees trained with fully simulated events

ILD Material & Performance

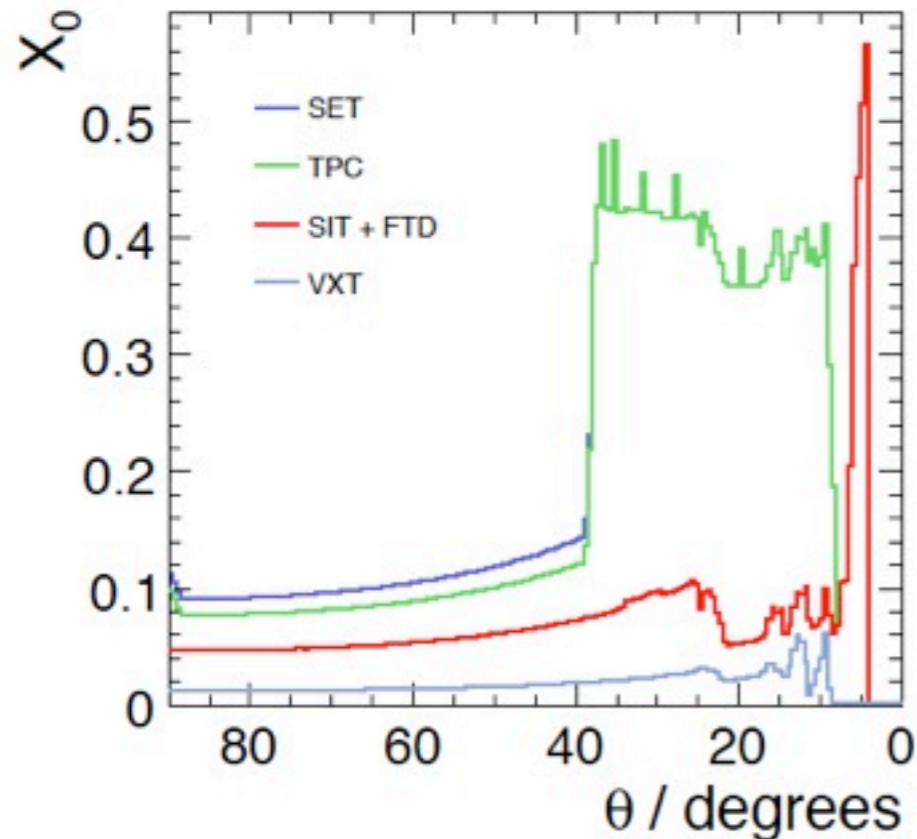

- Realistic description of material budget

Tracking or flavor tagging performance

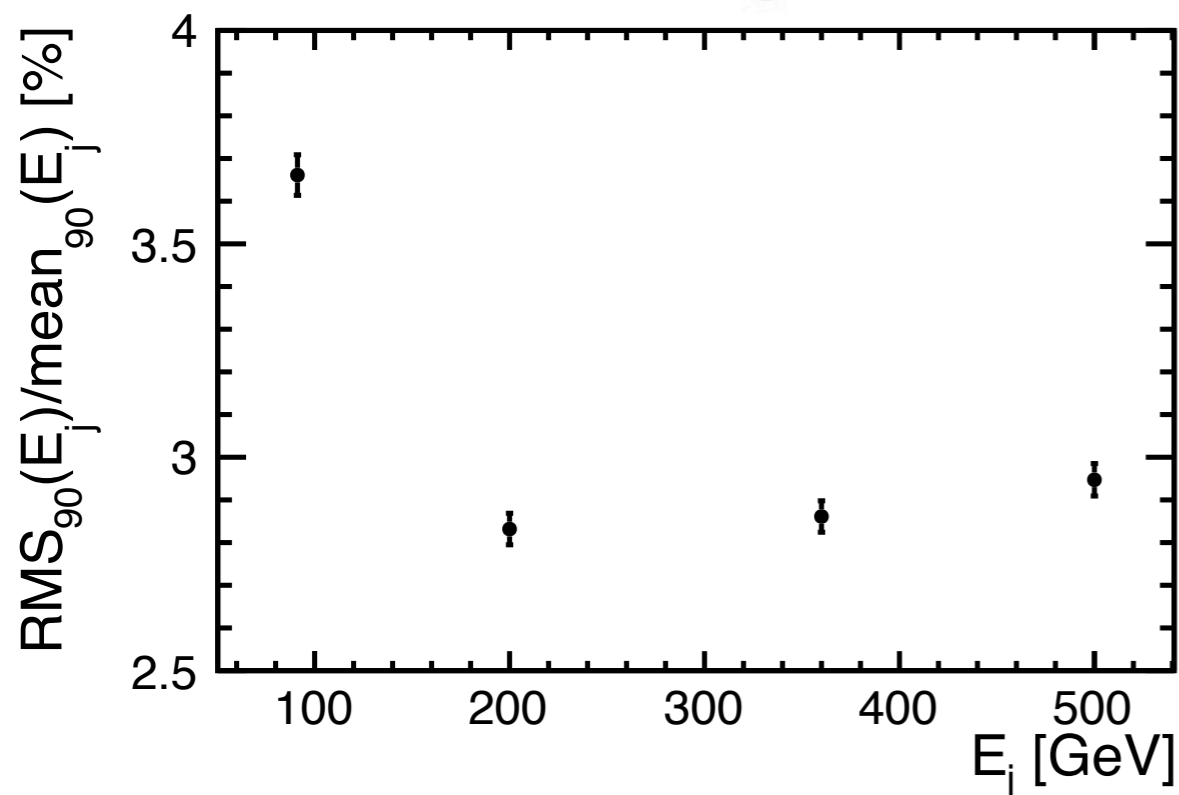

- PandoraPFA performance exceeding requirements over wide energy range

Do we dare to show something here? If yes, which analysis?

Something on $gg \rightarrow \text{had}$ background mitigation with k_t jet finding?

Summary