

Advances in Superconducting RF Technology for the ILC

A. Yamamoto, C. Adolphsen, J. Carwardine, S. Fukuda, R. Geng, C. Ginsburg, E. Harms, H. Hayano, E. Kako, J. Kerby, L. Lilje, C. Nantista, N. Ohuchi, T. Peterson, P. Pierini, M. Ross, T. Shidara, and N. Walker

Abstract—Superconducting RF is an enabling technology for the International Linear Collider (ILC), the ILC Global Design Effort has led R&D programs to push the limits of SRF cavities and associated technologies. This report summarizes the progress in development for superconducting RF cavity technology during the Technical Design Phase for the ILC since 2007.

Index Terms—ILC, linear accelerator, linear collider, particle accelerator, superconducting RF technology, SCRF cavity.

I. INTRODUCTION

THE International Linear Collider (ILC) is proposed as the next energy-frontier electron-positron accelerator to be built with a global cooperation [1 - 3]. The ILC accelerator is based on SCRF accelerator technology, as recommended by the International Technology Recommendation Panel [4] and endorsed by the International Committee for Future Accelerators. The ILC Global Design Effort (ILC-GDE) was launched to advance the accelerator design and R&D efforts in 2005. It published the Reference Design Report (RDR) in 2007 [2], and the Technical Design (TD) phase has been coordinated since 2007. The ILC design aims at to achieve a center-of-mass energy of 500 ($=2 \times 250$) GeV with two 11-km long main linacs, based on the SCRF accelerator technology. The technical design work and R&D efforts have significantly progressed during the TD phase, the Technical Design Report (TDR) are going to be completed in 2012. Figure 1 show the general layout, and Table 1 summarizes the design parameters.

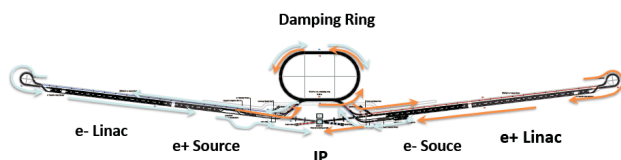

Fig. 1. ILC Accelerator Layout updated in the Technical Design Phase.

Manuscript received 9, October, 2012.

This work was coordinated by ILC Global Design Effort (GDE).

Akira Yamamoto, S. Fukuda, H. Hayano, E. Kako, and N. Ohuchi, T. Shidara are with KEK, Tsukuba, Japan, (phone: +81-29-864-5459; fax: +81-29-864-3209; e-mail: akira.yamamoto@kek.jp).

C. Adolphsen, M. Ross, and C. Nantista are with SLAC, Menlo Park, CA, USA.

J. Carwardine is with ANL, Chicago, IL, USA

R. Geng is with JLab, Newport News, VA, USA.

C. Ginsburg E. Harms, J. Kerby (currently at ANL), and T. Peterson are with Fermilab, Batavia, IL, USA.

L. Lilje and N. Walker are with DESY, Hamburg, Germany.

P. Pierini is with INFN, LASA, Milano, Italy.

TABLE I. ILC ACCELERATOR DESIGN PARAMETERS.

Parameter	RDR	TDR
	(2007)	(2012)
Energy (GeV)	500	500
L (cm ⁻² s ⁻¹)	2×20^{34}	1.5×20^{34}
Beam current (mA)	9	5.8
Beam Rep. (Hz)	5	5
Bunch spacing (ns)	369	554
Bunch train length (μ s)	1.0	0.727
Numbers of bunches	2625	1312
Cav. Grad. (MV/m)	31.5	31.5
# 9-cell cavity	15,941	16,024
# Cryomodule	1,824	1,855
# RF Station	646	413(KCS) / 378 (DKS)
# Cryogenic station	10	12 (KCS) / 10 (DKS)

II. ILC ACCELERATOR DESIGN UPDATE

The ILC accelerator design has been updated since middle of the TD phase [5], and motivated by i) the performance to be achieved with overall cost containment and balances among sub-systems, ii) optimized system functionality, iii) more complete and robust design, and iv) further optimized R&D plans. The major design updated includes:

- A Main Linac to achieve a beam energy of 250 GeV using superconducting RF cavities with an average accelerating gradient of 31.5 MV/m allowing a gradient spread of +/-20%,
- A single-tunnel solution for the Main Linac, with two possible variants for the High-Level RF configurations of Klystron Cluster Scheme (KCS) and Distributed Klystron Scheme (DKS).
- Undulator-based positron source located at the high-energy end of the electron Main Linac (250 GeV),
- Integration of the positron and electron sources into a common “central region beam tunnel”, together with the Beam Delivery System, resulting in an overall simplification of civil construction in the central region.
- A beam-power parameter set with the number of bunches per pulse reduced by a factor of two,
- Reduced circumference of Damping Rings (~3.2 km) at 5 GeV with a 6 mm bunch length,

III. ADVANCES IN SCRF TECHNOLOGY

In the Technical Design phase, four critical SCRF main linac R&D topics were identified and have been pursued as follows [3,5, 6, 7]:

- **S0:** SCRF cavities to exceed a gradient of 35 MV/m in individual performance test in vertical position,
- **S1:** Cavity-string in cryomodule to perform at 31.5 MV/m on average.
- **S2:** Cryomodule-string to perform with beam acceleration, including associated systems such as RF power systems, cryogenics, and beam diagnostics.
- **Industrialization:** Study of cost-effective production technology for SCRF accelerator components.

The notation of *S0*, *S1*, and *S2* refers to the shorthand for the individual goals introduced in the RDR period. Figure 2 shows the general SCRF R&D plan in the TD phase together with the foreseen development.

Year	07	2008	2009	2010	2011	2012
Phase	TDP-1			TDP-2		
Cavity Gradient in test to reach 35 MV/m	→ Yield 50%			→ Yield 90%		
Cavity-string to reach 31.5 MV/m, with one-cryomodule	Global effort for string assembly and test (DESY, FNAL, INFN, KEK)					
System Test with beam acceleration	FLASH (DESY), NML/ASTA (FNAL) QB, STF2 (KEK)					
Preparation for Industrialization	Production Technology R&D					
Communication with industry:	1 st Visit Vendors (2009), Organize Workshop (2010) 2 nd visit and communication, Organize 2 nd workshop (2011) 3 rd communication and study contracted with selected vendors (2011-2012)					

Fig. 2. The main goals and timeline for SCRF R&D established at the beginning of the TD phase.

Figure 2 show the SCRF R&D plan in the Technical Design phase. Their highlighted results are summarized as follows:

- Successful construction and functioning of SCRF facilities at DESY [8], FNAL-ANL [9-11], JLab [12], and KEK [13].
- Identification of the preferred process for consistent production of 35 MV/m cavities (worldwide), and successful demonstrations of the TDP goal of a *production yield* of 90% [14],
- Establishment of “plug-compatibility” for the cavity and the interface design,
- Global collaboration to develop and to evaluate an international cryomodule (S1-Global) hosted at KEK, enabling exploration of plug-compatible design philosophies and evaluating the technologies.

- Development and tests of cryomodules with beam acceleration, such as FLASH at DESY, ASTA/NML at Fermilab, and STF at KEK [5].
- Associated system R&D such as HLRF/LLRF, cryomodule including quadrupoles and beam position monitor, and cryogenics.
- Study of SCRF mass-production, including R&D for cost-effective mass production.
- Encouragement of new cavity vendor participation, in cooperation with laboratories, for qualification in the Americas and Asia, to complement those already existing in Europe, so as to scope global mass production for the ILC.

Table II summarizes the cavity specifications/requirements, and Table III lists surface preparation process specified to satisfy the ILC field gradient requirement. Figure 3 shows boundary conditions for the “plug-compatibility” in the cavity design and fabrication shared with the global cooperation.

TABLE II
ILC SCRF CAVITY DESIGN AND FABRICATION PROCESS.

Parameters	Value
Design:	
Type of accelerating structure	Standing wave
Accelerating mode,	TM ₀₁₀ , π mode
Fundamental frequency	1.3 GHz
Gradient in operation	31.5 MV/m +/-20 %
Quality factor in operation	≥ 1 x 10 ¹⁰
Gradient in qualification	35 MV/m +/- 20 %
Quality factor in qualification	≥ 0.8 x10 ¹⁰
Inner diameter at Iris	70 mm
Outer diameter at Equator	206 mm
Cell to cell coupling	1.87%
Number of cells	9
Active 9-cell length	1,038.5 mm
Physical length b/w beam-flanges	1,247.4 mm
Input-coupler pitch	1,326.7 mm
R/Q	1036 Ω
Geometry factor	270 Ω
E _{peak} /E _{cc}	2.0
B _{peak} /E _{acc}	4.26 mT/MV/m
Tunable range	+/- 300 kHz/mm
Δf/ΔL	315 kHz/mm
Number of HOM couplers	2

TABLE III. CAVITY FABRICATION AND PREPARATION.

Step	Contents
Mechanical fabrication	Nb-sheet preparation and forming of half-cell, Assembly of 9-cells with electron-beam welding (EBW)
Surface preparation	1 st Electro-polishing (Bulk-EP, 100 ~ 150 μm) Ultrasonic degreasing/Ethanol rising /Flash EP High-pressure, pure-water rinsing Hydrogen degassing (Heating in vacuum, > 600 C) Tuning of field flatness, 2 nd EP (10 ~ 20 μm) Ultrasonic degreasing/ethanol rinsing/Flash-EP High-pressure, pure-water rinsing, Assembling with input-couplers/antennas in clean room Baking (~120 C)
Performance test	RF testing at 2K with thermometry, x-ray measurement, and quench/field-emission localization,

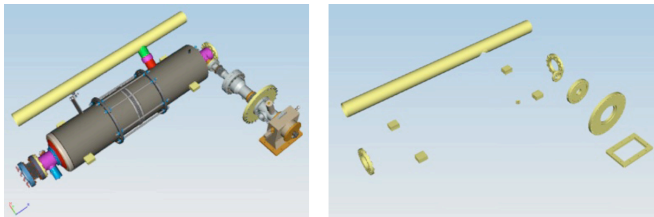

Fig. 3. Plug-compatible interfaces for the SCRF cavity.

The progress in each R&D subject is summarized as follows.

A. Cavities gradient

Figure 4 shows progress of the ILC-SCRF 1.3 GHz cavity gradient R&D systematically monitored by the ILC SCRF global database team [14]. It shows differential production yield in each 1 ~ 2 year period (a) for the 1st surface treatment process and (b) for the 2nd process. In the 2nd pass, the production yield achieved 75% of cavities achieved >35 MV/m, and 94% of cavities achieved >28 MV/m considering the cavity tests taking place in 2010-2012. It should be noted that the average gradient reached 37.1 MV/m.

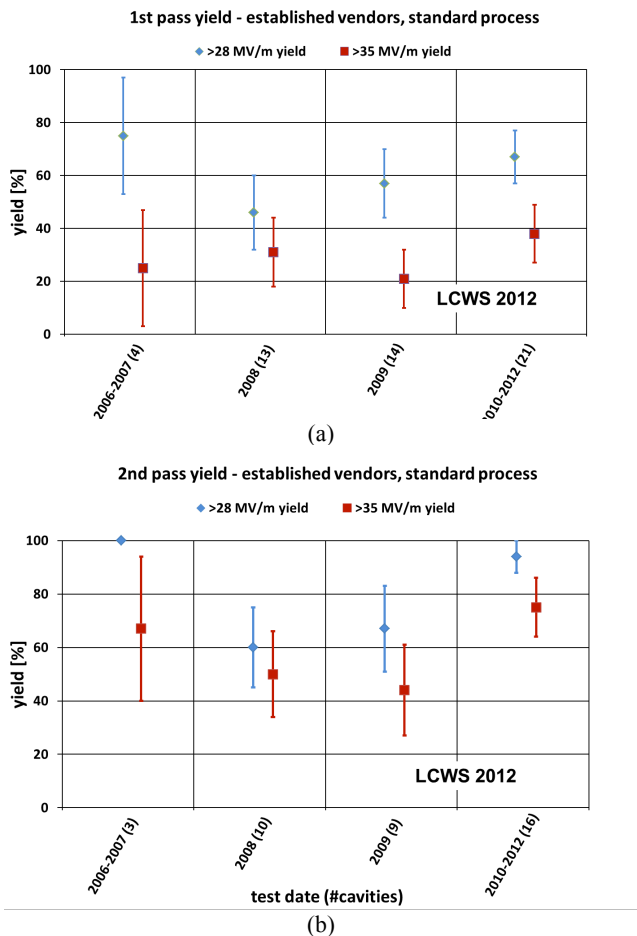

Fig. 4: Progress of the ILC-SCRF 1.3 GHz cavity gradient R&D (a) the production yield in the 1st pass process, with the data available since 2006, and (b) the production yield in the 2nd pass. [9]. The blue points are for >28 MV/m yield and red points are for >35 MV/m yield.

Ongoing efforts to improve cavity production yields include applying mechanical tumbling [15] or localized grinding [16] for removal of performance-limiting defects and centrifugal barrel polishing to the baseline cavity process recipe. Various cavities were successfully repaired, by using these two methods. These repairs may be included as a part of the baseline recipe in near future [17, 18].

In the TD phase, several manufacturers have engaged in the production of cavities [6]. While originally only two companies provided cavities qualifying for the ILC demands we now see companies in all three regions successfully manufacturing high-gradient cavities as listed in Table IV. The number of successfully tested cavities achieving the ILC specification has now reached several dozen.

TABLE IV.
SCRF CAVITY VENDERS AND LABORATORIES, ACHIEVING THE 35 MV/M GRADIENT GOAL.

Year / # cavity	Cavity manufactures	Laboratories
2006 / 10	Accel, Zanon	DESY
2011 / 41	RI, Zanon, AES, MHI	DESY, JLab, Fermilab, KEK
2012 / 45	RI, Zanon, AES, MHI, Hitachi	DESY, JLab, Fermilab, KEK, Cornell-U

B. Cavity-string gradient in Cryomodule

A prototype cryomodule for the European XFEL program has achieved an averaged field gradient of 32 MV/m, in the FLASH beam line operation, as shown in Fig. 5, and as an important part of the milestone in the ILC TD phase R&D effort [8].

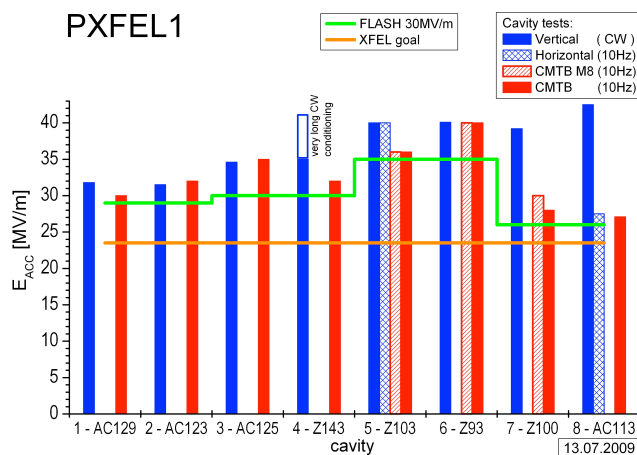

Fig. 5: Field gradient achieved in cryomodules developed at DESY/FLASH-PXFEL1 [8].

A global collaboration on a cryomodule assembly and test, so called ‘S1-Global’, was carried out, and contributed by FNAL, SLAC, DESY, INFN and KEK. Each two TESLA-type cavities were contributed by FNAL and DESY, respectively, and four TESLA-like-type cavities were contributed by KEK. Each half cryomodule was contributed

by INFN and KEK. Figure 6 shows the cavities contributed to the S1-Global program. It should be noted that the S1-global program realize an important demonstration for “plug-compatible” assembly keeping individual feature of the cavities contributed [19-21]. Figure 7 shows the cavity gradient according to the test stage: (blue) individual cavity performance, (red) individual cavity performance after cryomodule assembly, and (green) 7-cavity-string gradient test. The S1-Global succeeded to demonstrate a cavity-string gradient of 26 MV/m on average, based on the cavity individual performance of 30 MV/m on average. The plug-compatible assembly of various cavities and the respective interfaces has been verified successfully. Figure 8 shows a snap shot during the S1-Global experiment.

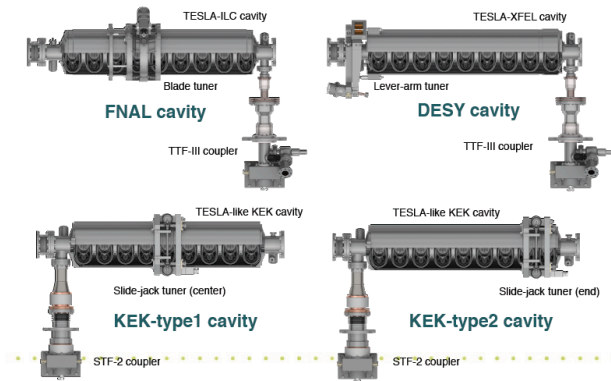

Fig. 6. Various cavities contributed to the S1-Global program.

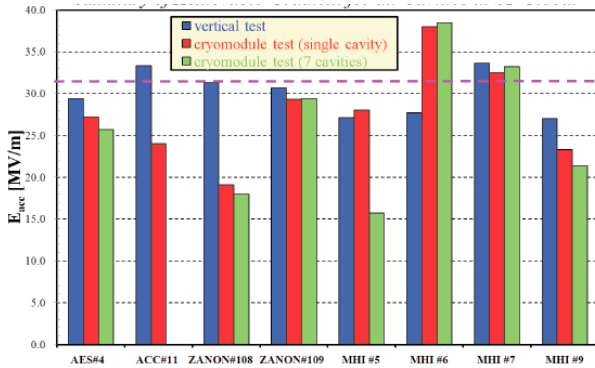

Fig. 7. The S1-Global cavity gradient performance in (blue) individual cavity test, (red) individual cavity test after cryomodule assembly, and (green) in 7-cavity-string test.



Fig. 8. A photo of the S1-Global cryomodule and global participation.

Figure 9 shows a progress in the cryomodule (CM1) performance test at Fermilab/NML-ASTA. [11].

As an important message from the cryomodule performance tests, the gradient degradation has been observed after installation into the cryomodules, and it will be an important subject to be settled beyond TDR.

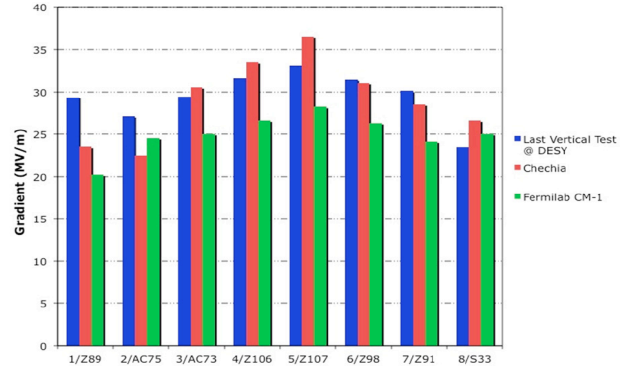

Fig. 9: Field gradient achieved in the CM1 cryomodule developed at Fermilab10].

C. Progress in the SCRF Beam Test Facility

The beam acceleration tests by using SCRF beam test facilities have progressed at DESY/FLASH and KEK/STF, and will be realized soon at Fermilab/NML-ASTA. Major progress is summarized in Table 3 [22, 23].

TABLE V. PROGRESS IN SCRF BEAM TEST FACILITIES.

Subject	R&D goal	Achievement	Facility
- High beam power and long bunch trains (Feb. 2009)			
Pulse current	9 mA	9 mA	FLASH
Bunches per pulse	2400 x 3 nC	1800 x 3 nC 2400 x 2nC	FLASH
Cavity gradient	31.5 MV/m +/-20 %	> 30 MV/m with 4 cavities	FLASH
- Gradient operating margins (Feb. 2012):			
Gradient flatness	2%ΔV/V (0.8ms, 5.8mA)	<0.3% ΔV/V (0.8ms, 4.5mA)	FLASH
Gradient margin	3 % to quench limit	5% to limit (0.8ms, 4.5mA)	FLASH
Energy stability	0.1% rms	<0.15%(0.4ms) <0.02% (5 Hz)	FLASH
- Beam duration (April 2012) :			
Pulse width	1 ms	1ms	STFQB

D. Associated Engineering Design and R&D

The ILC cryomodule design has been established with two design variants: a longer design consisting of an 8-cavity string plus one quadrupole at the centre, and a shorter design consisting of an 8-cavity string. The removal of the bottom 5 K shield has been explored, and it will be a subject to be further investigated beyond TDR [24, 25].

The R&D for superconducting magnet using condition cooling has been successfully made [26, 27]. It will help to

assemble the magnet separately from the cavity string assembly requiring specially arranged clean rooms.

In RF power system design, the Klystron Cluster Scheme (KCS) has been proposed as an optimum design for flat-land topography [28]. As an alternate design, the Distributed RF Scheme (DRFS) with 800-kW klystron was once proposed for a mountainous topology, and it was demonstrated during the S1-Gloabal program at KEK [29]. Finally, the Distributed Klystron scheme (DKS) with 10 MW klystrons has been chosen as the baseline for the mountainous topography. The KCS and DKS HLRF power system concepts are shown in Fig. 10 and Fig. 11, respectively [34].

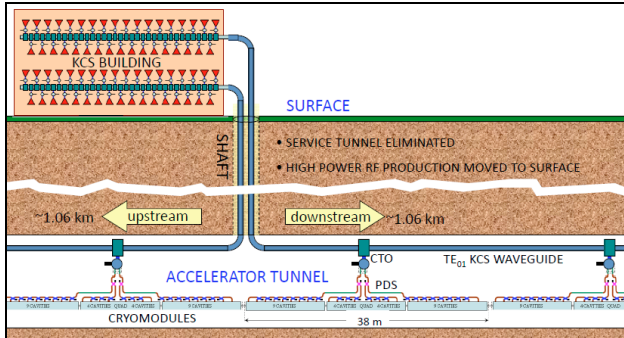

Fig. 10: The KCS concept for the main linac HLRF power distribution system considered in flat-land site topography.

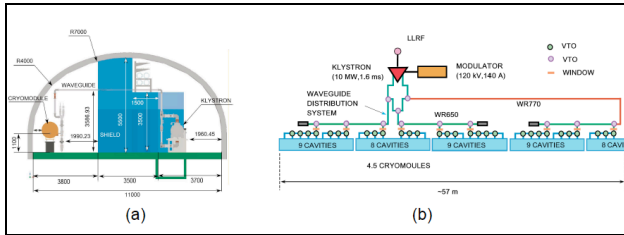

Fig. 11: The DKS concept for the main linac HLRF power distribution system considered in mountainous site topography finalized in TDR.

Marx modulator development has been successful at SLAC as a baseline power source [30]. The LLRF control study succeeded in adapting various cavity tuner designs [27,28], and demonstrated successful handling of cavity string performance variation and proved the general feedback operation with a RF power overhead margin below 10% [31, 32].

The scale and feature of the cryogenic system for the ILC are expected to be similar to the LHC accelerator cryogenics system, which also operates at 2 K. Figure 12 shows the conceptual diagram for the ILC cryogenics layouts in flat land topography. The conceptual design for this system is in progress [33], and a design pressure of 2 bar was adapted recently for the cavity, cryomodule and cryogenic system. Further system engineering will be carried out to determine the most cost effective design in view of both construction and long-term operation, in reference to the extensive experience at CERN-LHC.

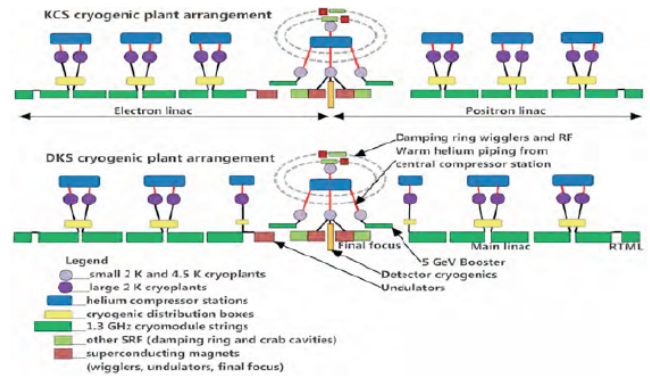

Fig. 12. Cryogenics facility layout for the ILC cryogenics.

IV. R&D BEYOND TDR

Technical R&D has progressed in the Technical Design Phase, as described above, and the TD Report is to be completed in 2012, as given in the time chart progress in Fig. 13. Further R&D tasks to be addressed beyond TDR completion include:

- Achievement of higher gradients, with an R&D target of 45 MV/m, motivated by further cost-effective cavity production and applying for the energy upgrade phase,
- Mitigation of the field gradient degradation after installation into the cryomodule.
- Preparation for industrialization with optimization of mass-production models in close communication with industry.

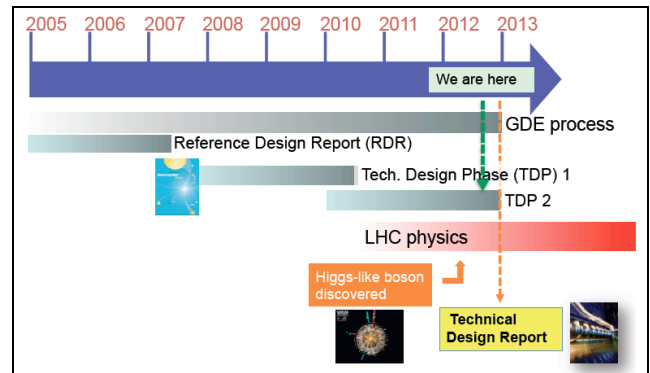

Fig. 13: Time flow for the ILC Technical Design Phase.

Figure 14 illustrates progress in the gradient of L-band (GHz) SCRF niobium cavity gradient R&D impact on SCRF linacs and future prospect [35]. Based on these results, it is believed that the SCRF cavity-gradient goal for 1TeV ILC upgrade is reachable, with expecting the further gradient improvement with the target of 45 MV/m mentioned above. The most promising path may be a combination of large grain and alternate-shape cavities processed by the current baseline recipe for the final surface processing.

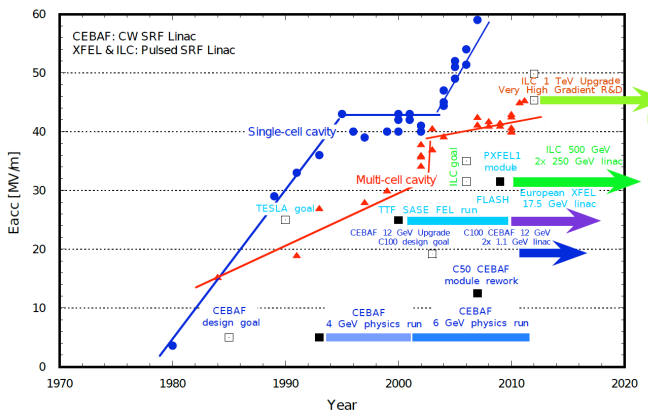

Fig. 14: SCRF cavity field gradient progress and future prospect.

V. SUMMARY

The ILC TD phase has been successfully carried out, and the TDR will be completed in 2012. It is a conclusion that ILC can be realized, based on the TDR technology. It may be a possibility to consider a staged scenario for ILC construction, starting with lower energy, depending on the physics output from LHC experiments, and to study, first, the Higgs-like boson in an energy range of 126 GeV. Beyond the TDR completion, R&D should be extended, focusing on preparation of industrialization of major components with international industrial cooperation, maintain plug-compatible interface conditions for the best cost-effective approach.

ACKNOWLEDGMENT

We would thank all of worldwide ILC-GDE Collaborators for their cooperation to advance the Technical Design, and R&D effort carried out during the Technical Design Phase.

REFERENCES

- [1] International Linear Collider. Available: <http://www.linearcollider.org>.
- [2] ILC Reference Design Report (RDR). <http://www.linearcollider.org/about/Publications/Reference-Design-Report>
- [3] A. Yamamoto et al., IEEE Trans. Appl. Supercond., 29, No. 3 (2009) pp. 1387-1393.
- [4] ITRP Recommendation, (2004); http://www.fnal.gov/directorate/icfa/ITRP_Report_Final.pdf
- [5] The International Linear Collider: A Technical Progress Report (Interim report). <http://www.linearcollider.org/about/Publications/interim-report>
- [6] A. Yamamoto et al., SRF11, Chicago, MOIOA02 (2011). <http://www.jacow.org>
- [7] A. Yamamoto et al., LINAC12, Tel-Aviv, TH3A01 (2012). <http://www.jacow.org>
- [8] D. Reschke et al., SRF11, Chicago, MOIOA01 (2011).

- [9] V. Yakovlev, C. Ginsburg, LINAC12, Tel-Aviv, MO1A03 (2011). <http://www.jacow.org>
- [10] C.M. Ginsburg, LINAC12, Tel-Aviv, MOPB052 (2012). <http://www.jacow.org>
- [11] E.R. Harms et al., LINAC12, Tel-Aviv, MOPB054 (2012). <http://www.jacow.org>
- [12] C. Reece et al., SRF11, Chicago, MOTIOA04 (2011). <http://www.jacow.org>
- [13] H. Hayano et al., to be published in ILC-TDR (2013). <http://www.linearcollider.org>.
- [14] C. Ginsburg et al., to be published in ILC-TDR (2013): <http://www.linearcollider.org>.
- [15] C. Cooper et al., SRF11, Chicago, TUPO025 (2011). <http://www.jacow.org>
- [16] Y. Iwashita et al., LINAC12, Tel-Aviv, MOPB053 (2012). <http://www.jacow.org>
- [17] Y. Yamamoto et al., SRF11, Chicago, TH0101 (2011). <http://www.jacow.org>
- [18] Y. Yamamoto et al., to be published in ILC-TDR (2013). <http://www.linearcollider.org>.
- [19] E. Kako et al., IPAC11, San Sebastian, MOODA02 (2011). <http://www.jacow.org>
- [20] Y. Yamamoto et al., SRF11, Chicago, THIOA01 (2011) <http://www.jacow.org>
- [21] H. Hayano et al., LINAC12, Tel-Aviv, TH1A01 <http://www.jacow.org>
- [22] N. Walker et al., PAC09, Vancouver, WE6F109 (2009). <http://www.jacow.org>
- [23] J. Carwardine et al., to be published in ILC-TDR (2012). <http://www.linearcollider.org>.
- [24] N. Ohuchi et al., IPAC11, San Sebastian, WEP035 (2011). <http://www.jacow.org>
- [25] P. Pierini, T. Peterson, to be described in ILC-TDR. <http://www.linearcollider.org>.
- [26] V. Kashikhin et al., IEEE Trans. Appl. Supercon., 22, 4002904 (2012).
- [27] M. Tartaglia et al., presented at ASC12, Portlan, and to be published in Appl. Supercond. (2013).
- [28] C. Adolphsen, C. Nantista, LINAC12, Tel-Aviv, MOPB044 (2012). <http://www.jacow.org>
- [29] S. Fukuda et al., LINAC10, Tsukuba, MOPO021 (2010). <http://www.jacow.org>
- [30] M. Kemp et al., LINAC12, Tel-Aviv, WE2A02 (2012). <http://www.jacow.org>
- [31] S. Michizono et al., IPAC11, San Sebastian, MOODA02 (2011). <http://www.jacow.org>
- [32] W. Schappert et al., SRF11, Chicago, FRIOA01 (2011). <http://www.jacow.org>
- [33] T. Peterson et al., ICEC-2007, *Adv. Cryog. Eng.* (2008) and to be published in ILC-TDR. <http://www.linearcollider.org>.
- [34] S. Fukuda and C. Nantista et al., to be published in ILC-TDR <http://www.linearcollider.org>.
- [35] R. Geng, to be published in ILC-TDR. <http://www.linearcollider.org>.