

ATF2 - IP Chamber for IP-BPM

Short Status

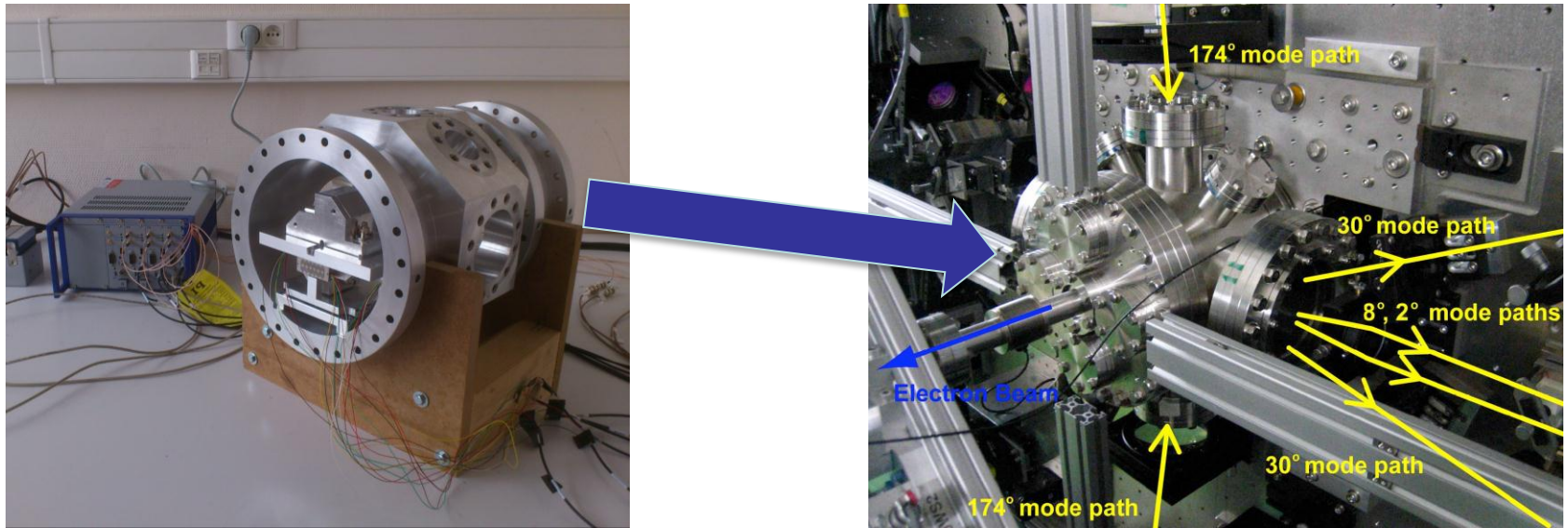

Planning

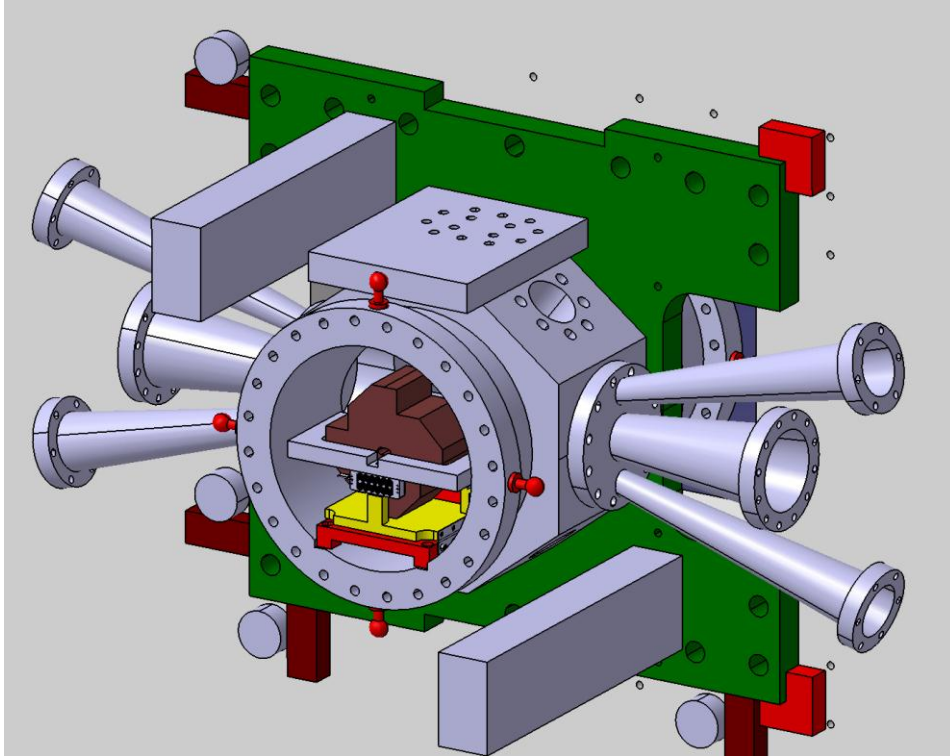

1. Fabrication
 - Downstream fixture : wk 12 ou 13
 - Support for vib. measurement : wk 12
2. Cleaning of BPM disp system : wk 12-13
3. Mounting & tuning of BPM disp system : wk 14
 - (→ Fully done with doublet BPM)
 - (→ Mounting operation manual to do)
4. Paperwork for shipment : wk 14
 - Size, weight and type of importation to be defined
5. Parcels preparation : wk 18
6. Shipment : wk. 20
7. Delivery at KEK : 10 / 15 Days after shipment (→ beg. of June)
8. Installation at KEK : wk. 27-28