



# ILD: A Critic's Perspective

Reduced version for presentation at DESY  
Felix Sefkow, 20.2.2015

*Marcel Demarteau*  
*Argonne National Laboratory*

*September 7, 2014*  
*Oshu City, Iwate, Japan*



**Not me, I hope !!**

# The Process

---



- ❑ In preparation for this presentation consulted about 20 members of the community, either by phone or in person.
- ❑ The distribution of the members polled was approximately: 12 ILD, 4 SiD, 2 CLIC, 2 LCC.
- ❑ The frank discussions with these members are much appreciated. No attribution is made to respect their confidentiality.
  
- ❑ **This presentation reflects my personal observations, using the input receives, made with one goal in mind: to realize this unique opportunity for the ILC project.**
- ❑ **All mistakes are mine; responsibility for all statements rests with me.**

# Outline

- The ILC Paradigm
- ILD
  - The Detector
  - The R&D
  - The Software
  - The Physics Analyses
  - The Organization and Management
- Our Challenge and Opportunity



# ILD: Its Key Features

# The ILD Detector



- A major strength of the ILD detector is that it is BIG!
  - Large bore tracking volume, good  $BL^2$
  - Good separation between particles before they reach calorimeter
  - Adequate B-field

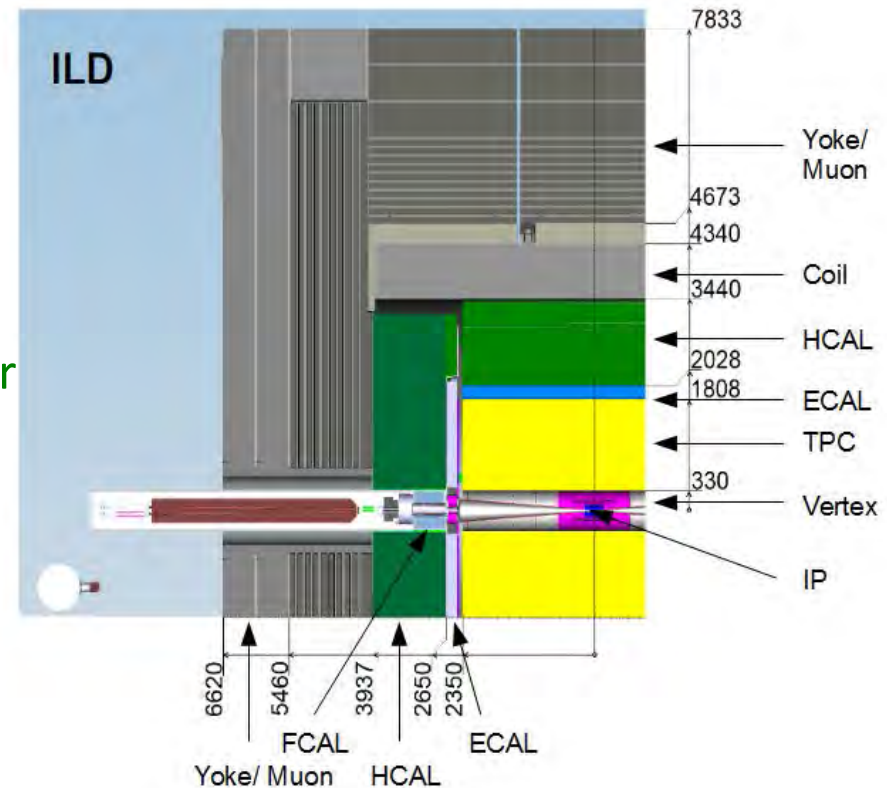
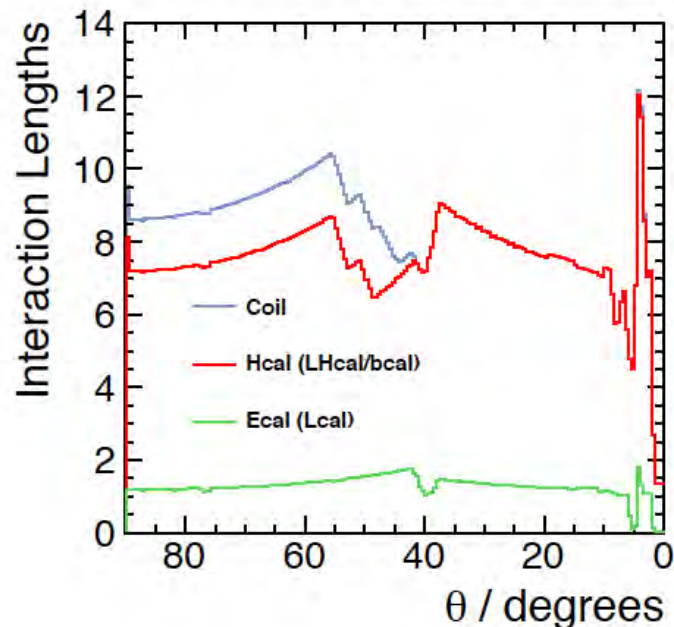

- Deep hadronic calorimeter with very good shower containment
- The size has a positive influence on many detector capabilities

# Calorimeter Performance

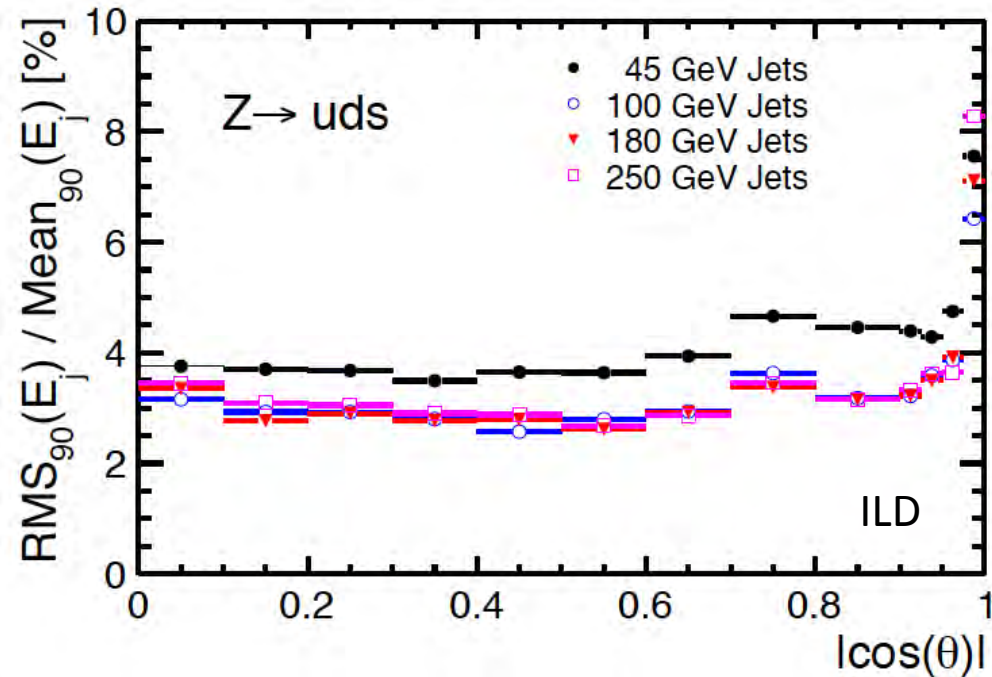
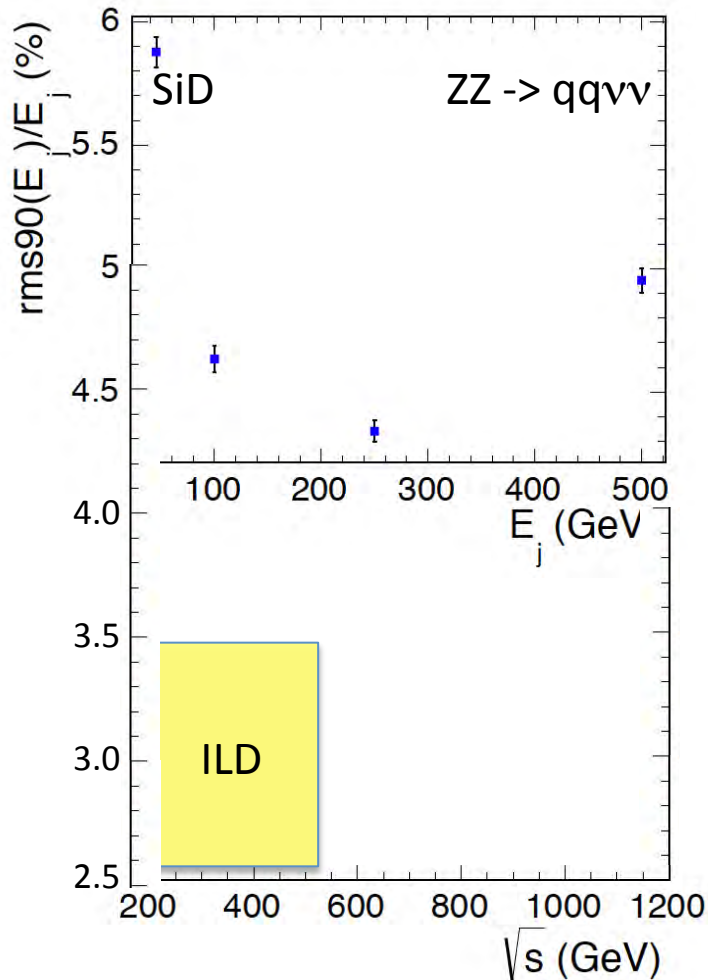

- The ILC goal is a jet energy resolution of about 3% over all jet energies
- The ILC detector meets this goal over all relevant jet energies and over the full angular coverage
- The performance of ILC is  $\sim$  30% better than SiD

# The ILD TPC



- ❑ A weakness of the ILD detector is the TPC
- ❑ The technology is intrinsically limited
  - Diffusion can only be mitigated, not eliminated
  - Resolutions – point and 2-hit – are modest
  - Integration over many bunch crossings
  - Space charge build-up in active volume
- ❑ The advantages of the technology do not translate into a unique physics performance advantage;
  - Asymptotic momentum resolution about the same as for SiD ( $2 \cdot 10^{-5}$ )
  - Low momentum resolution better ( $1 \cdot 10^{-3}$ )

$$\sigma(1/p_T) = 2 \times 10^{-5} \oplus 1 \times 10^{-3} / p_T \sin \vartheta$$

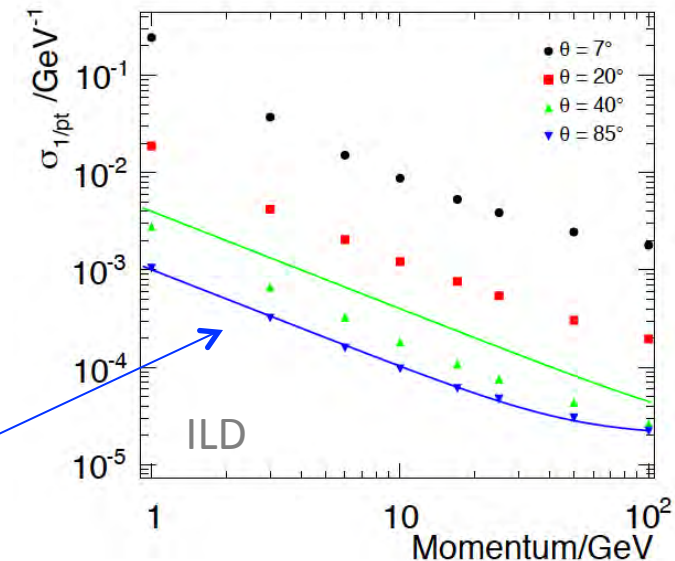
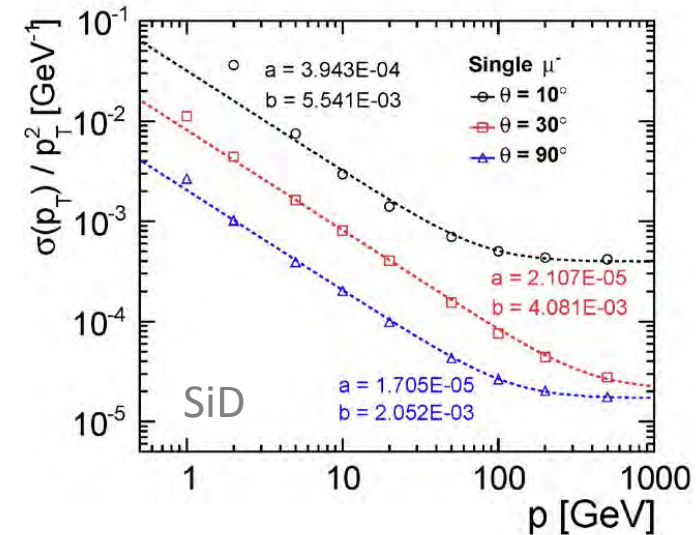



# The Silicon Envelope



- The silicon envelope consists of three, relatively major, subsystems:
  - **SIT**: two double layers of silicon before the TPC providing two 3d space points
  - **SET**: one double layer of silicon before the ECAL
  - **ETD**: one double layer of silicon before the endcap ECAL

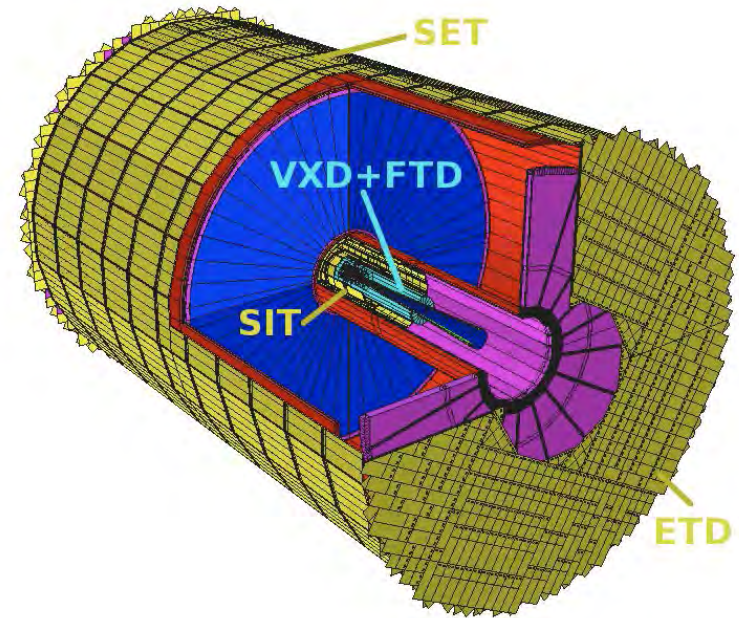

- It is not obvious that the Silicon Envelope enhances the tracking performance of the TPC; rather, the TPC requires the central silicon envelope
  - Timing, alignment and calibration
- Although the SIT is reasonably well motivated, the need for the SET and EDT has not been demonstrated

- ❑ The ILD argument seems to be weak:
  - TPC for robustness and efficiency
  - Silicon for ultimate resolution and vertexing
- ❑ The need for continuous tracking has not been meaningfully substantiated by physics analyses or detector performance
- ❑ Pattern recognition and track reconstruction can be done as well with more advanced technologies in even denser environments (ATLAS, CMS, ALICE), which allow for a more integrated approach to the detector design.

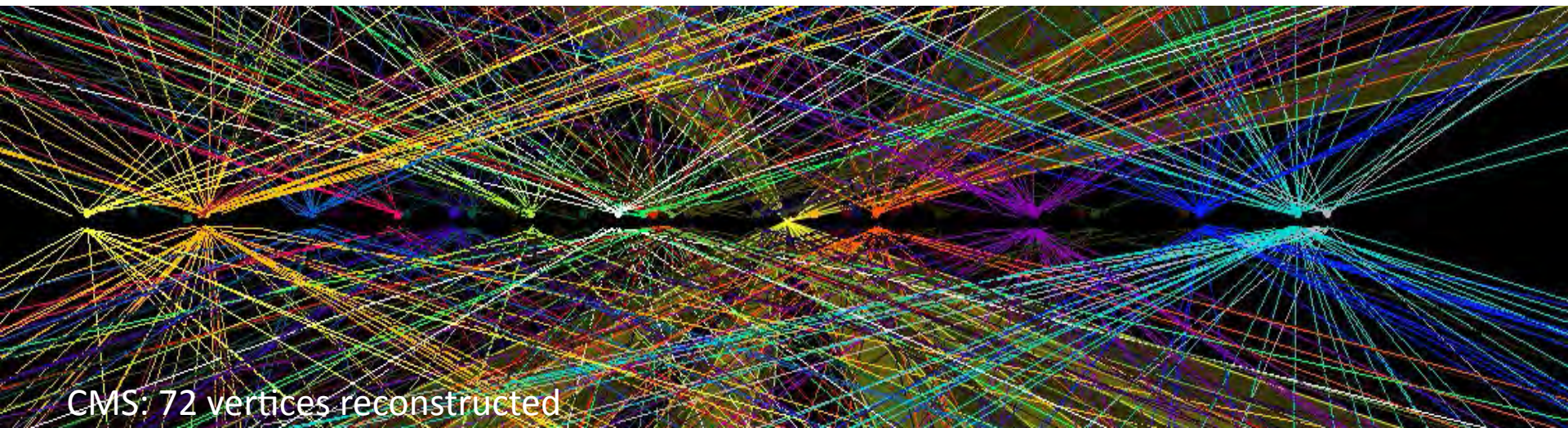

CMS: 72 vertices reconstructed

# The ILD Detector



- ❑ On the very positive side, ILD has been fairly aggressive in designing a most comprehensive ILC detector that is very performant.

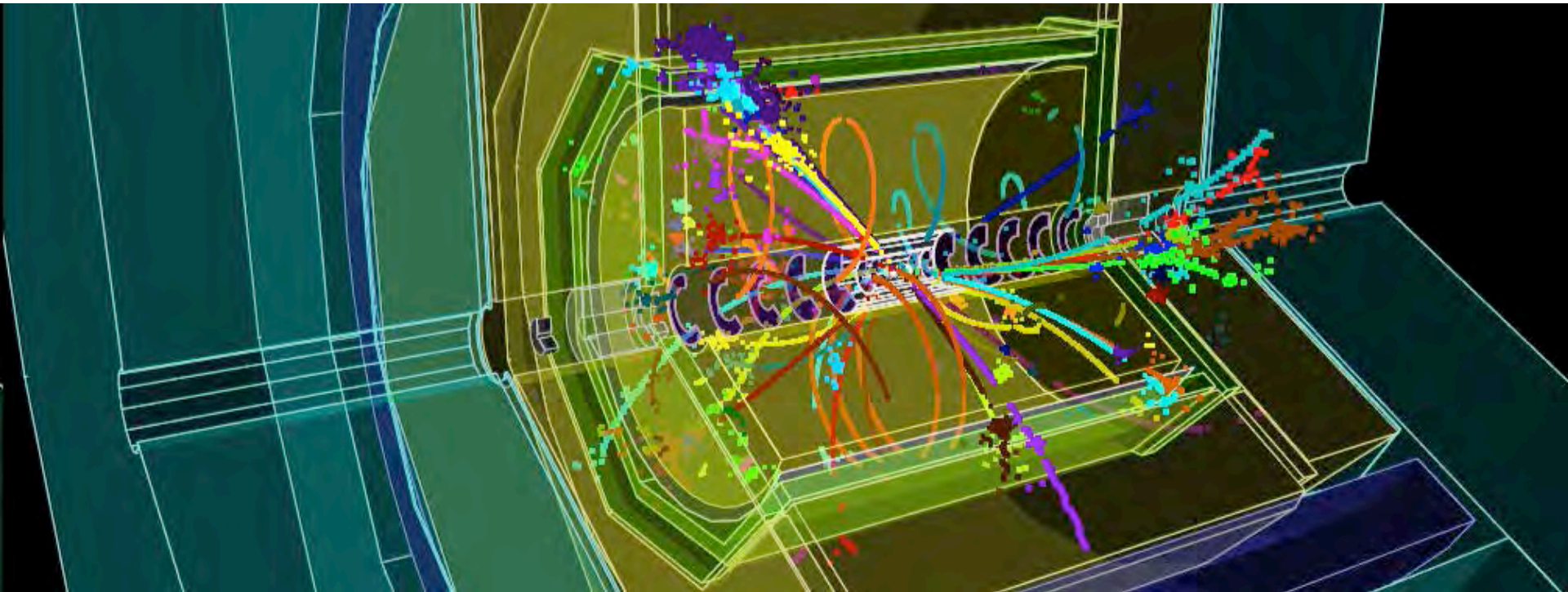

- ❑ On the negative side, the detector resorts to the use of multiple technologies to overcome the shortcomings of main technologies.



# Detector R&D

# Horizontal R&D Collaborations and ILD



- Strength: ILD is (nearly) completely embedded in the horizontal R&D collaborations

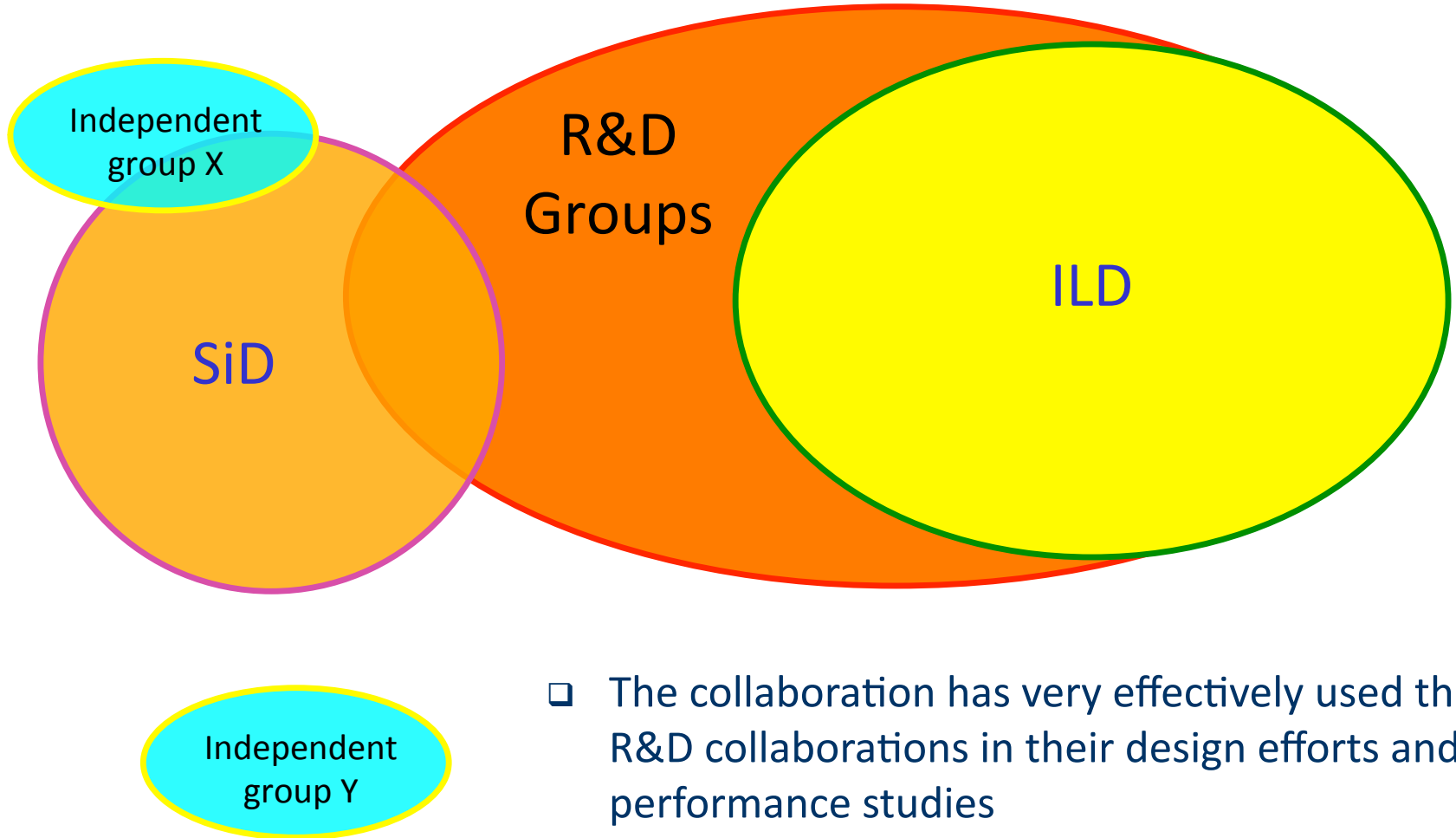

- The collaboration has very effectively used the R&D collaborations in their design efforts and performance studies



## GEM

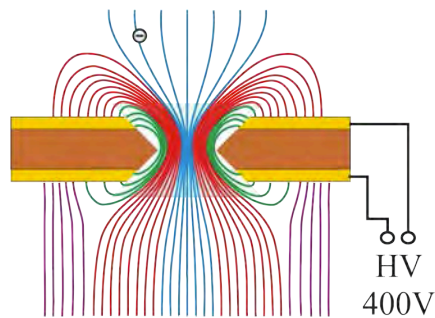

## MicroMegas

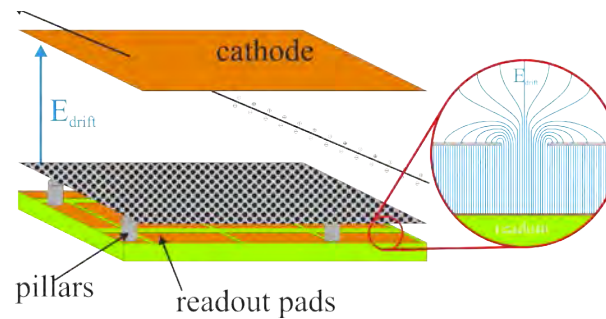

## InGrid

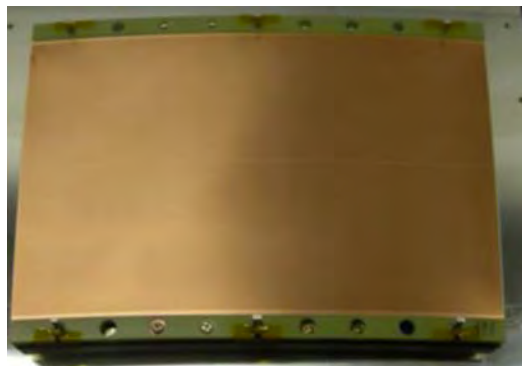
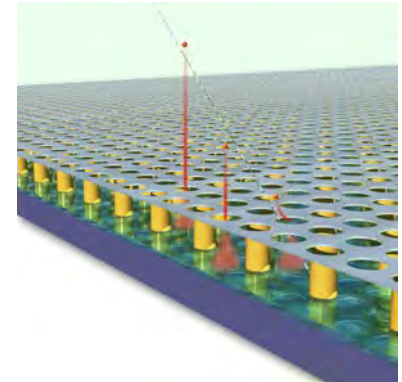

Two variants:  
Asian and German

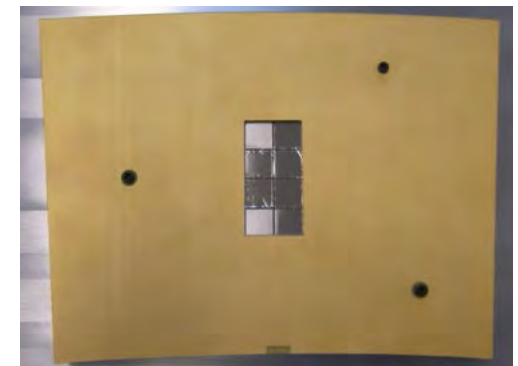

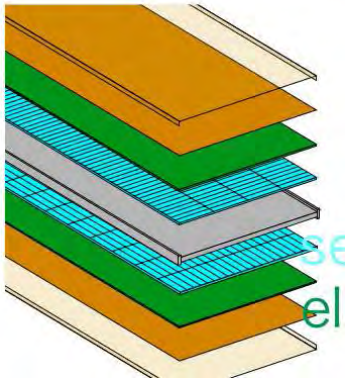

Sc/W-ECAL



Si/W-ECAL

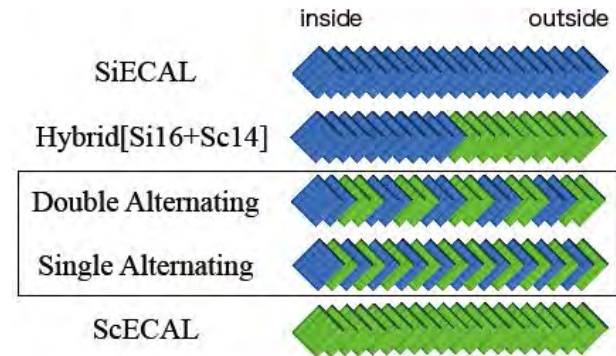

Si/Sc-ECAL

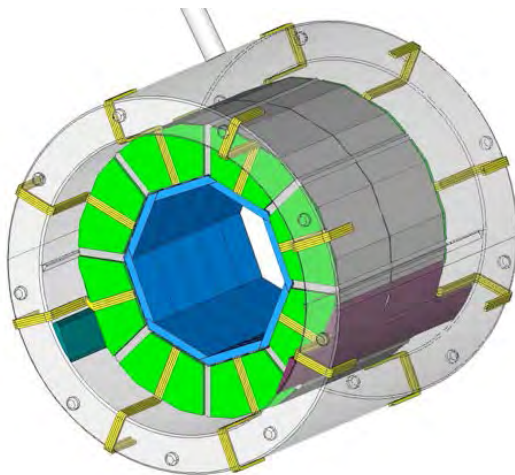

Sc-AHCAL

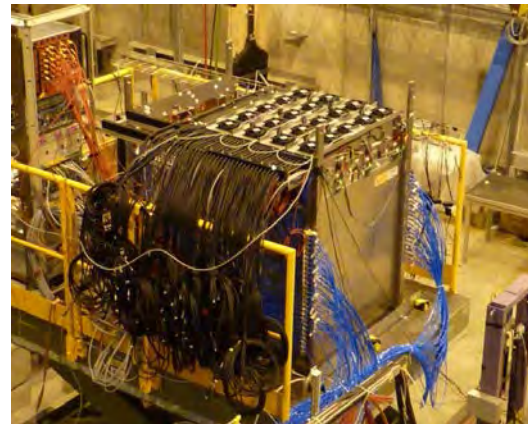

GRPC-SDHCAL

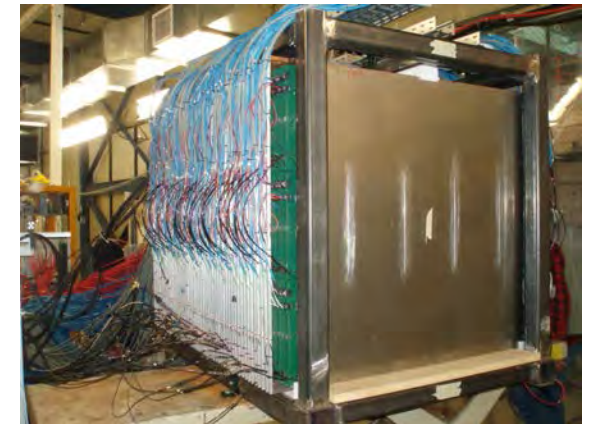

GRPC-DHCAL

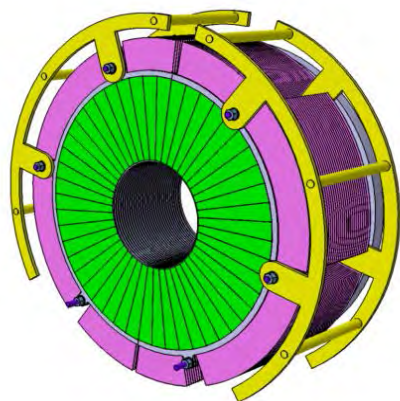

Lumi-CAL

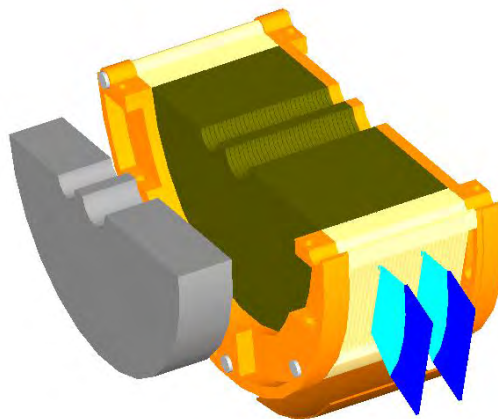

Beam-CAL

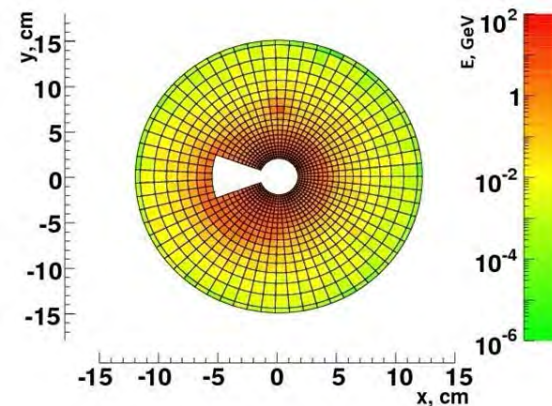

Physics Analyses

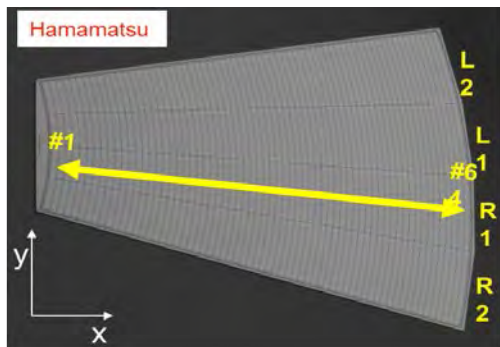

Sensors

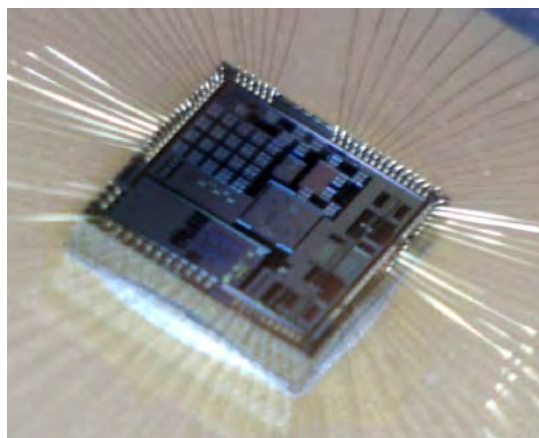

Readout - ASIC

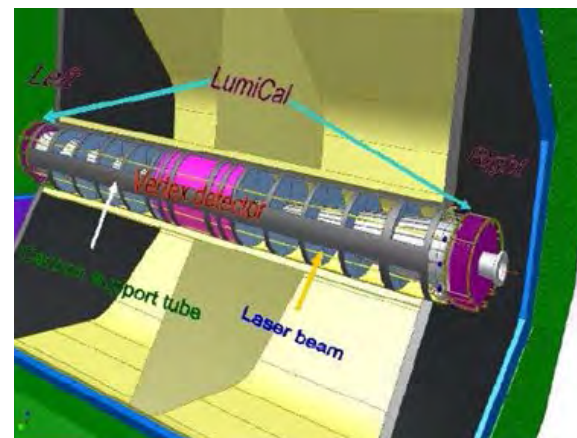

Alignment



# Silicon Tracking R&D, partly in SILC

SKIP

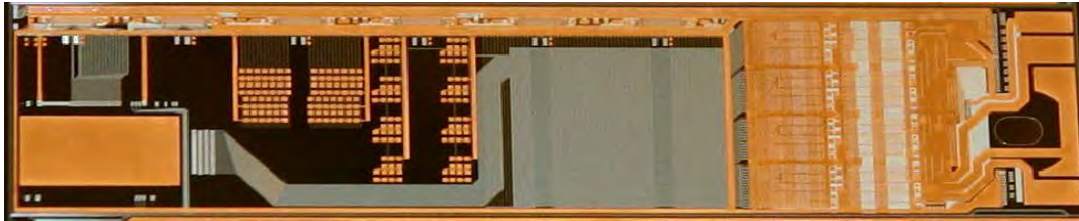

DEP-FET

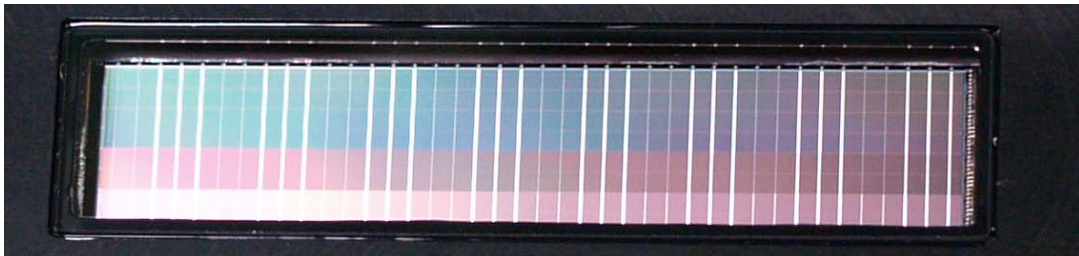

FP-CCD



CMOS Pixels



Mechanical Design

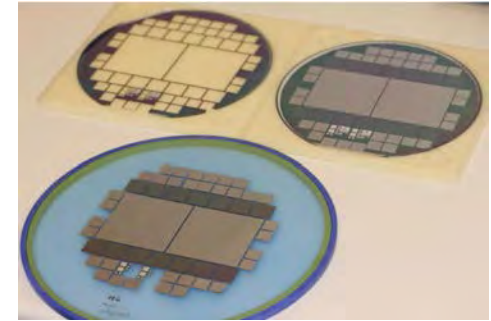

Edgeless Strips

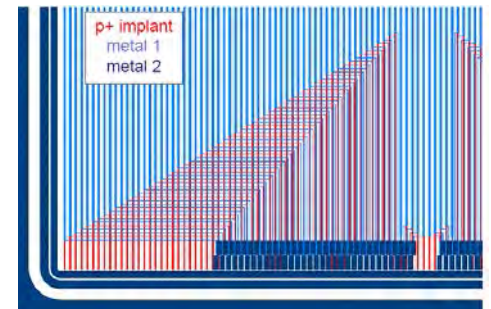

Hybrid-less Strips

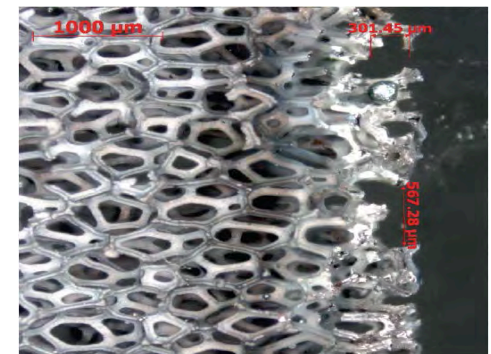

Low-mass materials

- ❑ A lot of very good and relevant R&D is being carried out both within the ILD collaboration and through the horizontal R&D collaborations
- ❑ Because ILD is nearly fully embedded in the horizontal R&D collaborations, direct access to the R&D and research sometimes directed towards ILD environment.

# Horizontal R&D Collaborations and ILD



- ❑ **Weakness:** ILD is (nearly) completely embedded in the horizontal R&D collaborations

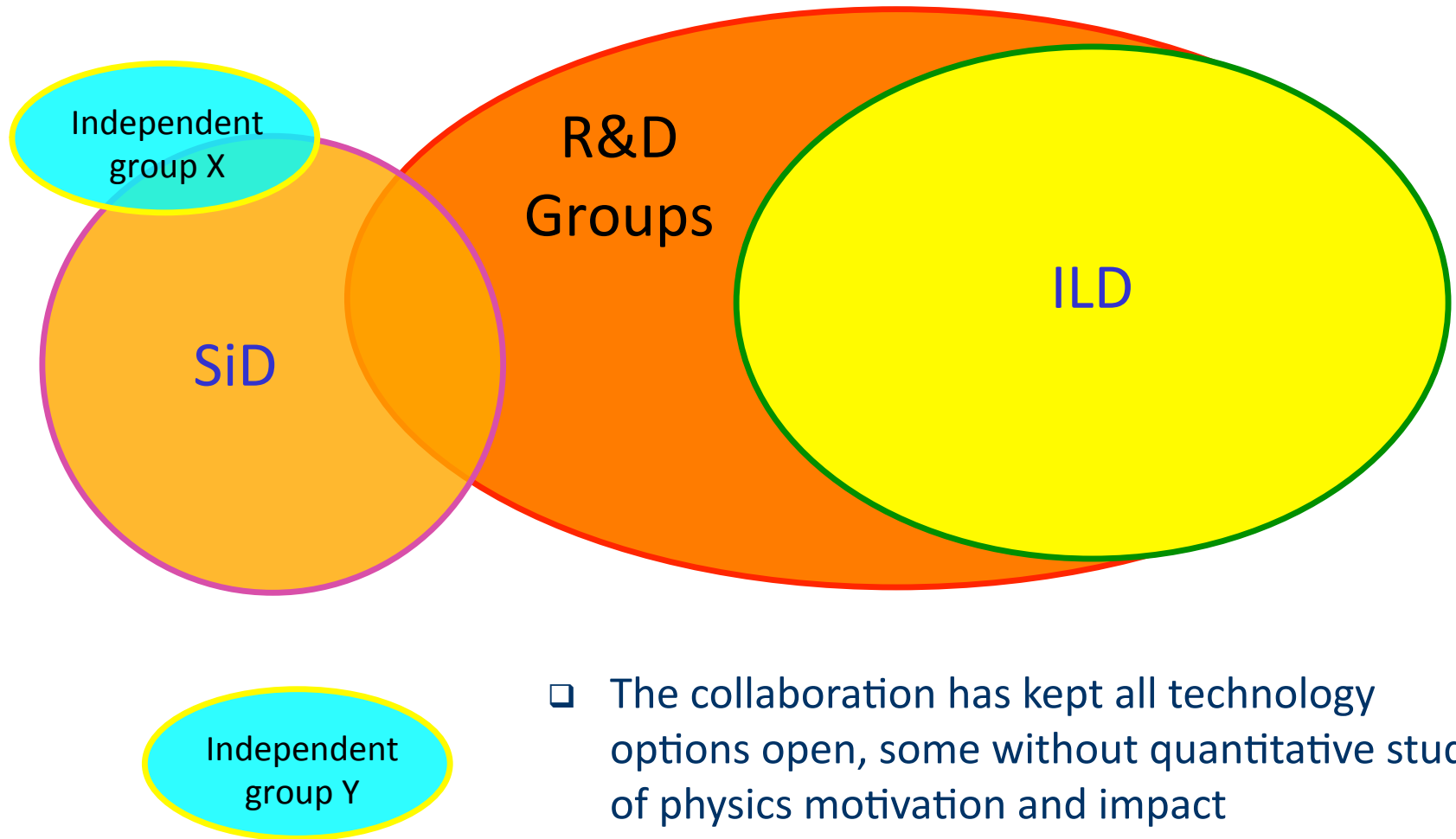

- ❑ The collaboration has kept all technology options open, some without quantitative study of physics motivation and impact

# Options and Alternatives

- Partly because of the tight coupling between ILD and the horizontal R&D collaborations, nearly all options and alternatives are kept.
- It is understandable that ILD would like to keep physicists in the collaboration, but it has led to “entrenched camps” within ILD and makes the collaboration fragile.
- Moreover, the connection to the physics reach and/or cost optimization of the various R&D efforts is not always existent.
- Moving forward, physics-based optimization of the detector both in terms of down-select of technologies and optimization within a certain technology should be the main driver.
- The collaboration would benefit from clear technology decisions over the next couple of years.



# Silicon Tracking System

- The silicon tracking system
  - VXD (barrel only; pixels)
  - FTD 2x2 inner disks (pixels)
  - FTD 2x5 outer disks (strips)
  - SIT: two double layers, strips
  - SET: one double layer, strips
  - EDT: one double layer, strips

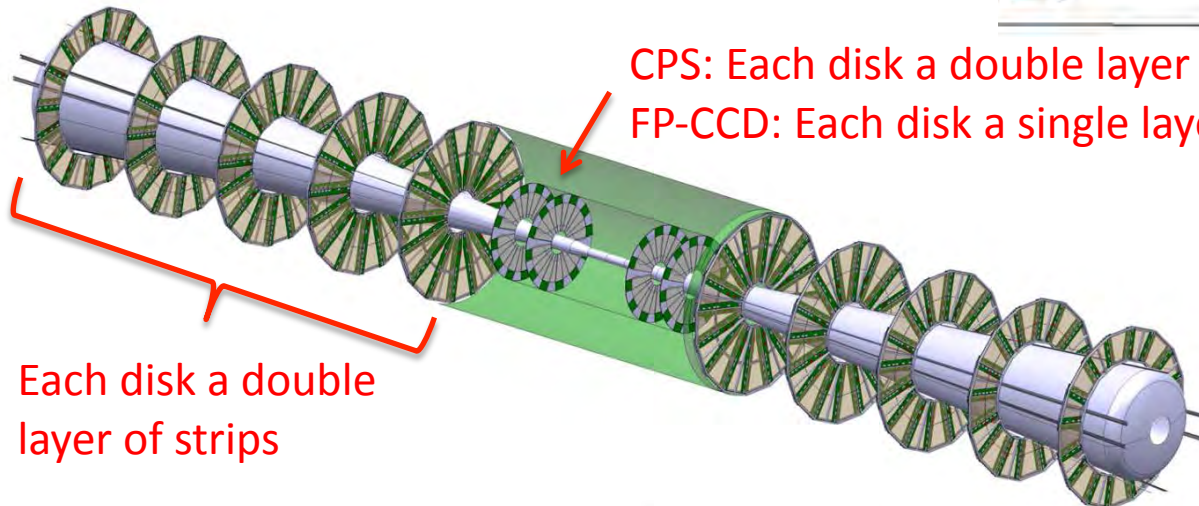
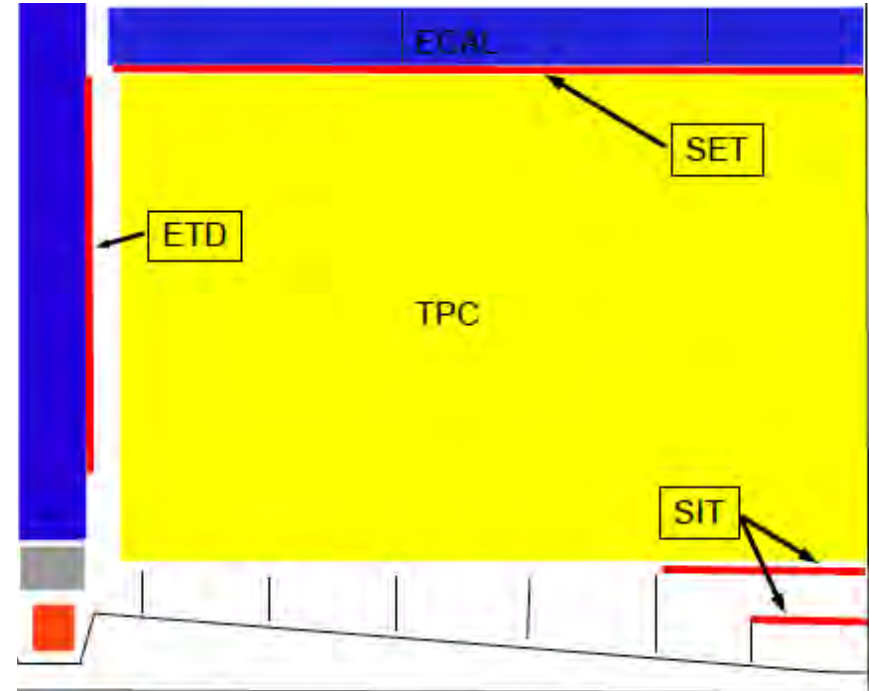

CPS: Each disk a double layer of pixels  
FP-CCD: Each disk a single layer of pixels

Each disk a double layer of strips

# Fragmentation

---



- ❑ Various systems seem to suffer some degree of fragmentation.
- ❑ An ILC detector is by definition an integrated detector and not a collection of subsystems
- ❑ However, the “entrenchment”, the multitude of technologies used and the plethora of options still being considered, prevents the collaboration from reaching its true full potential.
- ❑ Impression is that some technologies are being proposed for the sake of the technology without a consistent treatment and simulation to evaluate its effect on physics performance
  - e.g. FP-CCD in FTD without cryostat
  - e.g. Physics impact of double (versus single) layer of pixels per disk for two innermost disks of FTD
- ❑ When consolidating the design, the help of a project engineer who has good understanding of all subdetectors and installation issues would be extremely valuable



# Software

- ❑ The adoption of an Event Data Model and persistency framework, LCIO, common among the concepts, has been a great success (not just for ILD).

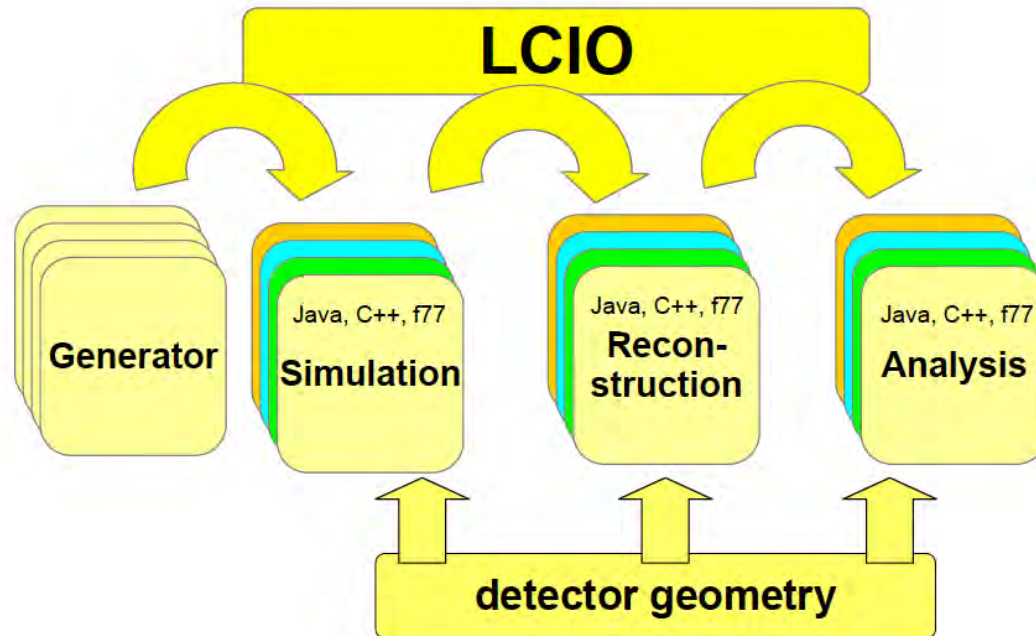

- ❑ Wonderful example of the strength of collaborative efforts



- Another great strength of ILD has been the development of the particle flow algorithm PANDORA within the collaboration.

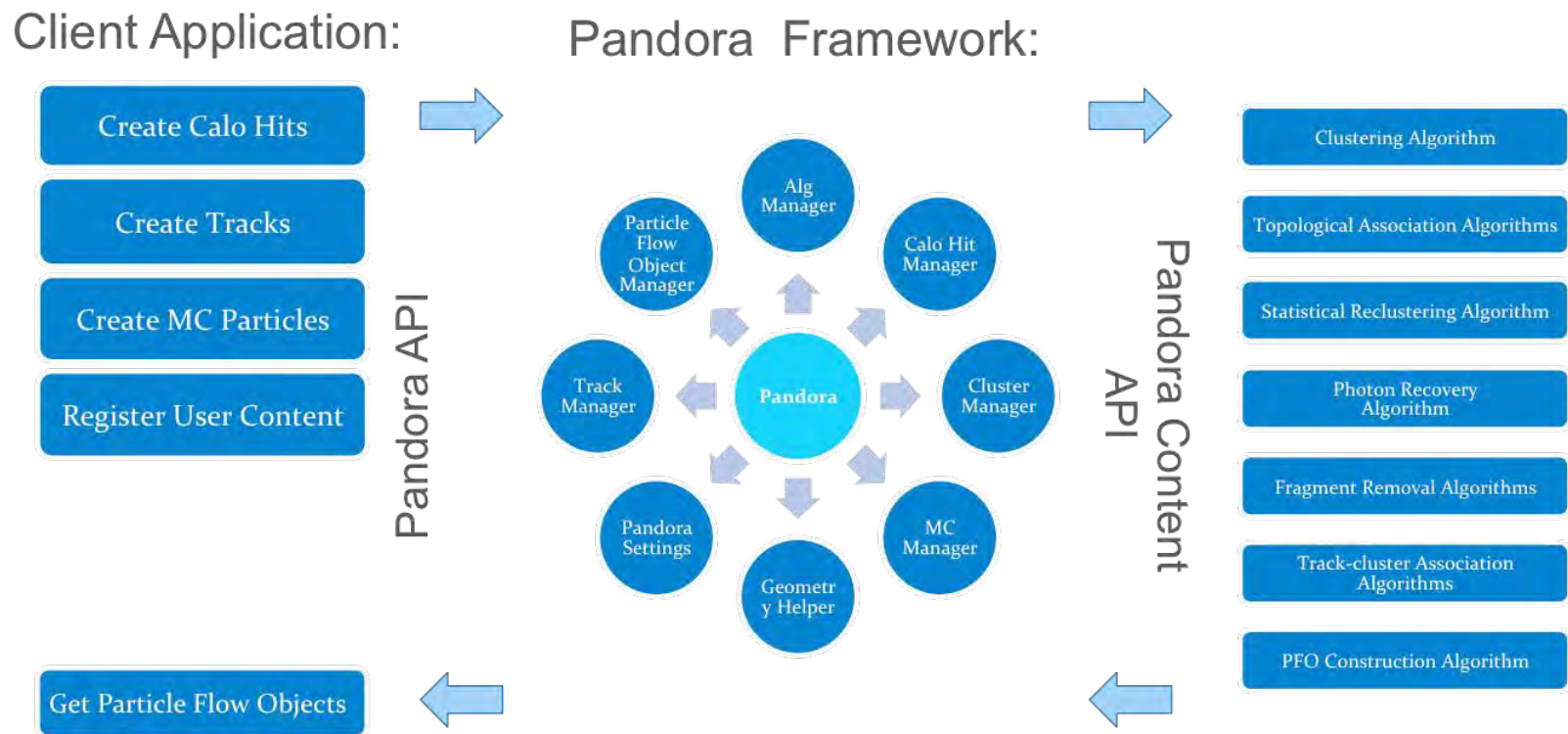

- The particle flow algorithm results have guided the development and optimization of the detector

- ❑ However, the ILD software situation is a bit precarious
- ❑ There are three major components in the ILD software chain
  - GEAR: GEometry Api for Reconstruction
  - MOKKA: Full event simulation using Geant4
  - MARLIN: Modular Analysis & Reconstruction for the LINear Collider
- ❑ Mokka is being phased out; timescale a bit uncertain

- ❑ A generic Detector Description toolkit, DD4hep, is being developed within the AIDA and Horizon2020 programs

- Detector description inspired by SLIC xml format

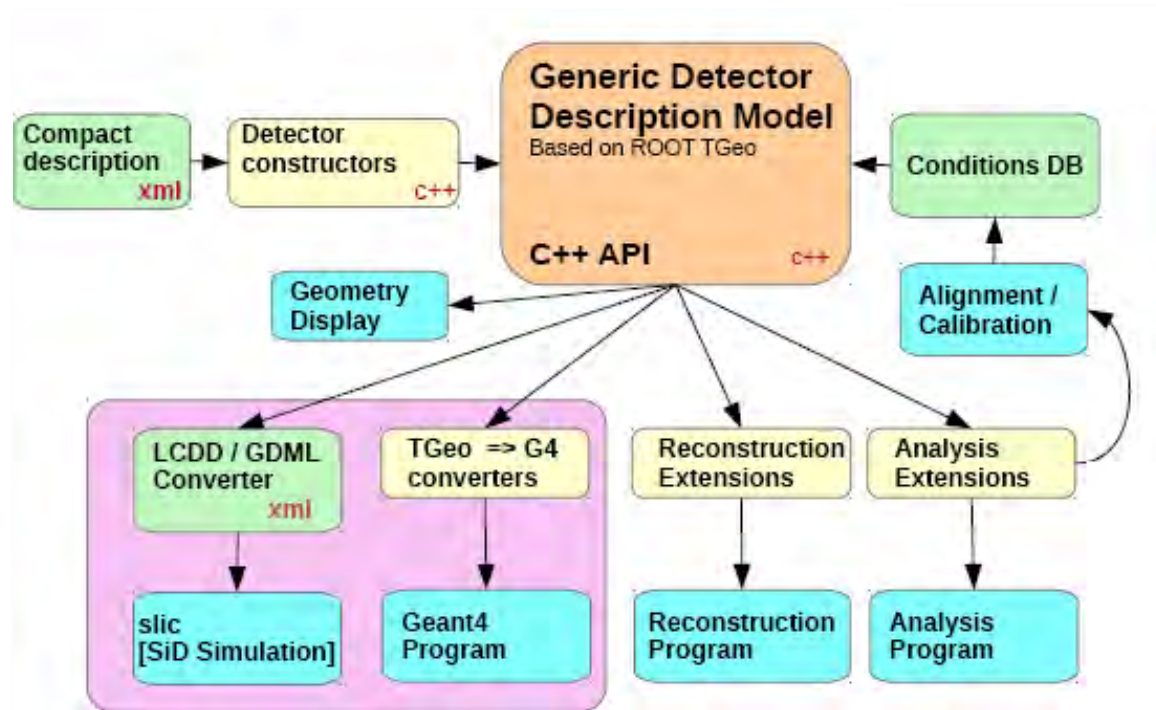

# DD4hep Development



- ❑ DD4hep is intended to be a detector software framework supporting the full experimental life cycle
- ❑ It is expected to provide a consistent description supporting: simulation, digitization, reconstruction, analysis and visualization
- ❑ Development led by CERN
  
- ❑ The further development of software tools and increasingly sharpen and strengthen the physics case for the ILC through simulations should, I believe, be of the highest priority
- ❑ The probability for adverse effects due to the development of a new software framework is high
- ❑ Careful coordination between the ILC, CLIC and FCC community is required to use this as an opportunity to strengthen the ILC software framework
- ❑ A common Event Data Format should be retained under any circumstance
- ❑ Note: SiD software support is subcritical and simulation effort for SiD should not be adversely affected

# Cost



- ❑ Cost constraint has up to now not been a significant driver for the ILD detector. In my opinion, that approach was a good approach.
- ❑ The priority of the ILC is to: demonstrate exceptional physics performance and reach based on modest extrapolation of technologies
- ❑ Now that the physics reach has been demonstrated, ILD would benefit from being more cognizant of the cost and its implications

- ❑ Efforts on cost control should now be undertaken through:
  - Overall detector optimization with focus on cost-effective technologies
  - Downselect of technologies
  - Identification of R&D paths to alternative, more cost-effective technologies that provide significant increase in sensitivity

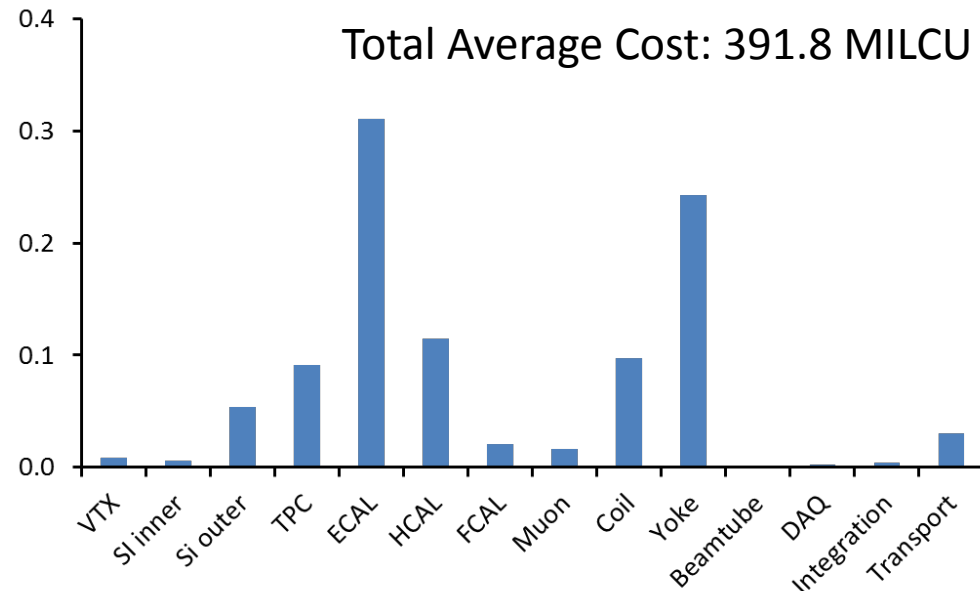

# Benchmark Analyses and Optimization



# Benchmark Analyses



- ❑ Thee detector models have been simulation for analyses
  - ILD\_o1\_v05: ILD with analogue HCAL and Si-ECAL
  - ILD\_o2\_v05: ILD with semi-digital HCAL + Si-ECAL
  - ILD\_o3\_v05: ILD with analogue HCAL + Sc-Strip-ECAL
- ❑ Excellent physics analyses both for the benchmark processes and beyond
- ❑ Collaboration has excellent publication record of most analysis, which is crucial for documenting the physics potential

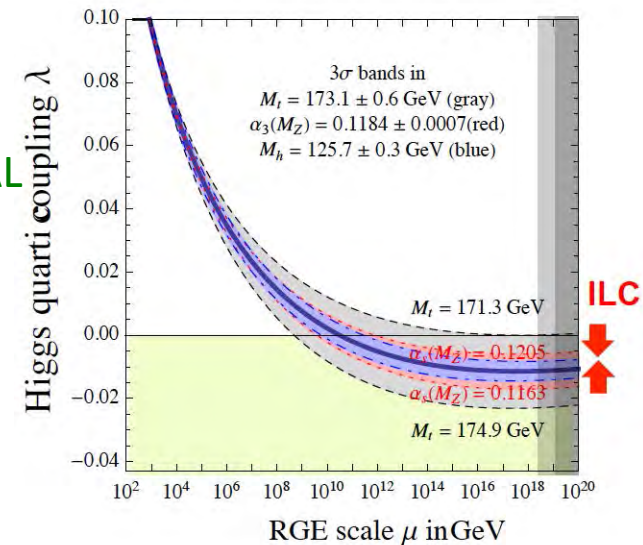

- ❑ Beam backgrounds are normally worse than considered, even in pessimistic scenarios.
- ❑ Some concern about the performance margin, especially of the vertex detector, for higher than expected backgrounds

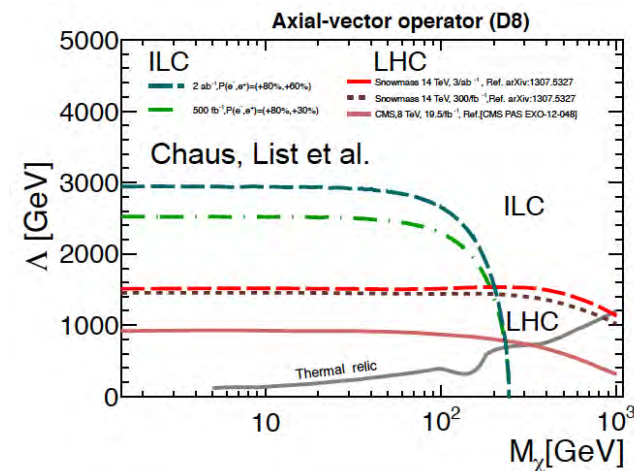

# Collaboration, Organization and Management





# Collaboration



- ❑ The ILD Collaboration is mainly constituted by European and Japanese institutions; within these regions some countries or institutions are quite strong
- ❑ The collaboration overall, though, is fragile. The ups and downs of the funding clearly have not helped building a stronger foundation; the collaboration may in fact have lost some momentum recently
- ❑ The pressures from other projects are beginning to be noticed.
- ❑ With the close collaboration and integration of the horizontal R&D collaborations, to an outsider it is sometimes not clear if members represent and speak for the horizontal R&D collaboration or for ILD
- ❑ It has also not always been clear what room there was for new contributions



# Organization



- The current public structure of ILD is publicized on <http://www.ilcild.org/org>

- Listed contact people for ILD:
  - Ties Behnke, Dean Karlen, Yasuhiro Sugimoto, Henri Videau, Graham Wilson, Hitoshi Yamamoto

## Contact people to the Research Director

|                    |   |
|--------------------|---|
| LOI Representative | Ties Behnke, Yasuhiro Sugimoto                      |
| MDI                | Karseten Buesser, Toshiaki Tauchi                   |
| Physics            | Klaus Desch, Keisuke Fujii                          |
| Software           | Frank Gaede, Akiya Miyamoto                         |
| Tools              | Catherine Clerc                                     |
| R&D                | Dhiman Chakraborty, Jan Timmermans, Tohru Takeshita |

## Working Group leaders:

|                       |                                  |
|-----------------------|----------------------------------|
| Detector Optimization | Mark Thomson, Tomohiko Tanabe    |
| Integration and MDI   | Karsten Buesser, Tauchi Toshiaki |
| Costing               | Tomoyuki Sanuki, Henri Videau    |
| Background            | Mark Thomson                     |

## Subdetector Contacts:

|                          |                                      |
|--------------------------|--------------------------------------|
| Vertex                   | Mark Winter, Yasuhiro Sugimoto       |
| SI-tracking              | Aurore Savoy-Navarro                 |
| Forward Silicon Tracking | Alberto Ruiz                         |
| TPC                      | Ron Settles, Takeshi Matsuda         |
| ECAL                     | Jean Claude Brient, Kiyomoto Kawagoe |
| HCAL                     | Imad Laktineh, Felix Sefkow          |
| FCAL                     | Wolfgang Lohmann                     |
| Muon                     | Vishnu Zutshi                        |
| DAQ                      | Guenter Eckerlin                     |
| Software                 | Frank Gaede, Akiya Miyamoto          |

# Organization



- ILD is in the process of restructuring; proposed bodies within ILD:
  - *ILD speaker*
  - *ILD Institute Assembly*
    - Decides on a set of central ILD rules
    - Decides the structure of ILD
    - Elects the ILD management
    - Endorses the formation of ILD working groups or other ILD bodies
    - 75% majority vote required; meets at least once a year.
  - *ILD management group*
  - *ILD detector coordinator*
  - *ILD physics coordinator*
  - *ILD Systems groups*
  - *ILD working groups*
  - *Operations Board*
- Structure seems a bit inflated for the stage of the project

# Organization



- ❑ ILD is in the process of restructuring; proposed bodies within ILD:
  - *ILD speaker*
  - *ILD Institute Assembly*
    - Decides on a set of central ILD rules
    - Decides the structure of ILD
    - Elects the ILD management
    - Endorses the formation of ILD working groups or other ILD bodies
    - 75% majority vote required; meets at least once a year.
  - *ILD management group*
  - *ILD detector coordinator*
  - *ILD physics coordinator*
  - *ILD Systems groups*
  - *ILD working groups*
  - *Operations Board*
- ❑ Structure seems a bit inflated for the stage of the project
- ❑ Where does the executive power reside? Who decides??



**On whose desk?**

# Organization

---



- ❑ **ILD is seen as lacking leadership.**
- ❑ After the LOI submission, ILD intended to restructure to a more efficient organization resembling a collaboration. This never happened
- ❑ ILD has two “speakers” who function as spokespeople but who have not been vested with the authority of a spokesperson
- ❑ As a consequence, response time is slow; decision taking process is unclear, decisions deferred
  
- ❑ There are, of course, good reasons for this. The ILC has not benefited from the support other projects have and the emphasis has been on growing a fragile community in a difficult financial environment.
  
- ❑ **How do we move forward as a community ?**





# **OUR** Challenge



- ❑ In my humble opinion, for the next two years the emphasis for the whole ILC community should be placed on sharpening as much as possible the physics case for the ILC along the three P5 science drivers in a coherent way:
  - Higgs as a new tool for discovery
  - Identify the new physics of dark matter
  - Explore the unknown
  
- ❑ What does that mean for ILD and for the ILC community?
- ❑ Allow me to suggest possible general approaches in the areas of:
  - Detector optimization
  - Physics Analyses and Software

# Detector Optimization



- ❑ Detector technology down-select should be done decisively and timely
  - Down-select should be physics driven, not technology driven; proponents are (should be) proponents of the ILC physics. If there is no ILC, then there is no chance for any technology
- ❑ Select the most performant technologies with an eye to cost
  - Cost will be a major consideration; better to face it sooner rather than later
  - The field of particle physics is under significant budgetary pressure:
    - Upgrades of LHCb, ALICE, Phase-II upgrades of ATLAS and CMS
    - LBNF, Hyper-K, JUNO, ...
    - PIP-II, FCC, CEPC, ..... (Tokyo Olympic Games 2020)
  - The cost differential within an experiment is small compared to the cost differential between one or two experiments!
- ❑ Extrapolation of currently aggressive R&D technologies should be encouraged: push technology limits to get better performance
  - Prototypes do not have to exist already in all areas
  - Look at what is going on elsewhere



# Challenge Ourselves More ?

- The ALICE experiment is developing a 1Gpixel, 7-layer MAPS-based silicon pixel detector, scheduled to be installed in 2018

ALICE Inner Tracker System,  
CMOS MAPS, 7 Layers  
25 Giga pixels!

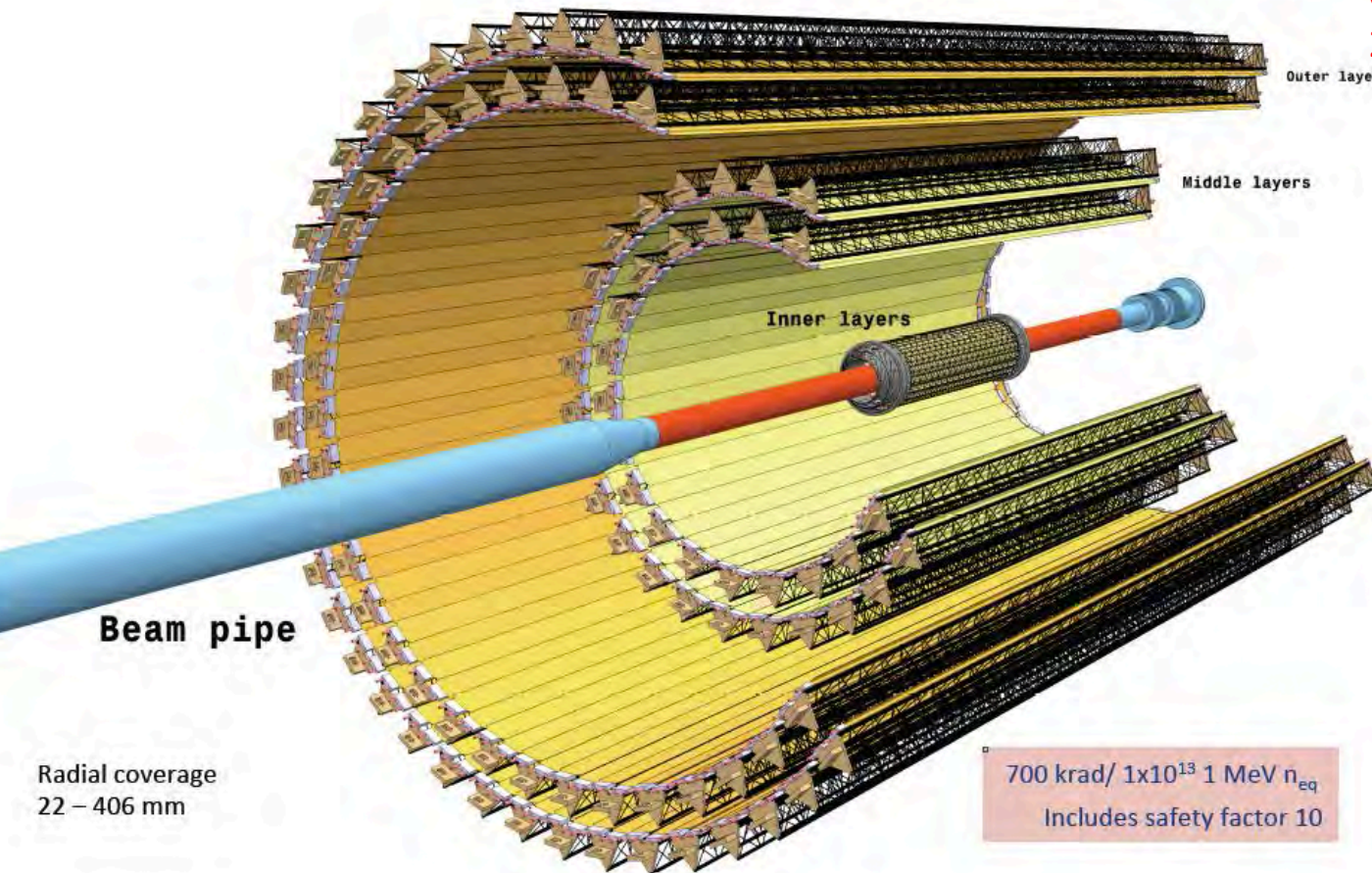

Radial coverage  
22 – 406 mm

700 krad/  $1 \times 10^{13}$  1 MeV  $n_{eq}$   
Includes safety factor 10

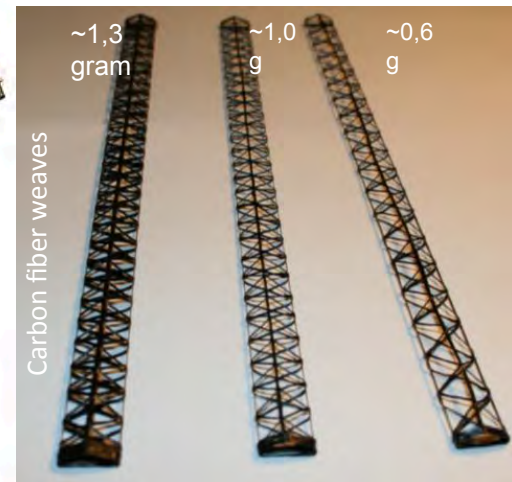

Taking data: 2018

# Challenge Ourselves More ?

- The ALICE upgrade calls for a set of five MAPS pixel disks in the forward region

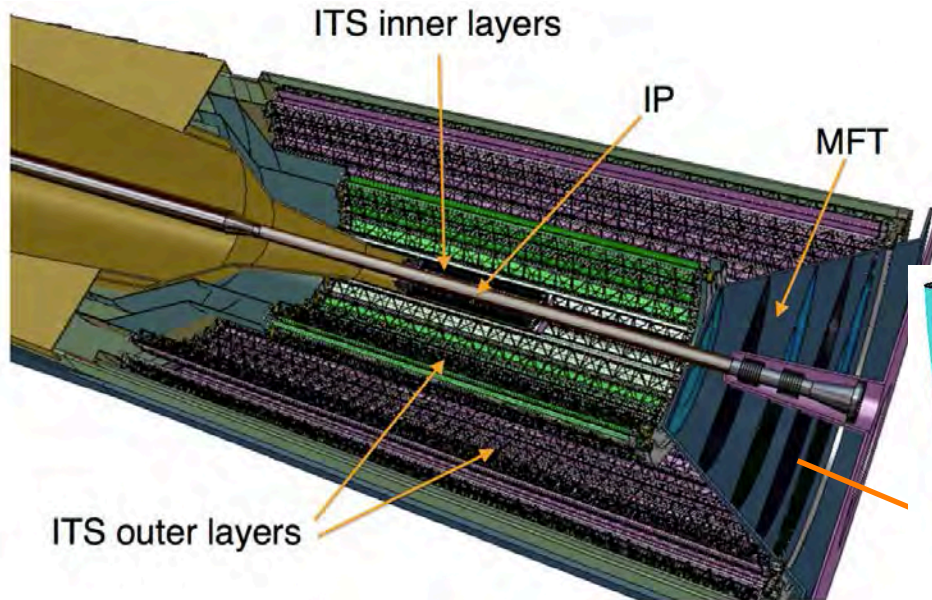

Taking data: 2018

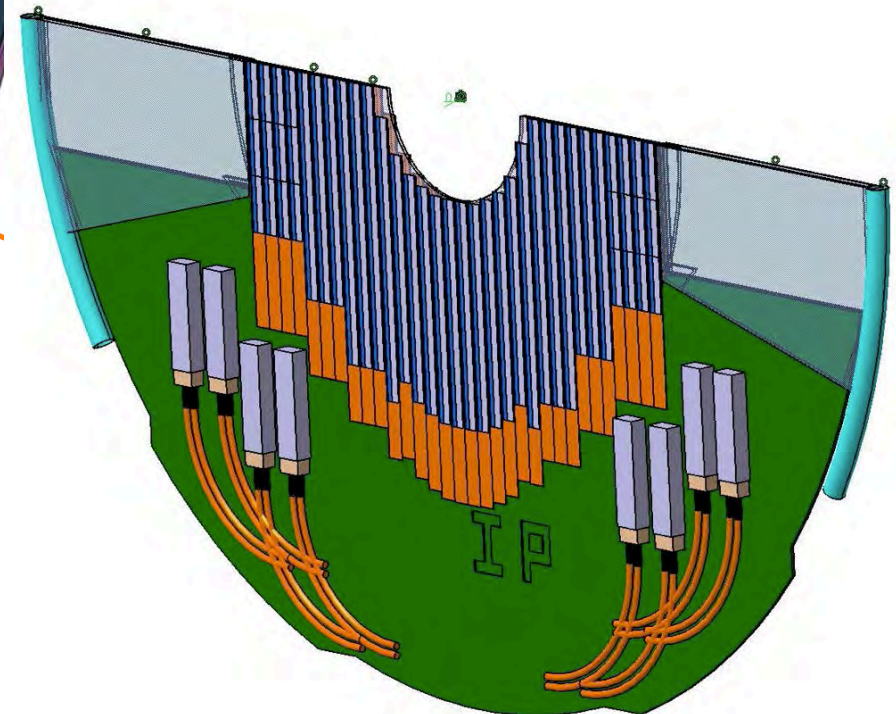

**ALICE Muon Forward Tracker**  
**Five disks of CMOS MAPS pixels**  
**25x25  $\mu\text{m}^2$**

# Exploit Synergies?

- ❑ The CMS experiment is looking to a fine grained Si calorimeter as an option for the Phase-II forward calorimeter (600 m<sup>2</sup> of Si)
- ❑ Electromagnetic Calorimeter:
  - 31 layers of lead/copper; 25 X<sub>0</sub>
  - 420 m<sup>2</sup> of Si, 3.7M channels.
- ❑ Front Hadronic Calorimeter
  - 12 layers of brass; 4 λ
  - 150 m<sup>2</sup>, 1.4M channels

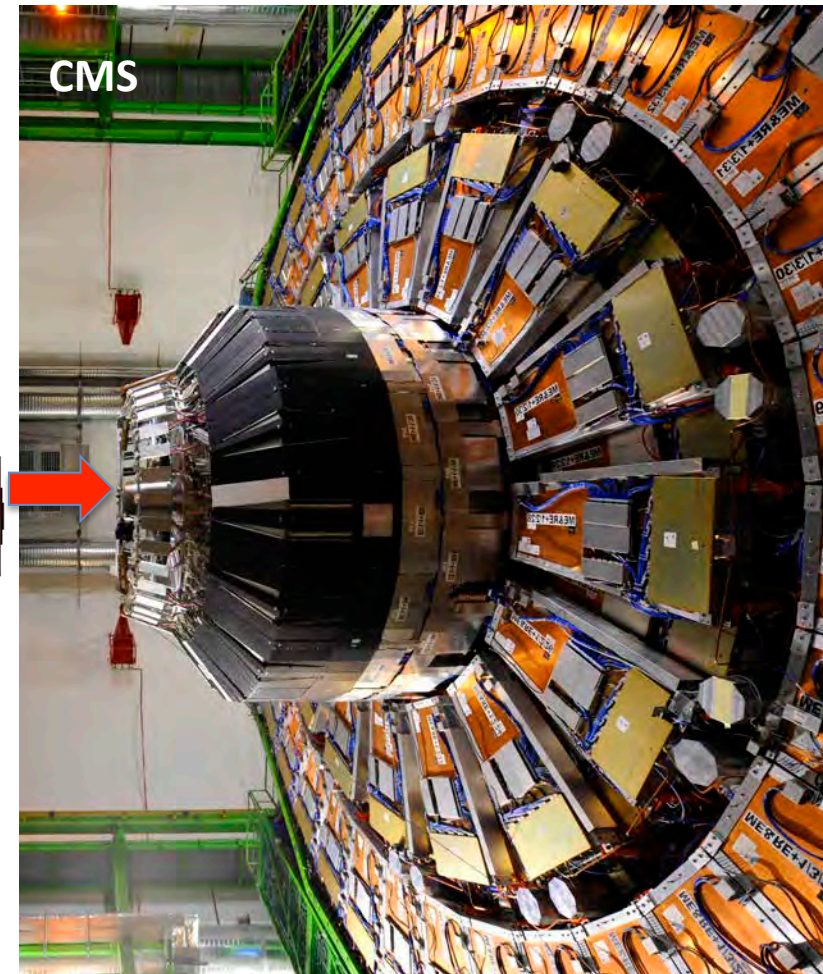
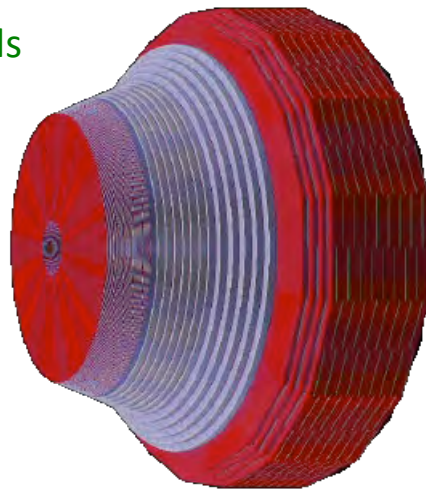
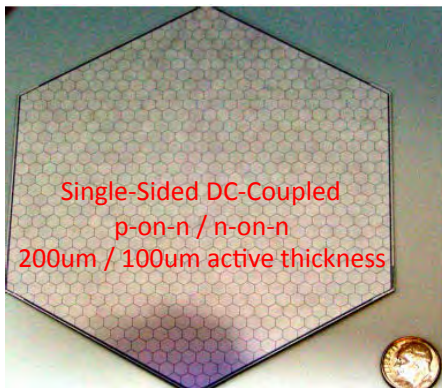

# Physics Analyses



- ❑ Excellent analyses of the Higgs sector and SUSY indicating the potential of the ILC
- ❑ This is most likely not sufficient for a project of this scale
- ❑ A complete, but comprehensive picture of the full physics potential of the ILC should be put together addressing the big questions
  - **Higgs as a new tool for discovery**
  - **New physics of dark matter**
  - **Know the unknown**
    - **Little Higgs, composite Higgs**
    - **Hidden valleys**
    - **Randall-Sundrum, Kaluza-Klein**
    - **GUTs, composite top**
    - ...
  - **And how it complements projects such as g-2, COMET, LHC, ...**

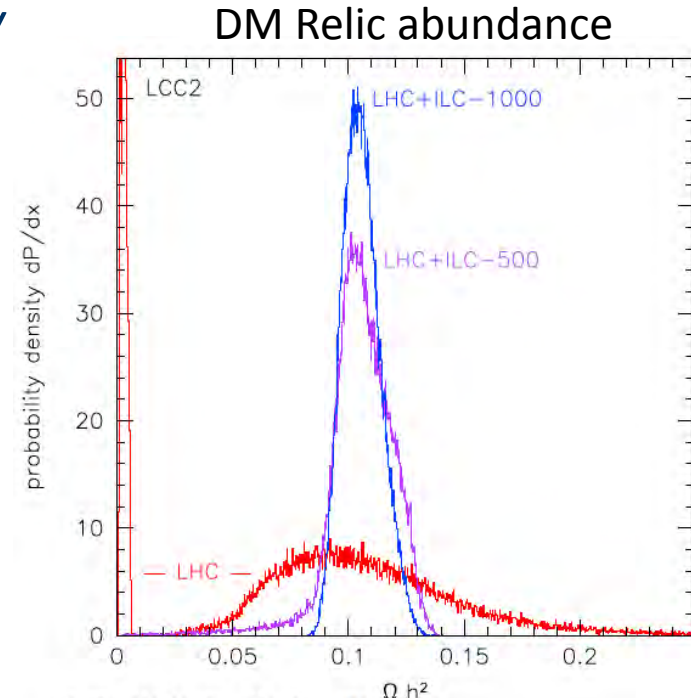

Baltz, Battaglia, Peskin, Wizansky  
PRD74 (2006) 103521, arXiv:hep-ph/0602187

# Advanced Physics Analyses



- To date there has been very little in advanced analyses of jet charge and vertex charge.

$$Q = \frac{\sum_j p_j^k Q_j}{\sum_j p_j^k}$$

- There is tremendous power in heavy flavor physics, especially combined with polarization and discrimination of b- and c-quarks, such as  $A_{FB}$

- It would be great to extend the physics analyses to this degree of sophistication showing that the ILC will provide many independent, deep probes for new physics

- What will be the ILC legacy plots ?

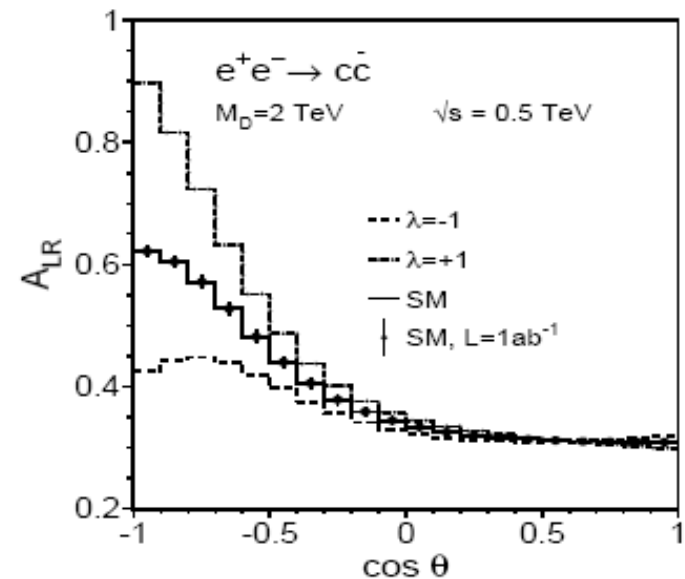
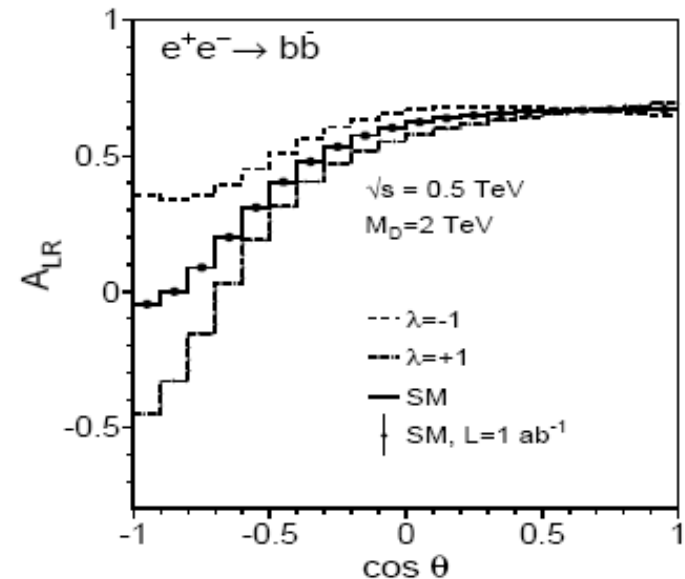

# Software



- ❑ The optimization of the ILD and SiD detector and the advancement of physics analysis relies completely on the software and the analysis tools.
- ❑ It is critical in the transition from Mokka to dd4hep to retain all the simulation and analysis capabilities at all times
- ❑ The support from the CLICdp group should be sought aggressively in support of ILC software development and physics analyses.

# Balance



- ❑ **The ILC project is in critical balance !**
- ❑ On one hand, Japan is setting very high standards for approval of the ILC project through a protracted process
- ❑ On the other hand, the ILC detector communities are shrinking
  - Pressure on ILD from Europe
  - DOE does not provided any ILC support despite the P5 recommendation
  - The SiD effort is falling below critical mass
  
- ❑ Ironically, the strongest group might be the CLICdp group
- ❑ It is critical that resources of SiD, ILD and CLICdp be pooled towards the common goal of meeting the MEXT requirements for the ILC project



- Japanese institutions that are member of the ATLAS experiment: 16
  - Hiroshima Institute of Technology, Hiroshima
  - KEK, High Energy Accelerator Research Organisation, Tsukuba
  - Kobe University, Kobe
  - Department of Physics, Kyoto University, Kyoto
  - Kyoto University of Education, Kyoto
  - Kyushu University, Kyushu
  - Nagasaki Institute of Applied Science, Nagasaki
  - Nagoya University, Nagoya
  - Faculty of Science, Okayama University, Okayama
  - Osaka University, Osaka
  - Faculty of Science, Shinshu University, Matsumoto
  - International Centre for Elementary Particle Physics and Department of Physics, the University of Tokyo, Tokyo
  - Tokyo Institute of Technology, Tokyo
  - Physics Department, Tokyo Metropolitan University, Tokyo
  - Institute of Physics, University of Tsukuba, Tsukuba
  - Waseda University, Tokyo
- Japanese Institutes (in addition to ones in orange above) participating in this meeting:
  - Kinki University
  - Nippon Dental University
  - Saga University
  - Sokendai, Tsukuba
  - Tohoku University
  - University of Tokyo

Is the fact that not all Japanese universities with vested interest in particle physics are not participating in ILC discussions of concern?



# Conclusion



- ❑ ILD is a potent ILC detector concept and a strong ILC collaboration that has made huge contributions to making the case for the ILC
- ❑ It has many strengths and some weaknesses, which can be easily addressed.
- ❑ **The next two years will be crucial. It is now or never. ILD is in the best position to take the lead in making the ILC a reality. It should do so!**
- ❑ It will require the close collaboration of SiD, ILD, CLICdp, with strong support from the LCC Physics and Detector Group. Let's work together to make it happen!



# Backup

---



# ILC Timeline

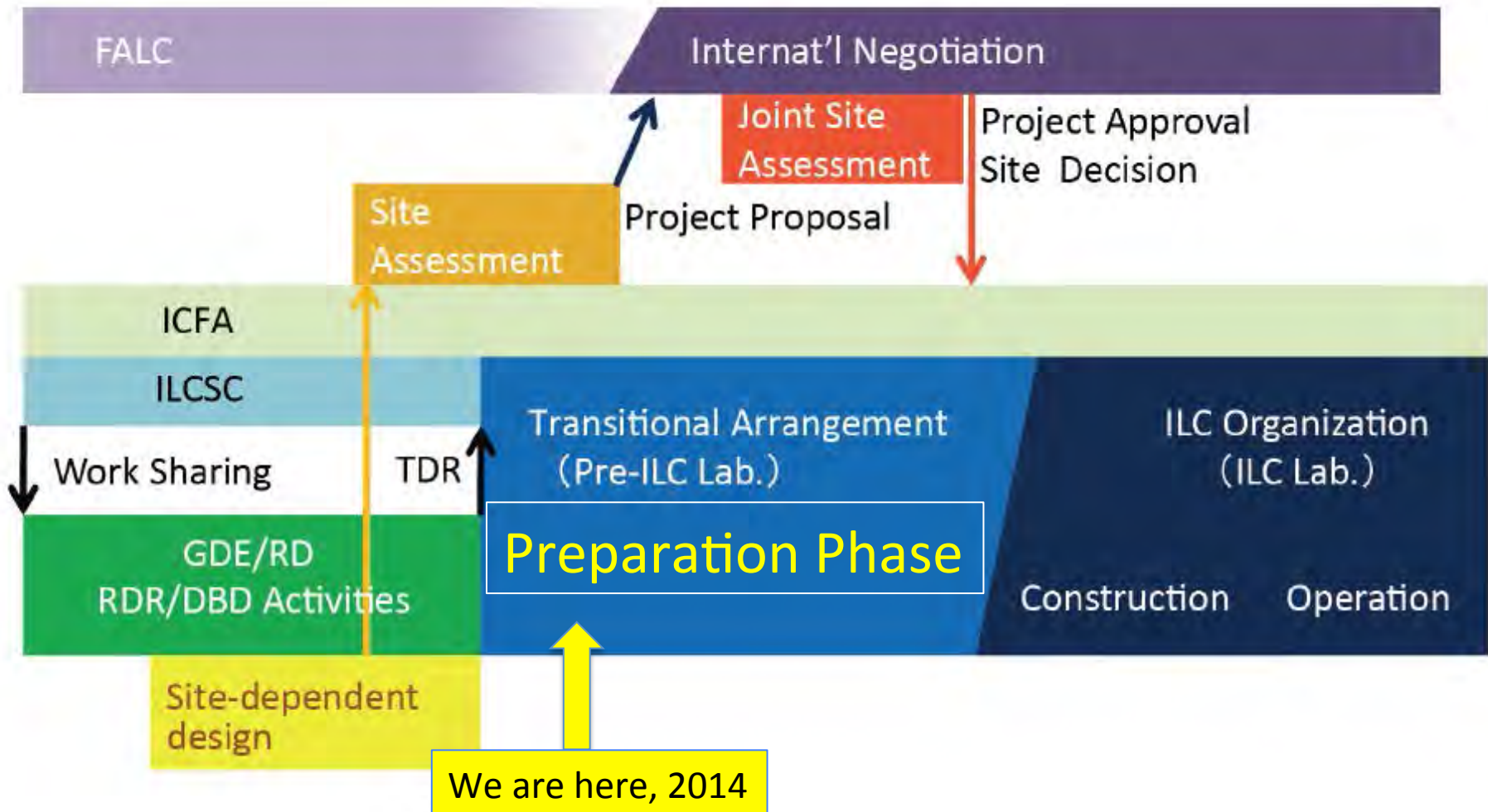

- ❑ Japan will decide to move ahead with the ILC around the start of the Japanese fiscal year 2016.

# Perspective



- ❑ Next steps in the Energy Frontier – Hadron Colliders, Workshop at the LHC Physics Center @ FNAL
  - 83 participants, 13 non-US
- ❑ SiD workshop in Japan, Sept 2-3, 2014
  - 32 participants, 19 from Japan
- ❑ This ILD workshop
  - 85 participants, 47 from Japan

