

SiD Tracker Geometry

Tim Nelson - SLAC

ALCPG Snowmass, CO

8/16/2005



Overview

- ❏ **Develop detailed material model from baseline SiD tracker design**
- ❏ **Translate to org.lcsim compact geometry definition format**
- ❏ **Develop models for alternate designs**
- ❏ **Make these geometry models for usable for physics studies**
- ❏ **Generate ideas for next level of refinement**



Baseline SiD Tracker Design

- ❏ **Closed CF/Rohacell composite cylinders**
- ❏ **Nested support via annular CF rings**
- ❏ **Power/readout distribution mounted on support rings***

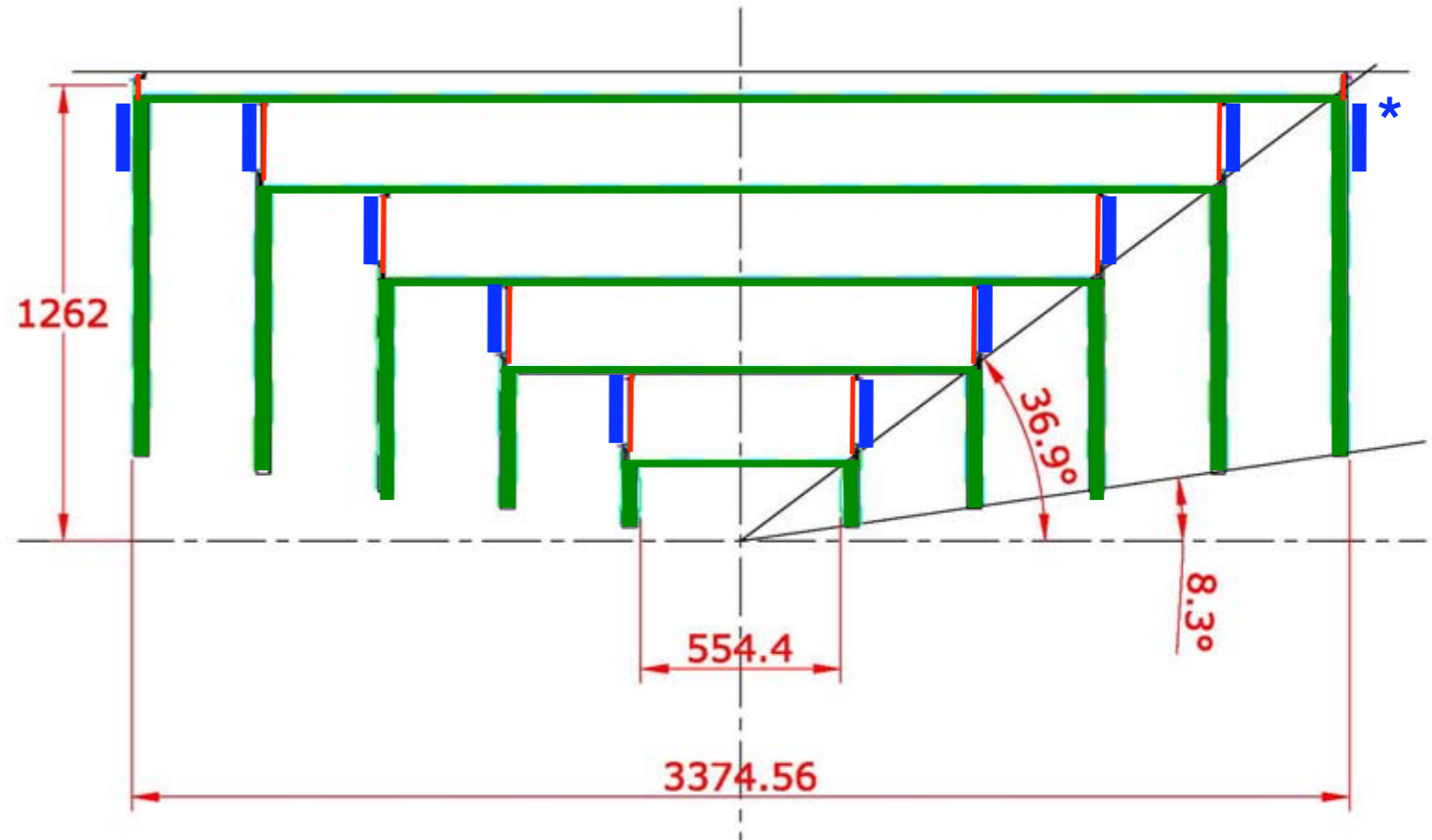

Baseline SiD Tracker Design

Outer surfaces of cylinders tiled with small (~10cm×10cm), low-mass, sensor modules

single-sided in barrel (r-φ)

double-sided in disks (??)

Modules are primarily silicon with minimal support. Readout material minimized.

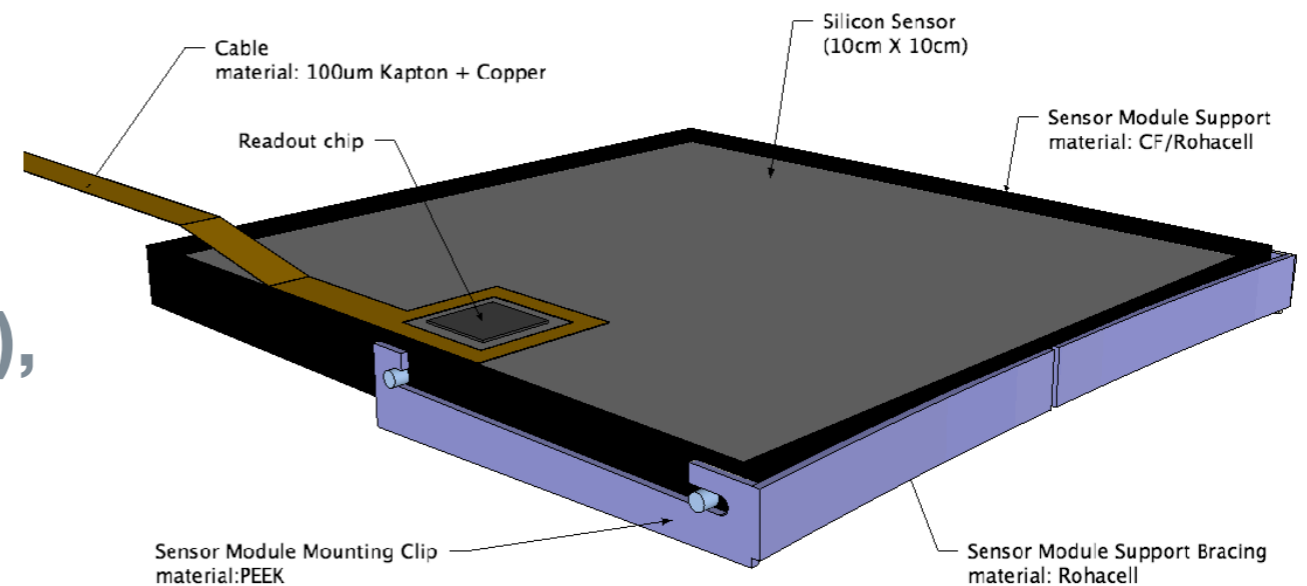

X0/Unit Coverage (%) for Barrels with Short Silicon Modules

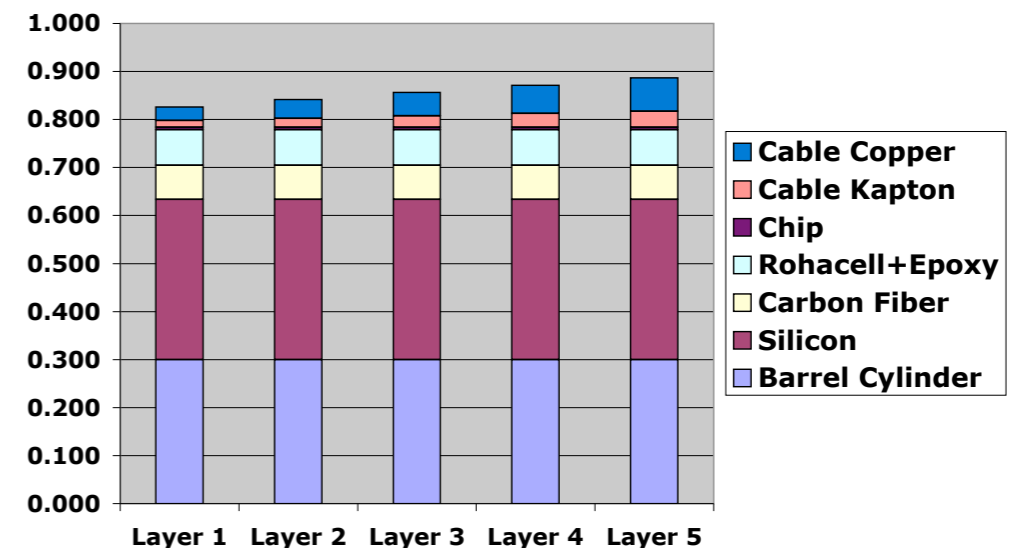

Baseline SiD Tracker Design

http://confluence.slac.stanford.edu/download/attachments/4292/SiD_material.pdf

❖ A description of this material is catalogued in a simple document

❖ “peanut-butter” model

SiD Tracker Material
V0.23

Tim Nelson

July 15, 2005

1 Introduction

This document describes the current understanding of material necessary for an ILC tracking detector based on the SiD detector concept and utilizing short silicon readout modules. While no description of detector material is ever complete or perfectly precise, a reasonable model of this material is necessary to estimate multiple scattering and secondaries that impact the physics mission of the tracker. The detector components will be described briefly, accompanied by an accounting of the material these they represent.

Compact Geometry Format

- ❏ Human-readable format for describing simple configurations of material
- ❏ org.lcsim GeomConverter takes this and renders in LCDD
- ❏ Distinguishes certain volumes as “sensitive” but handling of segmentation, strip orientation and detector response are left for reconstruction

Current generation is sidaug05



Barrel Silicon

Begin with positions of silicon modules

🔸 Silicon sensors

🔸 Support: same in all layers

🔸 Readout: cable stack scales with barrel length

```
<!-- Barrel Tracker Modules -->
```

```
<detector id="2" name="TrackerBarrel" type="MultiLayerTracker" readout="TkrBarrHits">
  <layer id="1" inner_r = "20.000*cm" outer_z = "26.7*cm">
    <slice material = "PEEK" thickness = "0.02*cm" />
    <slice material = "Rohacell31" thickness="0.14*cm" />
    <slice material = "Epoxy" thickness="0.0175*cm" />
    <slice material = "CarbonFiber" thickness=".016*cm" />
    <slice material = "Silicon" thickness = "0.03*cm" sensitive = "yes" />
    <slice material = "Silicon" thickness = "0.00048*cm" />
    <slice material = "Kapton" thickness = "0.0038*cm" />
    <slice material = "Copper" thickness = "0.00038*cm" />
  </layer>
  <layer id="2" inner_r = "46.300*cm" outer_z = "61.7*cm">
    ...
    <slice material = "Kapton" thickness = "0.0051*cm" />
    <slice material = "Copper" thickness = "0.00052*cm" />
  </layer>
  <layer id="3" inner_r = "72.500*cm" outer_z = "96.7*cm">
    ...
    <slice material = "Kapton" thickness = "0.0064*cm" />
    <slice material = "Copper" thickness = "0.00065*cm" />
  </layer>
  <layer id="4" inner_r = "98.800*cm" outer_z = "131.7*cm">
    ...
    <slice material = "Kapton" thickness = "0.0078*cm" />
    <slice material = "Copper" thickness = "0.00079*cm" />
  </layer>
  <layer id="5" inner_r = "121.300*cm" outer_z = "161.7*cm">
    ...
    <slice material = "Kapton" thickness = "0.0091*cm" />
    <slice material = "Copper" thickness = "0.00093*cm" />
  </layer>
</detector>
```

Barrel Supports

 **Barrel support cylinders:**
inner radius is 2cm inside
inner radius of modules

```
<!-- Barrel Tracker Supports -->
```

```
<detector id="2" name="TrackerBarrelSupports" type="MultiLayerTracker">  
  <layer id="1" inner_r = "18.000*cm" outer_z = "26.7*cm">  
    <slice material = "CarbonFiber" thickness = "0.025*cm" />  
    <slice material = "Rohacell31" thickness="1.3*cm" />  
    <slice material = "CarbonFiber" thickness="0.025*cm" />  
  </layer>  
  <layer id="2" inner_r = "44.300*cm" outer_z = "61.7*cm">  
    ...  
  </layer>  
  <layer id="3" inner_r = "70.500*cm" outer_z = "96.7*cm">  
    ...  
  </layer>  
  <layer id="4" inner_r = "96.800*cm" outer_z = "131.7*cm">  
    ...  
  </layer>  
  <layer id="5" inner_r = "119.300*cm" outer_z = "161.7*cm">  
    ...  
  </layer>  
</detector>
```



Endcap Supports

🔸 Endcap support disks:
begin 3mm beyond ends of
barrels

🔸 Very thick (>2.5 cm) in
current design

🔸 necessary?





```
<!-- Endcap Tracker Supports -->
```

```
<detector id="4" name="TrackerEndcapSupports" type="DiskTracker" reflect="true">  
  <layer id="1" inner_r = "4.0*cm" inner_z = "27.0*cm" outer_r = "25.000*cm">  
    <slice material = "CarbonFiber" thickness = "0.039*cm" />  
    <slice material = "Rohacell31" thickness = "2.5*cm" />  
    <slice material = "CarbonFiber" thickness = "0.039*cm" />  
  </layer>  
  <layer id="2" inner_r = "7.9*cm" inner_z = "62.0*cm" outer_r = "51.300*cm">  
    ...  
  </layer>  
  <layer id="3" inner_r = "11.8*cm" inner_z = "97.0*cm" outer_r = "77.500*cm">  
    ...  
  </layer>  
  <layer id="4" inner_r = "15.6*cm" inner_z = "132.0*cm" outer_r = "103.800*cm">  
    ...  
  </layer>  
  <layer id="5" inner_r = "18.9*cm" inner_z = "162.0*cm" outer_r = "126.300*cm">  
    ...  
  </layer>  
</detector>
```



Endcap Silicon

<!-- Endcap Tracker Modules -->

-  **Double-sided modules treated as two layers each**
-  **4mm separation between sensors in each module**
-  **Readout/support same as for barrels**
-  **Overlap: sensors are 3cm beyond ends of barrel Si**
 ⇒ radius extends 5cm beyond radius of barrel Si
 **pushes in radius of Layer 5**

```

<detector id="3" name="TrackerEndcap" type="DiskTracker" reflect="true" readout="TkrEndcapHits">
  <layer id="1" inner_r = "4.0*cm" inner_z = "30.0*cm" outer_r = "25.000*cm">
    <slice material = "Silicon" thickness = "0.03*cm" sensitive = "yes" />
    <slice material = "Silicon" thickness = "0.00048*cm" />
    <slice material = "Kapton" thickness = "0.0038*cm" />
    <slice material = "Copper" thickness = "0.00038*cm" />
    <slice material = "PEEK" thickness = "0.02*cm" />
    <slice material = "Rohacell31" thickness="0.14*cm" />
    <slice material = "Epoxy" thickness="0.0175*cm" />
    <slice material = "CarbonFiber" thickness=".016*cm" />
  </layer>
  <layer id="2" inner_r = "4.0*cm" inner_z = "30.4*cm" outer_r = "25.000*cm">
    <slice material = "Silicon" thickness = "0.03*cm" sensitive = "yes" />
    <slice material = "Silicon" thickness = "0.00048*cm" />
    <slice material = "Kapton" thickness = "0.0038*cm" />
    <slice material = "Copper" thickness = "0.00038*cm" />
  </layer>
  <layer id="3" inner_r = "7.9*cm" inner_z = "65.0*cm" outer_r = "51.300*cm">
    ...
  </layer>
  <layer id="4" inner_r = "7.9*cm" inner_z = "65.4*cm" outer_r = "51.300*cm" >
    ...
  </layer>
  <layer id="5" inner_r = "11.8*cm" inner_z = "100.0*cm" outer_r = "77.500*cm" >
    ...
  </layer>
  <layer id="6" inner_r = "11.8*cm" inner_z = "100.4*cm" outer_r = "77.500*cm">
    ...
  </layer>
  <layer id="7" inner_r = "15.6*cm" inner_z = "135.0*cm" outer_r = "103.800*cm">
    ...
  </layer>
  <layer id="8" inner_r = "15.6*cm" inner_z = "135.4*cm" outer_r = "103.800*cm">

```

etc...

Barrel Support Rings

Between end of barrel
and inside of disk in z

Span from inner radius of
one cylinder to the next

```
<!-- Tracker Support Rings -->
```

```
<detector id="2" name="TrackerSupportRings" type="DiskTracker" reflect="true">  
  <layer id="1" inner_r = "18.000*cm" inner_z = "26.7*cm" outer_r = "44.300*cm">  
    <slice material = "CarbonFiber" thickness = "0.15*cm" />  
  </layer>  
  <layer id="2" inner_r = "44.300*cm" inner_z = "61.7*cm" outer_r = "70.500*cm">  
    ...  
  </layer>  
  <layer id="3" inner_r = "70.500*cm" inner_z = "96.7*cm" outer_r = "96.800*cm">  
    ...  
  </layer>  
  <layer id="4" inner_r = "96.800*cm" inner_z = "131.7*cm" outer_r = "119.300*cm">  
    ...  
  </layer>  
  <layer id="5" inner_r = "119.300*cm" inner_z = "161.7*cm" outer_r = "126.5*cm">  
    ...  
  </layer>  
</detector>
```



Power/Readout Distribution

❏ DC/DC conversion minimizes cable plant

❏ Optical links require no cooling

❏ Mounted on outer surface of support rings except in Layer 5

❏ **ECAL constraint reduces Layer 5 length**

❏ Assume each board can service 20 readout chips (1/2 L5 barrel phi-slice)

❏ Assume modules that are 5cm × 5cm below $r=20\text{cm}$ in endcaps

<!-- Tracker Readout/Power Distribution System -->

```
<detector id="2" name="TrackerReadout" type="DiskTracker" reflect="true">
  <layer id="1" inner_r = "25.500*cm" inner_z = "27.0*cm" outer_r = "44.300*cm">
    <slice material = "G10" thickness = "0.057*cm" />
    <slice material = "Copper" thickness = "0.0038*cm" />
  </layer>
  <layer id="2" inner_r = "51.800*cm" inner_z = "62.0*cm" outer_r = "70.500*cm">
    <slice material = "G10" thickness = "0.102*cm" />
    <slice material = "Copper" thickness = "0.0068*cm" />
  </layer>
  <layer id="3" inner_r = "78.000*cm" inner_z = "97.0*cm" outer_r = "96.800*cm">
    <slice material = "G10" thickness = "0.108*cm" />
    <slice material = "Copper" thickness = "0.0072*cm" />
  </layer>
  <layer id="4" inner_r = "104.300*cm" inner_z = "132.0*cm" outer_r = "119.300*cm">
    <slice material = "G10" thickness = "0.186*cm" />
    <slice material = "Copper" thickness = "0.0124*cm" />
  </layer>
  <layer id="5" inner_r = "104.300*cm" inner_z = "167.0*cm" outer_r = "119.300*cm">
    <slice material = "G10" thickness = "0.246*cm" />
    <slice material = "Copper" thickness = "0.0164*cm" />
  </layer>
</detector>
```

Alternate Designs

Two require changes
to tracker:

- ❏ $r_{\max}=1\text{m}$ with
same proportions
($\cos\theta_{\text{barrel-disk}}=0.8$)
- ❏ $|z|_{\max}=2\text{m}$ with
same r_{\max}
($\cos\theta_{\text{barrel-disk}}=0.848$)

inner radius stays the
same for both

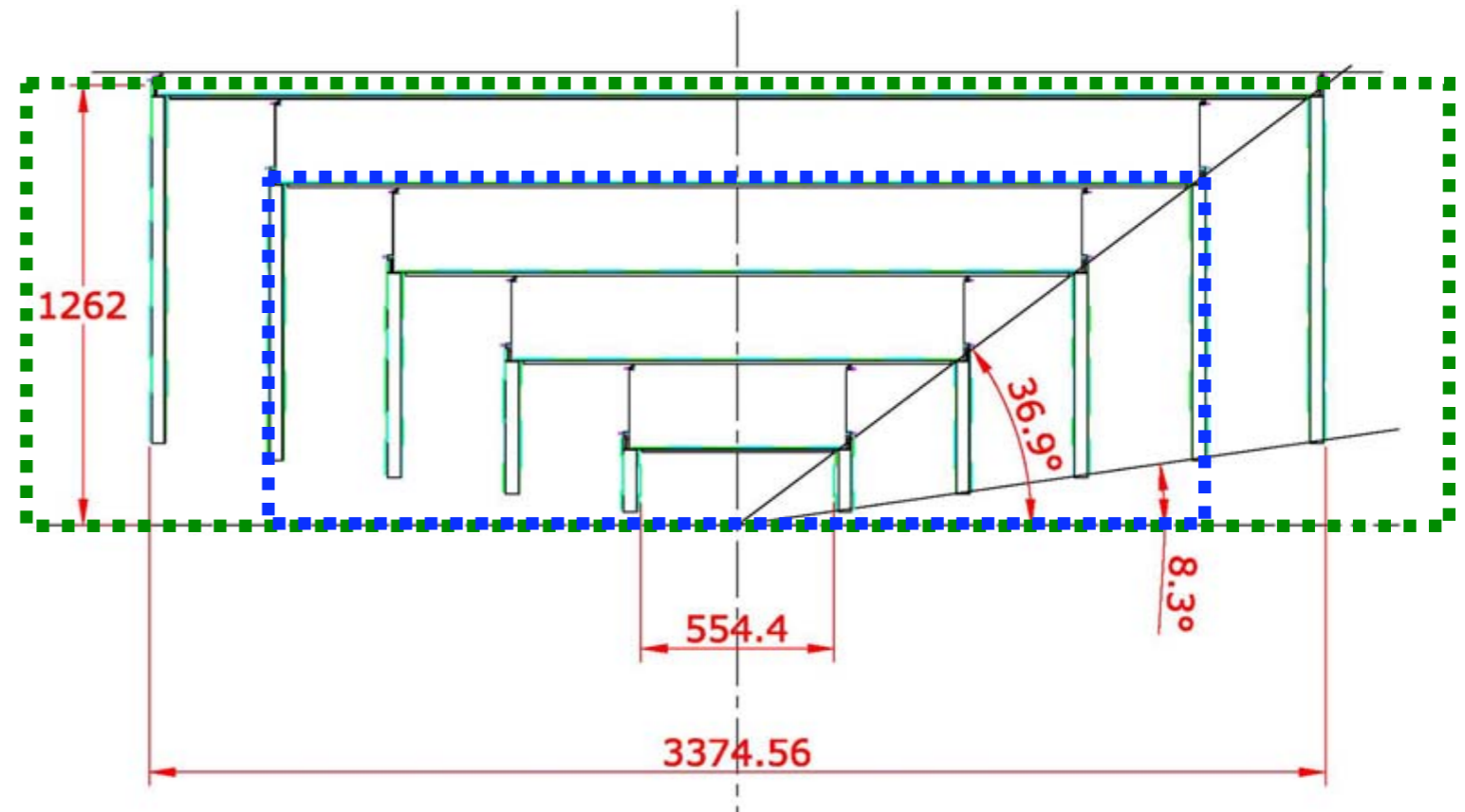

“Small” Alternative

<!-- Barrel Tracker Modules -->

```
<detector id="2" name="TrackerBarrel" type="MultiLayerTracker" readout="TkrBarrHits">
  <layer id="1" inner_r = "20.000*cm" outer_z = "26.7*cm">
    <slice material = "PEEK" thickness = "0.02*cm" />
    <slice material = "Rohacell31" thickness="0.14*cm" />
    <slice material = "Epoxy" thickness="0.0175*cm" />
    <slice material = "CarbonFiber" thickness=".016*cm" />
    <slice material = "Silicon" thickness = "0.03*cm" sensitive = "yes" />
    <slice material = "Silicon" thickness = "0.00048*cm" />
    <slice material = "Kapton" thickness = "0.0038*cm" />
    <slice material = "Copper" thickness = "0.00038*cm" />
  </layer>
  <layer id="2" inner_r = "39.400*cm" outer_z = "52.6*cm">
    ...
    <slice material = "Kapton" thickness = "0.0051*cm" />
    <slice material = "Copper" thickness = "0.00052*cm" />
  </layer>
  <layer id="3" inner_r = "58.800*cm" outer_z = "78.5*cm">
    ...
    <slice material = "Kapton" thickness = "0.0064*cm" />
    <slice material = "Copper" thickness = "0.00065*cm" />
  </layer>
  <layer id="4" inner_r = "78.300*cm" outer_z = "104.4*cm">
    ...
    <slice material = "Kapton" thickness = "0.0078*cm" />
    <slice material = "Copper" thickness = "0.00079*cm" />
  </layer>
  <layer id="5" inner_r = "94.900*cm" outer_z = "126.6*cm">
    ...
    <slice material = "Kapton" thickness = "0.0091*cm" />
    <slice material = "Copper" thickness = "0.00093*cm" />
  </layer>
</detector>
```

 Scaled from baseline
sidaug05 description

 Same overlaps and
clearances

 Same material
assumptions



“Long” Alternative

```
<!-- Barrel Tracker Modules -->
```

```
<detector id="2" name="TrackerBarrel" type="MultiLayerTracker" readout="TkrBarrHits">
  <layer id="1" inner_r = "20.000*cm" outer_z = "31.7*cm">
    <slice material = "PEEK" thickness = "0.02*cm" />
    <slice material = "Rohacell31" thickness="0.14*cm" />
    <slice material = "Epoxy" thickness="0.0175*cm" />
    <slice material = "CarbonFiber" thickness=".016*cm" />
    <slice material = "Silicon" thickness = "0.03*cm" sensitive = "yes" />
    <slice material = "Silicon" thickness = "0.00048*cm" />
    <slice material = "Kapton" thickness = "0.0038*cm" />
    <slice material = "Copper" thickness = "0.00038*cm" />
  </layer>
  <layer id="2" inner_r = "46.300*cm" outer_z = "73.7*cm">
    ...
    <slice material = "Kapton" thickness = "0.0051*cm" />
    <slice material = "Copper" thickness = "0.00052*cm" />
  </layer>
  <layer id="3" inner_r = "72.500*cm" outer_z = "115.7*cm">
    ...
    <slice material = "Kapton" thickness = "0.0064*cm" />
    <slice material = "Copper" thickness = "0.00065*cm" />
  </layer>
  <layer id="4" inner_r = "98.800*cm" outer_z = "157.7*cm">
    ...
    <slice material = "Kapton" thickness = "0.0078*cm" />
    <slice material = "Copper" thickness = "0.00079*cm" />
  </layer>
  <layer id="5" inner_r = "121.300*cm" outer_z = "193.7*cm">
    ...
    <slice material = "Kapton" thickness = "0.0091*cm" />
    <slice material = "Copper" thickness = "0.00093*cm" />
  </layer>
</detector>
```

 Scaled from baseline sidaug05 description

 Same overlaps and clearances

 Same material assumptions



Physics Studies

We need:

- Ability to generate Monte Carlo with new detector model
 - Identify benchmark physics modes
 - Tracking performance benchmarks
 - Reconstruction code enabling realistic tests of these benchmarks
-
- ```
graph TD; A[Ability to generate Monte Carlo with new detector model] --> B[Identify benchmark physics modes]; B --> C[Tracking performance benchmarks]; C --> D[Reconstruction code enabling realistic tests of these benchmarks];
```





# Status of Track Reconstruction

- ❖ Some nice tools were available in hep.lcd framework
  - ❖ VXD-seeded track reconstruction
  - ❖ ECal-seeded tracking
  - ❖ Fitting
  - ❖ Vertexing
- ❖ hep.lcd lacks some important facilities including better geometry description capabilities: org.lcsim addresses these
- ❖ **Need to get the above tools into org.lcsim**
- ❖ **Silicon charge deposition/clustering**
- ❖ **Simulation of various readout segmentations and strip orientations**



# Next for Tracker Geometry

- ❏ Reshuffle to restore even spacing between layers
- ❏ Consider consequences of split in endcaps that accommodate VXD removal
- ❏ Consider more radical alternatives
  - ❏ 8 layers?
  - ❏ Double-sided barrel layer(s)?
  - ❏ ultra-low-mass designs (Bruce Schumm, Justin Albert)?



# Conclusions

- ❏ Material simulation in-hand for baseline detector and variants
- ❏ **Have simplified versions in B. Schumm's format for generating mc.fast smearing numbers with lcdtrk**
- ❏ **Track reconstruction is first priority: much needs to be done and we need your help.**

***Detector outline is not far away...***

