

Mechanical Considerations in the Outer Tracker and VXD

Bill Cooper
Fermilab

Overview

- I'll describe developments since the SLAC workshop in mechanical design efforts at Fermilab related to SiD tracking.
 - I'll start with a brief suggestion of details relevant to the design of the outer tracker.
 - The remainder of the talk will raise questions and address a few issues which might influence the overall VXD design.
 - All of this represents work in process.
- I won't cover efforts which have been described very well in other talks.
 - Structure of tracker modules
 - Baseline tracker and SiD geometry
 - Simulation studies

Layout of Outer Tracker Barrels with a Single Type of Module

- The layout shows one way in which modules in boxes could be arranged to provide overlap between all adjoining sensors.
 - It assumes single-sensor modules.
 - It retains the assumption of 5 barrels with axially aligned sensors, but it could be modified to accommodate other choices.
 - Modules are staggered in Z (different radii) and have pinwheel overlap in Phi.
 - There may be other arrangements which would work at least as well.

Layout of Outer Tracker Barrels with a Single Type of Module

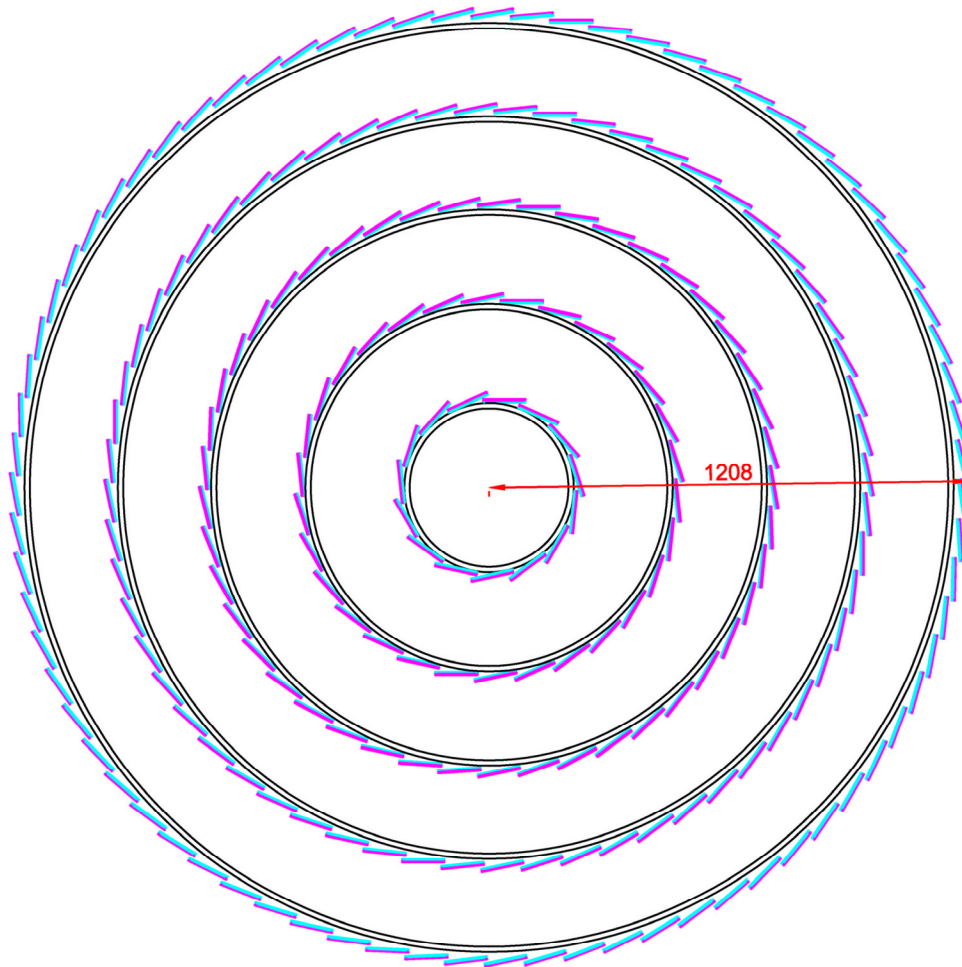

Sensors:

Cut dim's: 104.44 W x 84 L

Active dim's: 102.4 W x 81.96 L

Boxes:

Outer dim's: 107.44 W x 87 L x 4 H

Support cylinders:

OR: 213.5, 462.5, 700, 935, 1170

Number of phi: 15, 30, 45, 60, 75

Central tilt angle: 10 degrees

Sensor phi overlap (mm):

Barrel 1: 5.3

Barrel 2: 0.57

Barrel 3: 0.40

Barrel 4: 0.55

Barrel 5: 0.63

Cyan and magenta sensors and boxes are assumed to be at different Z's and to overlap in Z.

Within a given barrel, cyan sensors overlap in phi as do magenta sensors.

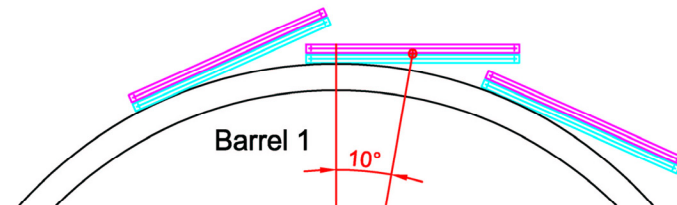

Layout of Outer Tracker Barrels with a Single Type of Module

- Both barrels and modules have somewhat different geometry from simulation.
 - Different barrel radii
 - Partly a result of integer arithmetic in Phi
 - Partly in recognition of inner and outer boundaries
 - 4 mm high module boxes
 - Higher boxes did not seem to provide sensible sensor-sensor overlaps and the desired tilt angle while allowing a single type of sensor.
- Module and sensor dimensions and overlaps between sensors are realistic.
 - Sensor length was chosen to be consistent with 6" wafer technology.
 - Overlaps are greater than 0.4 mm.

Layout of Outer Tracker Barrels with a Single Type of Module

- A possible concern which should receive attention:
 - Precision of angular alignment of modules for stand-alone tracking (that is, with limited information regarding the Z-position of a hit)
 - The issue is how precisely a sensor can be placed rather than how well its position can be known.
 - Poor angular alignment degrades resolution in the absence of Z-information.

March 2005 Concept of an Open Tracker

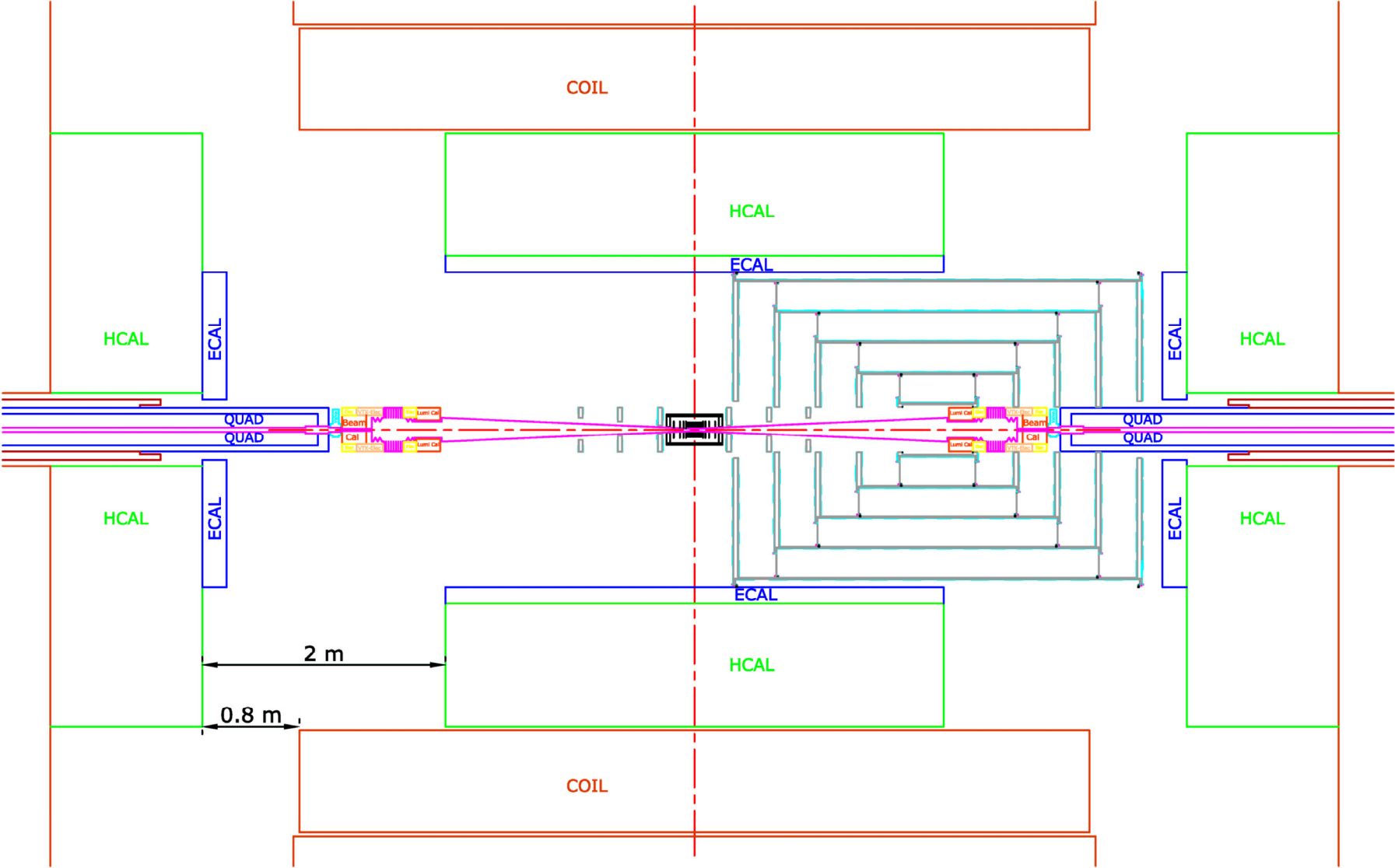

Overall Design Questions

- How are cables and services supported as the end-caps are opened and closed?
- What are the outer tracker support details which allow it to be moved longitudinally?
- How accurately are the quads positioned and how stably are they supported?

Vertex Chamber Questions

- What is the detailed geometry of the beam pipe?
 - What wall thickness as a function of Z is needed to avoid collapse under vacuum?
 - What wall thickness is needed to address misalignments which occur as the end-caps are opened and closed?
- Forward disks
 - How are the “forward disks” supported?
 - What dimensions should they have?
- What sets alignment of the vertex chamber and forward disks with respect to the outer tracker?

Vertex Chamber Questions

- What is the baseline operating temperature?
 - Does a sandwich construction for “ladders” ensure adequate control of thermal bowing?
 - What foam should be used in the sandwich?
 - How do we deal with thermal contraction of cables and readout fibers?
 - Anchoring cables and fibers impacts the design of end plates to support the ladders.
 - How is dry gas for cooling distributed?
 - What is the heat leak from surrounding structures?
- What is the power dissipation of the readout?
- How do we ensure that dry gas flow will not cause excessive vibration?
 - Heat leak, readout power dissipation, and the required uniformity of temperature determine the required gas flow rate.

Beam Tube

- For guidance, I've assumed an all beryllium, thin-walled beam tube and made standard Rourke and Young collapse calculations.
- The wall thickness to avoid collapse under 30 psid external pressure (a reasonable requirement for vacuum design) is shown below.
- $R = 12 \text{ mm} \longleftrightarrow t = 0.165 \text{ mm}$ (a familiar number)

R varies linearly with t

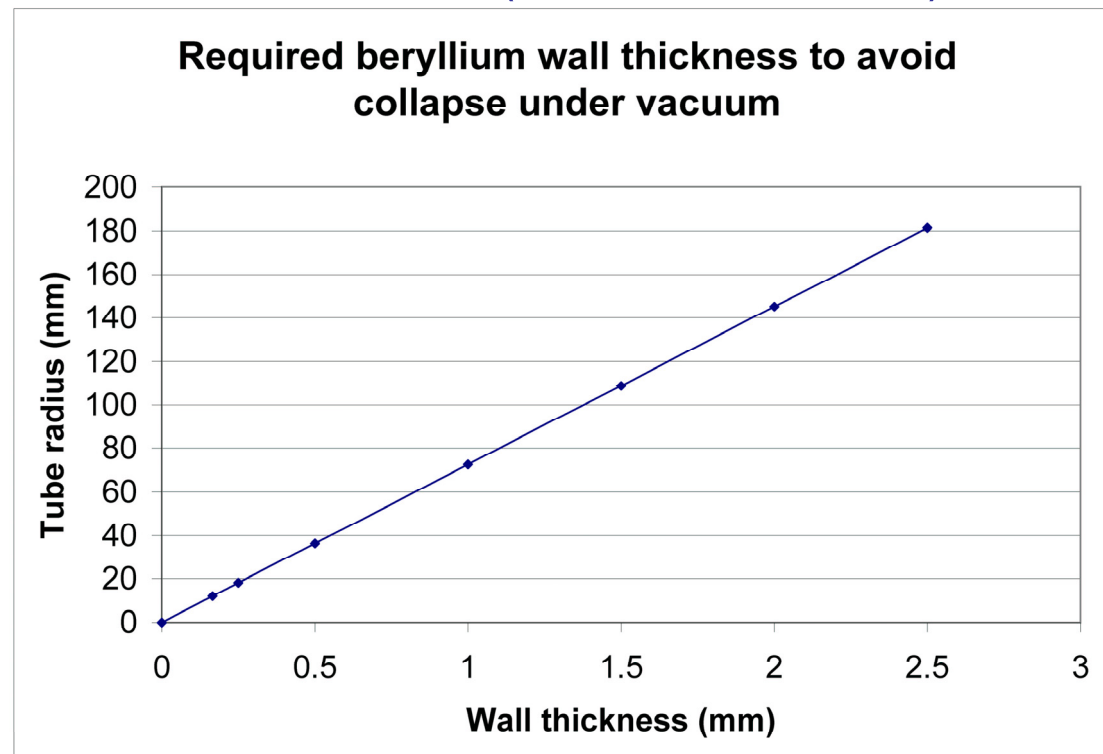

Beam Tube

- For a cone angle with $dR/dZ = 17/351$ starting at $(R,Z) = (12 \text{ mm}, 62.5 \text{ mm})$, the wall thickness to address vacuum is shown below. For SS, the wall thickness would increase by a factor of 1.145.

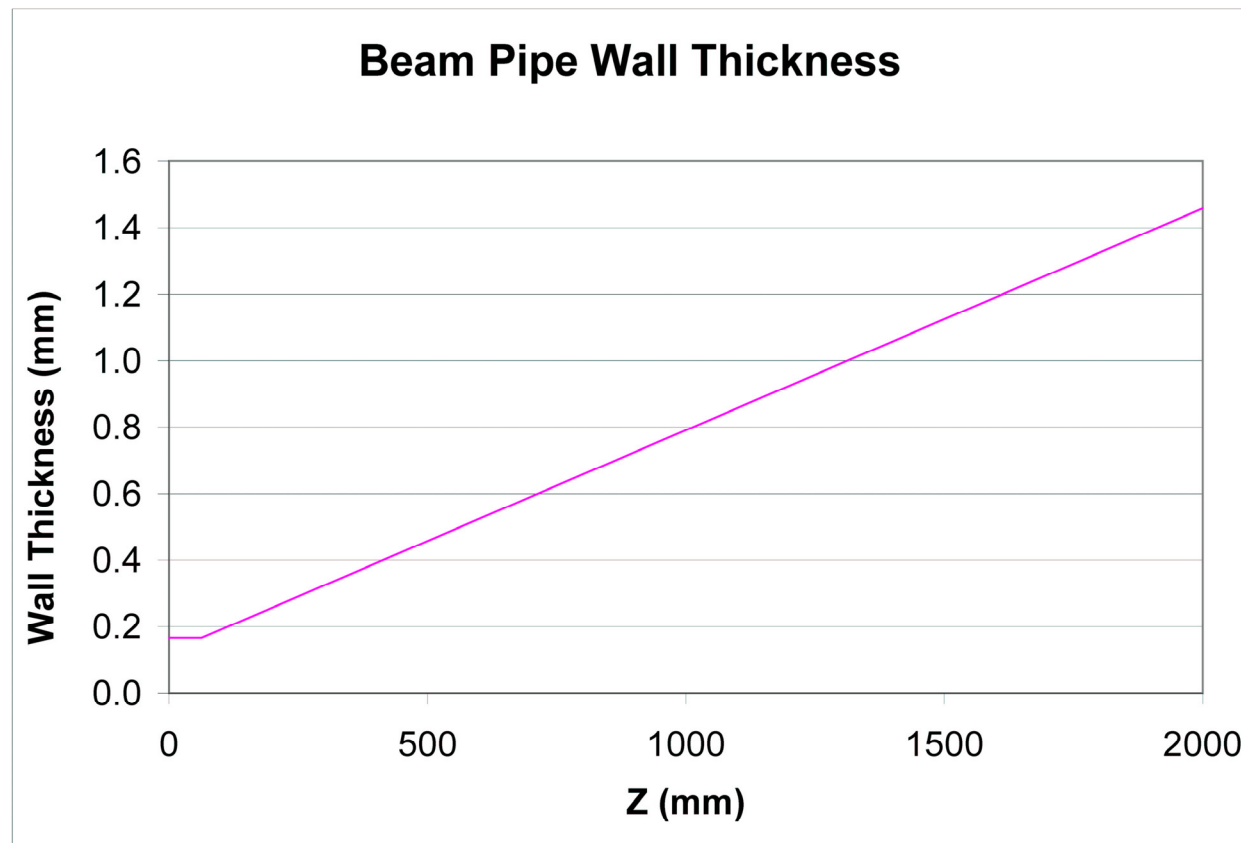

Beam Tube Joints

- Brush-Wellman Electrofusion developed a proprietary electron beam brazing technique for beryllium to beryllium joints. The braze material is thought to be aluminum.
- Joint concept for 1.16" OD (14.7 mm OR) DZero beam pipe:

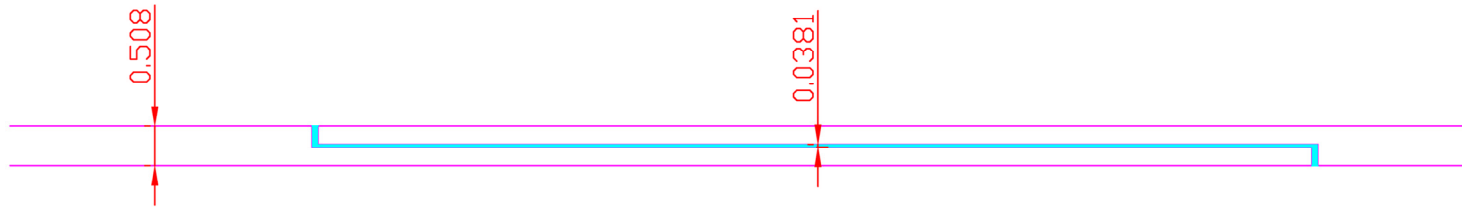

- Similar concept for ILC:

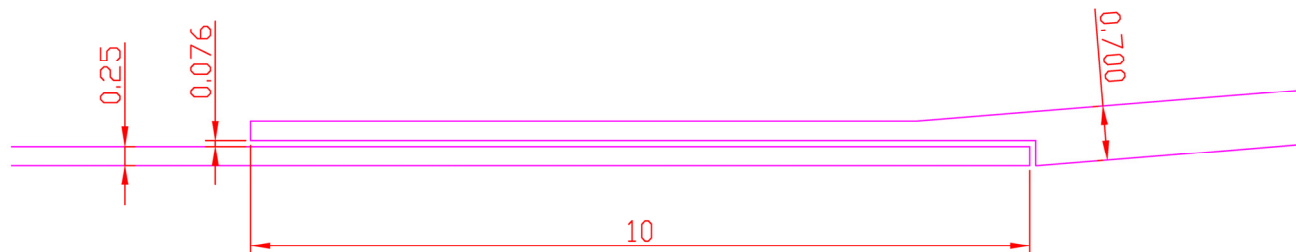

Beam Tube Deflection (Preliminary)

- Wall thickness has been taken to be the minimum to avoid collapse.
 - We might learn later that that isn't make sufficient.
- Weight of a 10 m (conservatively long) beam tube \approx 34.7 Kg.
- Simple support from ends doesn't work.
- Stresses and deflections are unacceptable: 436 KSI and 590 mm.

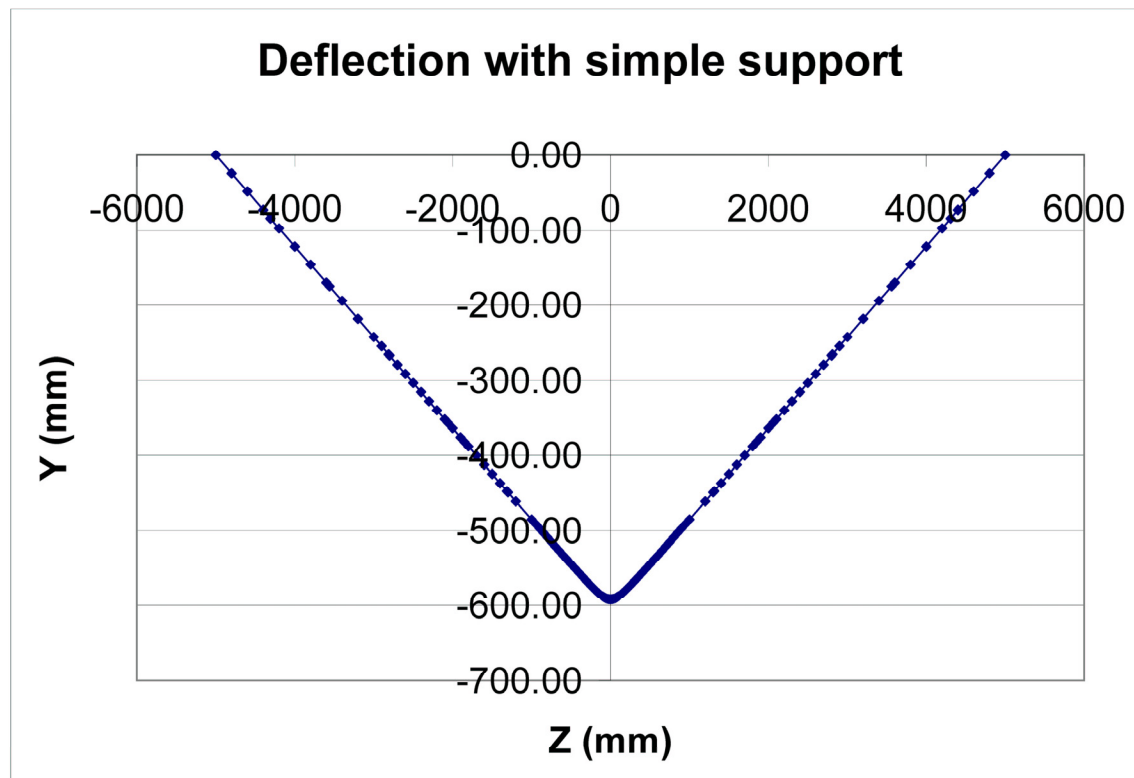

Beam Tube Deflection (Preliminary)

- Deflection of the same beryllium beam tube under its own weight with the ends held aligned
- Deflections and stresses are negligible.

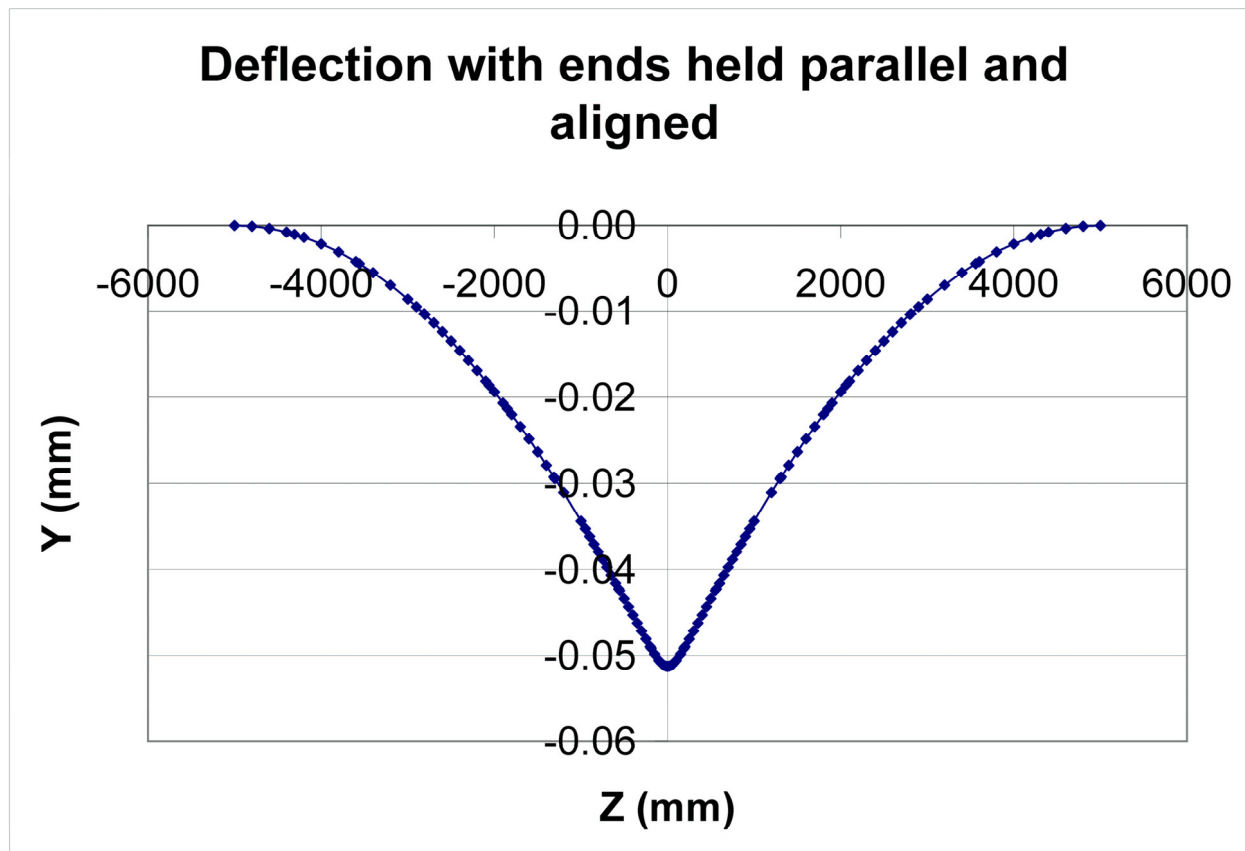

Beam Tube Deflection (Preliminary)

- With ends reasonably guided, beam tube stresses are OK.
- Maximum stress ≈ 2.9 KSI for a parallel offset of 1 mm.
- Braze joint stresses will need to be examined.

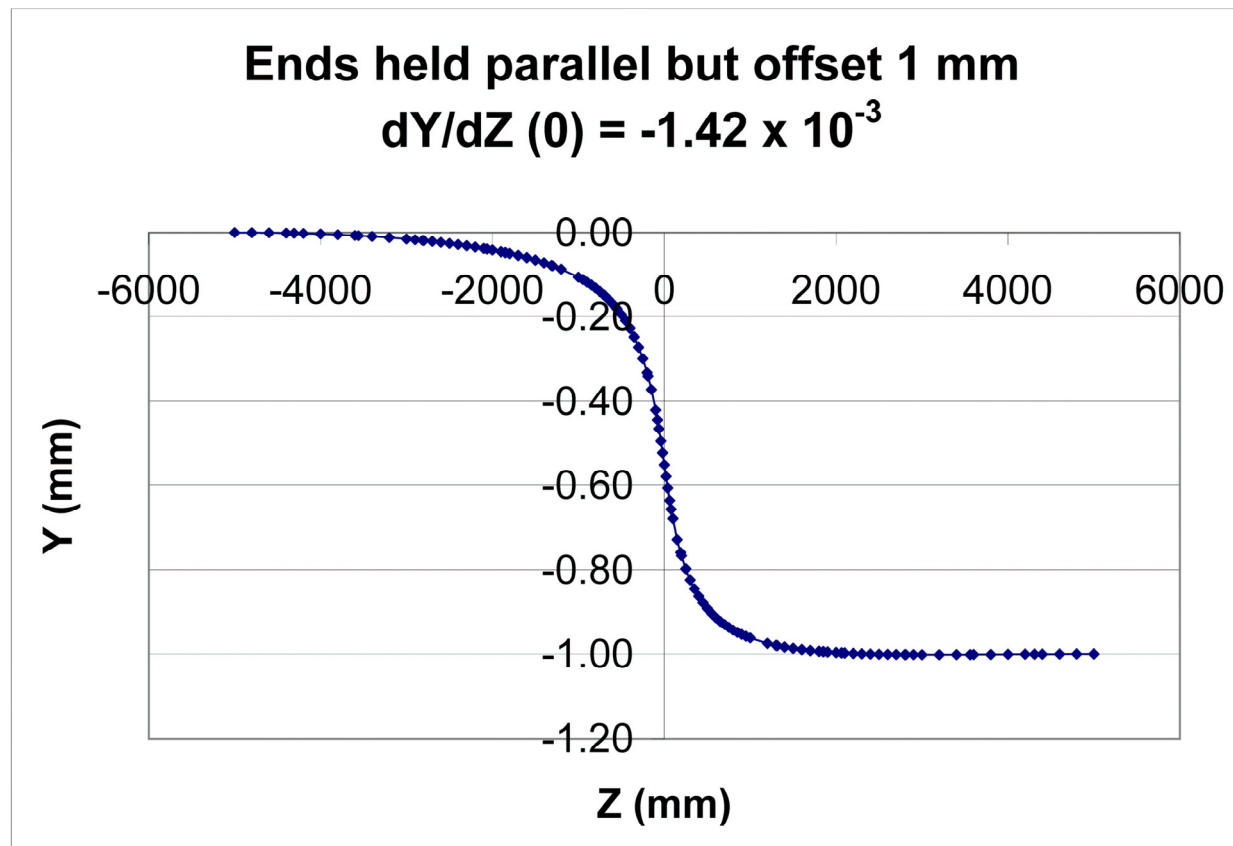

Beam Tube Deflection (Preliminary)

- Deflection with additional symmetric loads of 250 grams at $Z = \pm 900$ mm and beam tube ends aligned.
- Additional deflection from the 250 gram loads is negligible.

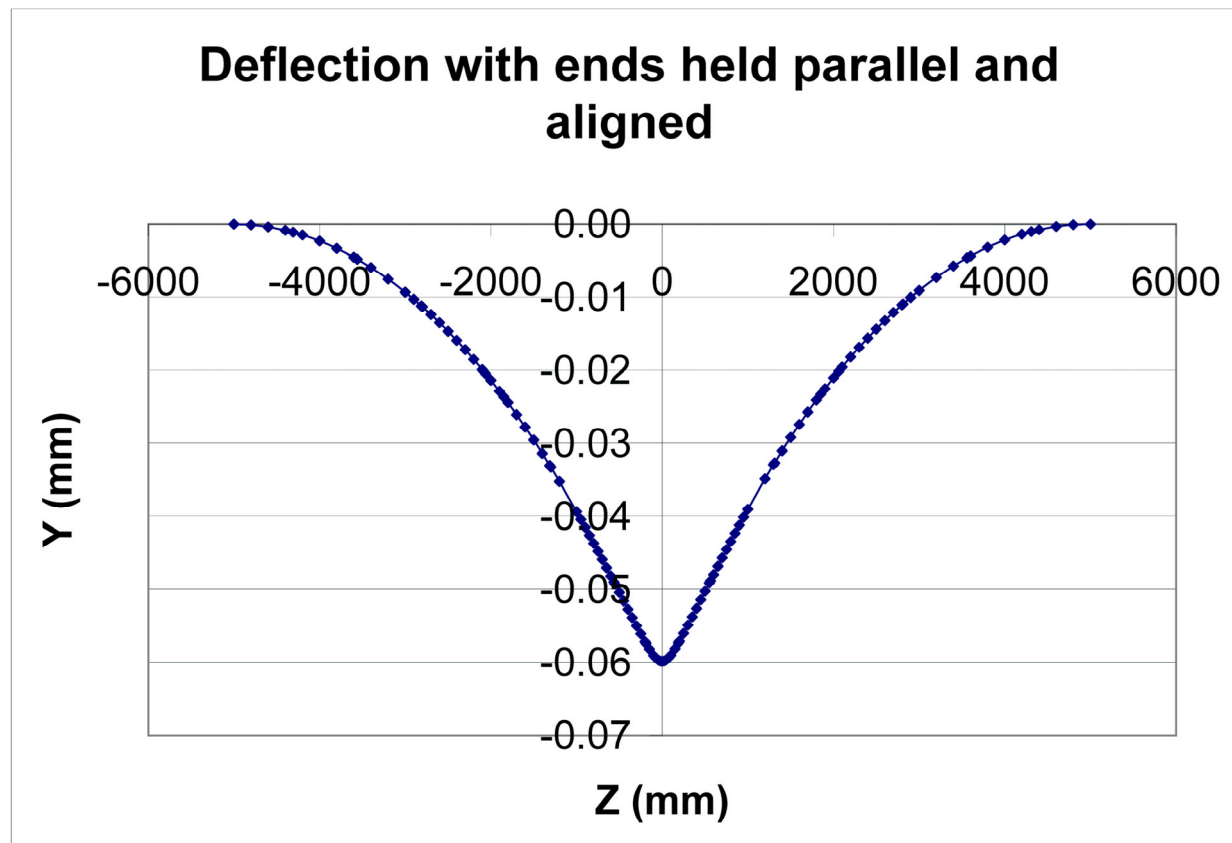

Concept of Inner Tracker (VXD) Support

- The previously discussed VXD plus disks beyond each end of it are supported within an insulating, double-walled cylinder.
- Note that an obsolete outer tracker geometry is shown.

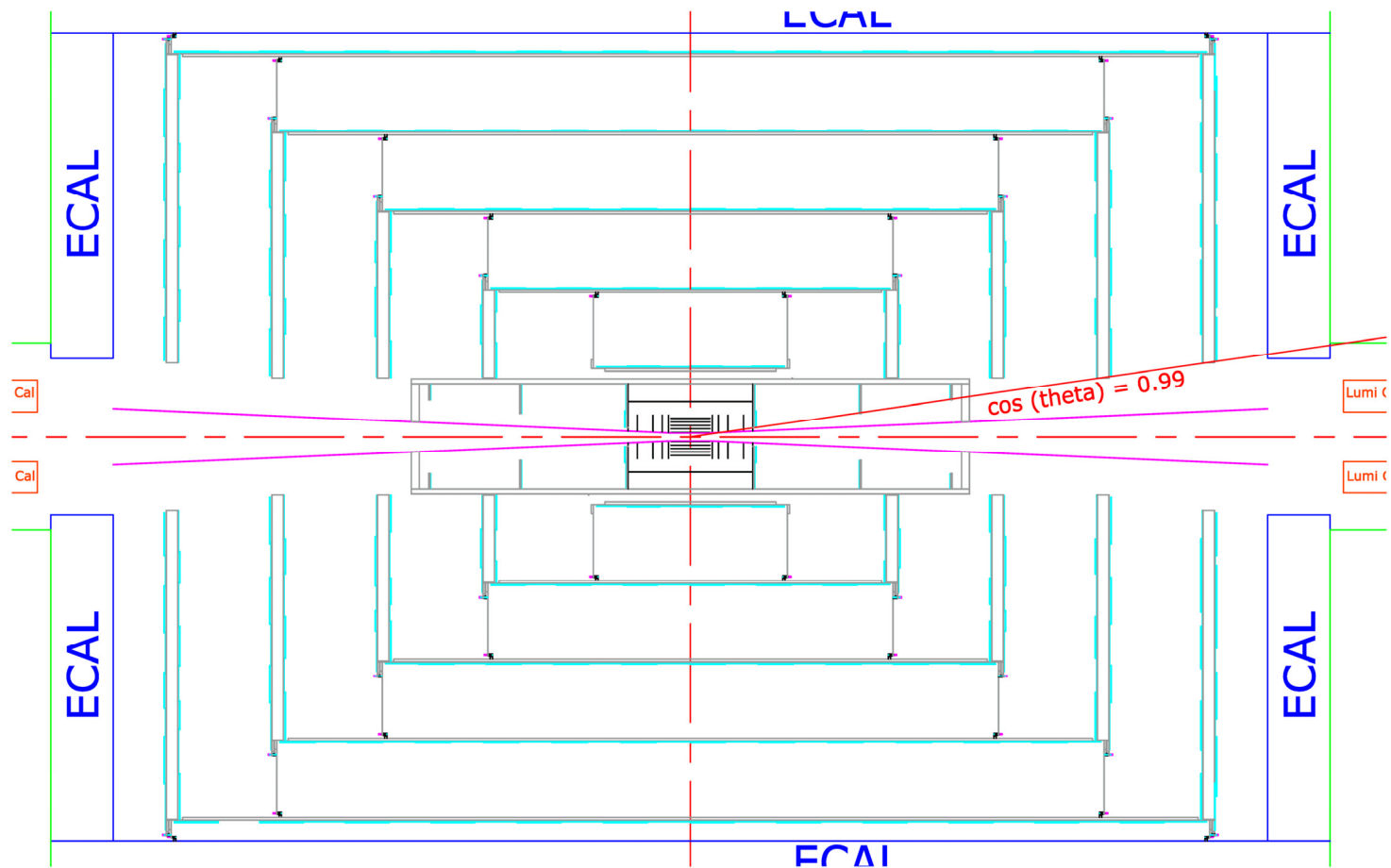

Concept of Inner Tracker (VXD) Support

- The cylinder bears on the beam tube at $Z = \pm 880$ mm and $Z = \pm 200$ mm.
- In addition to supporting detector elements, the cylinder aids in keeping the beam tube straight.

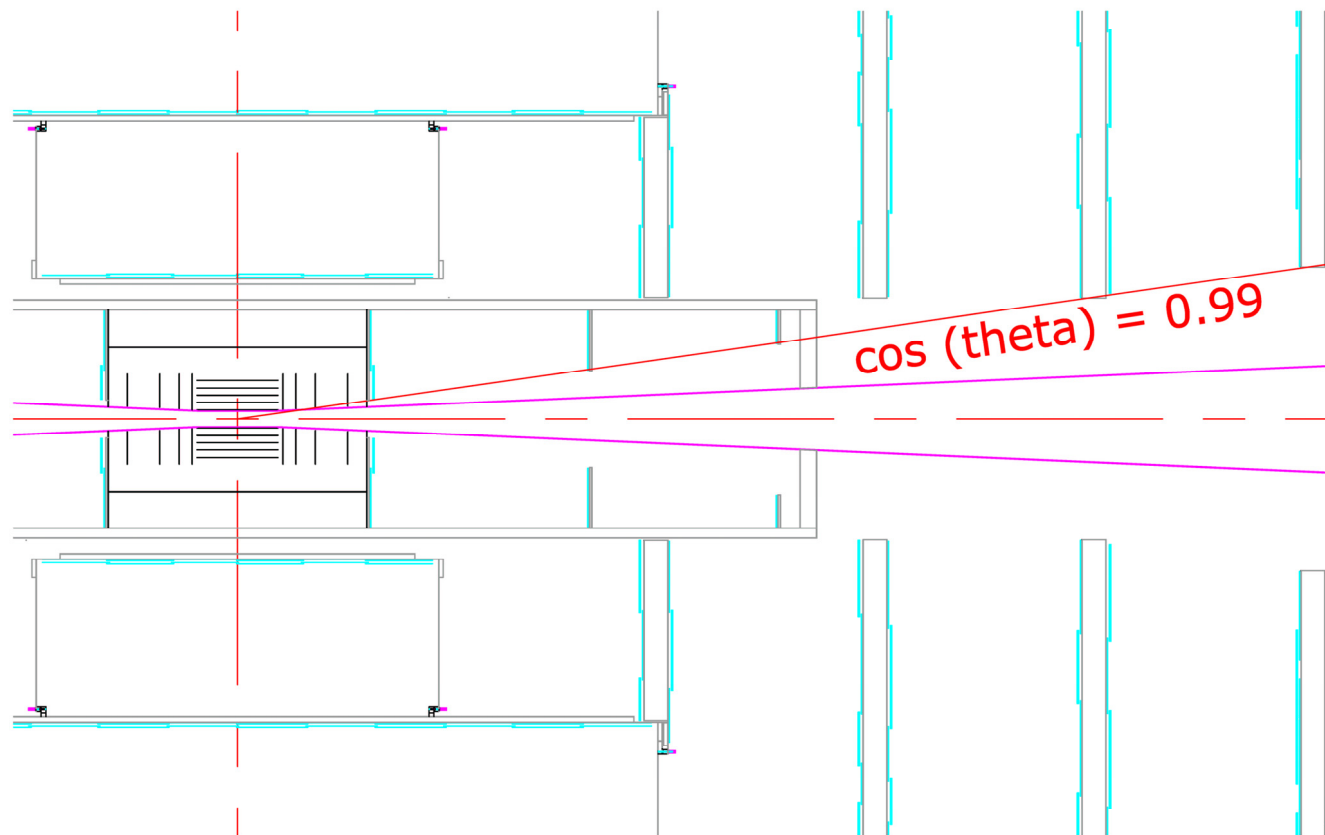

Concept of Inner Tracker (VXD) Support

- Beam tube deflection calculations remain to be completed.
- Note that:
 - Cables can be dressed along the beam tube but need to avoid one disk.
 - “Forward disks” are in a thermal enclosure
 - Some space along the beam tube is available for readout.

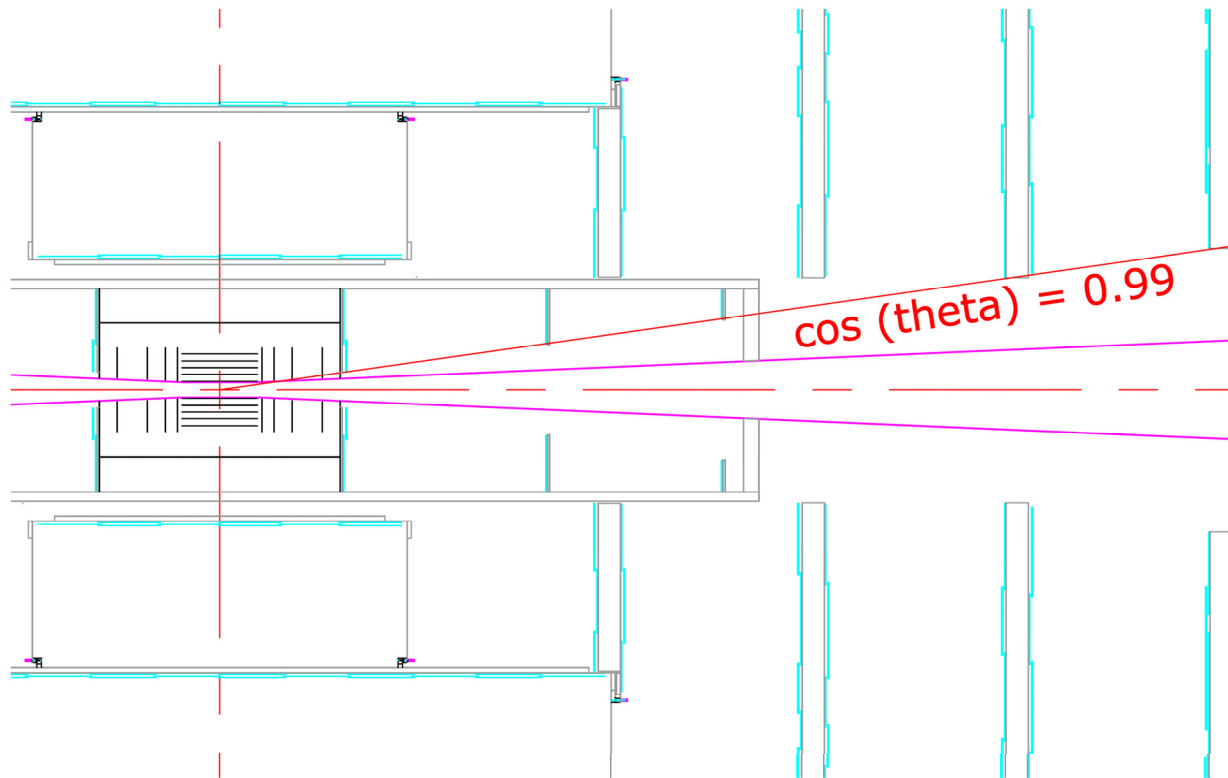

Concept of Inner Tracker (VXD) Support

- An additional cylinder is shown to aid in VXD support.
 - We may not need it.
 - We should be able to match longitudinal thermal contraction of a carbon fiber cylinder to that of silicon.
 - Leaf spring fingers in end membranes of the cylinder can provide longitudinal compliance.

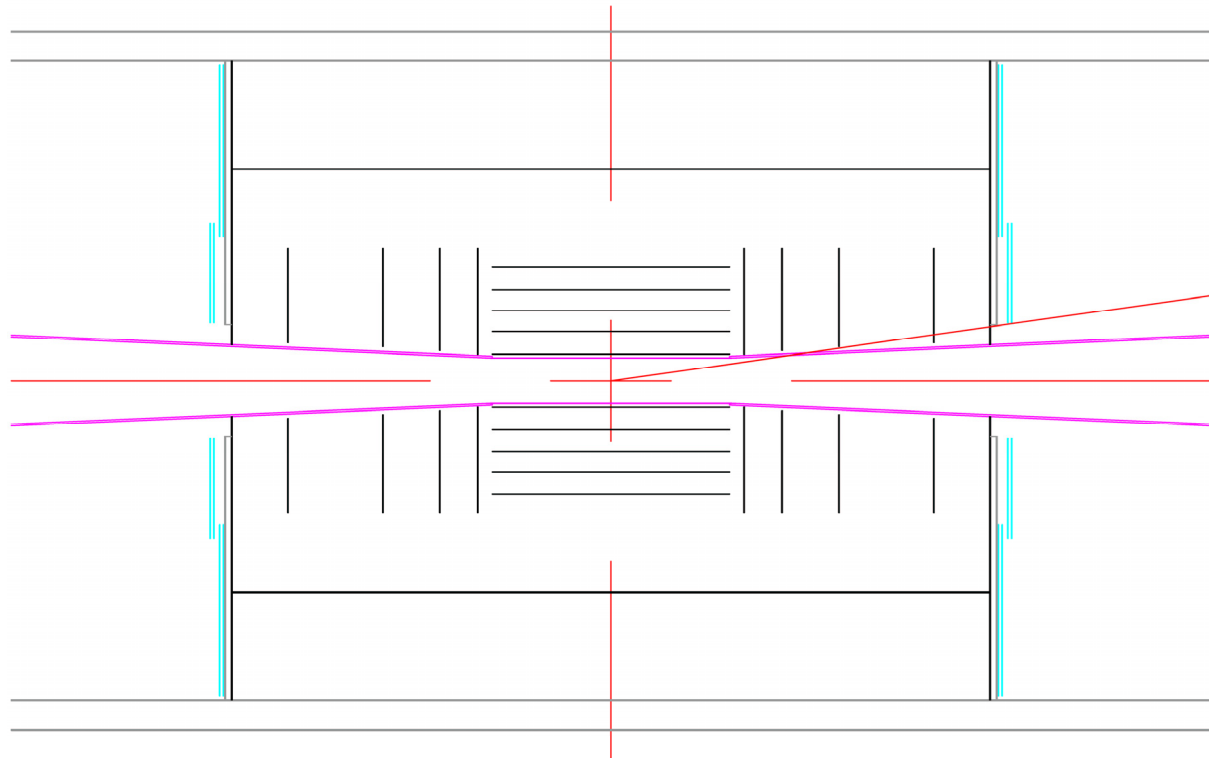

Concept of Inner Tracker (VXD) Support

- We will need to look at the joint details between central and conical beam pipe sections carefully to allow space for the first disk.
- Barrel and disk support details have not been addressed yet.

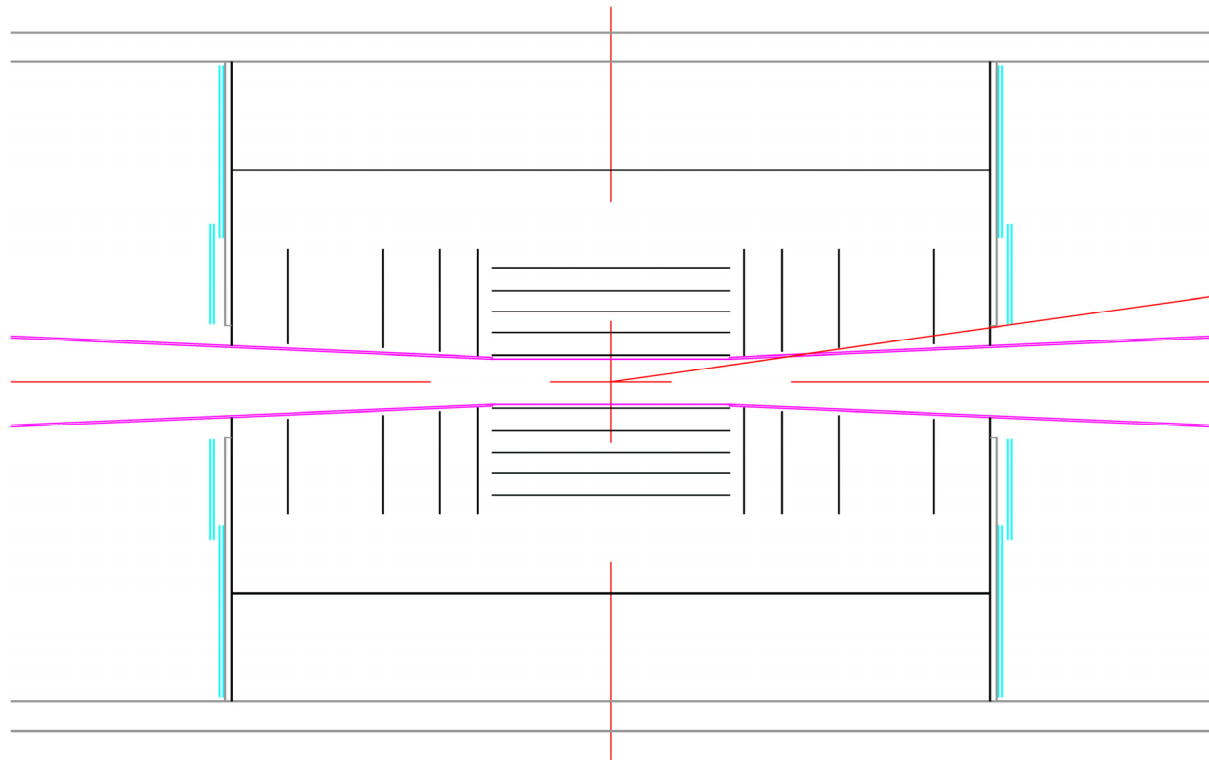

Thermal Bowing of VXD “Ladders”

- Simple two-dimensional model for ladders with length \gg width
- Takes into account elastic moduli and cross-sections but ignores the stiffnesses of an individual components
- Assumes silicon – epoxy – carbon foam – epoxy – silicon sandwich and examines the effects of non-equal epoxy layer thicknesses

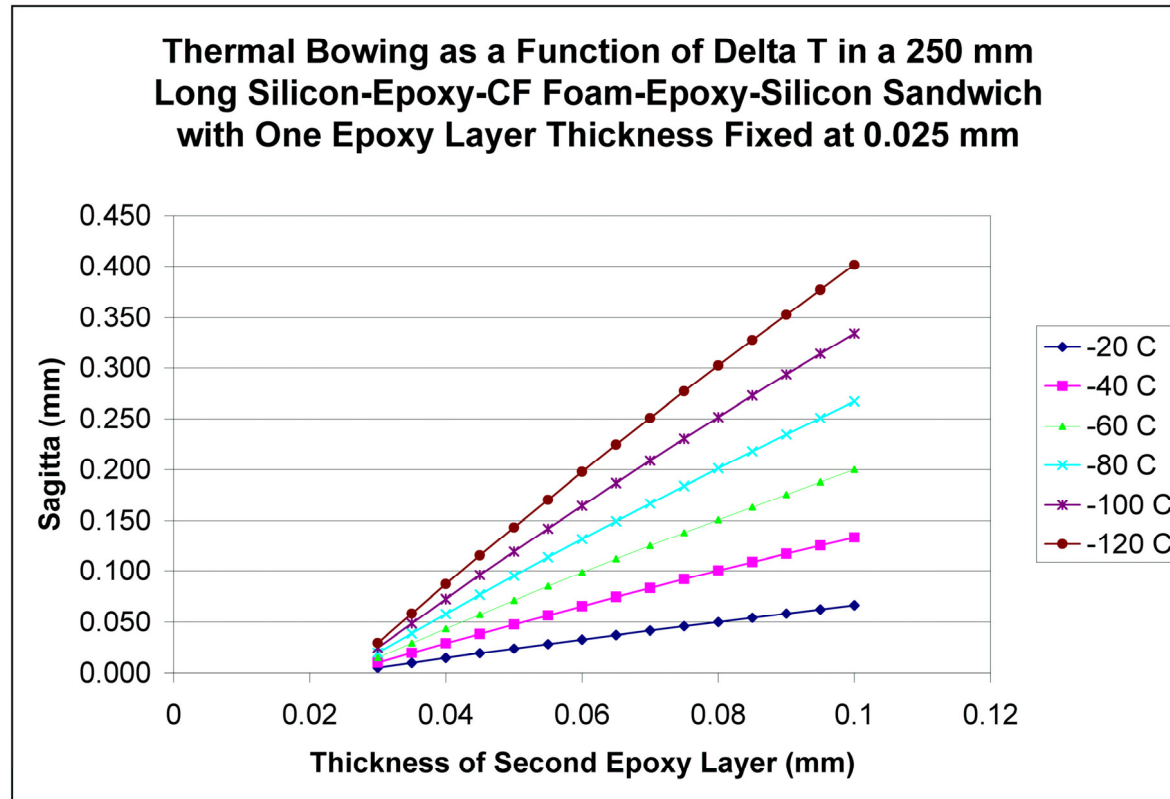

Thermal Bowing of VXD “Ladders”

- Effects of ladder length and temperature for epoxy thicknesses of 0.035 mm and 0.025 mm

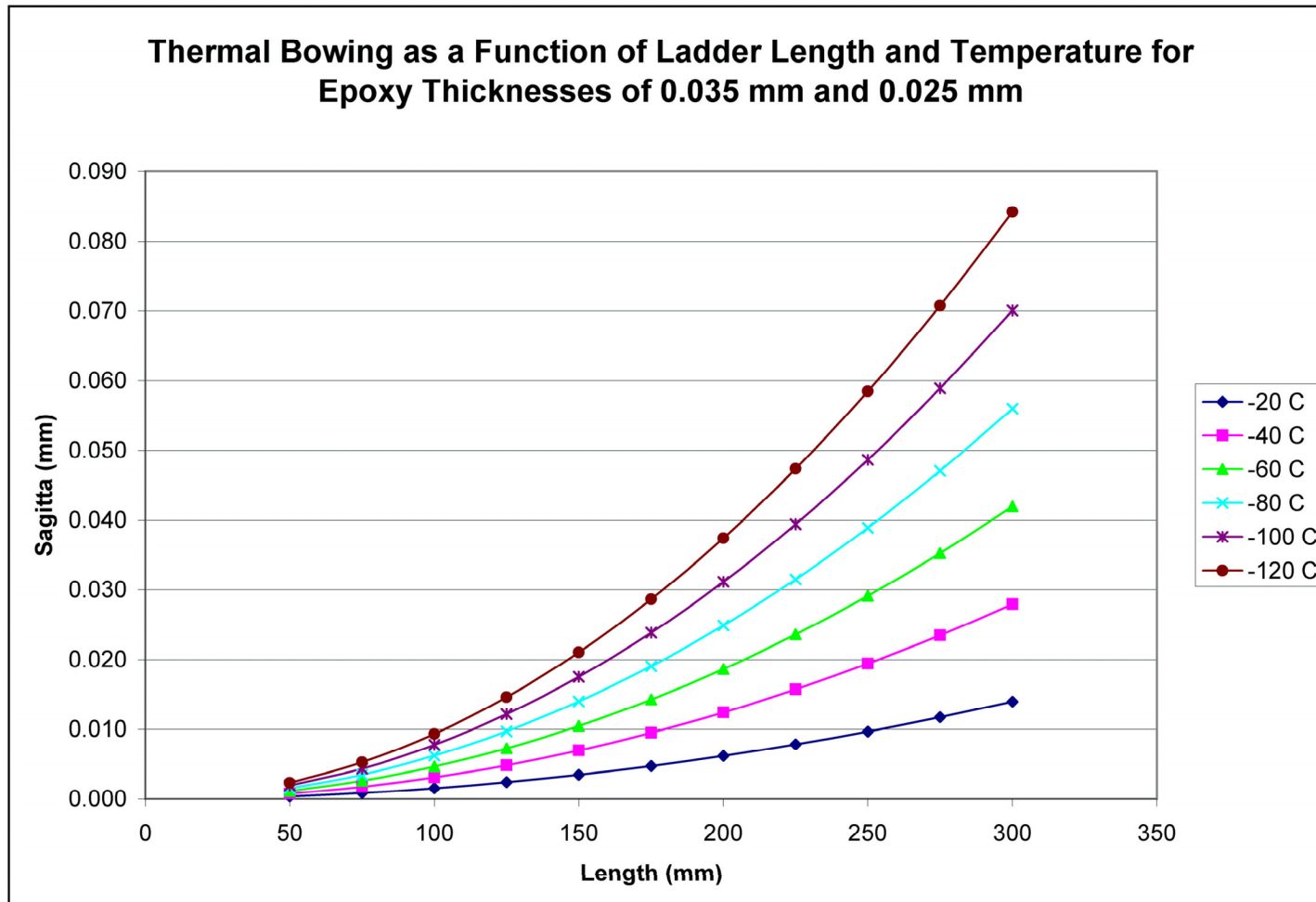

In Summary

- We have begun to accumulate a shopping list of questions to be answered.
- Some issues have been partially addressed; others, such as cabling, have not been (yet).
- Proceeding with the mechanical design may suggest answers to many of the questions.