

Main Linac Basics

D. Schulte

Introduction



Stepping Stones

- Introduction
- Accelerating structures
- Power efficiency
- Beam parameters
 - single bunch longitudinal wakefield and energy spread
 - beam transport and emittance
 - transverse wakefields and beam break-up
 - multi-bunch effects
- Imperfections
- Parameter optimisation

Generic Linear Collider Design

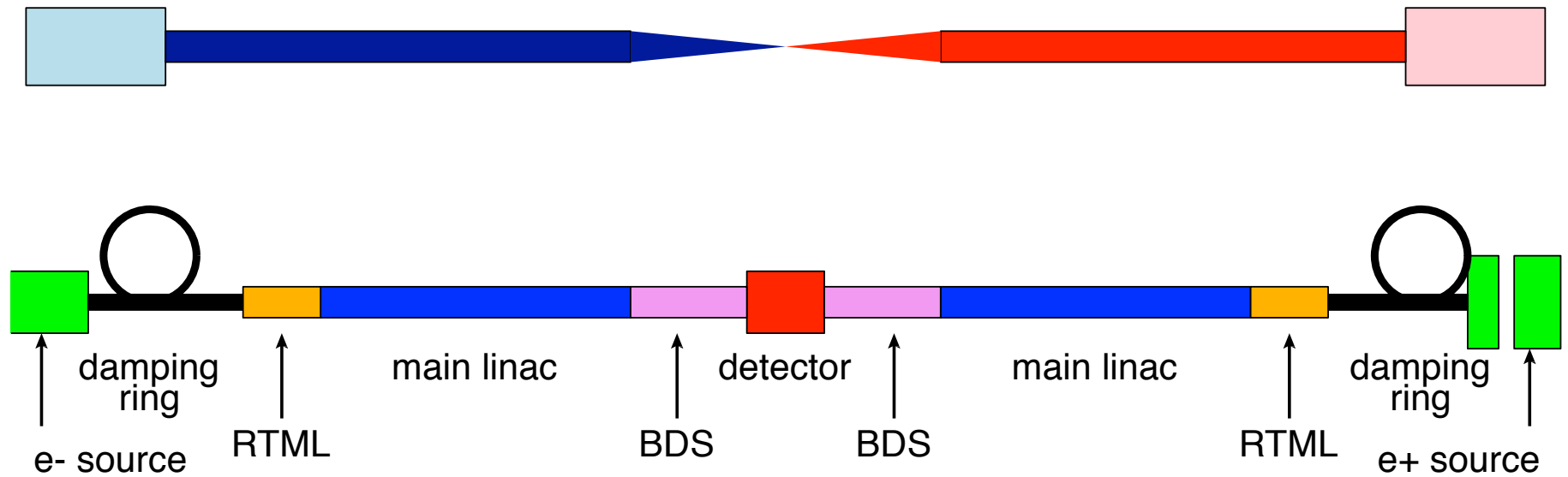

Generic FEL

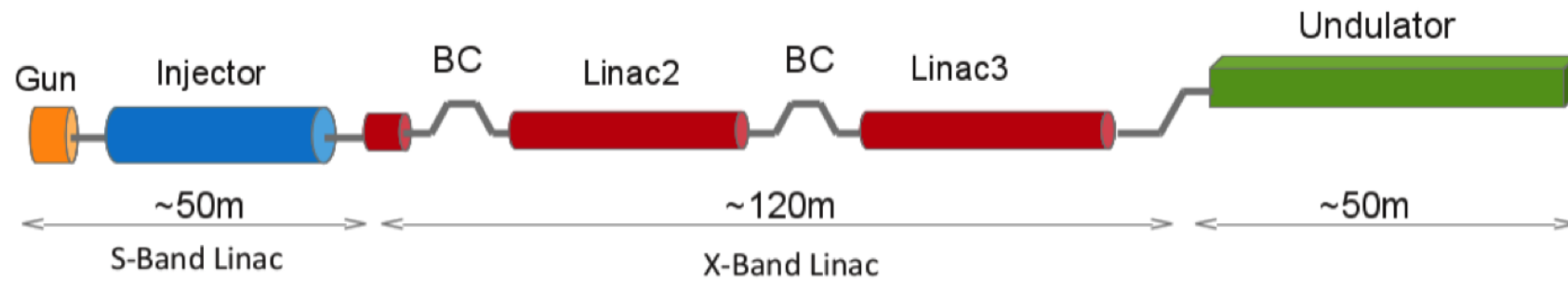

- Normal conducting FEL shown
- But superconducting similar in concept

RF Unit Design Concept (old ILC, European FEL)

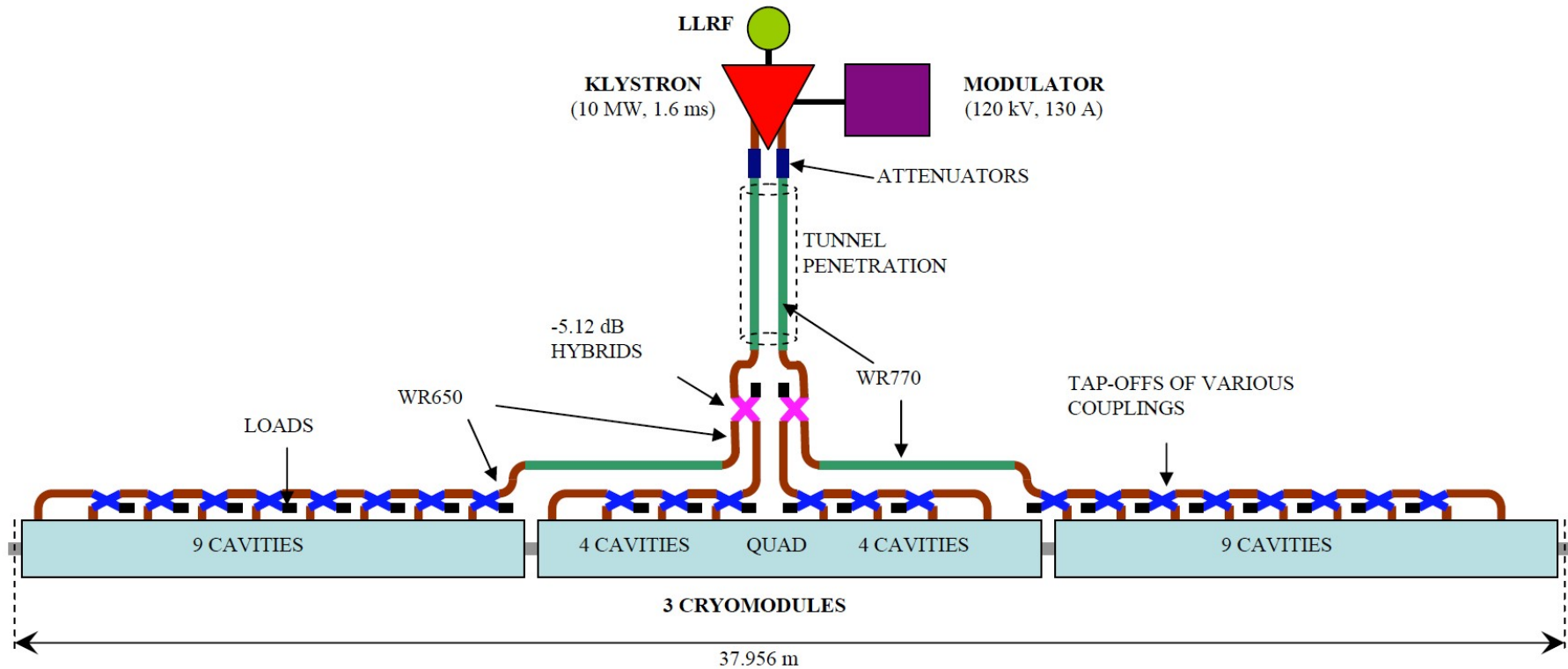

- Most relevant components for the beam
 - accelerating structures
 - quadrupoles
 - beam position monitors (BPMs) and correctors

Module Design (CLIC)

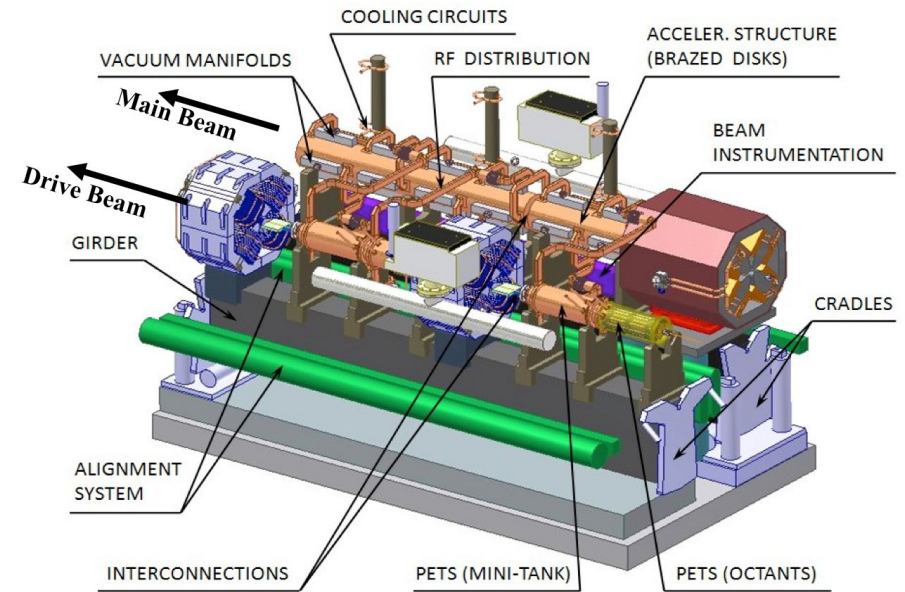
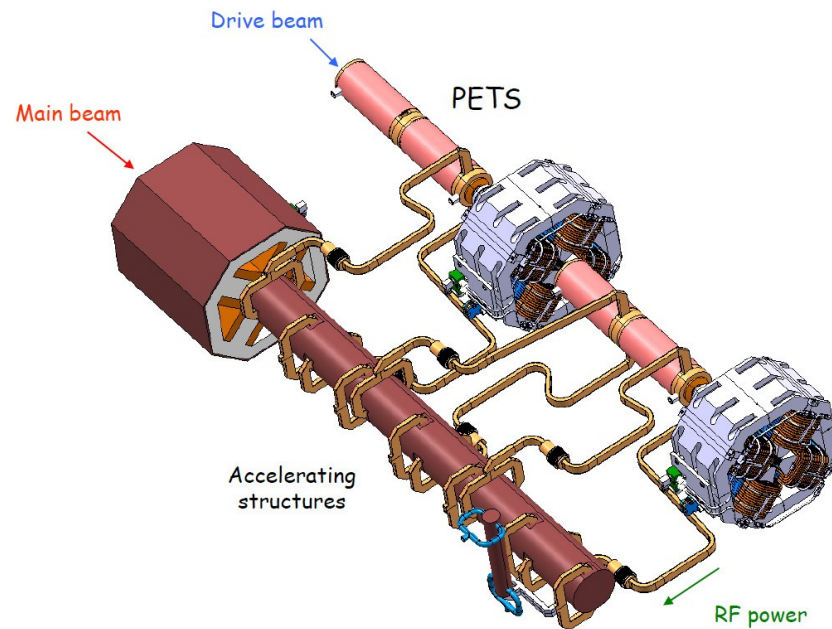

- Five types of main linac modules
- Drive beam module is regular
- Most relevant components for the beam
 - accelerating structures
 - quadrupoles
 - beam position monitors (BPMs) and correctors

Klystron-based Normal Conducting Module

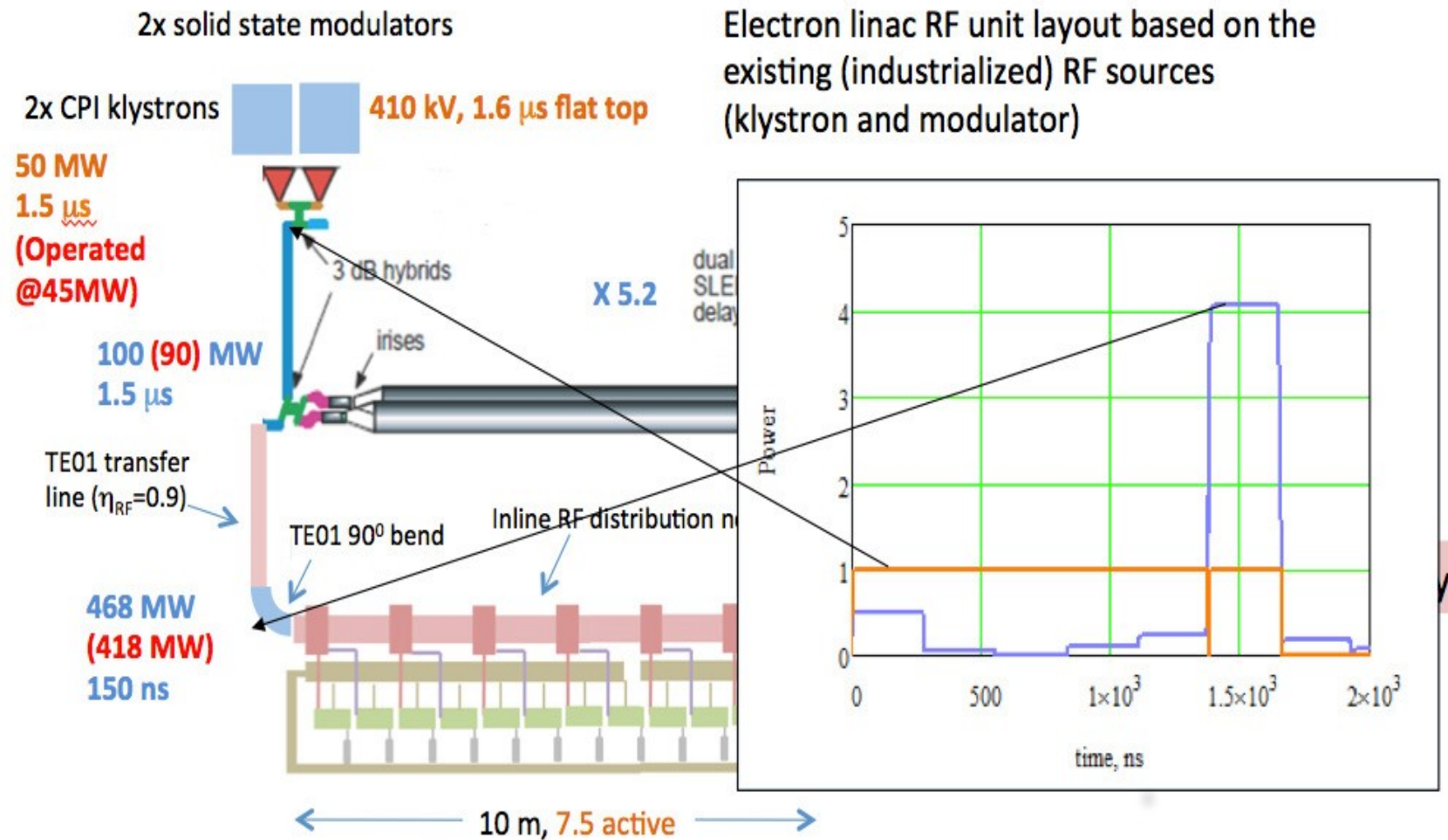

- Klystron Module for CLIC at low energy
- FEL module
 - Could use single klystron per compressor

Why is the Main Linac Important?

- In linear colliders two main parameters that are important for the physics experiments
 - collision energy
 - luminosity, a measure for the rate of events at the interaction point
- The main linac is the main component to accelerate the beam
 - ⇒ it is responsible for the beam energy
 - the main relevant parameter is the accelerating gradient
- The main linac is the main consumer of power
 - ⇒ it is an important limitation for the beam current
 - the luminosity depends on the beam current
- The main linac is one of the main sources of emittance growth
 - ⇒ the emittance is a parameter that affects the luminosity
- There is a third parameter which the main linac affects very much, the cost
 - is the society willing to pay for it?

Cost Impact

- In ILC 60% of the cost is in the ML
- The long tunnel is expensive
 - and important for the schedule (tunnel boring machines)
- The installed components are expensive
- The linac drives other machine components
 - large damping rings in ILC to be able to store the full bunch train
 - drive beam complex in CLIC
- In FELs the linacs are also important cost items, e.g. 1/3 of the SWISSFEL



Luminosity and Parameter Drivers

Can re-write normal
luminosity formula

$$\mathcal{L} = H_D \frac{N^2}{4\pi\sigma_x\sigma_y} n_b f_r$$

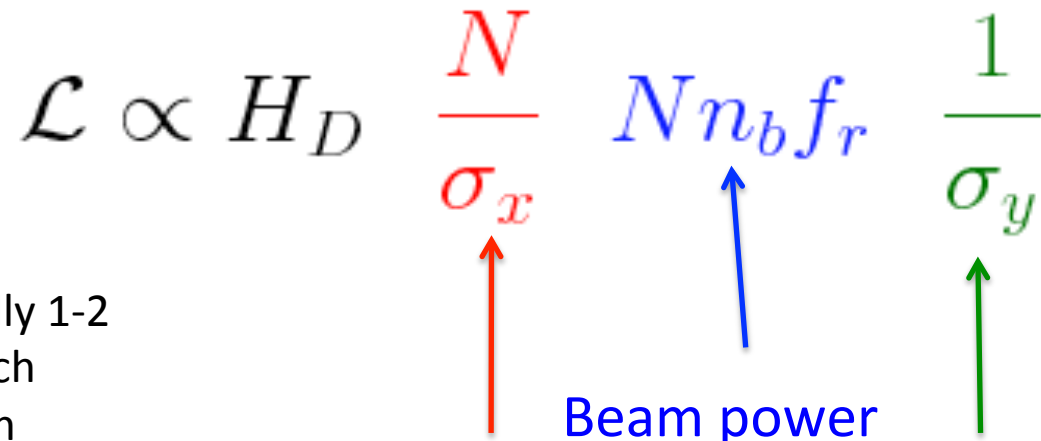
$$\mathcal{L} \propto H_D \frac{N}{\sigma_x} N n_b f_r \frac{1}{\sigma_y}$$

H_D : pinch enhancement, typically 1-2
 N : number of particles per bunch
 n_b : number of bunches per train
 f_r : number of trains per second
 $\sigma_{x,y}$: transverse beamsizes

Luminosity
spectrum

Beam power

Beam Quality
(+bunch length)

Luminosity and Parameter Drivers

In the classical regime

$$\mathcal{L} \propto H_D n_\gamma \eta_{RF \rightarrow beam} \frac{P_{RF}}{E_{cm}} \frac{1}{\sigma_y}$$

In the quantum regime

$$\mathcal{L} \propto H_D \frac{n_\gamma^{3/2}}{\sqrt{\sigma_z}} \eta_{RF \rightarrow beam} \frac{P_{RF}}{E_{cm}} \frac{1}{\sigma_y}$$

$$\sigma_y = \sqrt{\beta_y \epsilon_y / \gamma}$$

Some Fundamental Parameters

Parameter	Symbol [unit]	SLC	ILC	CLIC	CLIC
Centre of mass energy	E_{cm} [GeV]	92	500	380	3000
Luminosity	L [$10^{34}\text{cm}^{-2}\text{s}^{-1}$]	0.0003	1.8	1.5	6
Luminosity in peak	$L_{0.01}$ [$10^{34}\text{cm}^{-2}\text{s}^{-1}$]	0.0003	1	0.9	2
Gradient	G [MV/m]	20	31.5	72	100
Particles per bunch	N [10^9]	37	20	5.2	3.72
Bunch length	σ_z [μm]	1000	300	70	44
Collision beam size	$\sigma_{x,y}$ [nm/nm]	1700/600	474/5.9	143/2.9	40/1
Vertical emittance	$\varepsilon_{x,y}$ [nm]	3000	35	30	20*
Bunches per pulse	n_b	1	1312	352	312
Bunch distance	Δz [mm]	-	554	0.5	0.5
Repetition rate	f_r [Hz]	120	5	50	50

⇒ Beam Parameters are very different

- We will see that this is driven by the main linac

Accelerating Structures



Accelerating Structure (ILC)

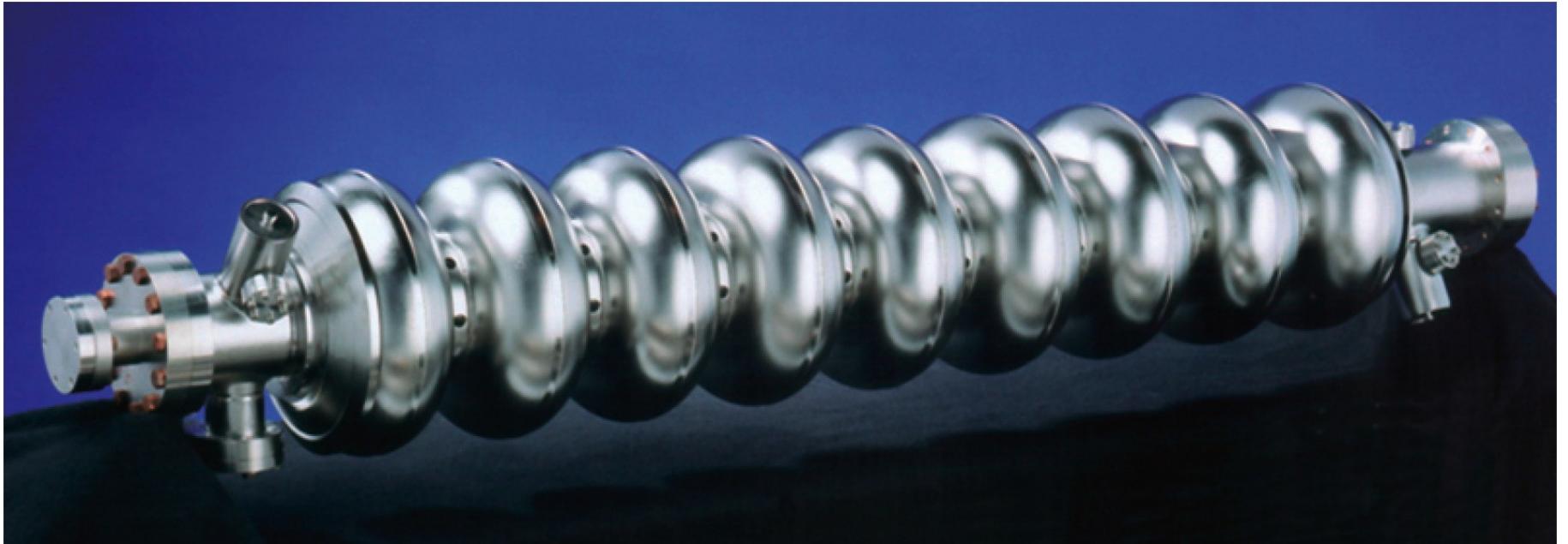

- About 1 m long cavity with 31.5 MV/m,
 - super-conducting
 - 1.3 GHz
 - standing wave
 - constant impedance

Accelerating Structure (CLIC)

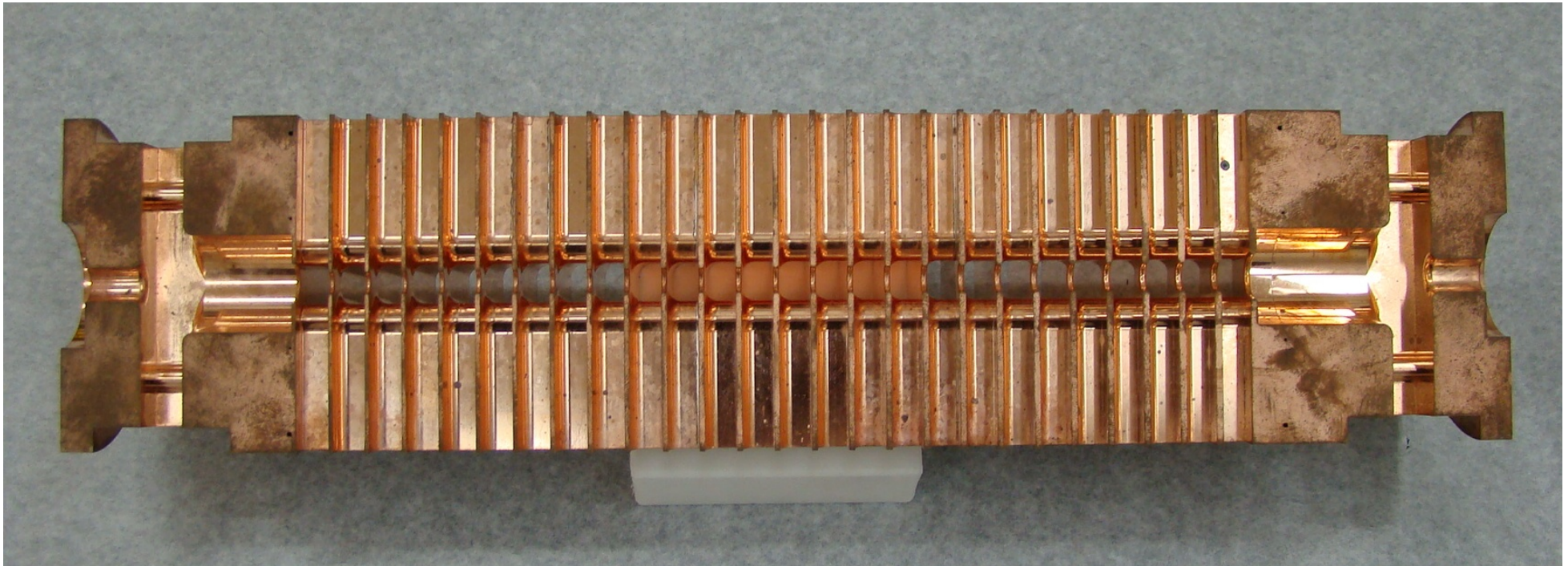

- About 23 cm long structure with $G = 100$ MV/m
 - normal-conducting
 - 12 GHz
 - travelling wave
 - constant gradient (almost)

Types of Structures

- Accelerating structures can be normal-conducting or superconducting
 - in a superconducting structure very little power is lost in the walls
 - In a normal-conducting structure a significant power is lost in the walls (in most cases)
- They can be standing wave or travelling wave structures
 - In standing wave the energy is trapped and the RF wave is reflected at the ends creating the standing wave
 - In a travelling wave structure power is coupled into one end and extracted at the other
- They can be constant impedance structures or constant gradient structures (or something else)
 - all cells can be the same design or the design differs along the structure

Choice of Material

- The material is the most fundamental design choice
- Super-conducting structures
 - allow a small beam current
 - ⇒ low background per unit time in IP
 - ⇒ intra-pulse feedback is possible everywhere
- Normal conducting structures
 - allow for high gradient
 - ⇒ high centre-of-mass energy
 - need high beam current
 - ⇒ significant wakefield effects
 - use short pulses
 - ⇒ smaller damping ring

Standing Wave Structures

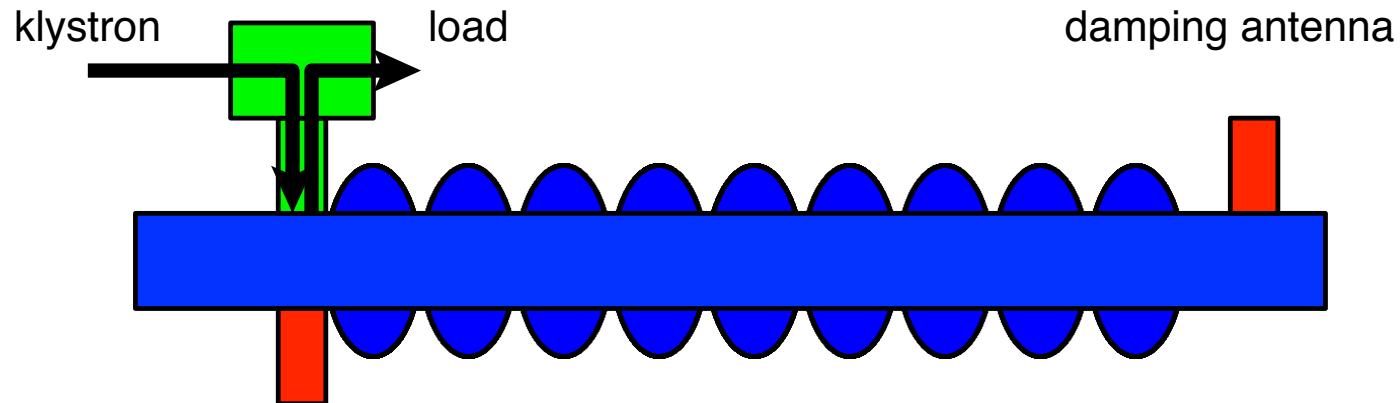

- The power is feed into one end
 - the power is reflected at the coupler
 - as the power in the cavity is increasing, the reflection is reduced
- there is a level when there is no reflection
 - ⇒ now switch on the beam

Standing Wave Structures

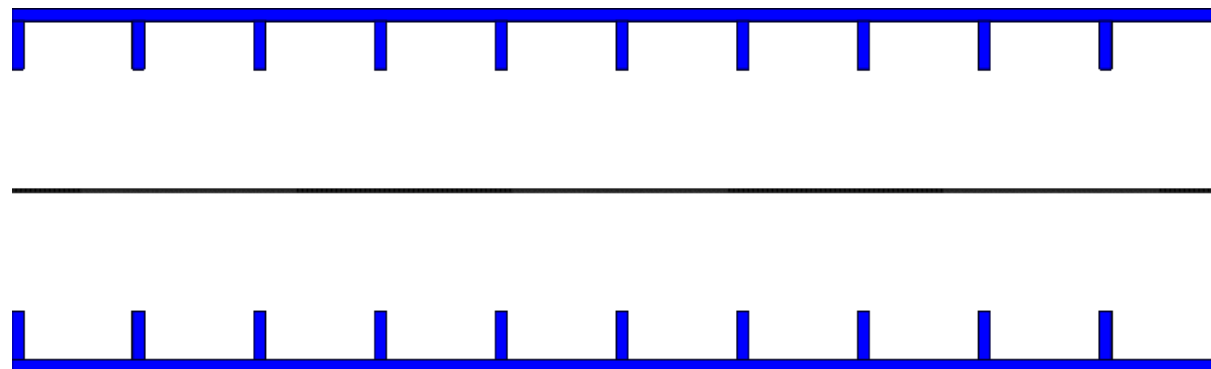
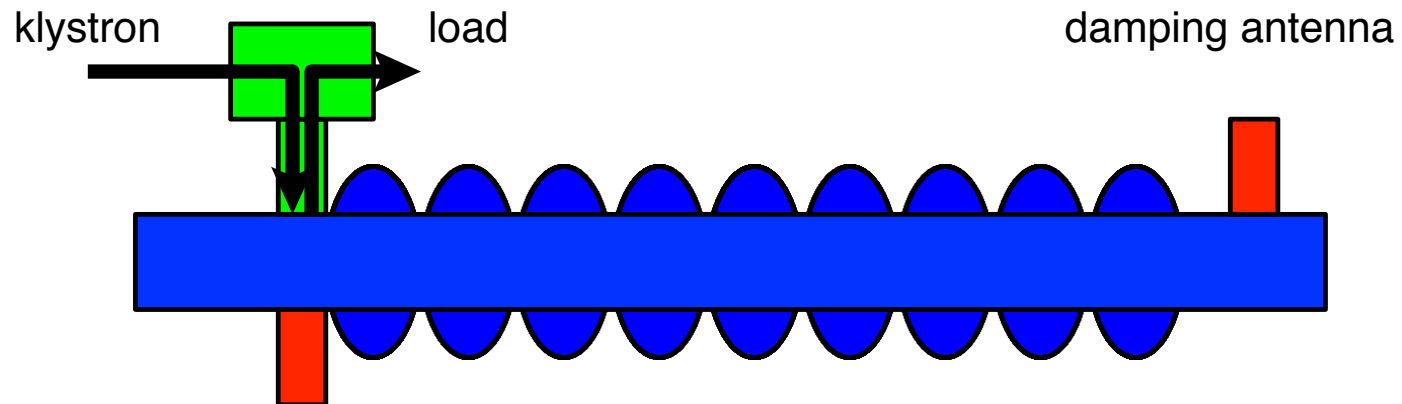

Standing Wave Structures

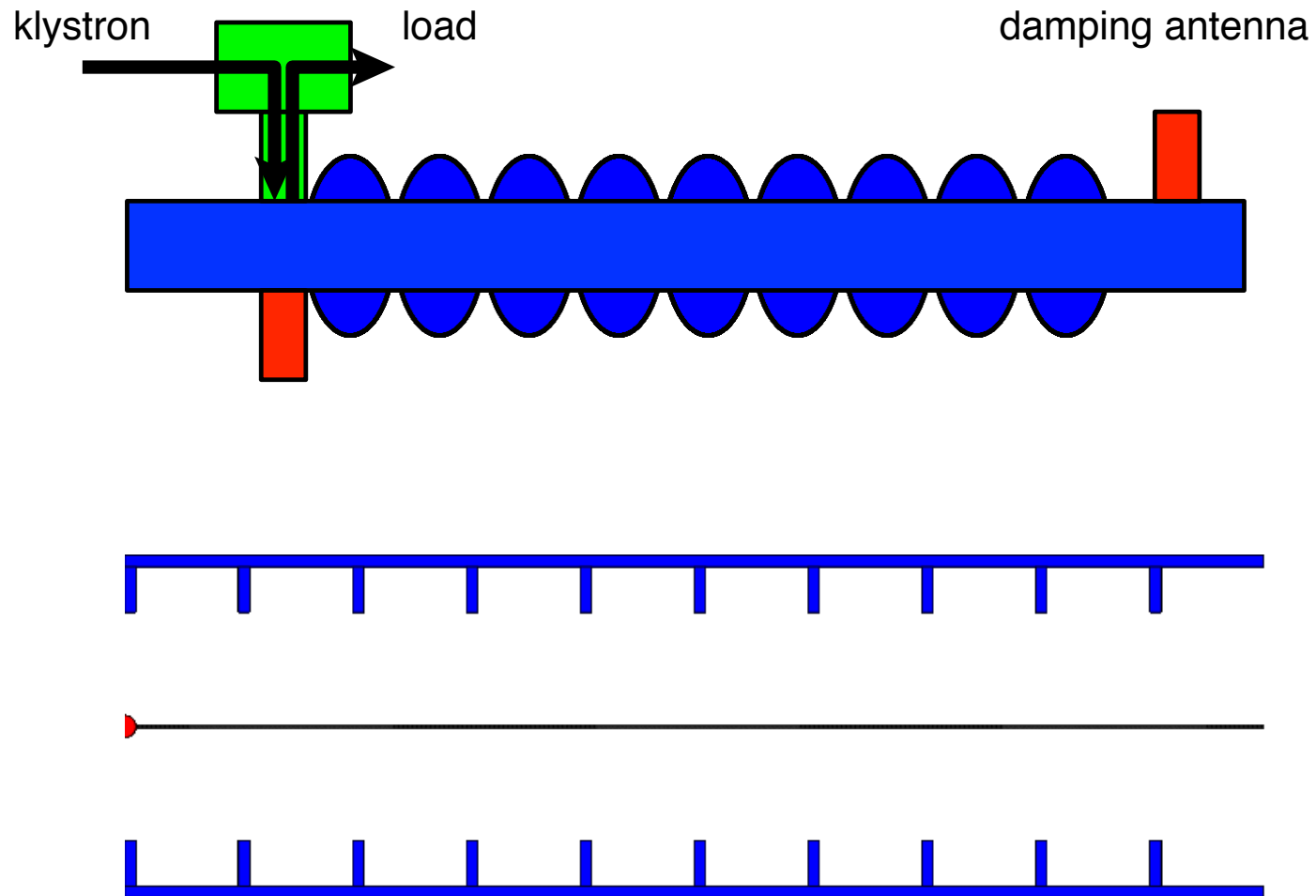

Travelling Wave Structures

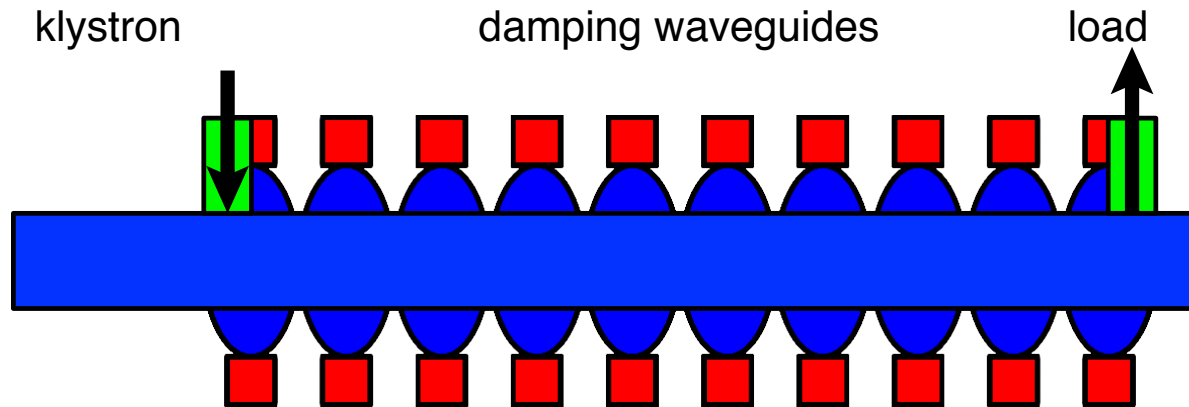

- The power is feed into one end
 - no reflection if designed properly
- It slowly moves through the structure
 - group velocity is typically a few percent of the speed of light

Travelling Wave Structures

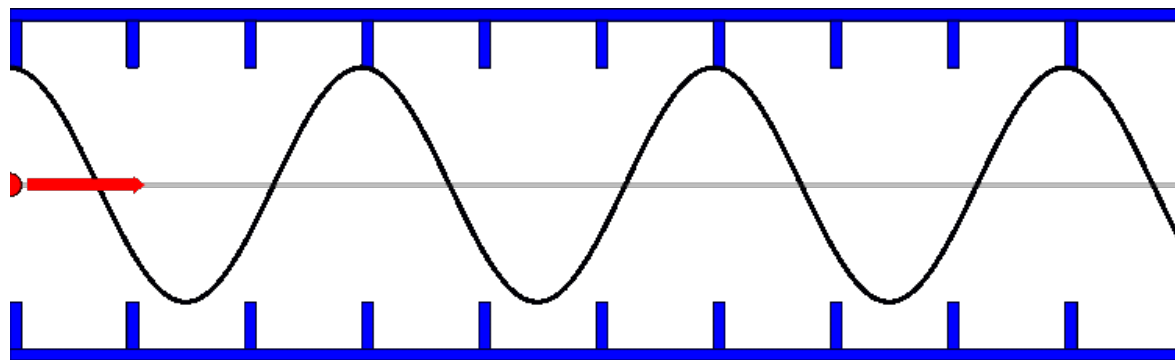
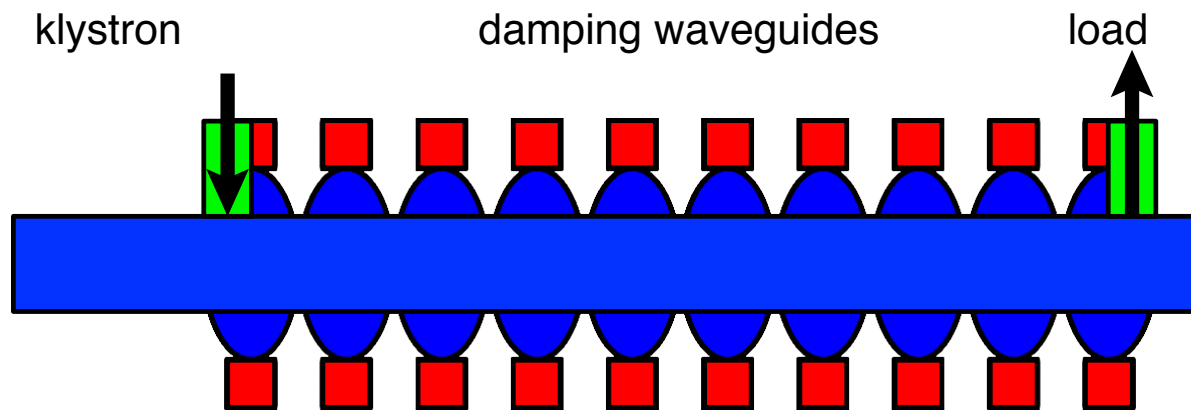

Choice of Structure Design

- In a super-conducting structure little power is lost in the wall
 - so can afford a small beam current
 - little power is extracted but over long times
 - natural choice is standing wave structures, to avoid all the power draining out at the end
 - no need to compensate extraction of energy along the structure
- For a normal conducting structure all four options (constant impedance/constant gradient and standing/travelling wave) could be used
 - for CLIC travelling wave, constant gradient structures have been chosen
 - travelling wave structures avoid recirculators to keep the energy in the structures
 - constant gradient allows to reach higher effective gradients

Choice of Frequency

- Obviously the frequency choice differs
 - CLIC: 12 GHz
 - ILC: 1.3 GHz
- So what drives the choice?
- ILC uses super-conducting structures
 - high frequencies lead to higher surface resistance
 - high frequencies lead to higher wakefield amplitudes $W_L \propto f^2$, $W_{\perp} \propto f^3$
 - a very low frequency makes the structures expensive (dimension $\propto \lambda$)

⇒ so a frequency with existing power sources has been picked
- CLIC uses normal-conducting structures
 - higher frequencies help in reaching high gradients
 - but also lead to higher wakefields

⇒ full optimisation of the design has been performed to achieve the lowest cost for a fixed energy and luminosity target

RF Power Generation



Klystron

- Usually the input RF power for the accelerating structures is provided by klystrons
- In ILC or superconducting FELs klystrons are used to directly power the main beam
- In CLIC they power the drive beam accelerator
 - only at low energy could use them in the main linac

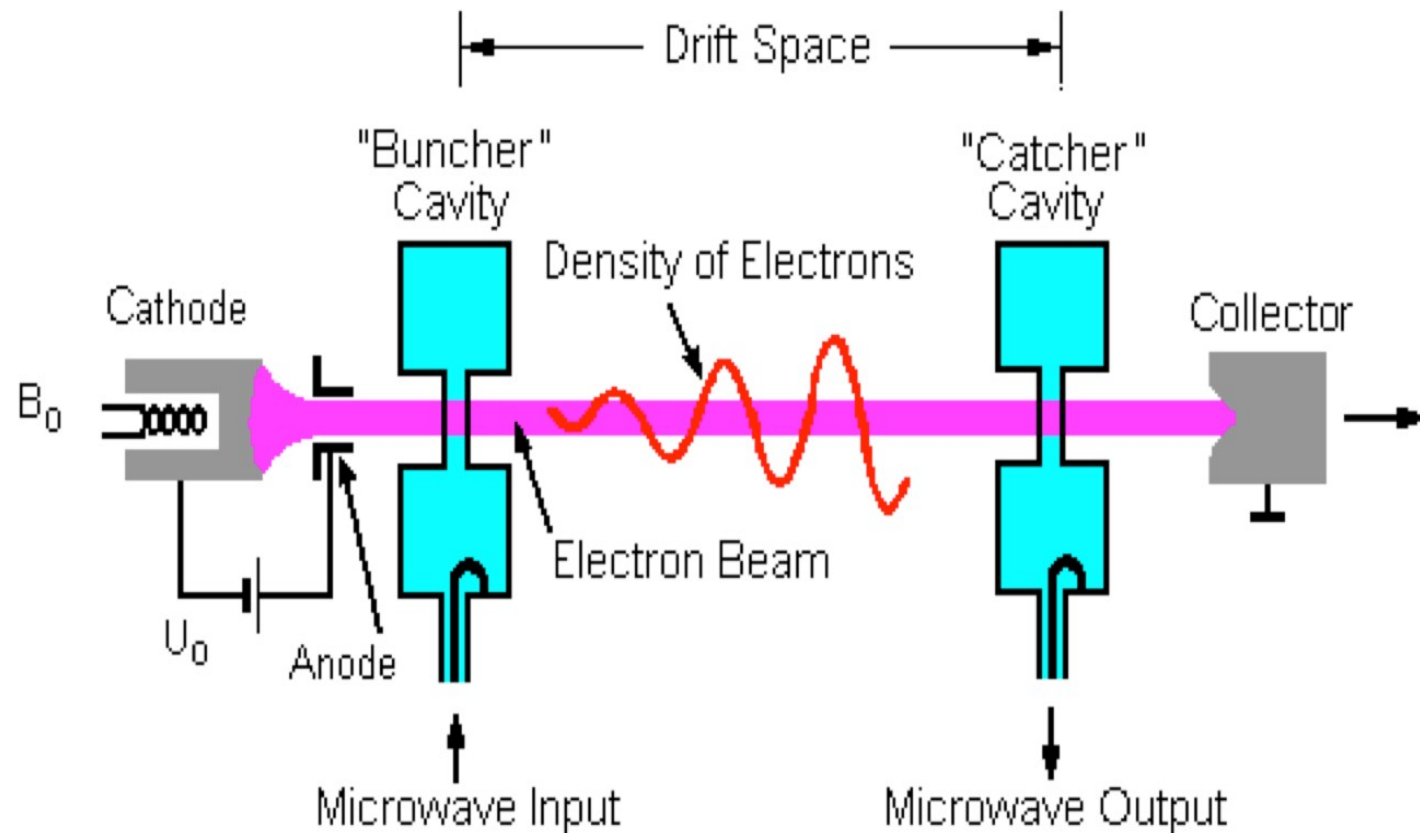

- In normal conducting FEL would use klystrons and pulse compressors
- Klystrons tend to be more efficient at low frequencies and long pulses

Power Needs

	ILC ML	CLIC ML	CLIC DB
Peak power/structure [MW]	0.2	61.3	20
Structures	16,000	140,000	1100
Total peak power [GW]	3	8,600	22
Pulse length [μ s]	1,600	0.244	142

Note: Numbers are rounded, new CLIC drive beam numbers used

- Main cost drivers are peak power, average power and energy per pulse
 - the first make the klystron tough
 - the second the modulators
- Very short high peak power for CLIC main linac would be very expensive
 - ⇒ hence the drive beam scheme with reasonable klystron peak power
- For ILC and CLIC drive beam average power is important for cost
 - but there is nothing we can do to reduce it if we do not want to compromise luminosity
 - ILC klystrons: 1.3 GHz, 5×1.5 ms at 10 MW
 - CLIC drive beam klystrons: 1 GHz, 50×140 μ s at 20 MW

Drive Beam (CLIC)

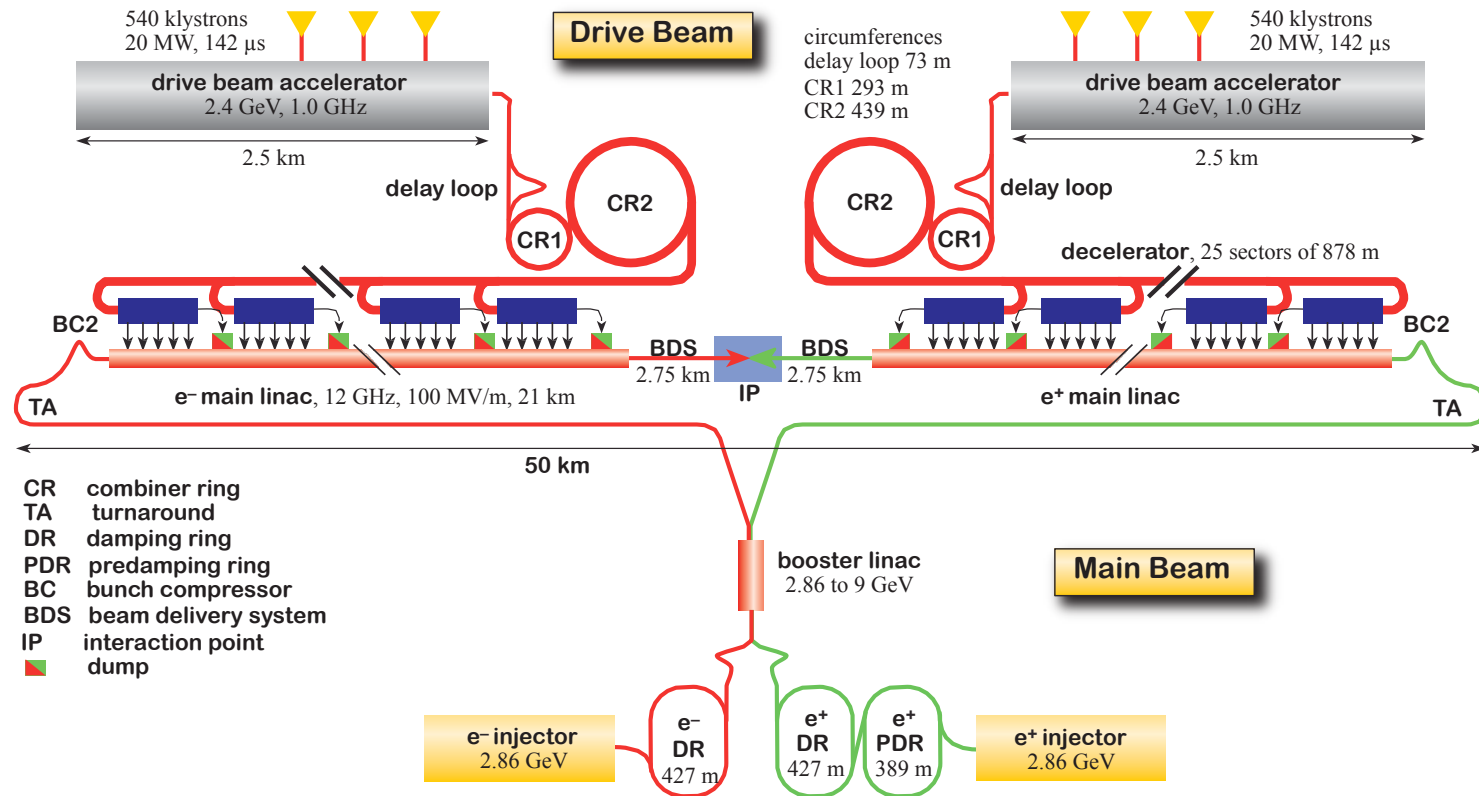

- Can see the CLIC drive beam complex as a single huge klystron
 - with a fancy pulse compression

Power Efficiency



Coordinate Systems

- We use two frames, the laboratory frame and the beam frame
- The nominal direction of motion of the beam is called s in the laboratory frame, the beam moves toward increasing s
- The longitudinal direction is called z in the beam frame, with particles at smaller z moving ahead of particles with larger z
- A particle preserves its longitudinal position within the beam
- The transverse dimensions are x in the horizontal and y in the vertical plane, in both coordinate systems
- People use different systems so find out what they talk about

Beam Power

- Power consumption of the main linac is a prime consideration
 - electricity cost
 - equipment cost
- Examples of total beam power
 - ILC: $P_{beam} = 2n_b f_r N E \approx 11 \text{ MW}$
 - CLIC: $P_{beam} \approx 28 \text{ MW}$
- Wall plug power can be transformed into RF power with limited efficiency
- The efficiency of transforming RF power into beam power depends on
 - structure design
 - the gradient
 - the beam parameters
- The structures need to be cooled (especially in a super-conducting machine)

RF to Beam Power Efficiency

The RF to beam efficiency can be calculated looking at a single structure/cavity during the RF pulse

- Efficiency is

$$\eta_{RF \rightarrow beam} = \frac{\text{Energy taken by one beam pulse}}{\text{Energy in each RF pulse}}$$

Assuming constant RF pulse power we can calculate

$$\eta_{RF \rightarrow beam} = \frac{\tau_{beam}}{\tau_{RF}} \cdot \frac{P_{beam}}{P_{RF}}$$

P_{beam} is the power going into the beam during the beam pulse, P_{RF} is the RF power during the RF pulse

We simplify

$$\eta_{RF \rightarrow beam} = \frac{\tau_{beam}}{\tau_{beam} + \tau_{fill}} \cdot \frac{P_{beam}}{P_{beam} + P_{loss} + P_{out}}$$

Note: what I call τ_{fill} contains several components of which the fill time is the most important; RF experts will learn more

RF to Beam Power Efficiency

$$\eta_{RF \rightarrow beam} = \frac{\tau_{beam}}{\tau_{beam} + \tau_{fill}} \cdot \frac{P_{beam}}{P_{beam} + P_{loss} + P_{out}}$$

- In a super-conducting cavity
 - little RF power is lost in the walls during the pulse
 - but the cooling requires some significant overhead
 - some cooling is also needed against heating from the environment

$$\eta_{RF \rightarrow beam} = \frac{\tau_{beam}}{\tau_{beam} + \tau_{fill}}$$

- In normal conducting structures
 - A significant fraction of the RF power is lost into the walls
 - some power will be draining out of the travelling wave structure (usually)

$$\eta_{RF \rightarrow beam} = \frac{\tau_{beam}}{\tau_{beam} + \tau_{fill}} \cdot \frac{P_{beam}}{P_{beam} + P_{loss} + P_{out}}$$

Shunt Impedance R and P_{loss}

Note: the concept of shunt impedance will be important for all efficiency effects

The field in a structure induces losses in the walls

The loss is described by R , the shunt impedance, defined as

$$R = \frac{\text{effective voltage}^2}{\text{ohmic power loss}} = \frac{V^2}{P_{loss}} = \frac{(GL)^2}{P_{loss}}$$

Note: the impedance is here given in “Linac Ohms” , in “Circuit Ohms” the number would be only 50%: 1”Linac Ohm”= 0.5”Circuit Ohm”

So one obtains easily the power

$$P_{loss} = \frac{(GL)^2}{R}$$

⇒ High R means little losses

Losses vs. Acceleration

Power loss per unit length in the wall

$$P'_{loss} = \frac{G^2}{R'}$$

Power per unit length given to the beam

$$P'_{beam} = IG$$

R' is shunt impedance per unit length
The ratio is

$$\frac{P'_{beam}}{P'_{loss}} = R' \frac{I}{G}$$

⇒ For high efficiency want

- lower gradient G
- higher current I
- higher shunt impedance R'

- The average beam current is determined by the luminosity goal
- The machines are pulsed to increase the beam current while the RF is on
- So what limits the shunt impedance and the beam current?

Shunt Impedance

The shunt impedance R depends on three main factors

- structure geometry
- structure material
- RF frequency

The energy stored in the structure is only a function of the geometry

- all energy is in the vacuum
- described by R/Q (and ω)

The rate of losses depends on the surface material, the shape and the RF frequency

- material is most important
- described by Q

Hence, the value of R can be written as

$$R = \frac{R}{Q} Q$$

Stored Energy R/Q

- We can simply calculate R/Q

$$R = \frac{\text{effective voltage}^2}{\text{ohmic power loss}} = \frac{(GL)^2}{P_{loss}}$$

$$Q = \frac{\text{stored energy}}{\text{ohmic energy loss per radian of RF circle}} = \frac{E}{P_{loss}}\omega$$

- Hence

$$(R/Q) = \frac{(GL)^2}{P_{loss}} \frac{P}{E\omega} = \frac{(GL)^2}{E\omega}$$

so one can calculate

$$E = \frac{(GL)^2}{(R/Q)\omega}$$

⇒ The structure geometry defines R/Q and does not depend on the material

Remark: Scaling of R/Q

The structure geometry defines

$$\left(\frac{R}{Q}\right) = \frac{(GL)^2}{E\omega}$$

Energy in the structure (same gradient) scales with the volume

$$E \propto \lambda^3$$

the energy gain GL scales with

$$GL \propto \lambda$$

and the frequency ω as

$$\omega = 1/\lambda$$

Hence

$$\Rightarrow \frac{R}{Q} = \frac{(GL)^2}{E} \frac{1}{\omega} \propto \frac{\lambda^2 \lambda}{\lambda^3 1} = \text{const}$$

A typical value for superconducting cavities is 110Ω per cell

Quality Factor Q

- The internal quality factor Q (here the same as Q_0) is defined as

$$Q = \frac{\text{stored energy}}{\text{ohmic energy loss per radian of RF circle}} = \frac{E}{P_{loss}} \omega$$

this allows to easily write the decay of the energy due to ohmic losses

$$E(t) = E_0 \exp(-\omega t/Q)$$

⇒ High Q indicates little losses

Example values are

- $O(10^{10})$ for superconducting
 - $O(10^4)$ for normal conducting structures
- Scaling is
 - $\propto \omega^{-2}$ for superconducting structures (but upper limit from other resistivity)
 - $\propto \sqrt{\omega^{-1}}$ for normal conducting structures

Required RF Pulse Length (Outdated Numbers)

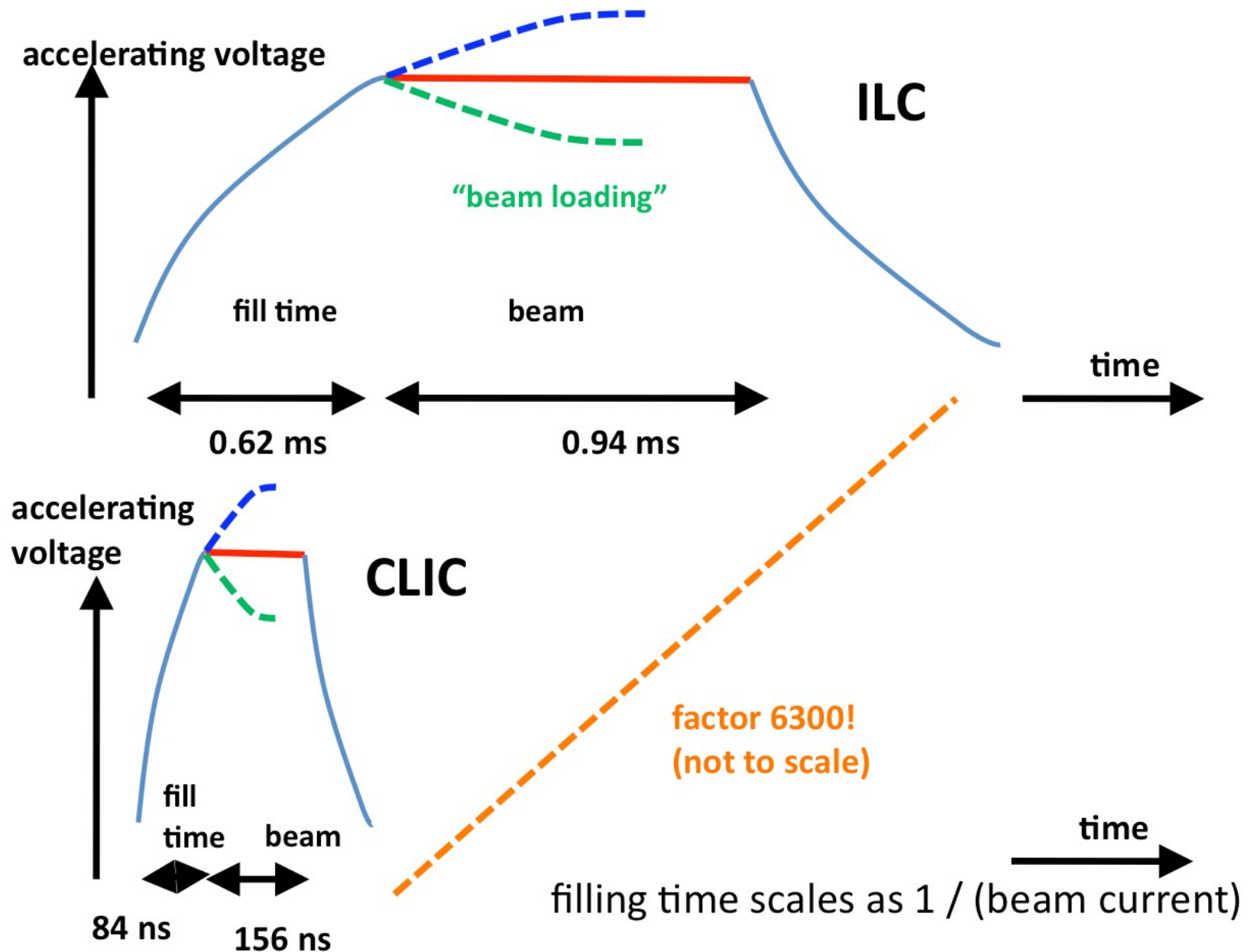

Filling a Standing Wave Cavity

- Once filled, the energy should be kept in the cavity

⇒ can only allow little coupling to the outside, i.e. large Q_E

$$E(t) = E(t_0) \exp\left(-\frac{t - t_0}{Q_E} \omega\right) \quad G(t) = G(t_0) \exp\left(-\frac{t - t_0}{2Q_E} \omega\right)$$

⇒ RF power sent to the structure can be reflected

⇒ So we need to match the coupling to have no reflection at nominal gradient

- First we chose the input power to correspond to the power extracted by the beam (neglecting losses in the wall)

$$P_{in} = G_{target} L I_{beam}$$

Filling a Standing Wave Cavity (cont.)

- Now we determine the required coupling Q_E

The reflected voltage for input power P_{in} is given by

$$V_{refl} = \sqrt{aP_{in}}$$

The stored energy causes a power flow in direction of the reflected wave

$$P_{cavity} = \frac{E\omega}{Q_E}$$

This causes a field outside of the coupler iris

$$V_{out} = -\sqrt{aP_{out}}$$

This yields the voltage for the load V_{load} :

$$V_{load} = V_{refl} + V_{out} = \sqrt{aP_{in}} - \sqrt{a\frac{E_{target}}{Q_E}\omega}$$

In order to have no power going to the load we require

$$\begin{aligned} V_{load} &= 0 \\ \Rightarrow P_{in} &= P_{out} = \frac{E_{target}}{Q_E}\omega \\ \Rightarrow Q_E &= \frac{E_{target}}{P_{in}}\omega \end{aligned}$$

Filling a Standing Wave Cavity (cont.)

- Now we calculate the fill time

To simplify, we define

$$t_c = \frac{E_{target}}{P_{in}}$$

We will not go through the calculation here but present the result

The gradient in the structure is given by

$$G = 2G_{target} \left(1 - \exp\left(-\frac{t}{2t_c}\right) \right)$$

Hence the target gradient is reached after the fill time t_{fill} :

$$t_{fill} = \ln(4)t_c$$

Filling A Travelling Wave Cavity

- In a travelling wave, normal conducting structure the fill time is the time for an energy to flow from input coupler to output coupler
 - in principle need to add rise time (but for RF experts)
- ⇒ get your number from the RF expert
- We will discuss the wakefield view of the beam loading to understand
 - reason for output power
 - beam loading compensation

Passage of a Particle

A particle in the structure will

- extract or leave energy (depending on energy in structure)
- induce electromagnetic wakefields
 - cosine-like Logitudinal (monopole) and sine-like transverse (dipole) modes for offset driving particles
 - The wakefield does not depend on the energy in the structure

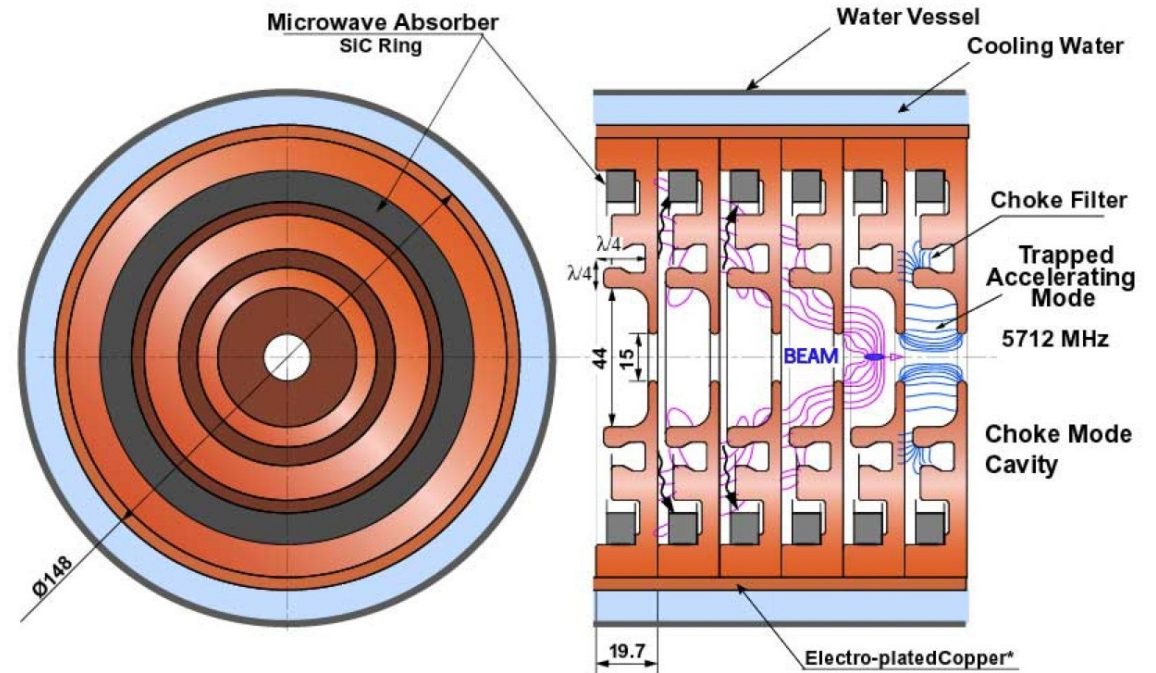

- The longitudinal wakefield $W_L(z)$ expresses the average acceleration of a particle at time z along the structure [V/mC]
- The transverse wakefield $W_{\perp}(z)$ expresses the average transverse deflection of a particle at time z along the structure [V/m^2C]

Wakefield

- The field seen by a following particle depends on the time and position along the structure

$$G_{wake}(s, z)$$

- For most purposes we average this field for the passage through the structure
- A bunch with charge Ne and transverse offset δ is followed at distance z by a witness electron

- Energy change is $\Delta P_L c \approx \Delta E = Ne W_L(z) L e$

- Transverse deflection $\Delta P_{\perp} c = Ne W_{\perp}(z) L \delta e$

- Analytic longitudinal wake for iris radius a
- Analytic transverse wake

$$W_L(z \rightarrow 0) = \frac{Z_0 c}{\pi a^2}$$

$$W_{\perp}(z \rightarrow 0) = \frac{2Z_0 c}{\pi a^4} z$$

- For larger distances one has to perform simulations

Wakefield and Power Extraction

- Why can a wakefield model be used for the beam loading?

- i.e.

$$\Delta G(q) = \text{const } q$$

- The energy stored per unit length in the accelerating structure is

$$E'(s) = \frac{G(s)^2}{(R'/Q)(s)\omega}$$

- The reduction of accelerating field due to the passing charge q is $-\Delta G(s)$
- This yields for the energy lost by the structure

$$\Delta E'_{lost}(s) = \frac{G^2(s) - (G(s) - \Delta G(s))^2}{(R'/Q)(s)\omega} \Rightarrow \Delta E'_{lost}(s) = \frac{2G(s)\Delta G(s) - (\Delta G(s))^2}{(R'/Q)(s)\omega}$$

- The beam extracts an energy

$$\Delta E'_{beam}(s) = q \left(G(s) - \frac{1}{2}\Delta G(s) \right)$$

hence

$$\begin{aligned} q \left(G(s) - \frac{1}{2}\Delta G(s) \right) &= \frac{2G(s)\Delta G(s) - (\Delta G(s))^2}{(R'/Q)(s)\omega} \\ \Rightarrow \Delta G(s) &= \frac{(R'/Q)(s)\omega}{2} q \end{aligned}$$

⇒ The gradient change depends only on the charge not the initial gradient, as expected

- Note: I simplified a bit (sorry, but this is easier with cheating)

Beam Loading in Travelling Wave Structure

- Consider constant impedance, $Q = \infty$
- Field induced by passing bunch is moving forward
 - as is external RF

⇒ beam loading fields build up along the structure
- The RF loses power in the wall

⇒ The gradient decreases along the structure

- Warning: simplified flying sausage model, not strictly correct but good for some understanding

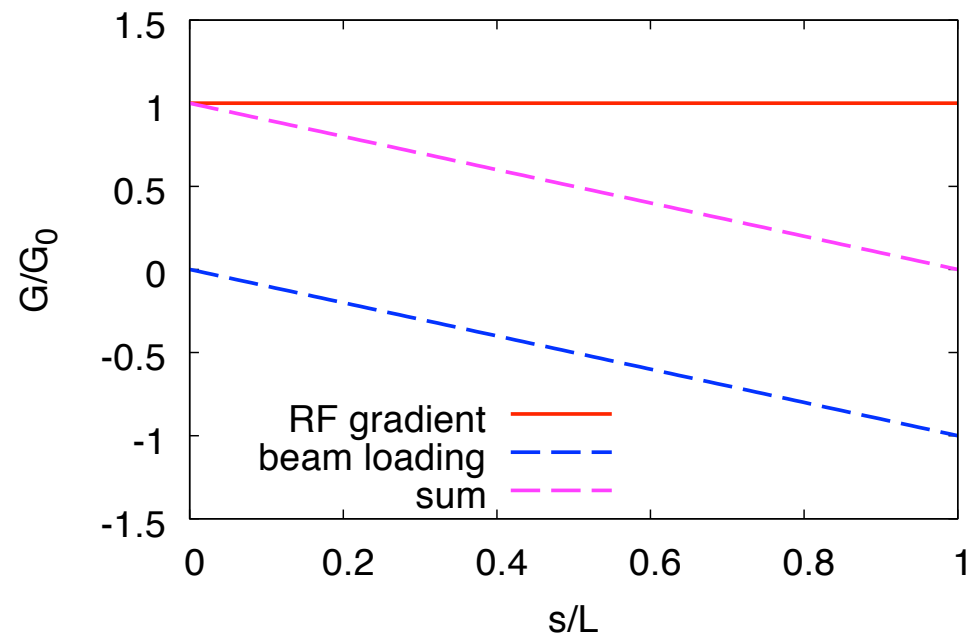
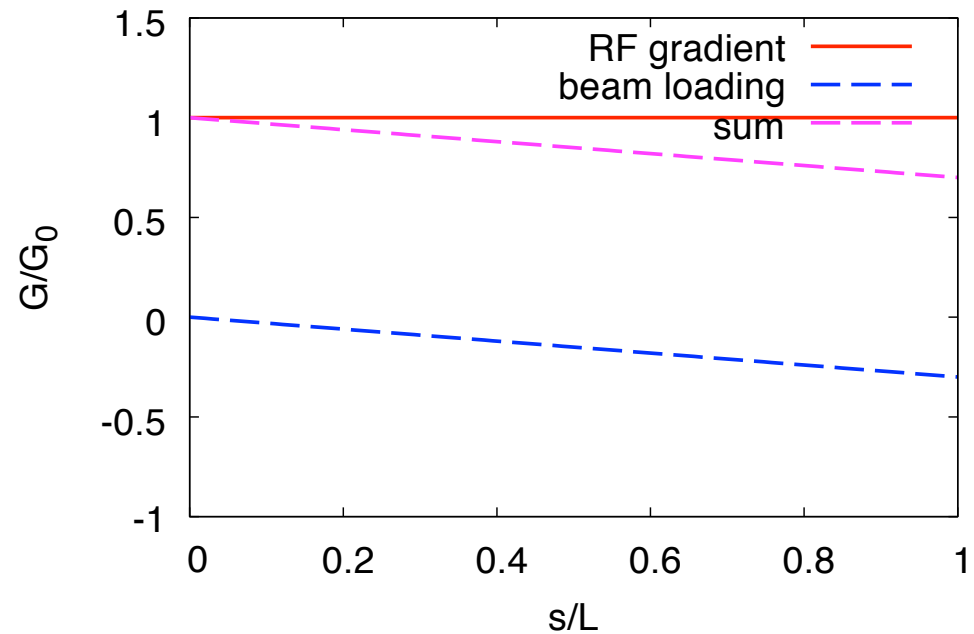

Beam Loading in Travelling Wave Structure

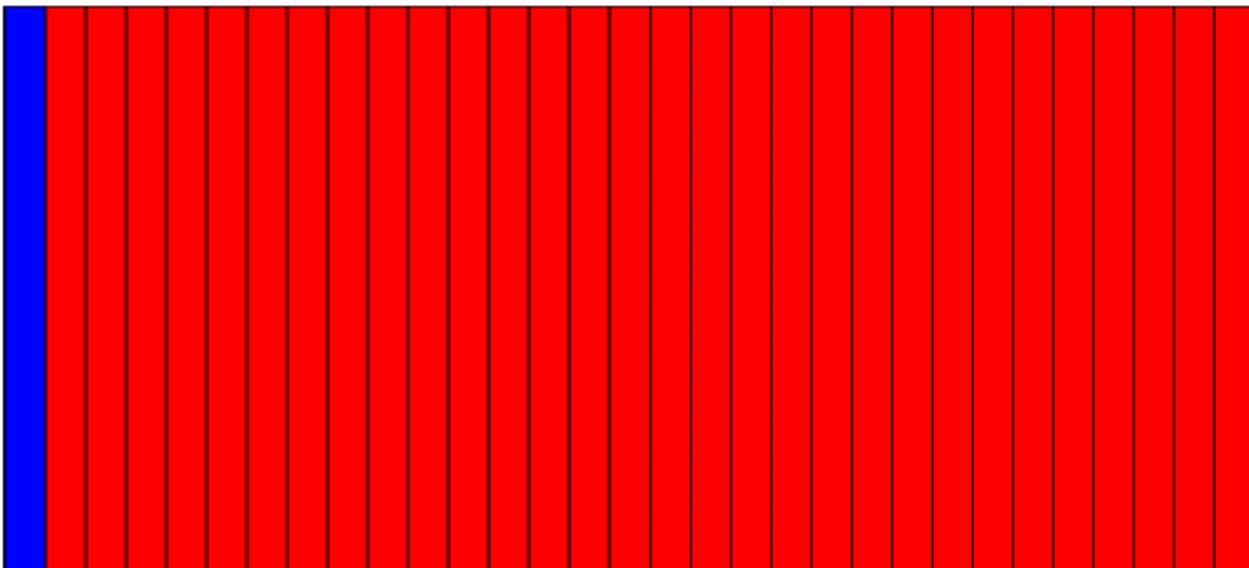
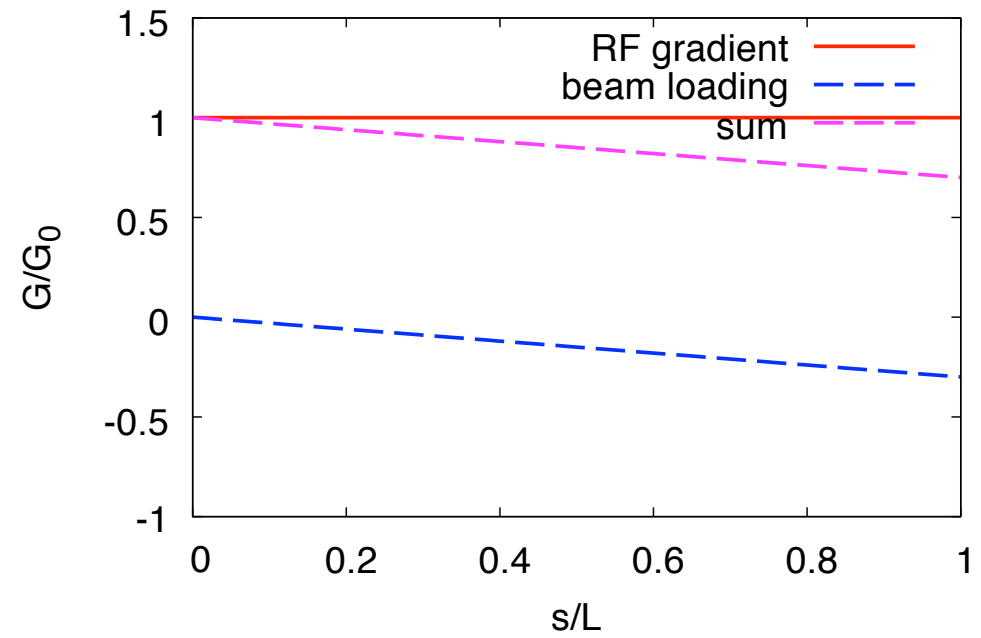

Beam Loading Compensation

- Constant impedance example with losses into the walls
 - The first bunch sees no beam loading
- ⇒ We need to shape the RF pulse accordingly

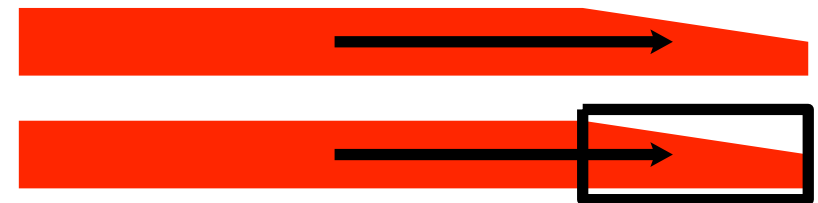
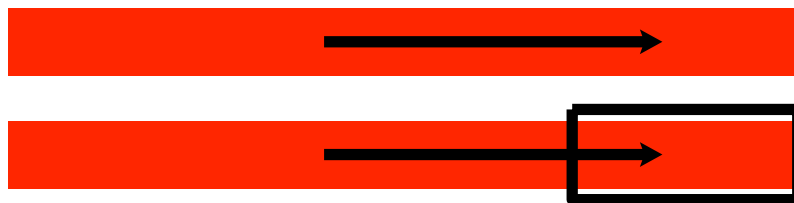
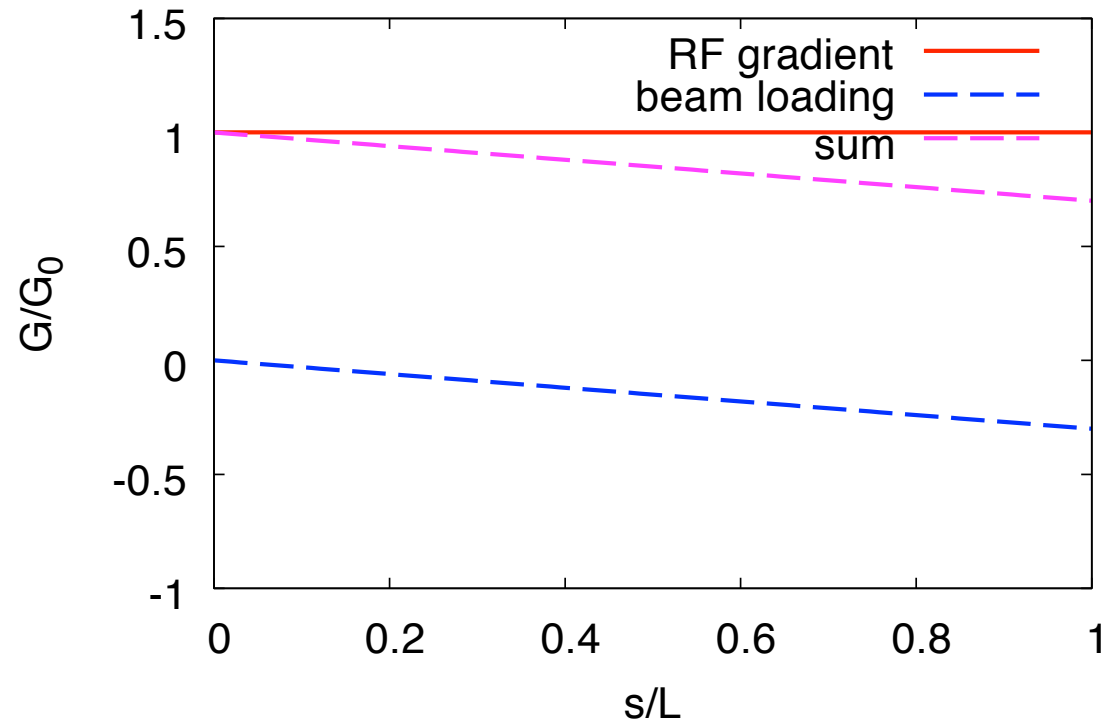

Beam Loading Compensation

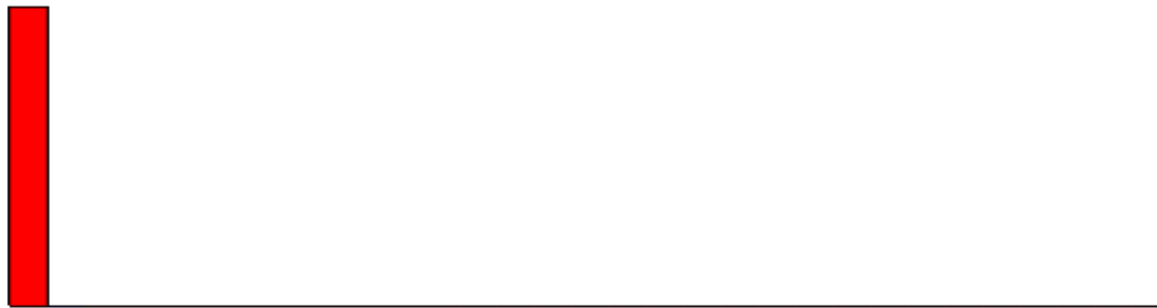

Structure Tapering

- By decreasing the along the structure iris radius the local R/Q increases
- ⇒ The unloaded gradient increases along the structure
- ⇒ The loaded gradient remains constant
- In practice we have to ensure that the RF constraints are fulfilled in each cell
- Note: beam loading could reduce breakdown rate

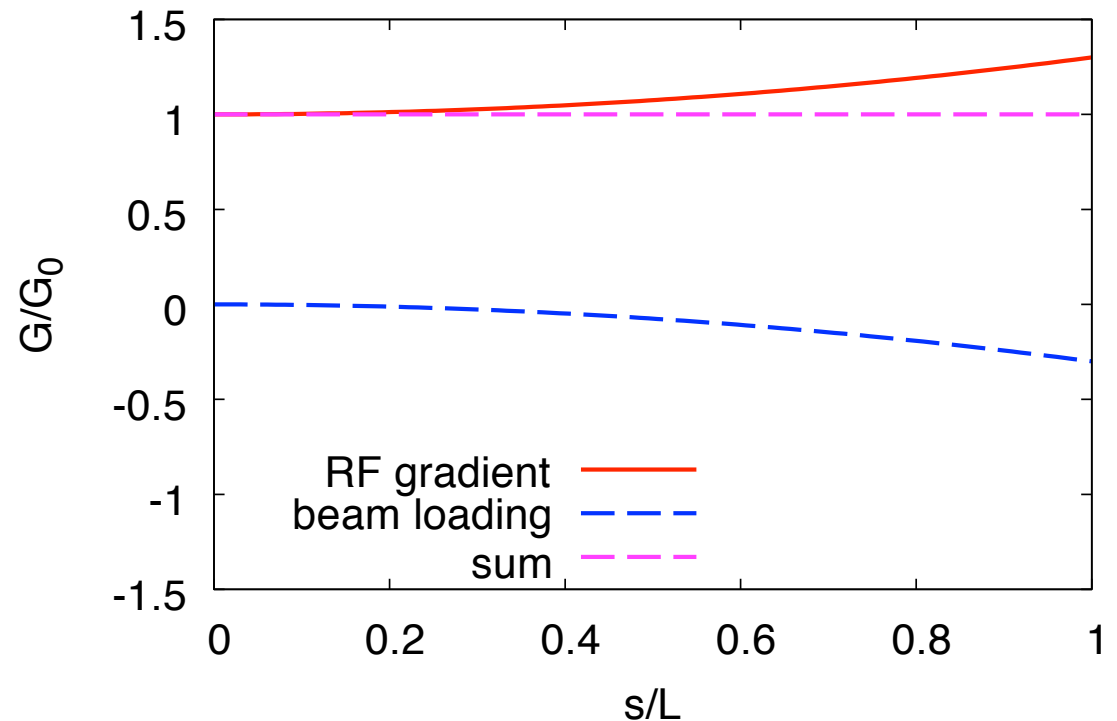

- Note: in CLIC about 20% of the RF power are lost in the loads during the flat top

Structure Tapering

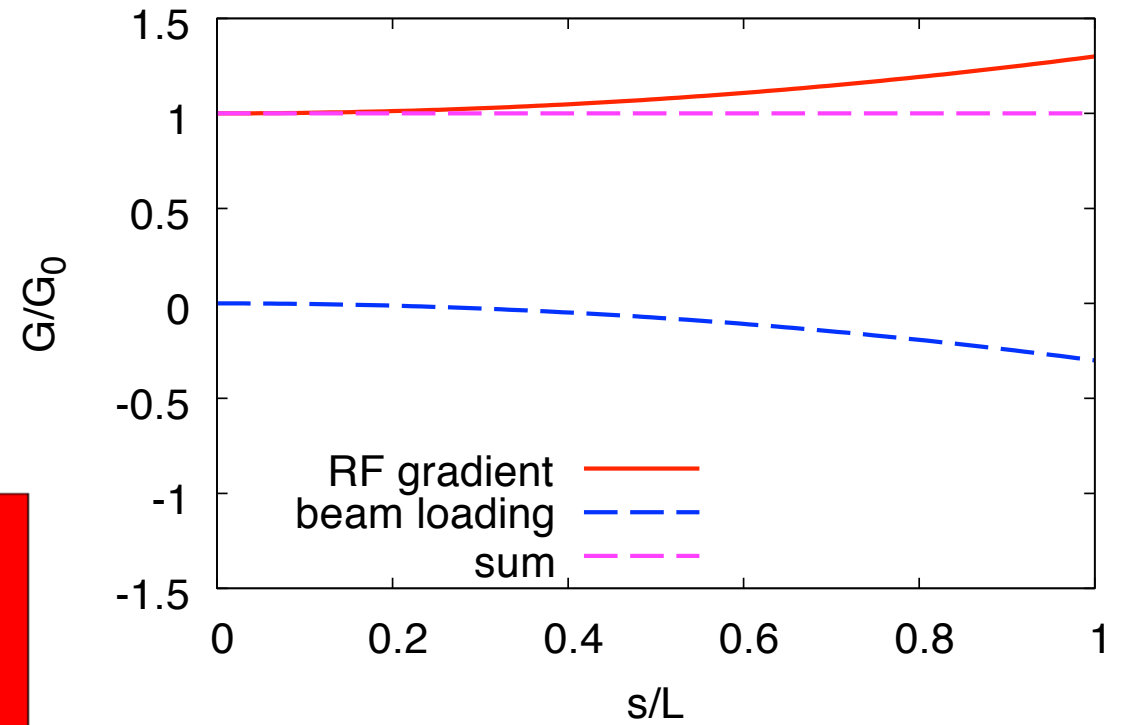
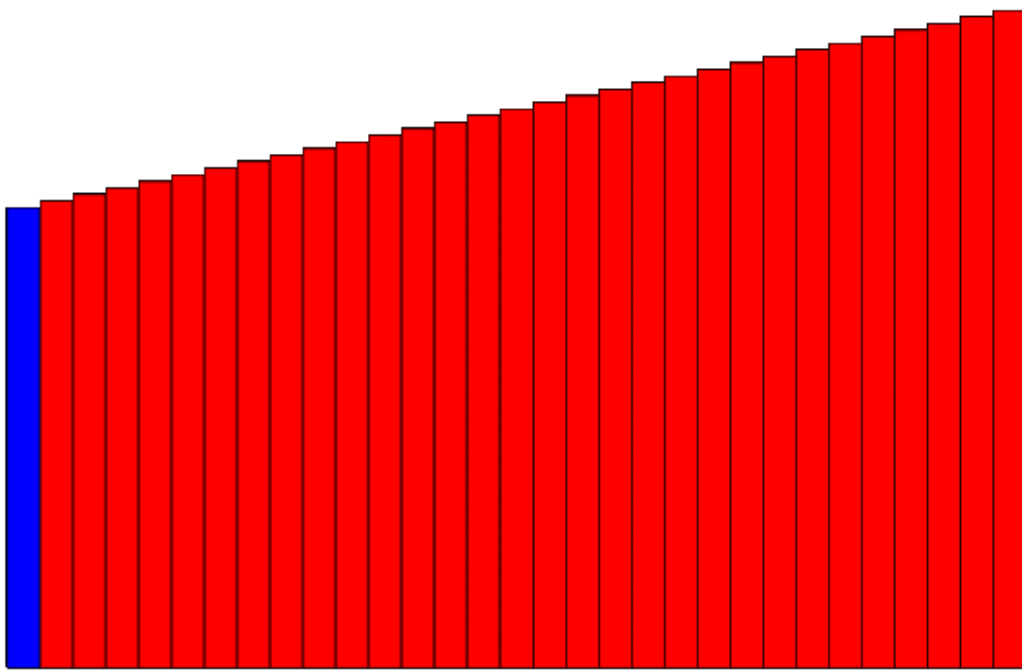

Constant Impedance vs. Constant Gradient

- In a travelling wave structure, the beam extracts energy during its passage
 - ⇒ the gradient will be lower at the end of the structure
- This can be avoided by reducing the iris radius along the structure (tapering)
 - the smaller irises produce more gradient per power flowing through them
- An additional difference exists for the long-range transverse wakefields
 - in a constant impedance structure one strong wakefield mode exists
 - in a tapered structure many small modes exist which reduces the effective wakefield

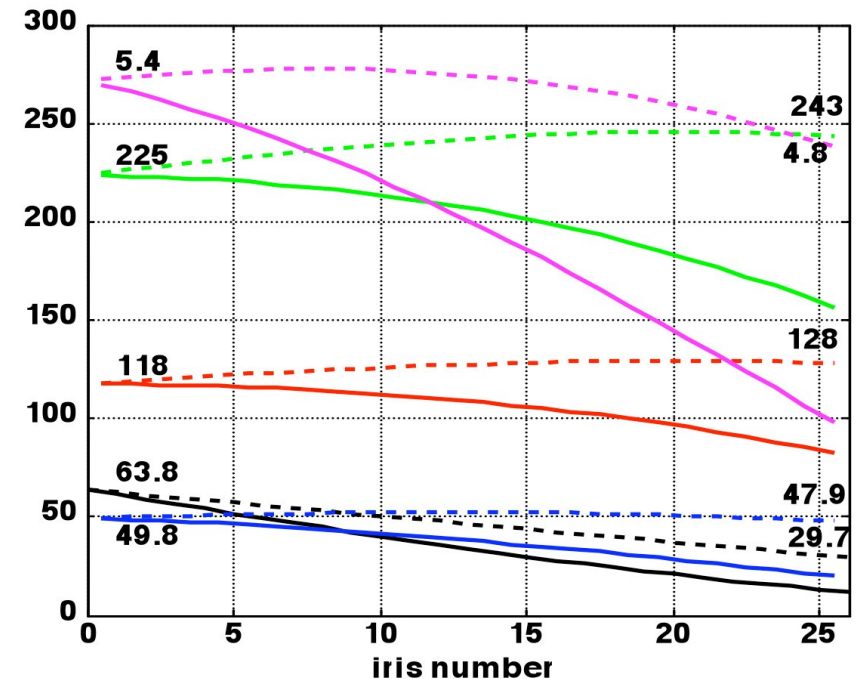

RF to Beam Power Efficiency Summary

parameter	CLIC	ILC (RDR)
R'/Q	$\approx 11 \text{ k}\Omega/\text{m}$	$1.036 \text{ k}\Omega/\text{m}$
Q	≈ 6000	$\approx 10^{10}$
R'	$\approx 66 \text{ M}\Omega/\text{m}$	$\approx 10^7 \text{ M}\Omega/\text{m}$

• ILC: $I \approx 5.8 \text{ mA}$

• CLIC: $I \approx 1.2 \text{ A}$

\Rightarrow

$$\frac{P'_{beam}}{P'_{wall}} \approx 1650$$

\Rightarrow

$$\frac{P'_{beam}}{P'_{wall}} \approx 0.8$$

- Efficiency is

$$\eta = \frac{\tau_{beam}}{\tau_{beam} + \tau_{fill}} \frac{P_{beam}}{P_{beam} + P_{loss} + P_{out}}$$

- Plugging in numbers for ILC

$$\eta \approx \frac{730 \mu\text{s}}{730 \mu\text{s} + 900 \mu\text{s}} \approx 0.45$$

- Plugging in (slightly older) numbers for CLIC

$$\eta = \frac{156 \text{ ns}}{156 \text{ ns} + 83 \text{ ns}} \cdot \frac{27 \text{ MW}}{27 \text{ MW} + 25 \text{ MW} + 12 \text{ MW}} \approx 0.65 \cdot 0.42 \approx 0.277$$

Remark: Drive Beam Accelerator

- High current at low gradient allows high efficiency

$$\frac{P'_{beam}}{P'_{wall}} = \frac{R'I}{G}$$

- Acceleration at low frequency is efficient

- Q is high $Q \propto 1/\sqrt{\omega}$

- klystrons are efficient

- In CLIC $\eta \approx 97.5\%$ expected

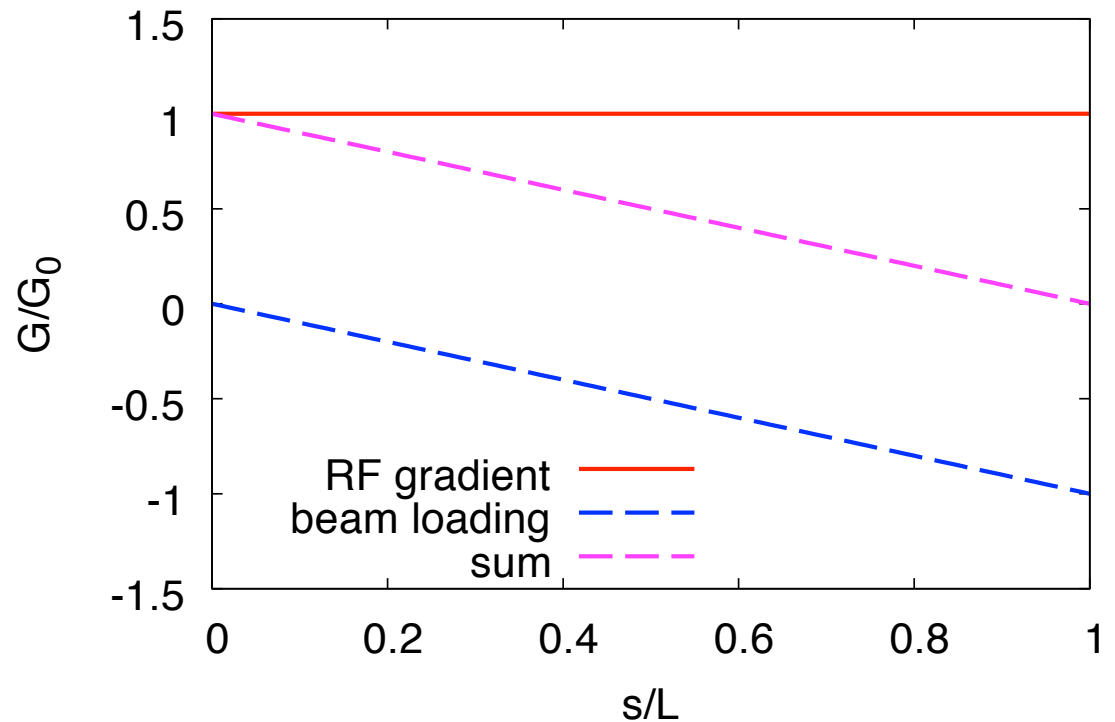

- Structure needs to be long enough not to have power leaking out

$$G = G_{RF} + G_{BL} \quad G = \frac{1}{2}G_{RF}$$
$$G_{BL} \propto LI$$

ILC Limiting Factors for Efficiency

Cavities have small losses

$$P_{loss} = const \frac{1}{Q_0} \times G^2$$

About 1W/m

But cooling costly at low temperatures

Remember Carnot:

$$P_{cryo} = \frac{1}{\eta} \frac{T_{room} - T_{source}}{T_{source}} \times P_{loss}$$

$$P_{cryo} \approx 700 \times P_{loss}$$

The typical heat load of 1 W/m
⇒ about 1 kW/m for cryogenics

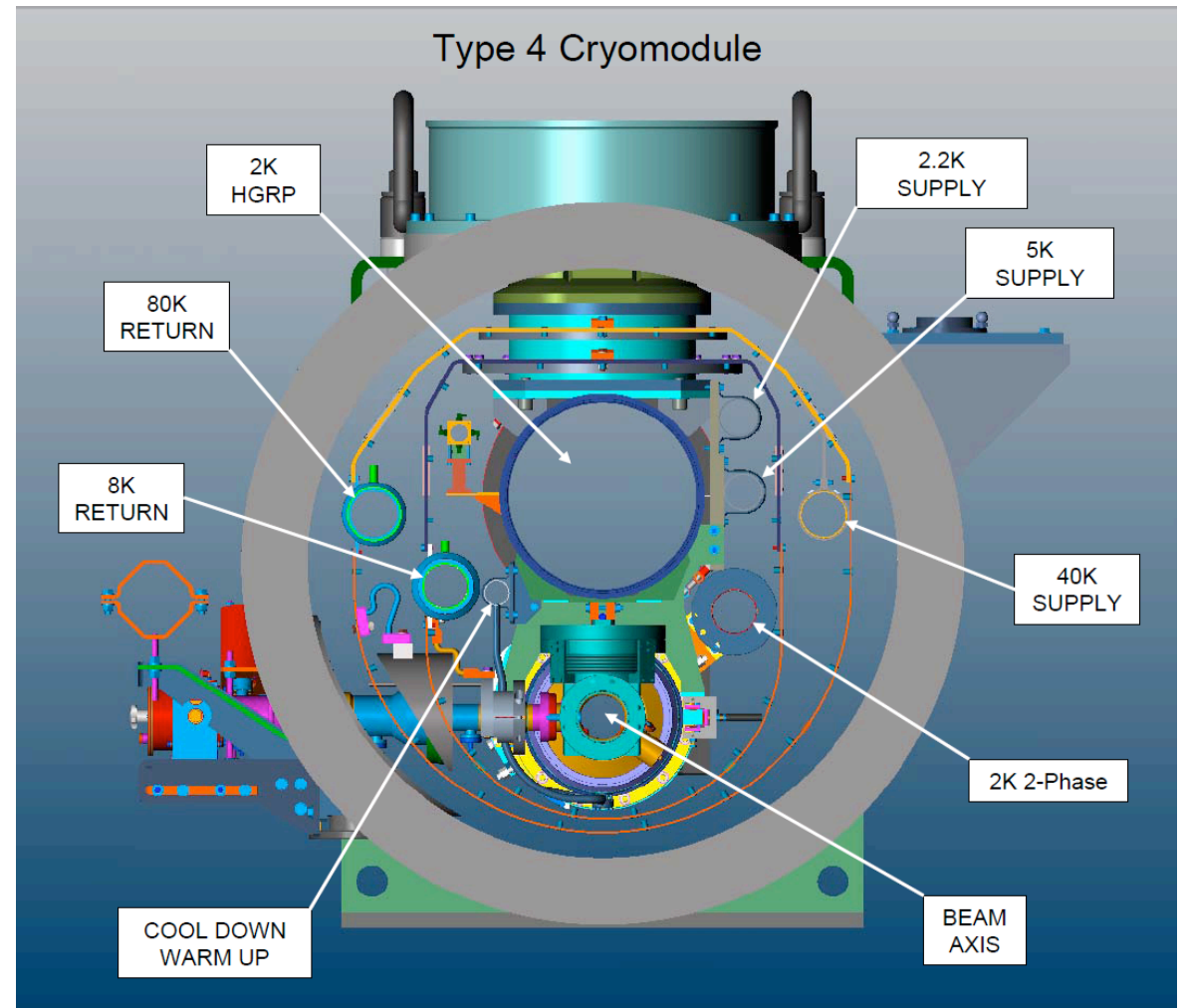

Average RF power: 1.6kW/m (3kW/m)
Power into beam about 0.7kW/m

Superconducting CW Operation

- Can easily calculate for ILC that operating CW leads to a total heat load of 1.5 MW
 - this requires 1 GW of power to cool

⇒ need the pulsed operation
- In an FEL need less final energy
 - can afford a lower gradient
 - which may also increase the Q

⇒ CW operation is interesting

 - no losses due to the filling time

CLIC Limiting Factors for the Efficiency

- A lower gradient G
 - leads to a longer main linac hence to higher cost
 - requires reducing the current
 - A higher shunt impedance R^t
 - leads usually to larger wakefields also in the transverse hence to a less stable beam
 - A higher beam current I
 - leads to a less stable beam
 - An optimisation can be performed of the whole machine
 - varying G and R^t and adjusting the current to the highest possible value
 - selecting the best combination taking into account luminosity and cost
 - This optimisation has indeed been performed for CLIC
- ⇒ let us see which is the highest current for a given structure and gradient

Beam Parameters: Longitudinal Wake and Bunch Charge Limits

Correlating bunch length and charge



Wakefields and Bunch Length

- Aim for shortest possible bunch to reduce transverse wakefield effects
- Energy spread into the beam delivery system should be limited to about 1% full width or 0.35% rms
- Multi-bunch beam loading compensated by RF
- Single bunch longitudinal wakefield needs to be compensated
⇒ accelerate off-crest

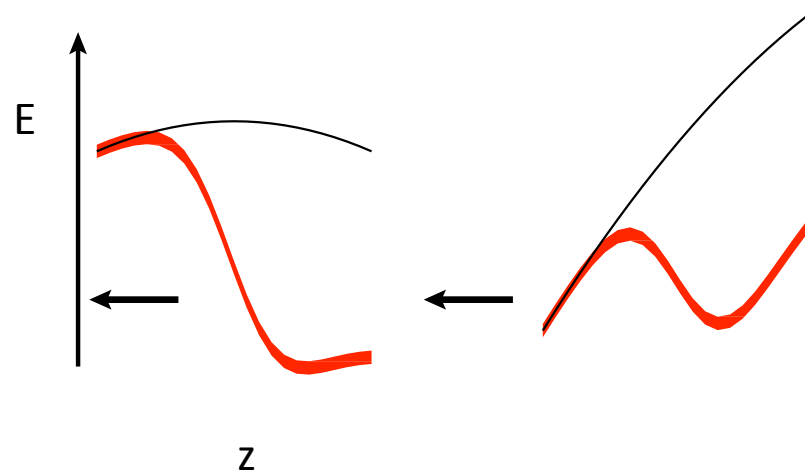

- Limit around average $\Delta\Phi \leq 12^\circ$
⇒ $\sigma_z = 44 \mu\text{m}$ for $N = 3.72 \times 10$

Specific Wakefields

- Longitudinal wakefields contain more than the fundamental mode
- We will use wakefields based on fits derived by Karl Bane

l length of the cell

a radius of the iris aperture

g length between irises

$$z_0 = 0.41a^{1.8}g^{1.6} \left(\frac{1}{l}\right)^{2.4}$$

$$W_L(z) = \frac{Z_0 c}{\pi a^2} \exp\left(-\sqrt{\frac{z}{z_0}}\right)$$

- Use CLIC structure parameters

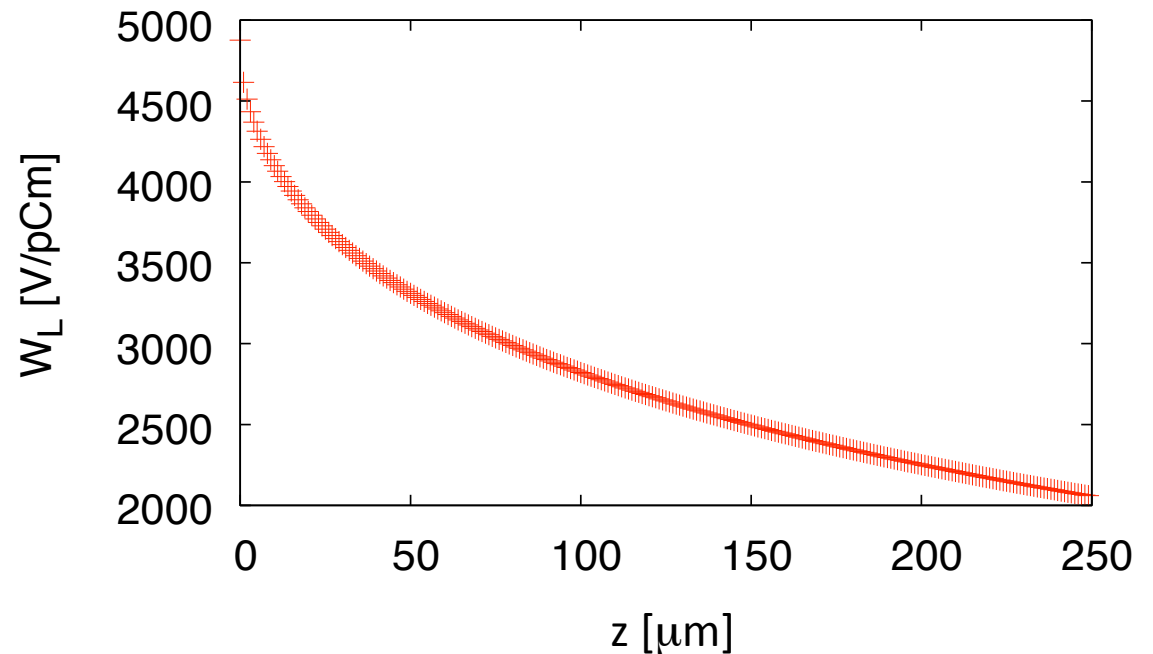

- Summation of an infinite number of cosine-like modes
 - calculation in time domain or approximations for high frequency modes

Energy Spread at End of Linac

- We use a constant RF phase along the linac
- Have to fold the longitudinal wakefield with bunch charge distribution

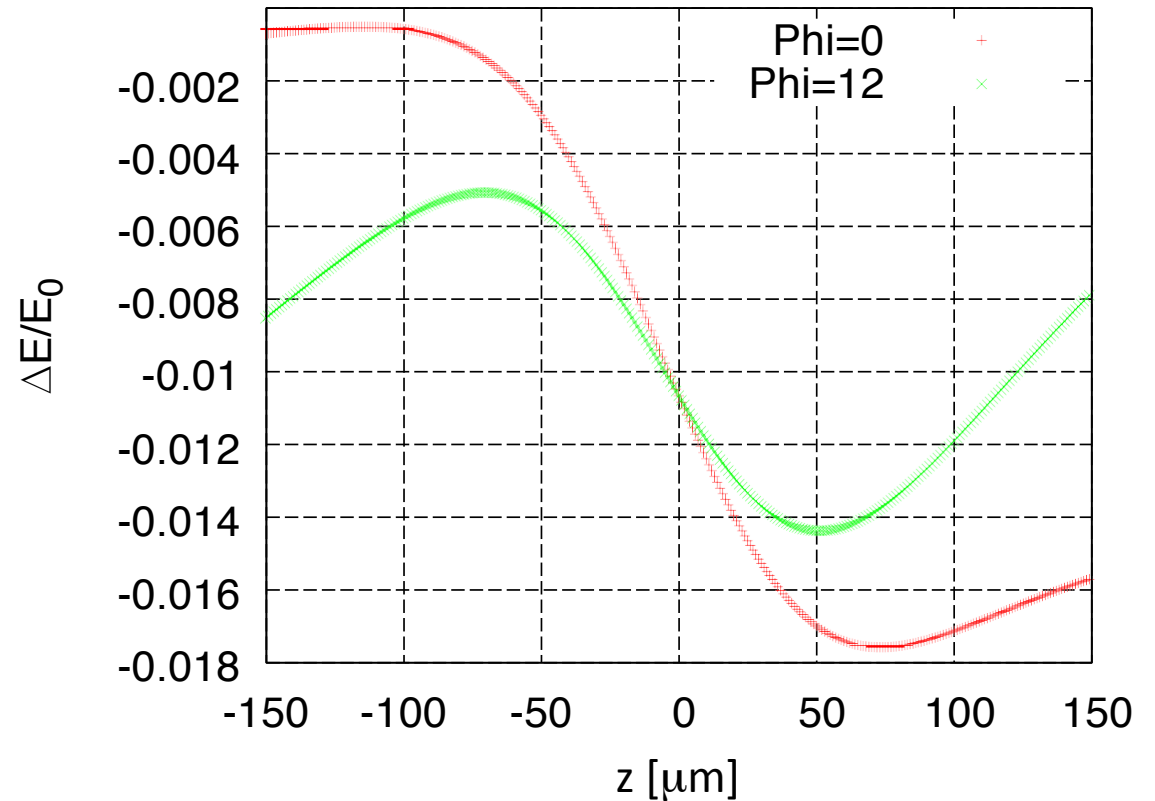

$$\delta G(z_0) = \int_{-\infty}^{z_0} \rho(z) W_L(z_0 - z) dz$$

Recipe for Choosing the Bunch Parameters

- Decide on the average RF phase
 - OK, we fix 12°
 - smaller values give less bunch charge, larger values give more sensitivity to phase jitter
- Decide on an acceptable energy spread at the end of the linac
 - OK, we choose 0.35%
 - mainly from BDS and physics requirements
- Determine $\sigma_z(N)$
 - choose a bunch charge
 - vary the bunch length until the final energy spread is acceptable
 - choose next charge
- Determine which bunch charge (and corresponding bunch length) can be transported stably

Simplified Treatment

Assume

- $W_z(s) = W_z = \text{const}$
- uniform bunch with length $L \ll \lambda$
- and use linear approximation

Field seen by first particle

$$G_H = G \cos\left(\phi - \frac{L}{2} \frac{2\pi}{\lambda}\right) \approx G \left(\cos(\phi) - \frac{L}{2} \frac{2\pi}{\lambda} \sin(\phi)\right)$$

Field seen by last particle

$$G_T = G \cos\left(\phi + \frac{L}{2} \frac{2\pi}{\lambda}\right) \approx G \left(\cos(\phi) + \frac{L}{2} \frac{2\pi}{\lambda} \sin(\phi)\right) - NeW_z$$

We require (this automatically solves the equation for all other particles)

$$G_H = G_T$$

which leads to

$$L = \frac{NeW_z}{G} \frac{\lambda}{2\pi \sin(\phi)}$$

Dependence of Energy Spread on Bunch Length

- For a given charge and phase the bunch length is varied

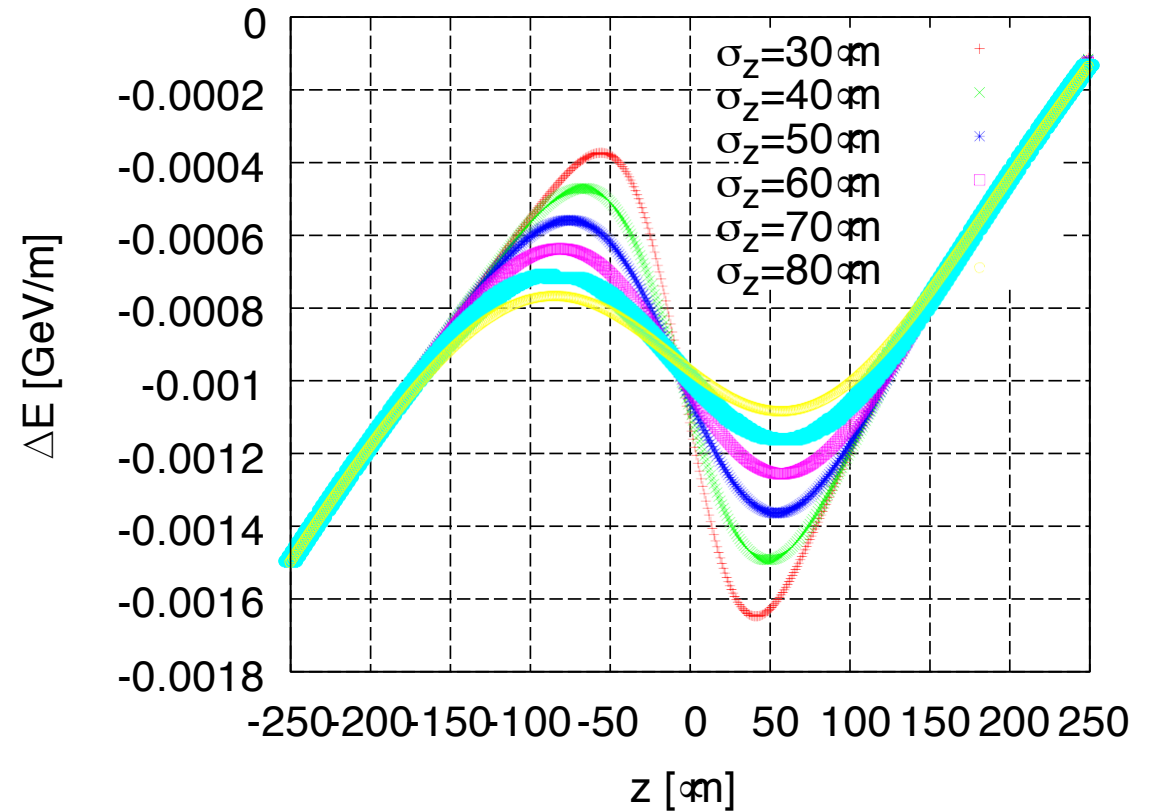

Note: Energy Spread Along Linac

- Three regions
 - generate
 - maintain
 - compress
- Configurations are named according to RF phase in section 2
- Trade-off in fixed lattice
 - large energy spread is more stable
 - small energy spread is better for alignment

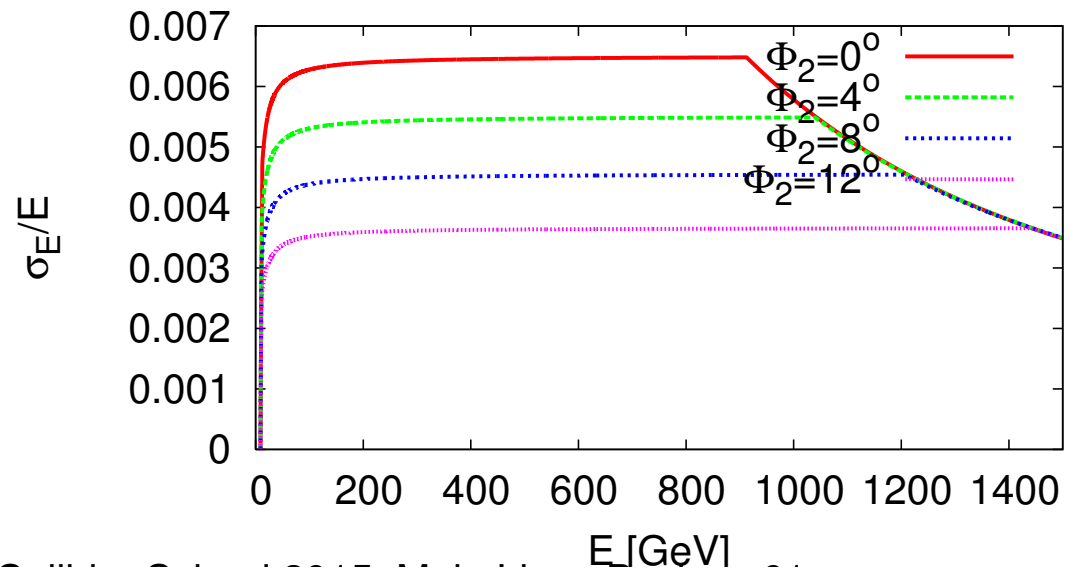
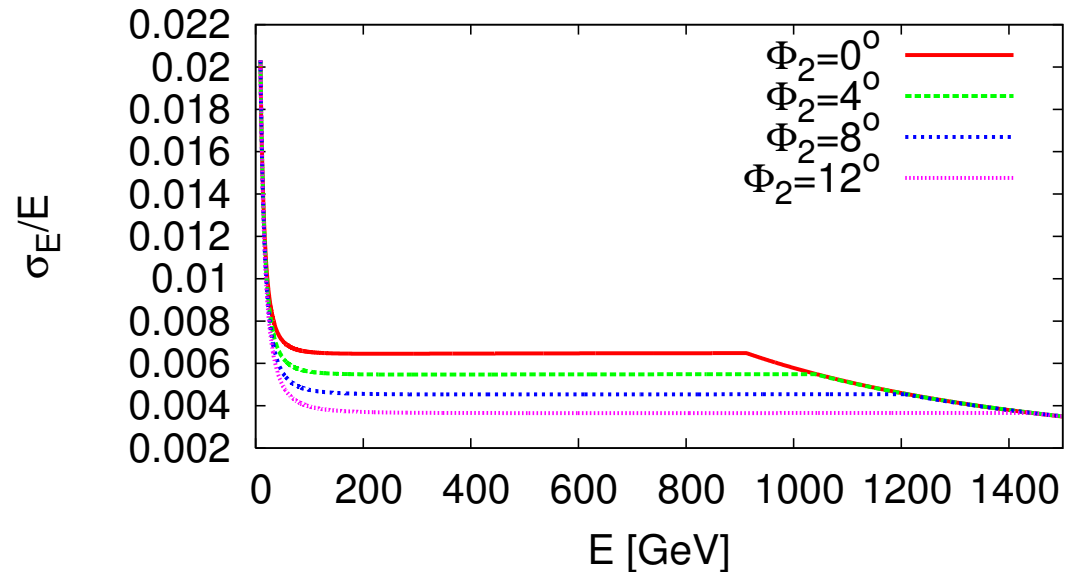

Beam Parameters: Beam Transport and Emittance

Know $\sigma_z(N)$ but current limit will depend on wakefields and lattice design, important problem



Emittance

- The beam particles do not have identical coordinates
 - they occupy some phase space
- According to Liouville theorem (from the Liouville equation)

$$\frac{d\rho}{dt} = \frac{\partial \rho}{\partial t} + \sum_{i=1}^N \left[\frac{\partial \rho}{\partial q_i} \dot{q}_i + \frac{\partial \rho}{\partial p_i} \dot{p}_i \right] = 0$$

the density in phase space around a trajectory remains constant in an unperturbed system

- For some reason particles are conventionally not described by (x, y, z, p_x, p_y, p_z) but by (x, y, z, x', y', E)
 - ⇒ in this representation the “phase space” changes
- We use the emittance to describe the phase space volume
 - geometric emittance is the actual size in $x x'$ and changes with acceleration
 - the normalised emittance is size in $x x'$ for $\gamma = 1$ and is constant

Why is the Emittance Important?

The luminosity can be written as

$$\mathcal{L} \propto H_D \frac{N}{\sigma_x} N n_b f_r \frac{1}{\sigma_y}$$

And the beam size is given by
 β at the IP, a lattice property
 ϵ at the IP, a beam property

$$\sigma_y = \sqrt{\beta_y \epsilon_y / \gamma}$$

Main Linac Emittance Growth

- The vertical emittance is most important since it is much smaller than the horizontal one (10 nm vs. 600 nm, 24 nm vs. 8400 nm)
- For a perfect implementation of the machine the main linac emittance growth would be negligible
- Two main sources of emittance growth exist
 - static imperfections
 - dynamic imperfections
- The emittance growth budget is 5 nm for static imperfections
 - i.e. 90% of the machines must be better
- For dynamic imperfections the budget is 5 nm
 - but short term fluctuation must be smaller to avoid problems with luminosity tuning

Low Emittance Transport Challenges

- Beam stability
 - incoming beam can jitter (have small offsets) and become unstable
 - lattice design, choice of beam parameters
- Static imperfections
 - errors of reference line, elements to reference line, elements. . .
 - excellent pre-alignment, lattice design, beam-based alignment, beam-based tuning
- Dynamic imperfections
 - element jitter, RF jitter, ground motion, beam jitter, electronic noise,. . .
 - lattice design, BNS damping, component stabilisation, feedback, re-tuning, re-alignment
- Combination of dynamic and static imperfections can be severe
- Lattice design needs to balance dynamic and static effects

Guiding the Beams: Quadrupoles

- The focusing is provided by quadrupoles
- They focus in one plane but defocus in the other planes
 - octapoles would focus in x and y but defocus in the planes at 45°
 - also their magnetic field is not linear

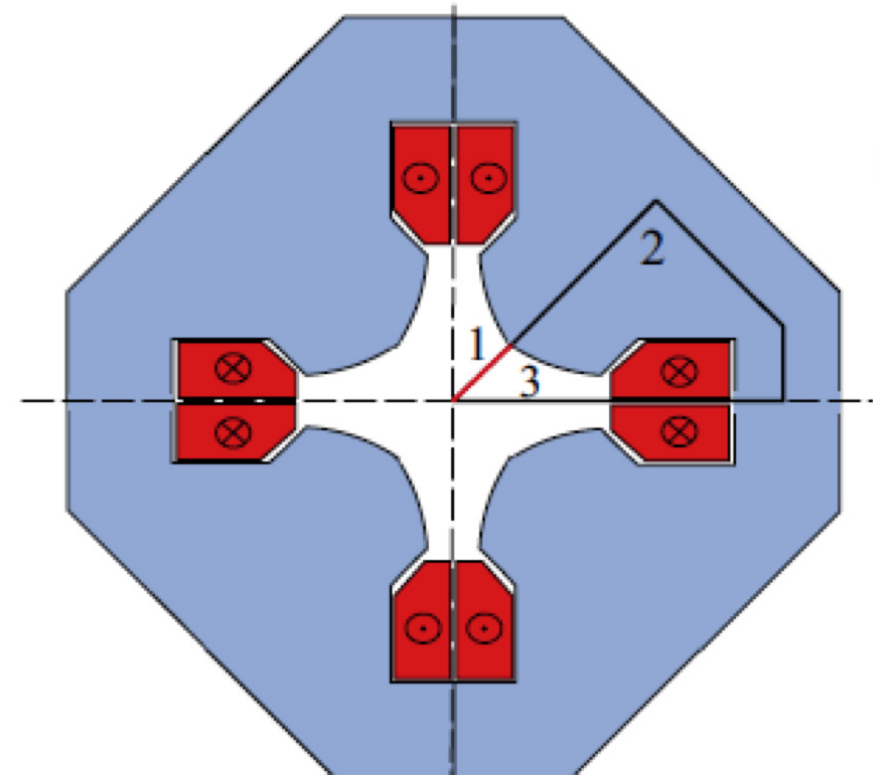
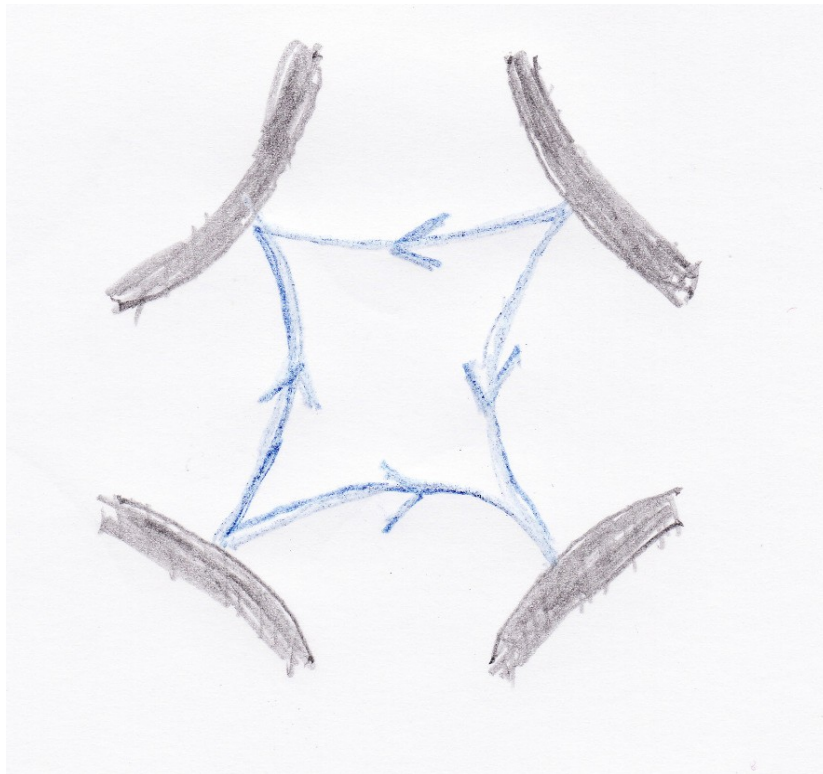
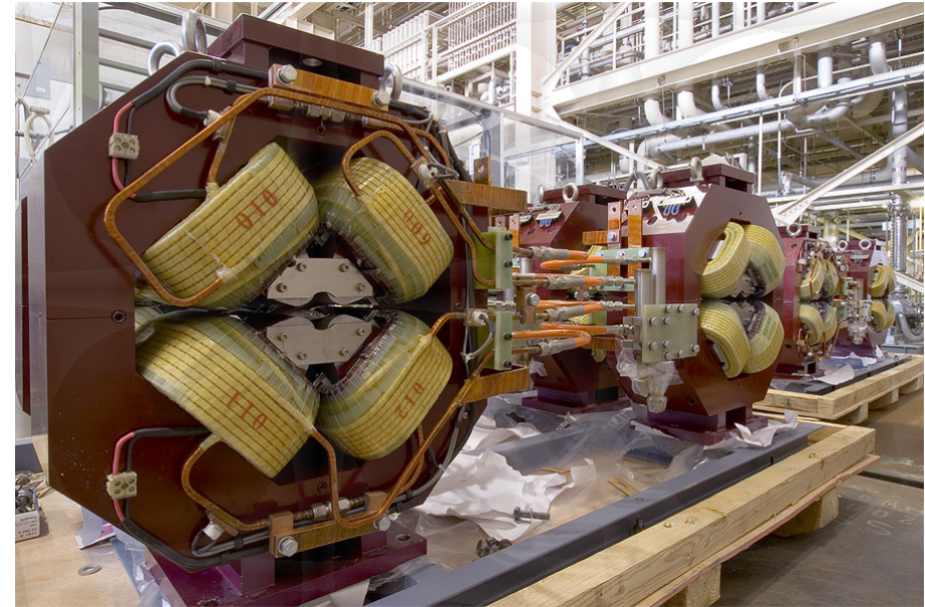

FODO Lattice

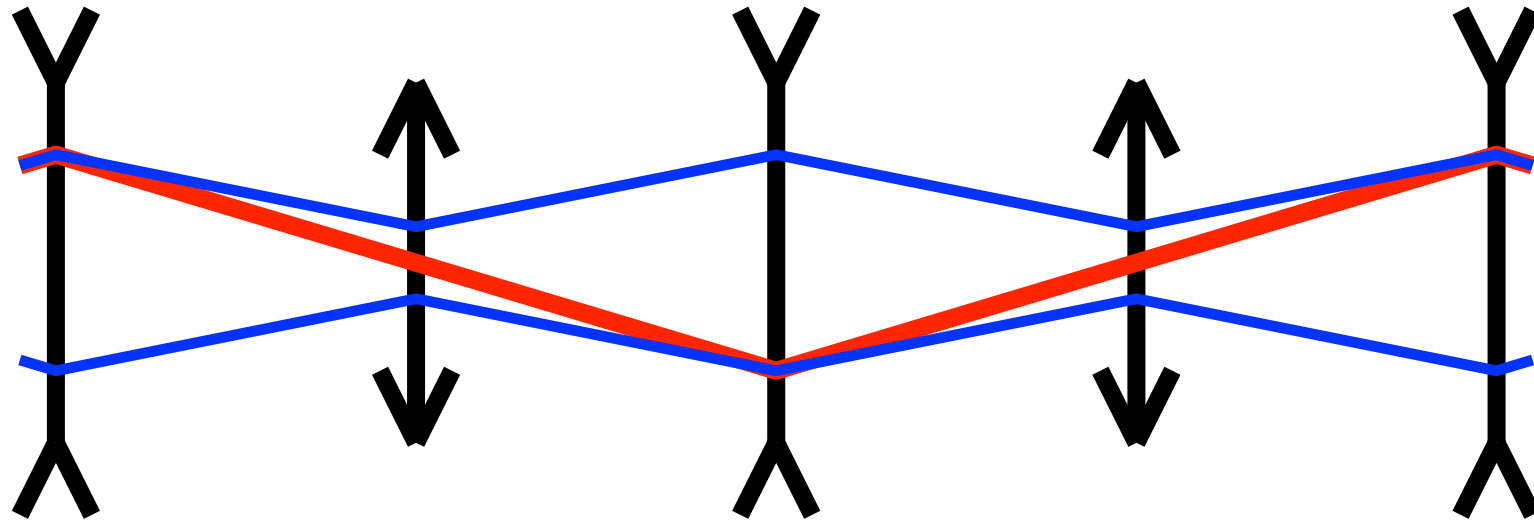

Focusing is achieved by alternating focusing and defocusing quadrupoles

ILC Lattice

- In the ILC constant quadrupole spacing is chosen
- The phase advance per cell is constant
- The phase advance is different in the two planes
 - reduces some coupling effects between the two planes

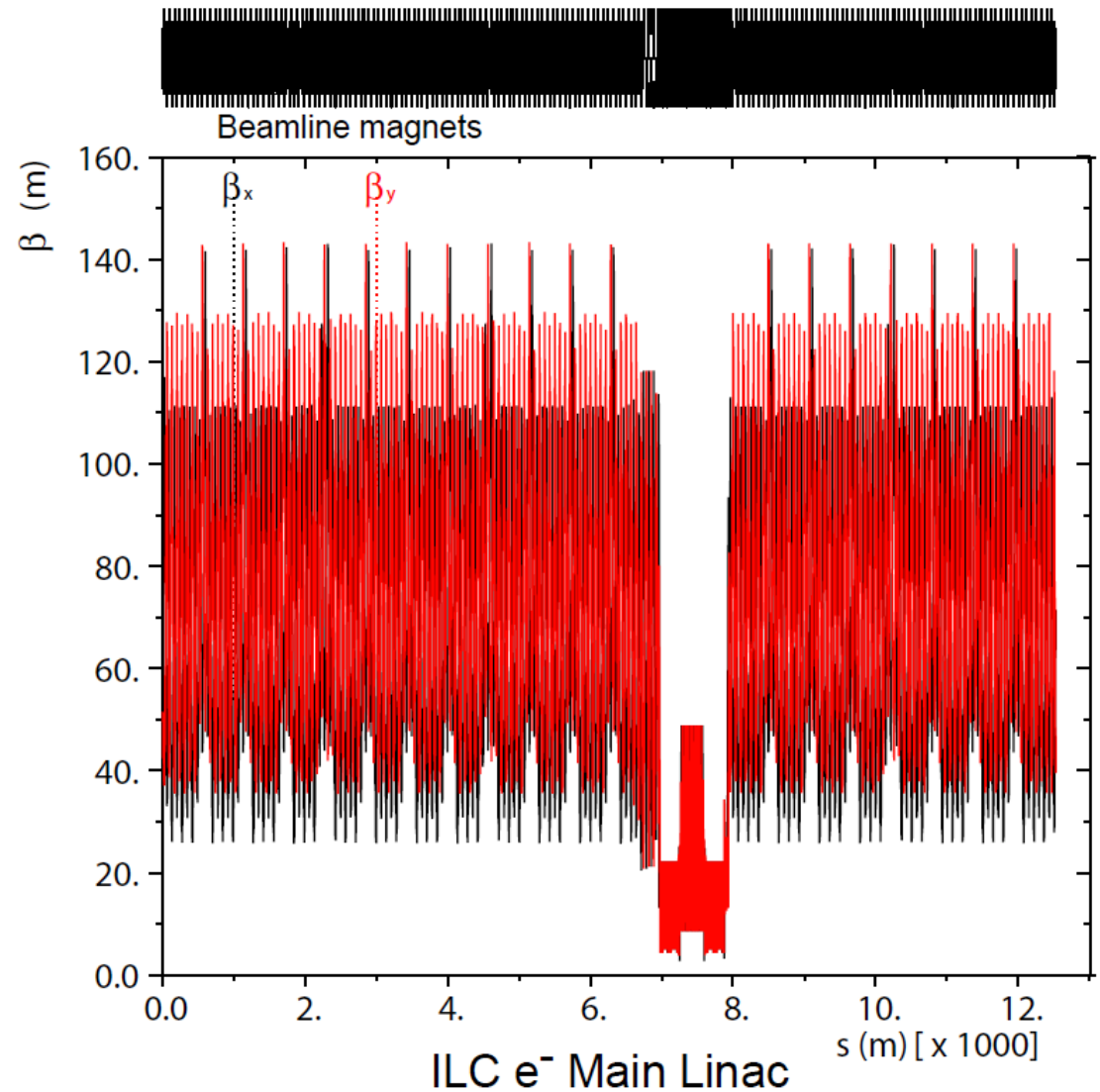
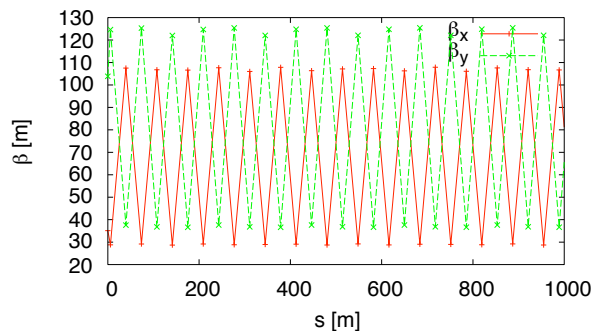

CLIC Lattice Design

- Use strong focusing (small β) to stabilise beam
 - 10% of linac are quadrupoles
- Used $\beta \propto E^{1/2}$, $\Delta\Phi = \text{const}$
 - Quadrupole spacing and length scale as $E^{1/2}$
- ⇒ roughly constant fill factor
 - phase advance is chosen to balance between wakefield and ground motion effects
- Total length 20867.6m
 - fill factor 78.6%

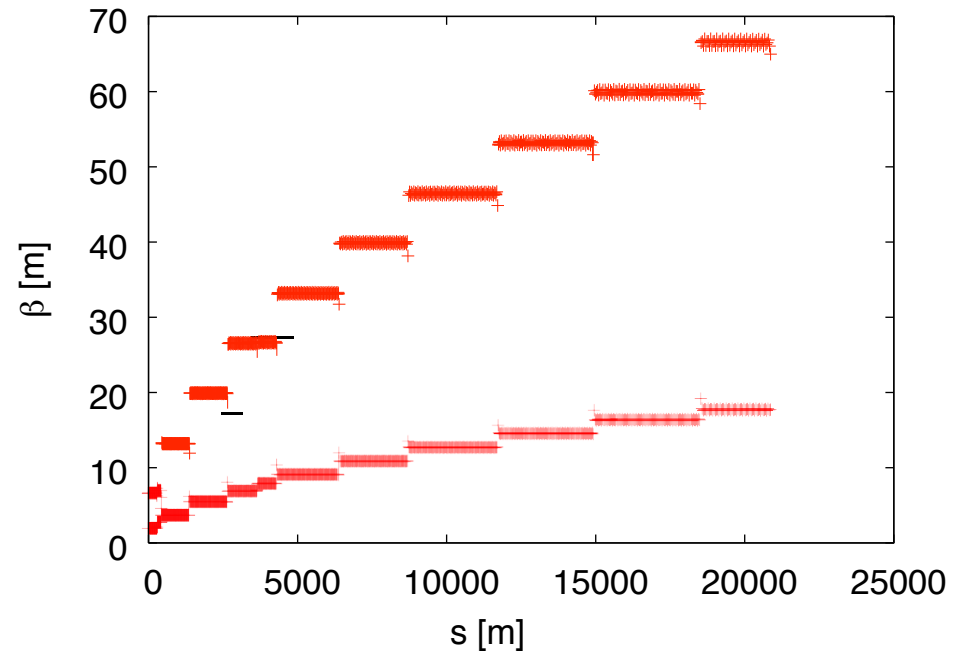

- 12 different sectors used
- Matching between sectors using 7 quadrupoles to allow for some energy bandwidth

Note: fill factor = active length/total length

Hill's Equation and Beta-Functions

- In many interesting cases the particle motion can be described by Hill's equation

$$x''(s) + K(s)x(s) = 0$$

i.e. a harmonic oscillator with varying spring constant

The solutions for this equation can be formulated as

$$x(s) = \sqrt{\epsilon\beta(s)} \cos(\phi(s) + \phi_0)$$
$$x'(s) = \sqrt{\frac{\epsilon}{\beta(s)}} \left[\frac{\beta'}{2} \cos(\phi(s) + \phi_0) - \sin(\phi(s) + \phi_0) \right]$$

where

$$\phi(s) = \int_0^s \frac{1}{\beta(s')} ds'$$

and β has to fulfill

$$\frac{\beta''\beta}{2} - \frac{\beta'^2}{4} + K\beta^2 = 1$$

- The solution can be easily verified
- It depends partially on the particle (ϵ, ϕ_0) and partially on the lattice (β)

Phase Space Representation

$$x(s) = \sqrt{\epsilon\beta(s)} \cos(\phi(s) + \phi_0)$$

$$x'(s) = \sqrt{\frac{\epsilon}{\beta(s)}} \left[\frac{\beta'(s)}{2} \cos(\phi(s) + \phi_0) - \sin(\phi(s) + \phi_0) \right]$$

As homework you will show that $K(s) = \text{const}$ leads to $\beta = \text{const}$

$$x(s) = \sqrt{\epsilon\beta} \cos\left(\frac{s}{\beta} + \phi_0\right)$$

$$x'(s) = -\sqrt{\frac{\epsilon}{\beta}} \sin\left(\frac{s}{\beta} + \phi_0\right)$$

⇒ You can understand most things assuming a harmonic oscillator and some average beta-function

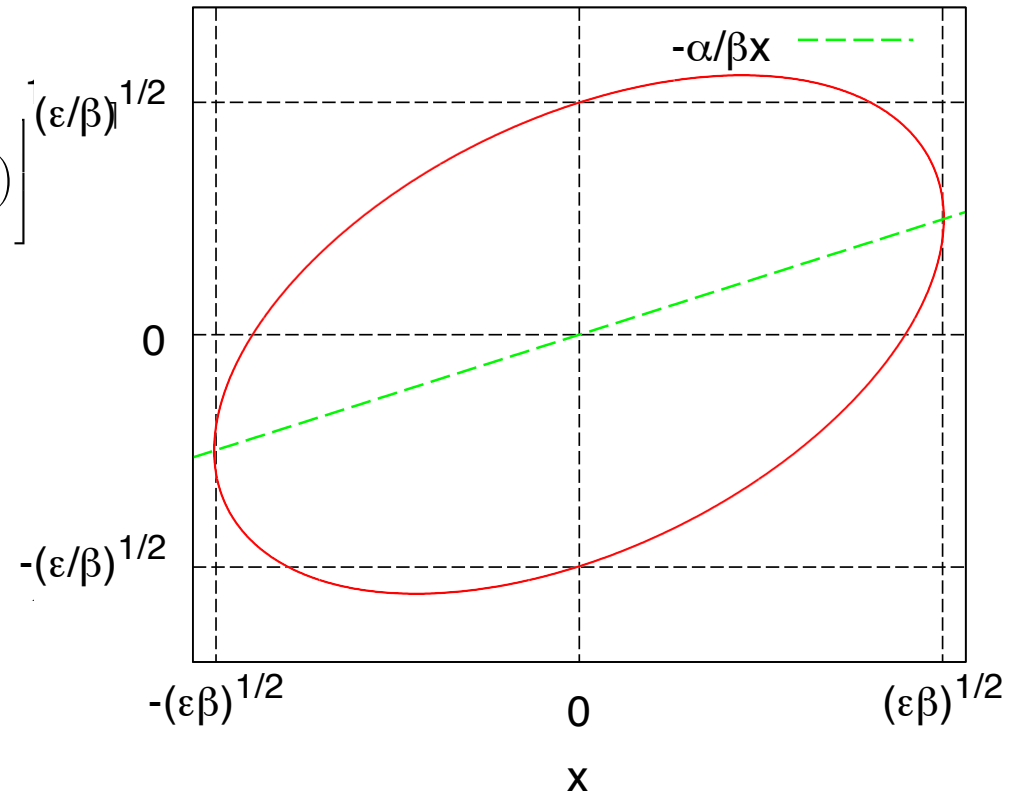

Beam Parameters: Transverse Wakefields and Beam Break-up

Limit on the bunch charge



Example of Single Bunch Transverse Wakefield (CLIC)

Fit obtained by K. Bane

For short distances the wake- field rises linear

Summation of an infinite number of sine-like modes with different frequencies

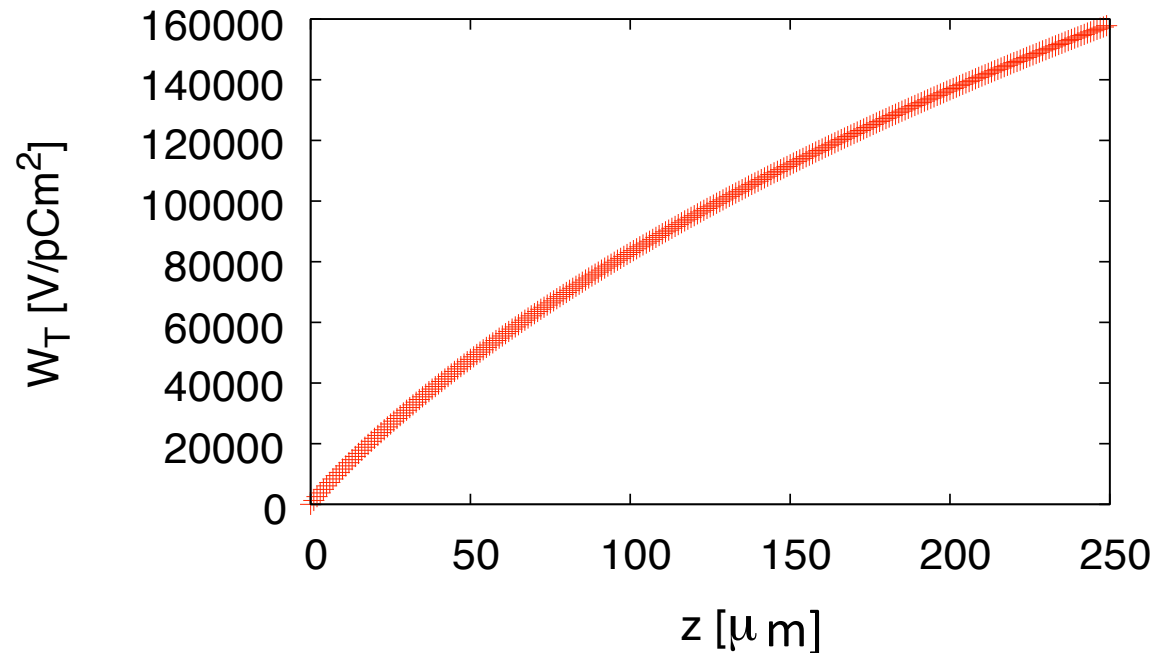

$$W_{\perp}(z) = 4 \frac{Z_0 c z_0}{\pi a^4} \left[1 - \left(1 + \sqrt{\frac{z}{z_0}} \right) \exp \left(-\sqrt{\frac{z}{z_0}} \right) \right]$$

$$z_0 = 0.169 a^{1.79} g^{0.38} \left(\frac{1}{l} \right)^{1.17}$$

$$W_{\perp}(z \ll z_0) \approx 2 \frac{Z_0 c}{\pi a^4} z$$

Beam Stability

Transverse stability of beam
with initial offset σ_y

- No energy spread
- Emittance with respect to beam axis shown

⇒ Acceptable for ILC

⇒ Not acceptable for CLIC

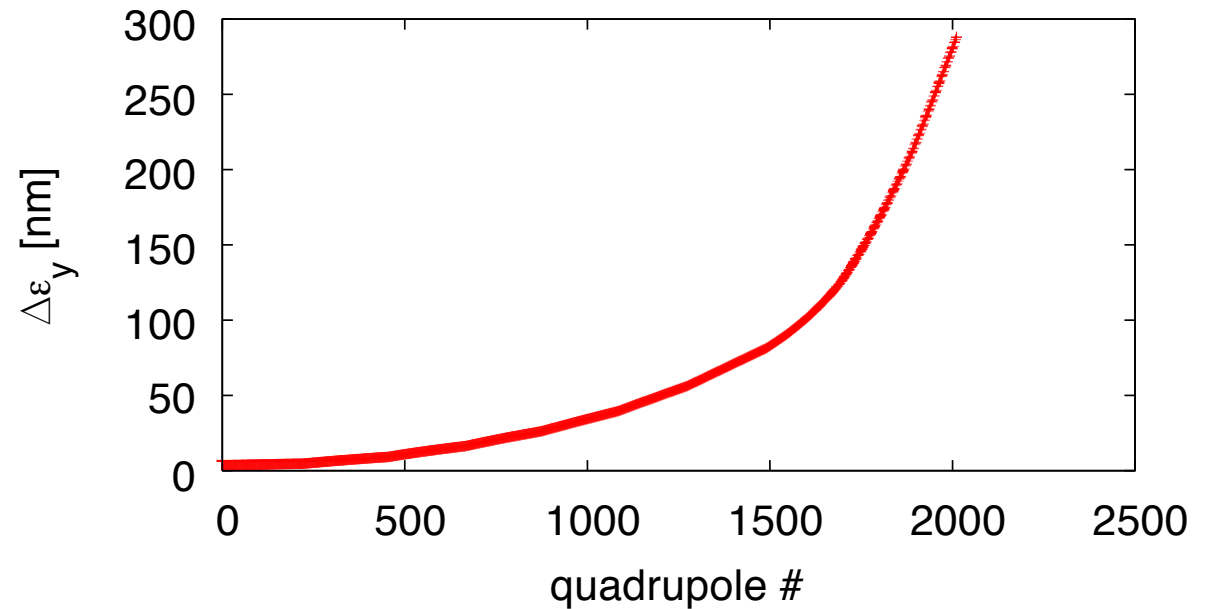
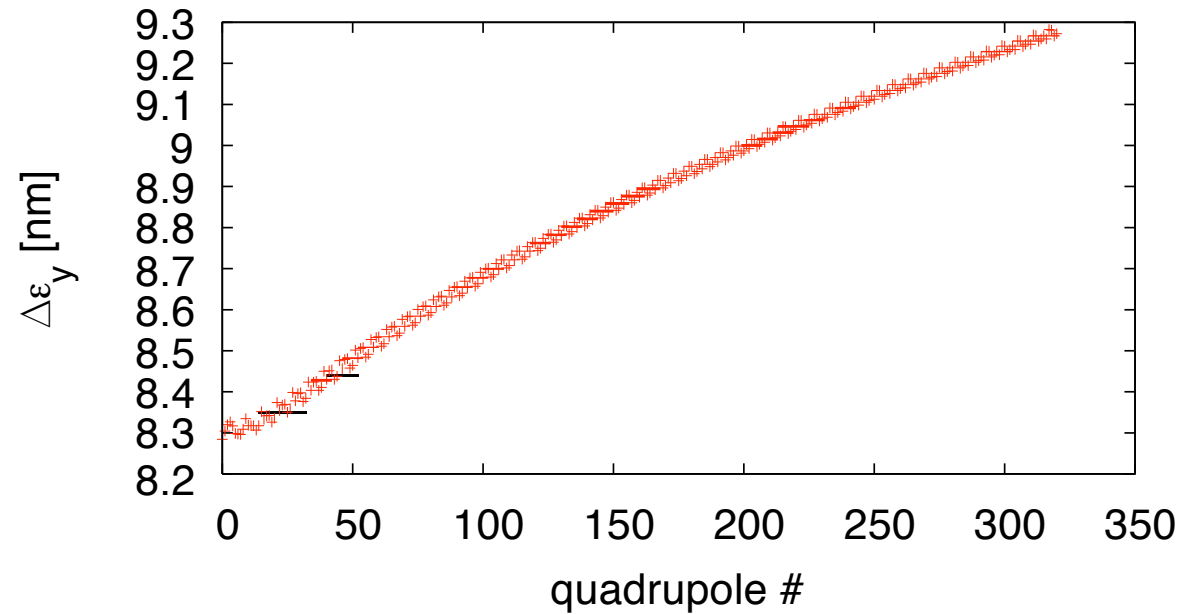

Achieving Beam Stability

- Transverse wakes act as defocusing force on tail
⇒ beam jitter is exponentially amplified

- BNS damping (Balakin, Novokhatsky and Smirnov) prevents this growth
- manipulate RF phases to have energy spread
 - take spread out at end

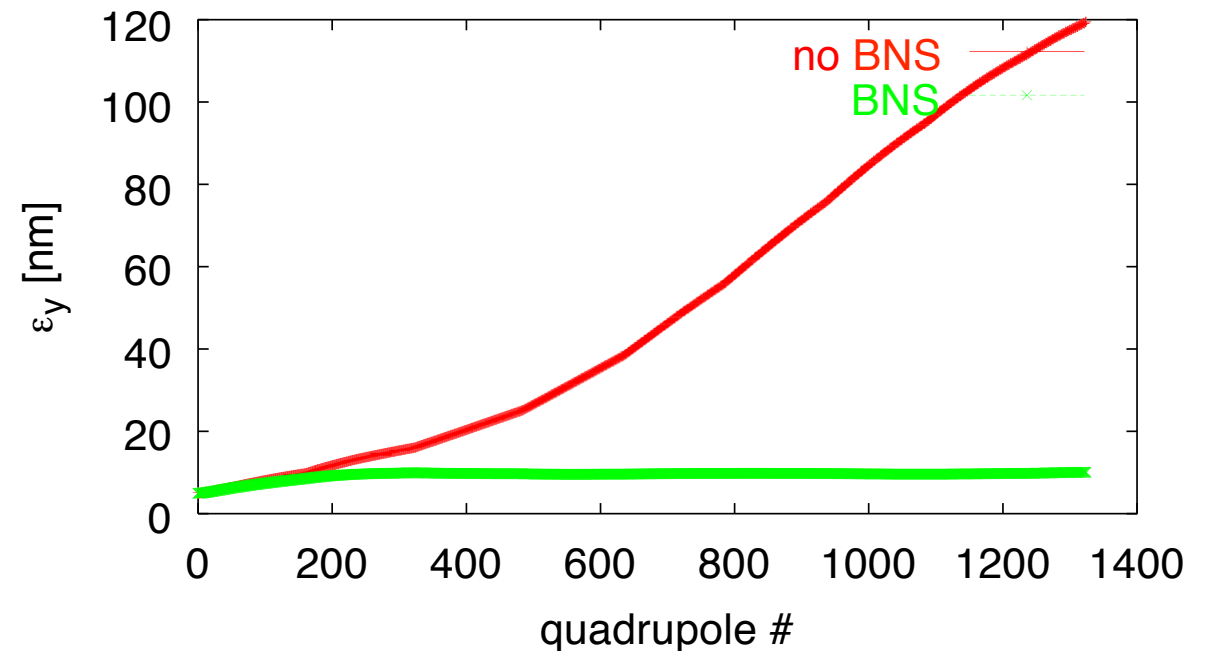
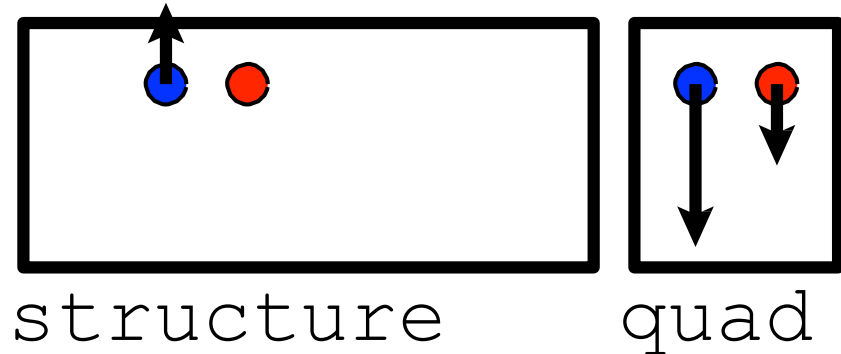

Two-Particle Wakefield Model

Assume bunch can be represented by two particles and constant $K(s) = 1/\beta^2$

- second particle is kicked by transverse wakefield

- initial oscillation

$$x_1'' + \frac{1}{\beta^2}x_1 = 0 \quad x_1(0) = x_0 \quad x_1'(0) = 0$$

$$\Rightarrow x_1 = x_0 \cos\left(\frac{s}{\beta}\right)$$

For the second particle

$$x_2'' + \frac{1}{\beta^2}x_2 = \frac{Ne^2W_{\perp}}{P_Lc}x_0 \cos\left(\frac{s}{\beta}\right) \quad x_2(0) = x_0 \quad x_2'(0) = 0$$

Solution is simple with an ansatz (and using $P_Lc = E$)

$$x_2 = x_0 \cos\left(\frac{s}{\beta}\right) + \left(\frac{x_0 Ne^2W_{\perp}\beta}{2E}s\right) \sin\left(\frac{s}{\beta}\right)$$

\Rightarrow Amplitude of second particle oscillation is growing linearly with s

Driving Parameters

$$x_2 = x_0 \cos\left(\frac{s}{\beta}\right) + \left(\frac{x_0 N e^2 W_{\perp} \beta}{2E} s\right) \sin\left(\frac{s}{\beta}\right)$$

- Factors for the amplitude growth of the second particle
 - β : small beta-function (strong focusing) helps
 - $1/E$: high energy helps
 - W_{\perp} : small wakefield helps
 - N : small bunch charge helps
 - s : shorter linac helps (i.e. higher gradient)

- The integral $\int \beta(s)/E(s) ds$ is very important for the linac

BNS Damping

For simplicity assume initial offset but no angle

First particle performs a harmonic oscillation

$$x_1(s) = x_0 \cos\left(\frac{s}{\beta_1}\right)$$

We want the second particle to perform the **same** oscillation, i.e.

$$x_2(s) = x_0 \cos\left(\frac{s}{\beta_1}\right)$$

Change **unperturbed** oscillation frequency of second particle (e.g. change energy)

$$x_2(s) = x_0 \cos\left(\frac{s}{\beta_2}\right)$$

Including the effect of the first particle yields

$$x_2'' + \frac{1}{\beta_2^2} x_2 = \frac{Ne^2 W_{\perp}}{E} x_0 \cos\left(\frac{s}{\beta_1}\right) = \frac{Ne^2 W_{\perp}}{E} x_1(s)$$

BNS Damping

$$x_2'' + \frac{1}{\beta_2^2} x_2 = \frac{Ne^2 W_{\perp}}{E} x_0 \cos\left(\frac{s}{\beta_1}\right) = \frac{Ne^2 W_{\perp}}{E} x_1(s)$$

Plugging in our wanted solution for $x_2(s)$

$$x_2(s) = x_0 \cos\left(\frac{s}{\beta_1}\right)$$

we find

$$-\frac{1}{\beta_1^2} x_0 \cos\left(\frac{s}{\beta_1}\right) + \frac{1}{\beta_2^2} x_0 \cos\left(\frac{s}{\beta_1}\right) = \frac{Ne^2 W_{\perp}}{E} x_0 \cos\left(\frac{s}{\beta_1}\right)$$

which is fulfilled for

$$\frac{1}{\beta_2^2} = \frac{1}{\beta_1^2} + \frac{Ne^2 W_{\perp}}{E}$$

which requires $E_2 < E_1$

⇒ No more wakefield effect

Energy Spread and Beam Stability

- Trade-off in fixed lattice

- large energy spread is more stable
- small energy spread is better for alignment

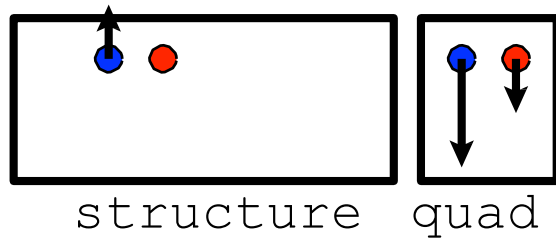

⇒ Beam with $N = 3.7 \times 10^9$
will be stable

⇒ Beam with larger charge will not
be stable (sorry, without plot)

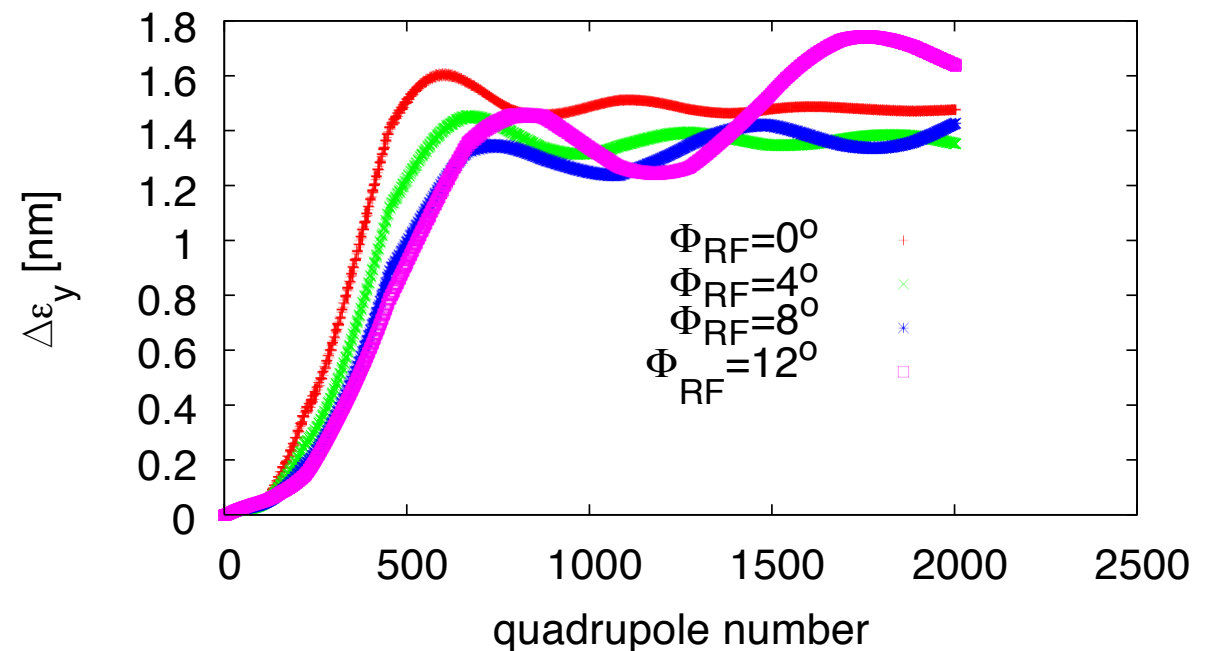
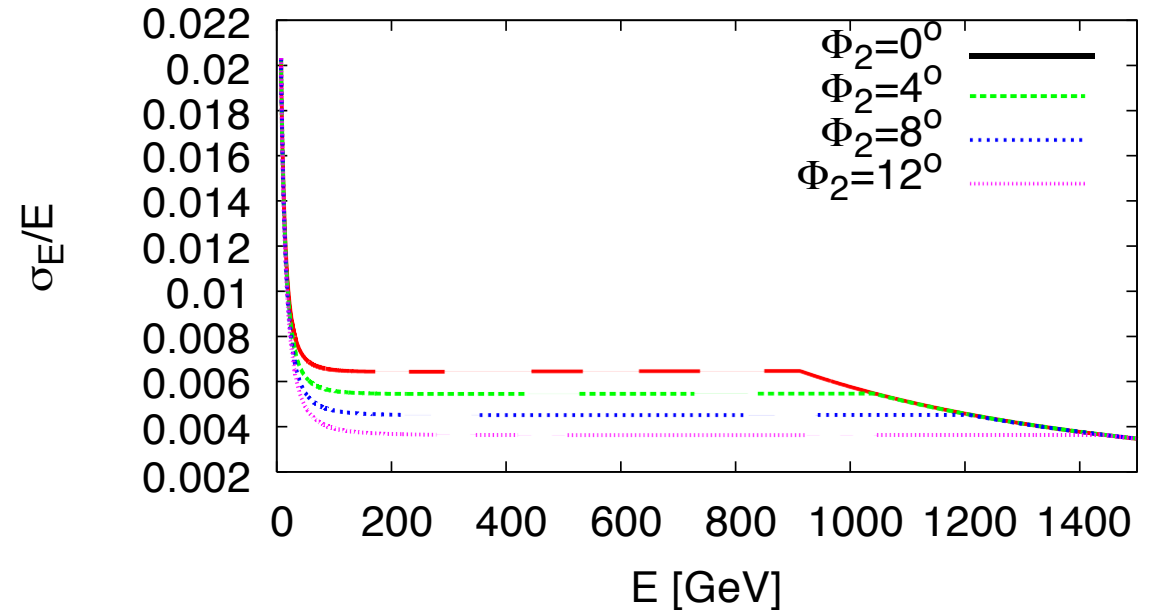

Beam Parameters: Multi-bunch Effects

Final component of the beam current



Multi-Bunch Wakefields

- Long-range transverse wakefield determines how close one can put the bunches in the linac
- Longrange transverse wakefields are sine-like
- They can be reduced by
 - Damping
 - Detuning

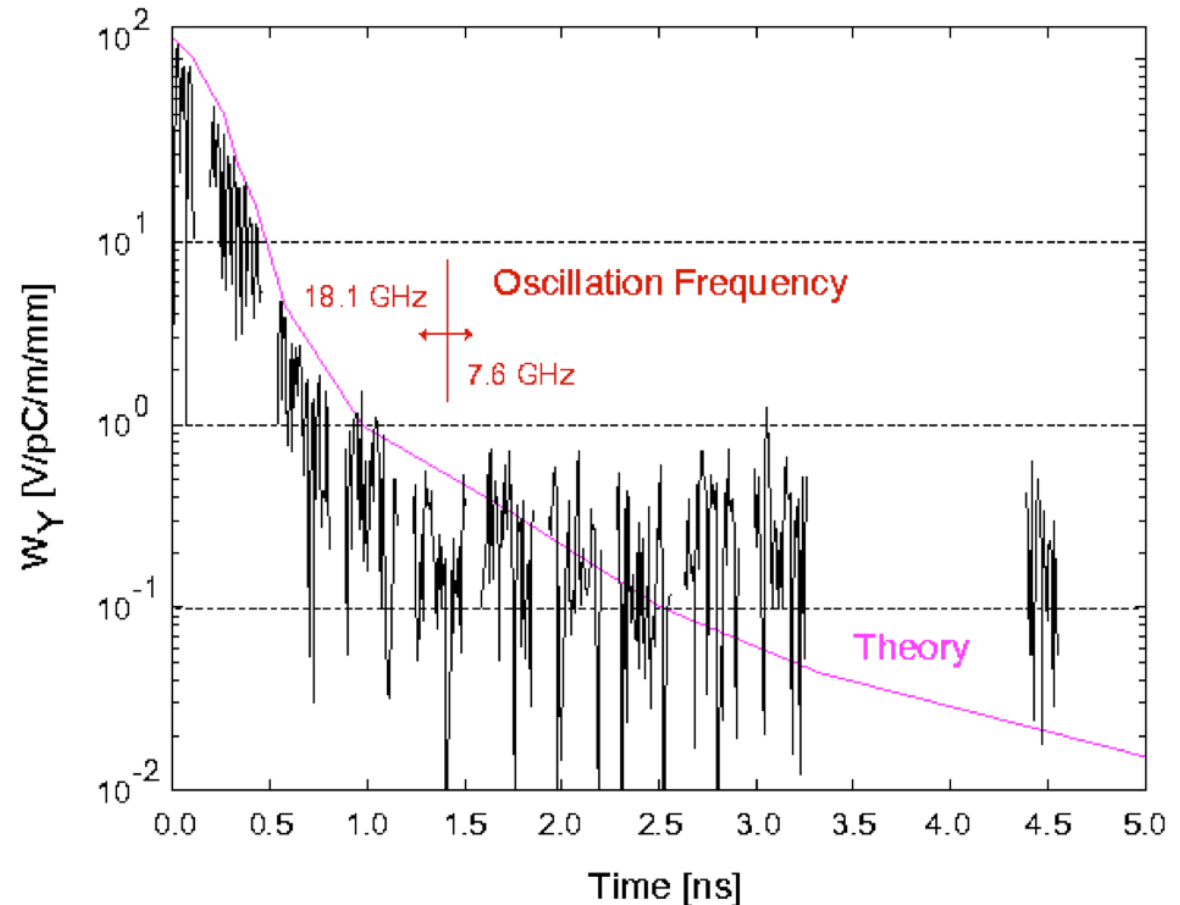

$$W_{\perp}(z) = \sum_i^{\infty} 2k_i \sin\left(2\pi \frac{z}{\lambda_i}\right) \exp\left(-\frac{\pi z}{\lambda_i Q_i}\right)$$

Damping

- Damping can be achieved by extracting the power of transverse modes from the structure
- In CLIC each cell has waveguides for this purpose
 - the fundamental mode cannot escape
- ILC has antennas at the end
 - weaker damping but bunch distance is larger

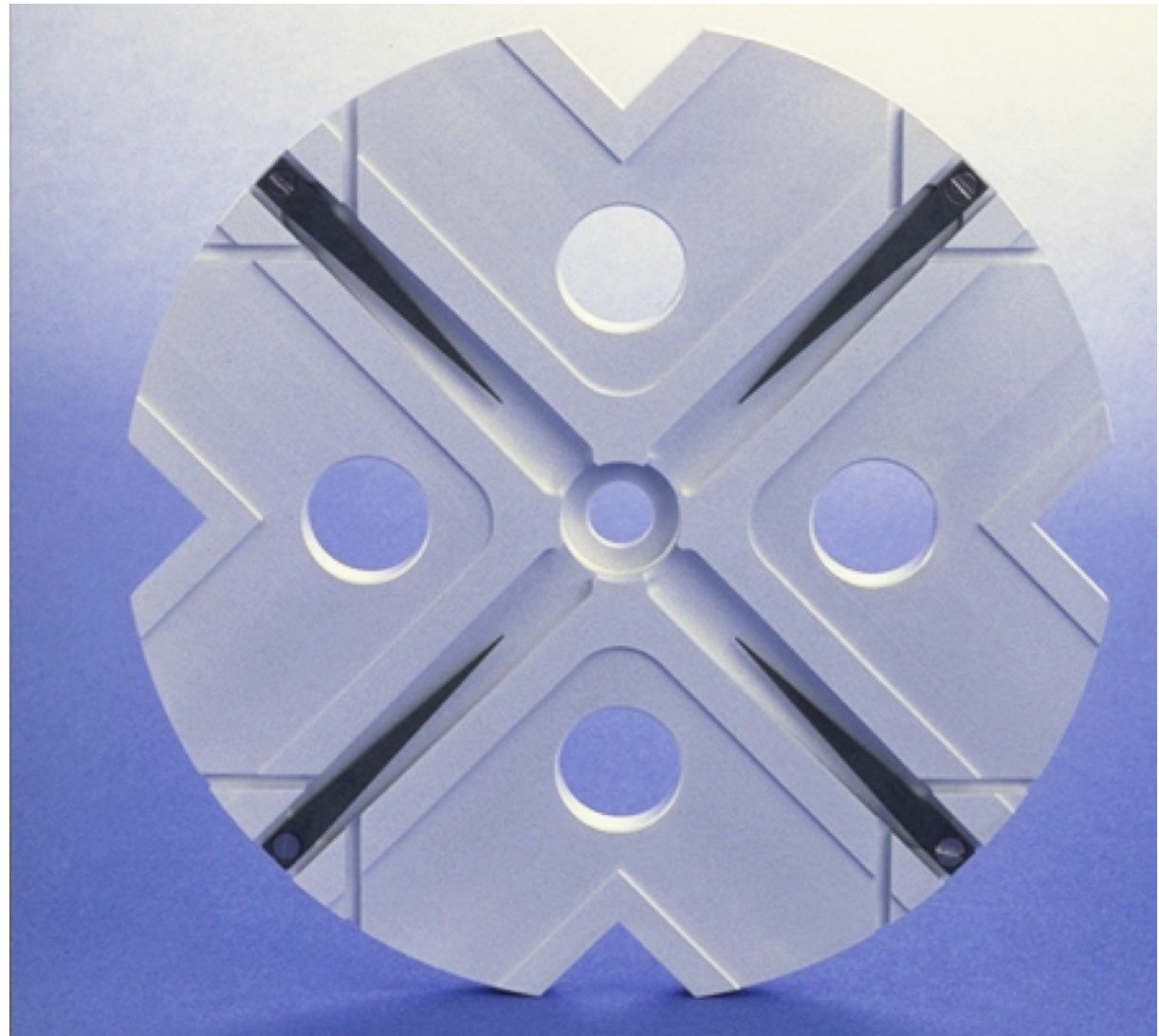

Effect of Damping

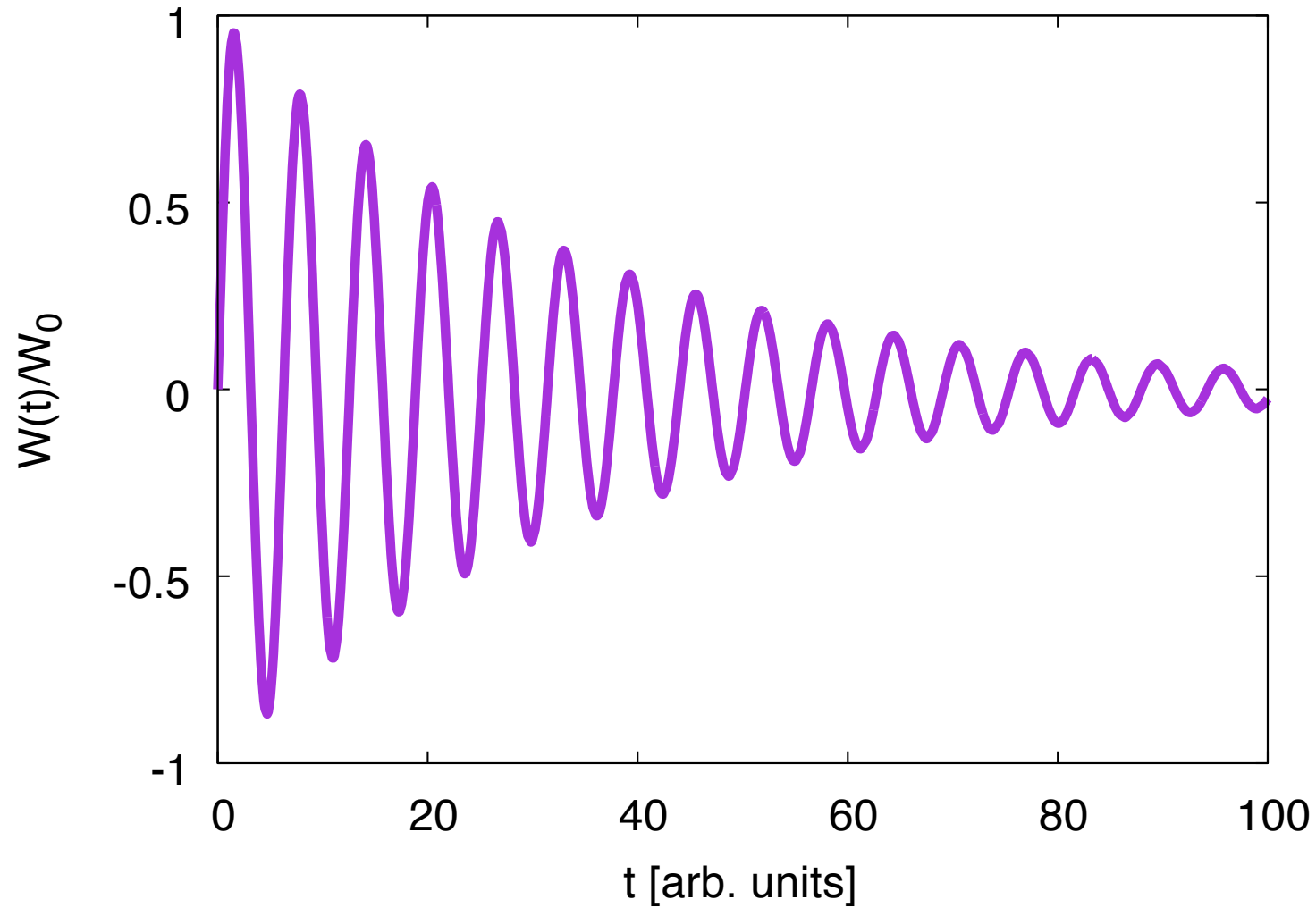

Detuning

To make our life simple we neglect damping

We split the wakefield $W(z) = W_0 \sin(kz)$ into two modes

$$W(z) = W_0 \frac{\sin((k + \Delta)z) + \sin((k - \Delta)z)}{2}$$

the resulting amplitude is

$$W(z) = W_0 \sin(kz) \cos(\Delta z)$$

Integrating over a Gaussian distribution yields

$$W(z) = W_0 \sin(kz) \int_0^\infty \frac{2}{\sqrt{2\pi}\sigma_\Delta} \exp\left(-\frac{\Delta^2}{2\sigma_\Delta^2}\right) \cos(\Delta z) d\Delta$$

$$\Rightarrow W(z) = W_0 \sin(kz) \exp\left(-\frac{(z\Delta)^2}{2}\right)$$

- For a limited number of modes, recoherence can occur
⇒ damping is also needed
- In ILC detuning is important

Effect of Detuning

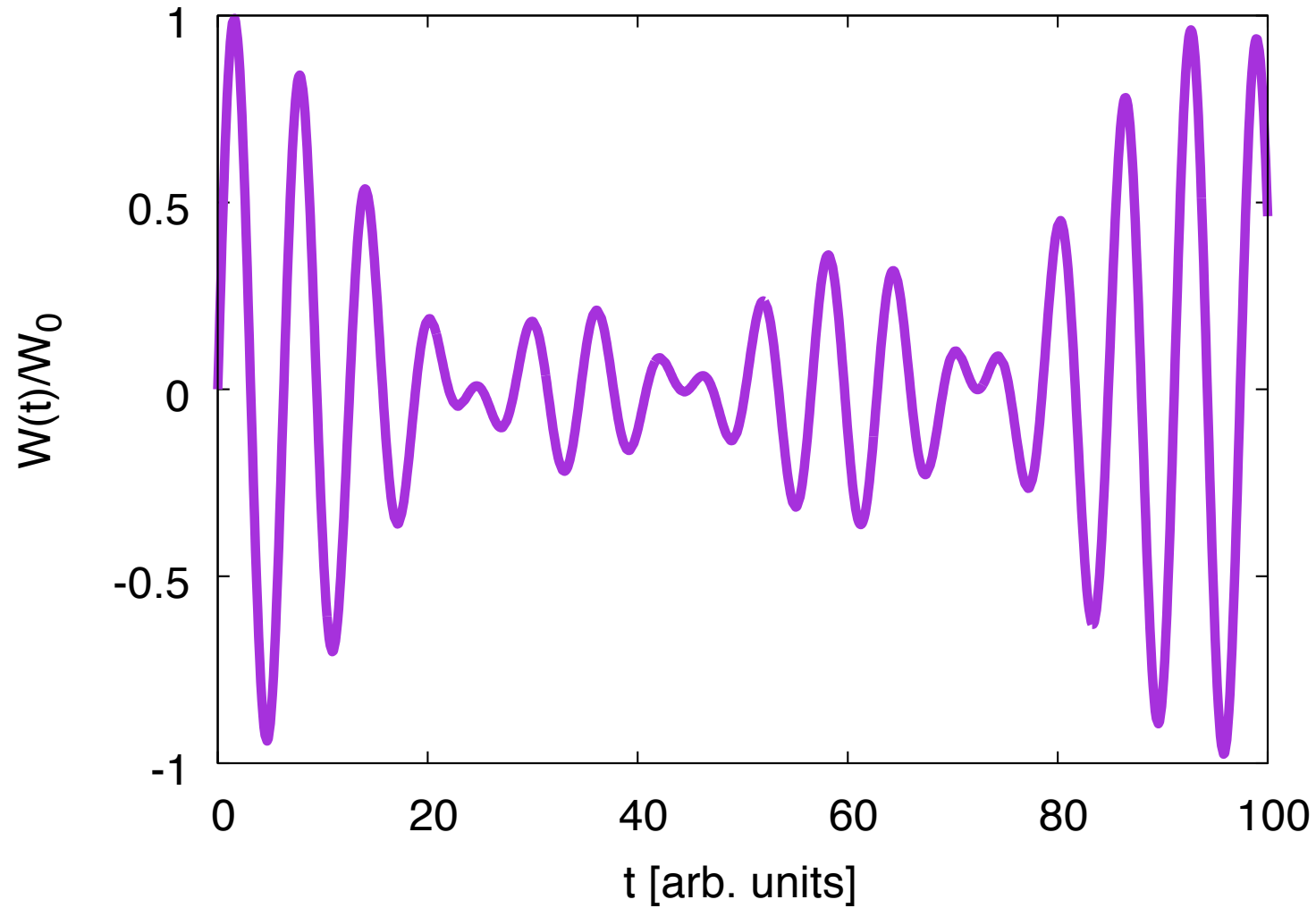

Effect of Both

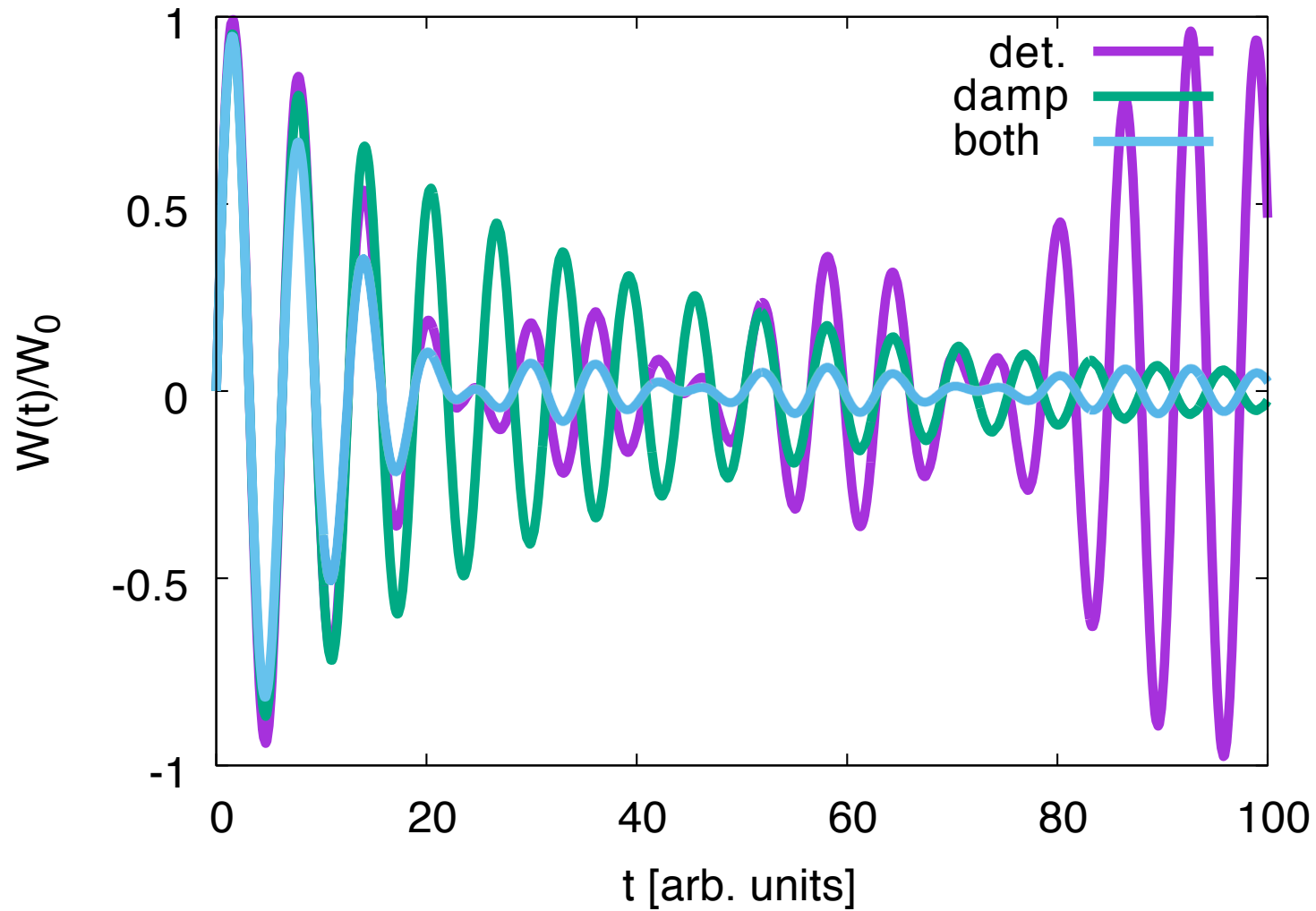

Multi-Bunch Jitter Emittance Growth (CLIC)

- Multi-bunch effects can be calculated analytically for point-like bunches
 - an energy spread leads to a more stable case
 - Simulations show
 - point-like bunches
 - Bunches with energy spread up to their length
 - Bunches also with initial energy spread
- ⇒ Point-like bunches is conservative model
- ⇒ Beam is stable enough

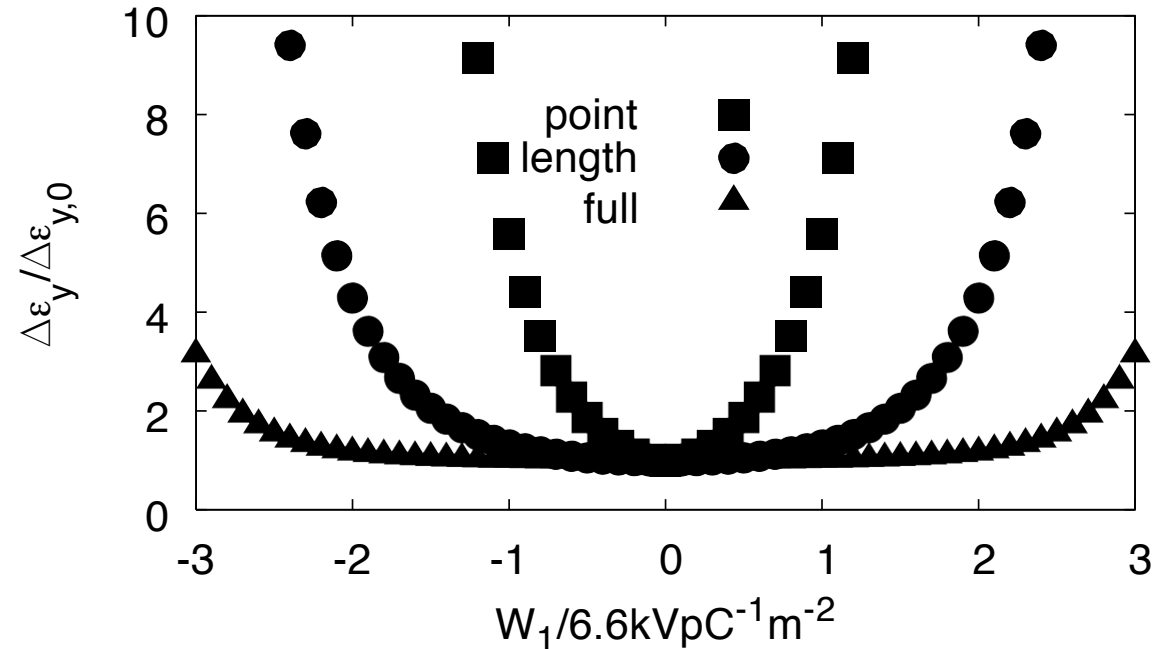

Static Multi-Bunch Effects (ILC)

Simulation of long-range transverse wakefield effects

- With no detuning
- With random detuning from cavity to cavity

All main linac cavities are scattered by $500 \mu\text{m}$

Long-range wakefields are represented by a number of RF modes

- ⇒ Cavity detuning is essential
- ⇒ Need to ensure it is present

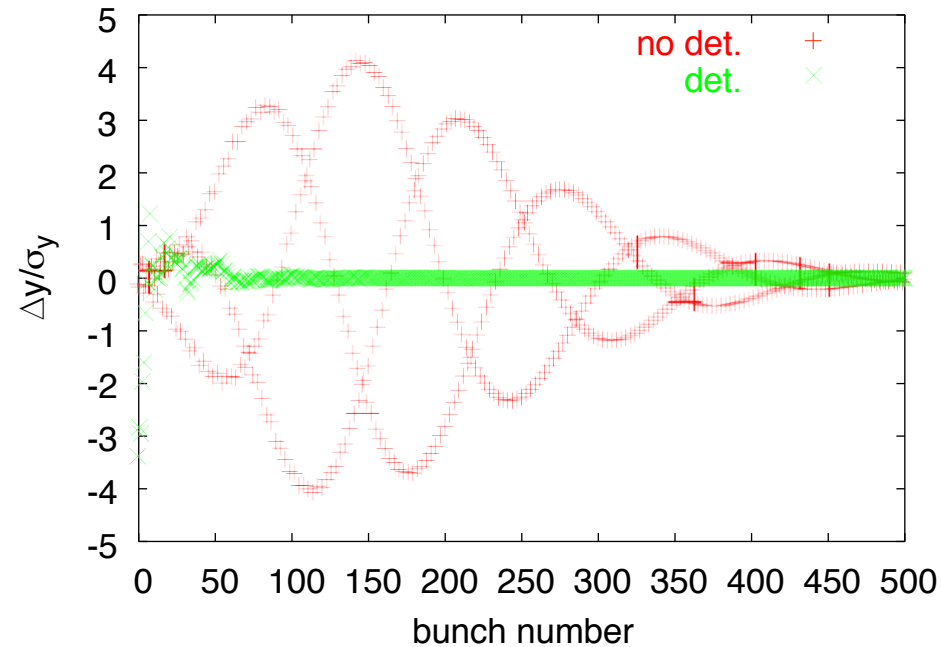

$$W_{\perp}(z) = \sum_{i=0}^n a_i \sin\left(\frac{2\pi z}{\lambda_i}\right) \exp\left(-\frac{\pi z}{\lambda_i Q_i}\right)$$

- Note: results depend on exact frequency of transverse modes
 - some uncertainty in the prediction
 - but not a worry with detuning

Beam Jitter (ILC)

- Perfect machines used
- 100 machines simulated
 - TESLA wakefields with 0.1% RMS frequency spread
- beam set to an offset
- 5% bunch-to-bunch charge variations in uncorrected test beam
- additional relative emittance growth due to multi-bunch is determined

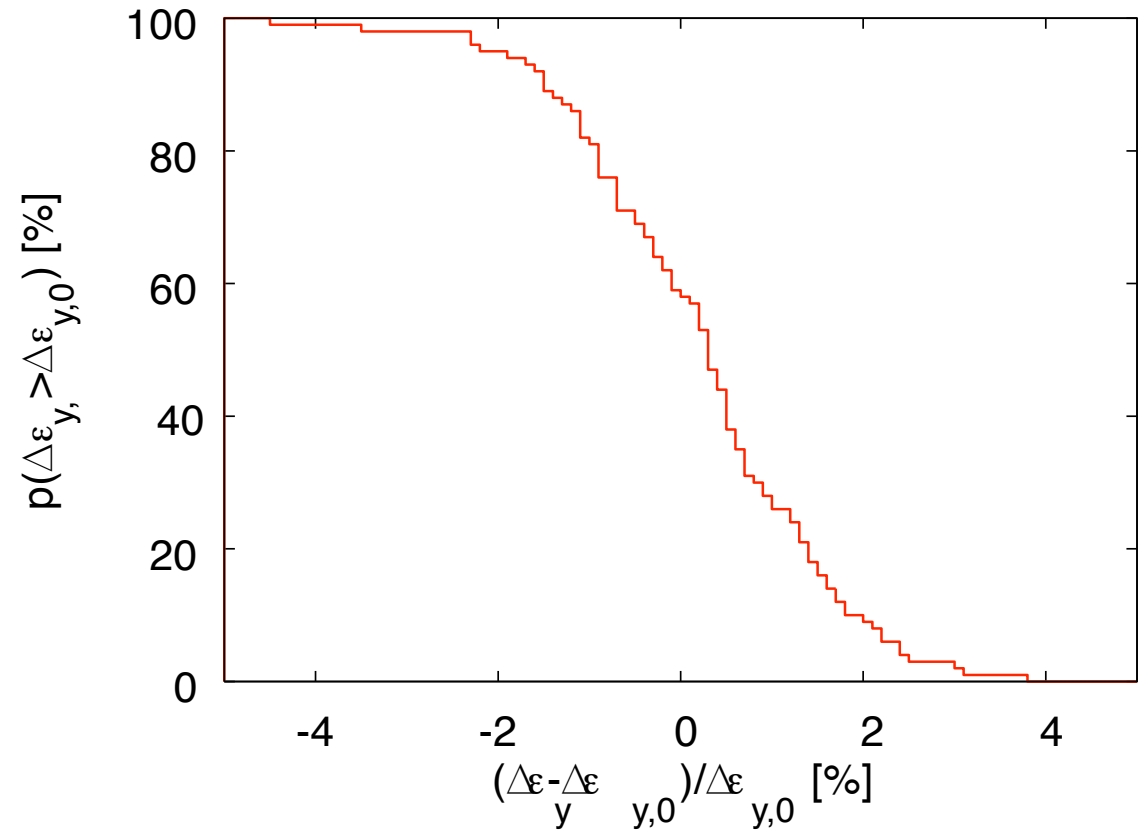

Normal Conducting FEL

- The minimum bunch spacing in an FEL is given by the ability to use the beam
- If bunches need to be separated into different lines need to have some nanoseconds spacing
 - and need one station per bunch
- Swiss FEL plans a couple of bunches per train
- Room for improvement

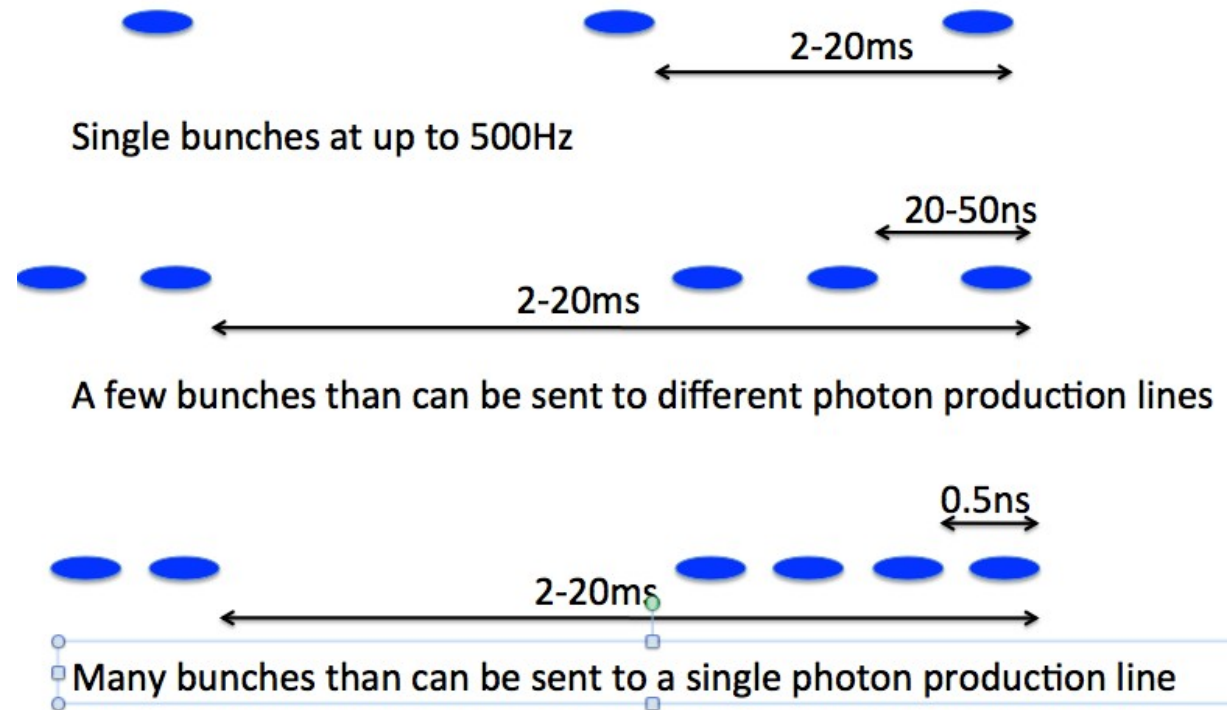

Imperfections



Introduction

- Have now been able to design a lattice that can transport the beam
- Need to determine how the imperfections in the machine affect the emittance preservation
- Will discuss the misalignment of elements
 - most important source of static emittance growth
- Have two ways to deal with tight tolerances for imperfections
 - work on the lattice to loosen tolerances
 - push R&D to satisfy tighter tolerances
 - e.g. in CLIC strong effort is ongoing to push imperfections down by about an order of magnitude

Element Misalignments

- Pre-Alignment imperfections can be roughly categorised into **short-distance** and **long-distance** errors
 - To first order, the imperfections can be treated as independent
 - as long as a linear main linac model is sufficient
 - The short-distance misalignments give largest emittance contribution
 - misalignment of elements is largely independent
 - simulated by scattering elements around a straight line
 - or slightly more complex local model
 - The long-distance misalignments are dominated by the wire system
- ⇒ ignore short-distance misalignments and simulate wire errors only
- Combined studies are mainly for completeness

Simulation Rational

- Script language used to steer the simulation
 - The art is in using minimum model
 - as little as possible
 - as much as necessary
 - One can understand the effects qualitatively
 - some can be calculated analytically
 - some can be approximated analytically
 - but things soon become complex
- ⇒ Beam dynamics tracking code is used for studies (choose your favorite one)
- Implemented models are usually very flexible
 - e.g. linear and non-linear effects
- ⇒ Cannot say what is in the code but rather what is in each individual study

Main Linac Static Tolerances

Element	error	with respect to	tolerance	
			CLIC	ILC
Structure	offset	beam	5.8 μm	$\approx 700 \mu\text{m}$
Structure	tilt	beam	220 μradian	$\approx 1000 \mu\text{radian}$
Quadrupole	offset	straight line	—	—
Quadrupole	roll	axis	240 μradian	190 μradian
BPM	offset	straight line	0.44 μm	15 μm
BPM	resolution	BPM center	0.44 μm	15 μm

- All tolerances for 1nm growth after one-to-one steering
- Goal is to have 90% of the machines achieve an emittance growth due to static effects of less than 5 nm

CLIC Survey Concept

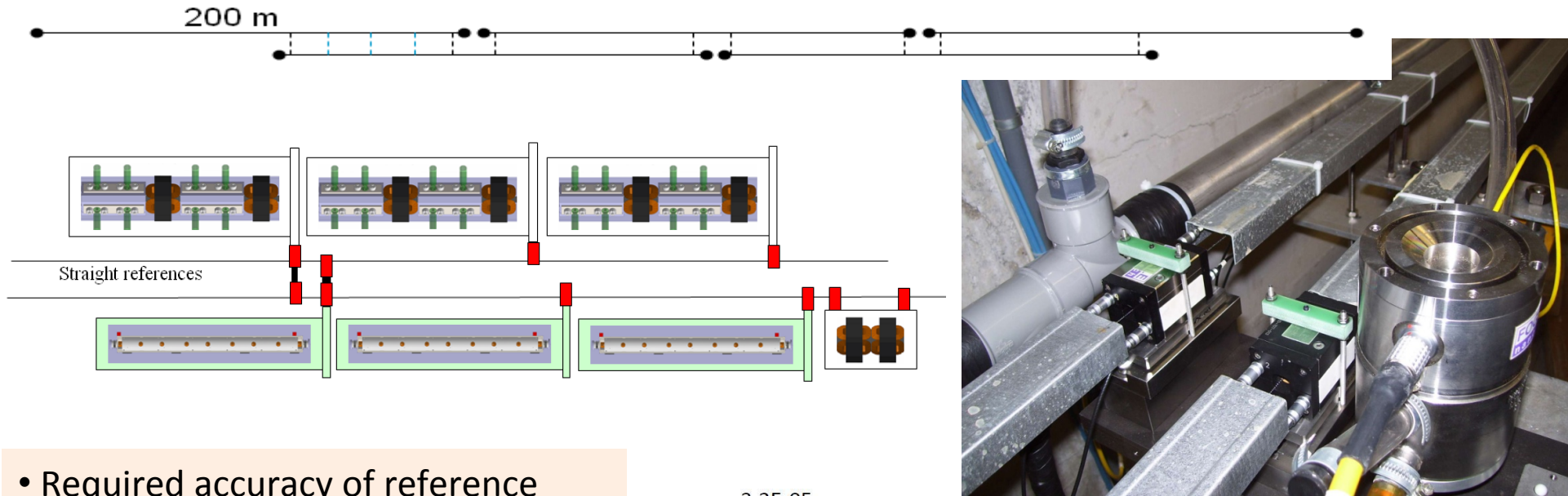

- Required accuracy of reference points is $10\mu\text{m}$

- Test of prototype shows
 - vertical RMS error of $11\mu\text{m}$
 - i.e. accuracy is approx. $13.5\mu\text{m}$

- Improvement path identified

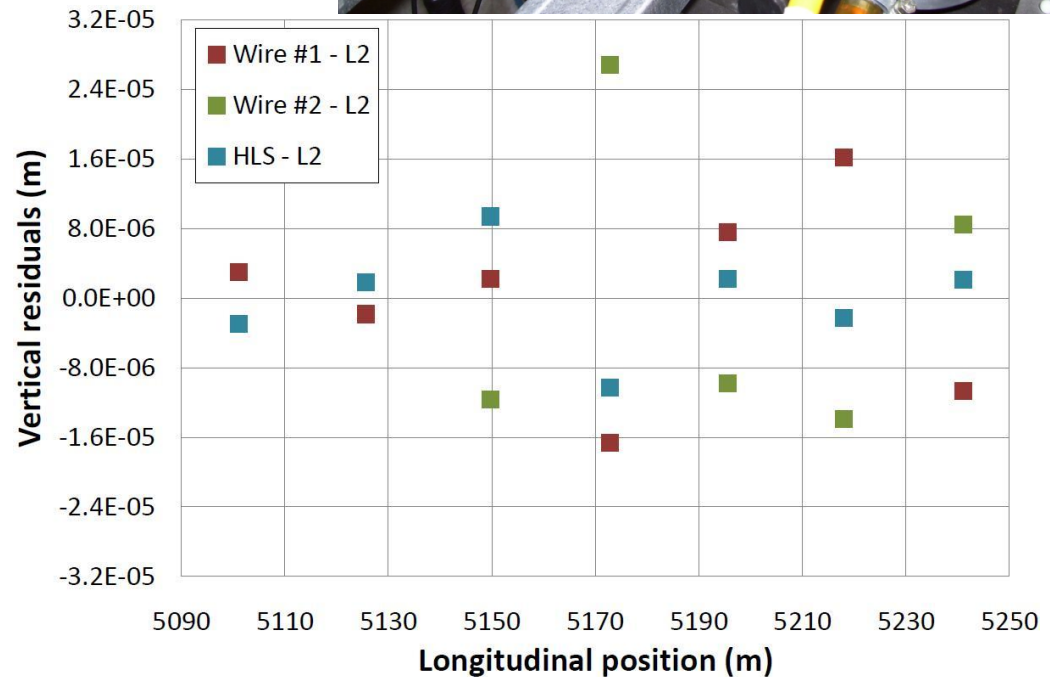

Assumed Survey Performance

Element	error	with respect to	alignment	
			ILC	CLIC
Structure	offset	girder girder	300 μm	5 μm
Structure	tilts	survey line	300 μradian	200(*) μm
Girder Girder	offset	survey line	200 μm	9.4 μm
Quadrupole	tilt	girder/survey line	20 μradian	9.4 μradian
Quadrupole	offset	survey line girder/	300 μm	17 μm
BPM	roll	survey line BPM	300 μradian	$\leq 100 \mu\text{radian}$
BPM	offset	center wake center	300 μm	14 μm
Wakefield mon.	resolution		$\approx 1 \mu\text{m}$	0.1 μm
	offset		—	5 μm

- In ILC specifications have much larger values than in CLIC
 - more difficult alignment in super-conducting environment
 - dedicated effort for CLIC needed
- Wakefield monitors are currently only foreseen in CLIC
 - but could be an option also in ILC

Beam-Based Alignment and Tuning Strategy

- Make beam pass linac
 - one-to-one correction
- Remove dispersion, align BPMs and quadrupoles
 - dispersion free steering
 - ballistic alignment
 - kick minimisation
- Remove residual wakefield and dispersive effects
 - accelerating structure alignment (CLIC only)
 - emittance tuning bumps
- Tune luminosity
 - tuning knobs

Dispersion Free Correction

- Basic idea: use different beam energies
- NLC: switch on/off different accelerating structures
- CLIC (ILC): accelerate beams with different gradient and initial energy
 - try to do this in a single pulse (time resolution)
- Optimise trajectories for different energies together:

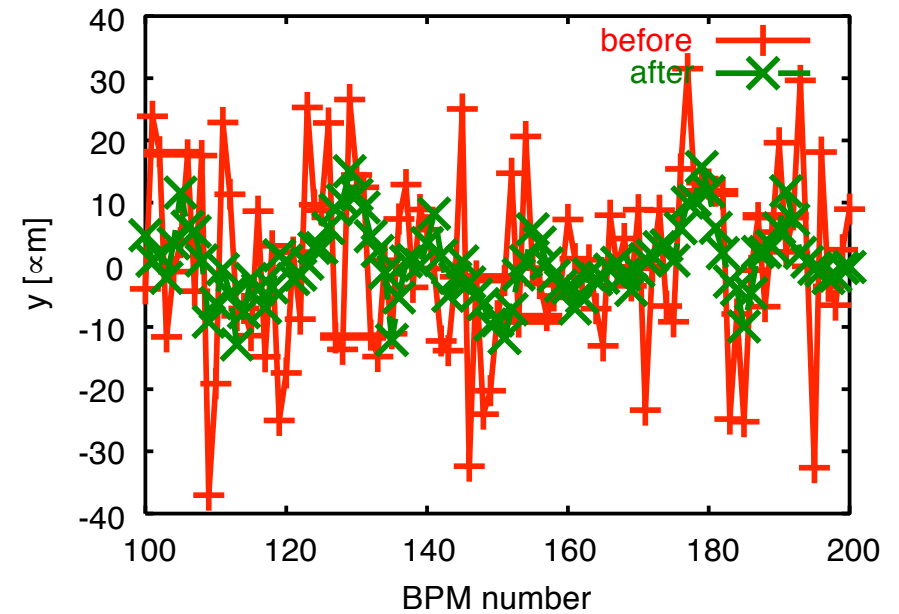

$$S = \sum_{i=1}^n \left(w_i (x_{i,1})^2 + \sum_{j=2}^m w_{i,j} (x_{i,1} - x_{i,j})^2 \right) + \sum_{k=1}^l w'_k (c_k)^2$$

- Last term is omitted
- Idea is to mimic energy differences that exist in the bunch with different beams

Emittance Growth (ILC)

Error	with respect to	value	$\Delta\varepsilon_y$ [nm]	$\Delta\varepsilon_{y,121}$ [nm]	$\Delta\varepsilon_{y,dfs}$ [nm]
Cavity offset	module	300 μm	3.5	0.2	0.2(0.2)
Cavity tilt	module	300 μradian	2600	< 0.1	1.8(8)
BPM offset	module	300 μm	0	360	4(2)
Quadrupole offset	module	300 μm	700000	0	0(0)
Quadrupole roll	module	300 μradian	2.2	2.2	2.2(2.2)
Module offset	perfect line	200 μm	250000	155	2(1.2)
Module tilt	perfect line	20 μradian	880	1.7	—

- The results of the reference DFS method is quoted, results of a different implementation in brackets
- Note in the simulations the correction the quadrupoles had been shifted, other wise some residual effect of the quadrupole misalignment would exist

Beam-Based Structure Alignment (CLIC)

- Each structure is equipped with a wakefield monitor (RMS position error $5 \mu\text{m}$)
 - Up to eight structures on one movable girders
- ⇒ Align structures to the beam
- Assume identical wake fields
 - the mean structure to wakefield monitor offset is most important
 - in upper figure monitors are perfect, mean offset structure to beam is zero after alignment
 - scatter around mean does not matter a lot
 - With scattered monitors
 - final mean offset is σ_{wm}/\sqrt{n}
 - In the current simulation each structure is moved independently
 - A study has been performed to move the articulation points

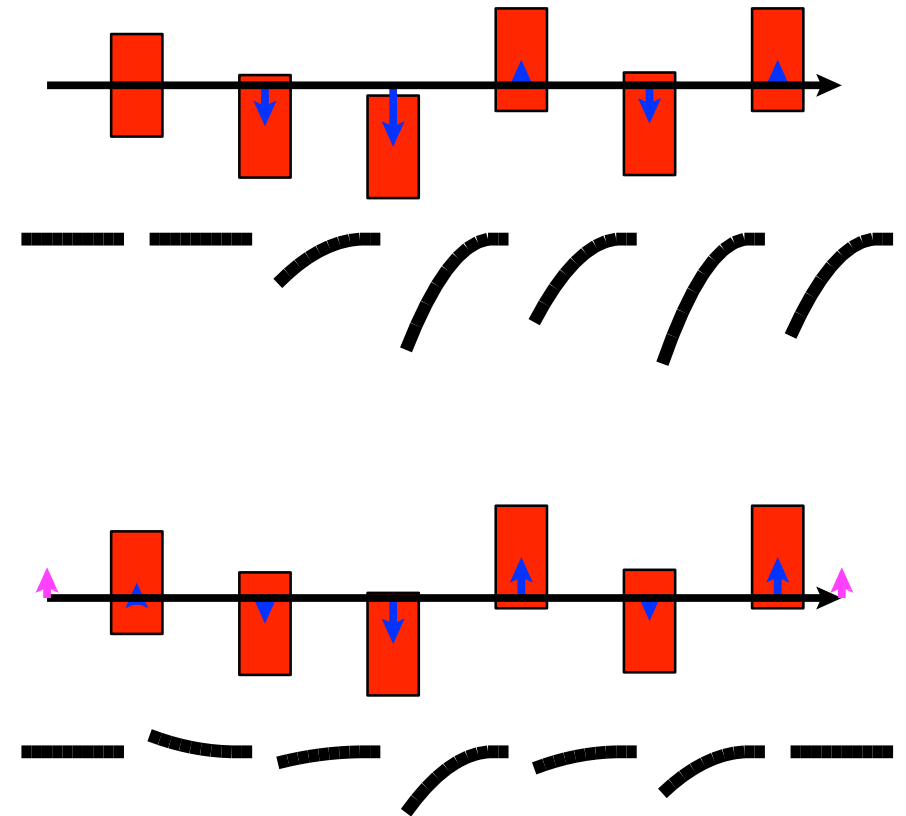

- For our tolerance $\sigma_{wm}=5\mu\text{m}$ we find $\Delta\varepsilon_y \approx 0.5 \text{ nm}$
- Some dependence on alignment method

Emittance Tuning Bumps

- Emittance (or luminosity) tuning bumps can further improve performance

- globally correct wake-field by moving some structures
- similar procedure for dispersion

- Need to monitor beam size

- Optimisation procedure

- measure beam size for different bump settings
- make a fit to determine optimum setting
- apply optimum
- iterate on next bump

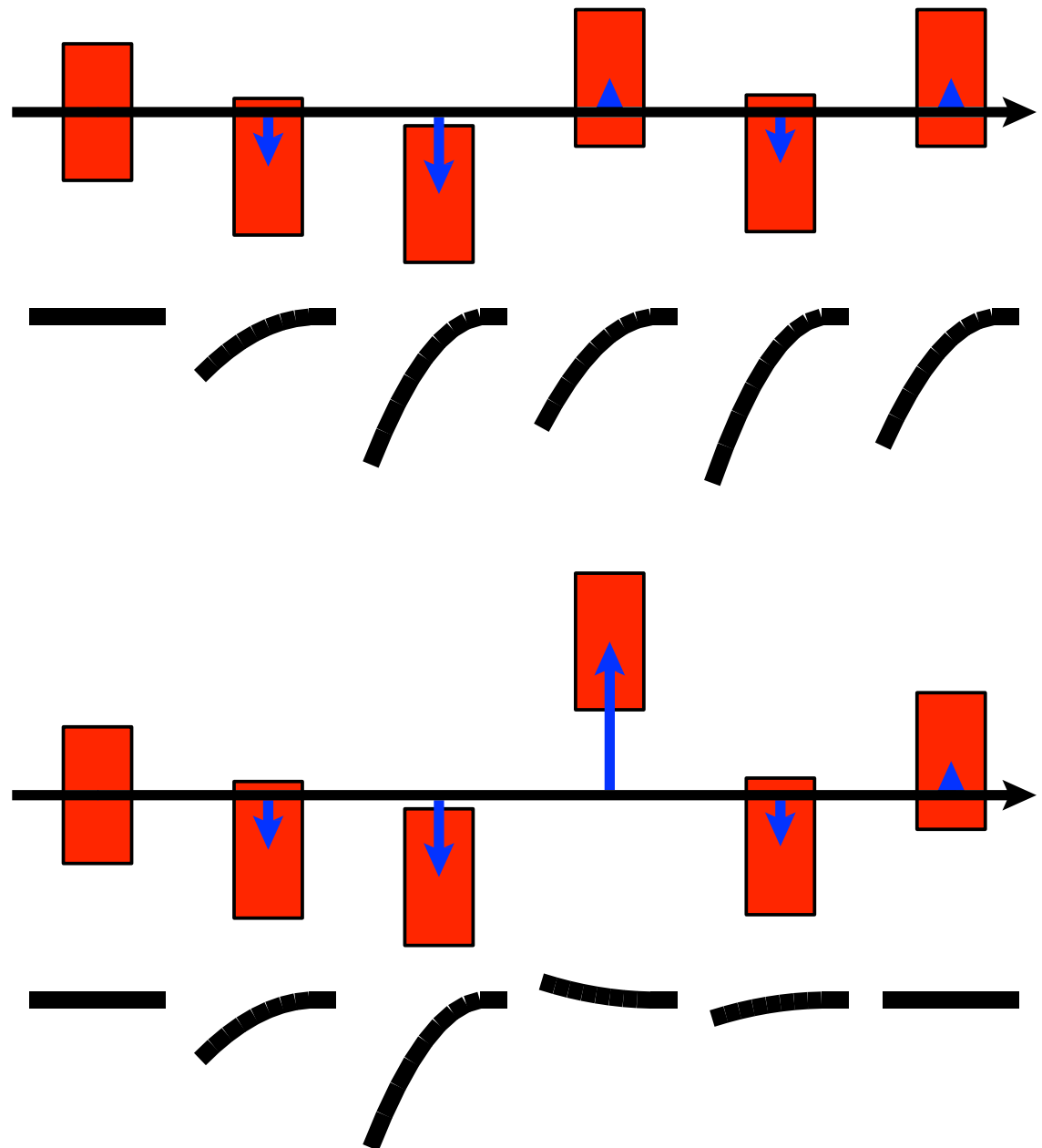

Final Emittance Growth (CLIC)

imperfection	with respect to	symbol	value	emitt. growth
BPM offset	wire reference	σ_{BPM}	$14 \mu\text{m}$	0.367 nm
BPM resolution		σ_{res}	$0.1 \mu\text{m}$	0.04 nm
accelerating structure offset	girder axis	σ_4	$10 \mu\text{m}$	0.03 nm
accelerating structure tilt	girder axis	σ_t	$200 \mu\text{radian}$	0.38 nm
articulation point offset	wire reference	σ_5	$12 \mu\text{m}$	0.1 nm
girder end point	articulation point	σ_6	$5 \mu\text{m}$	0.02 nm
wake monitor	structure centre	σ_7	$5 \mu\text{m}$	0.54 nm
quadrupole roll	longitudinal axis	σ_r	$100 \mu\text{radian}$	$\approx 0.12 \text{ nm}$

- Multi-bunch wakefield misalignments of $10 \mu\text{m}$ lead to $\Delta\varepsilon_y \approx 0.13 \text{ nm}$
 - ⇒ Can reach emittance preservation goal
 - ⇒ Would be worse with higher charge

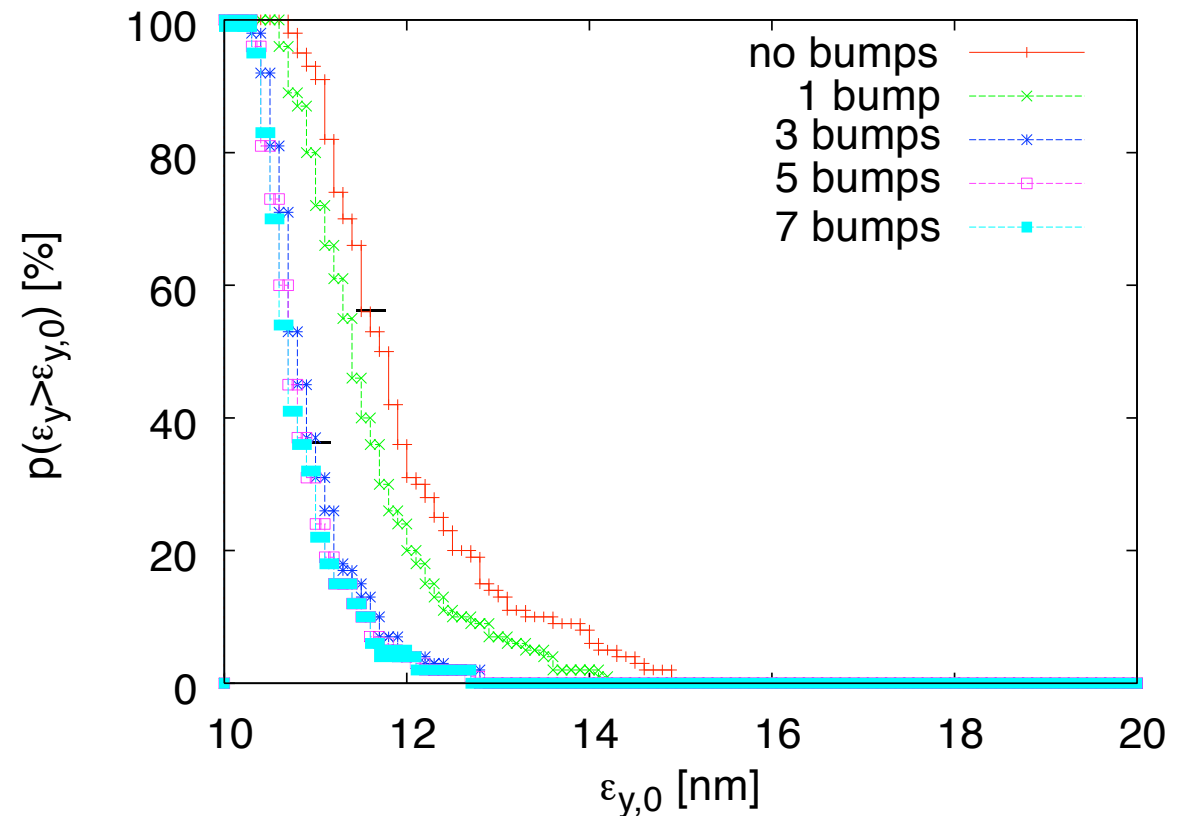

Results (ILC)

- DFS brings us close to the required performance
- Tuning of the dispersion helps a lot
- Even wakefield tuning helps us
- The remaining emittance growth is to a significant extent due to quadrupole roll
 - ⇒ Should add corresponding tuning bump

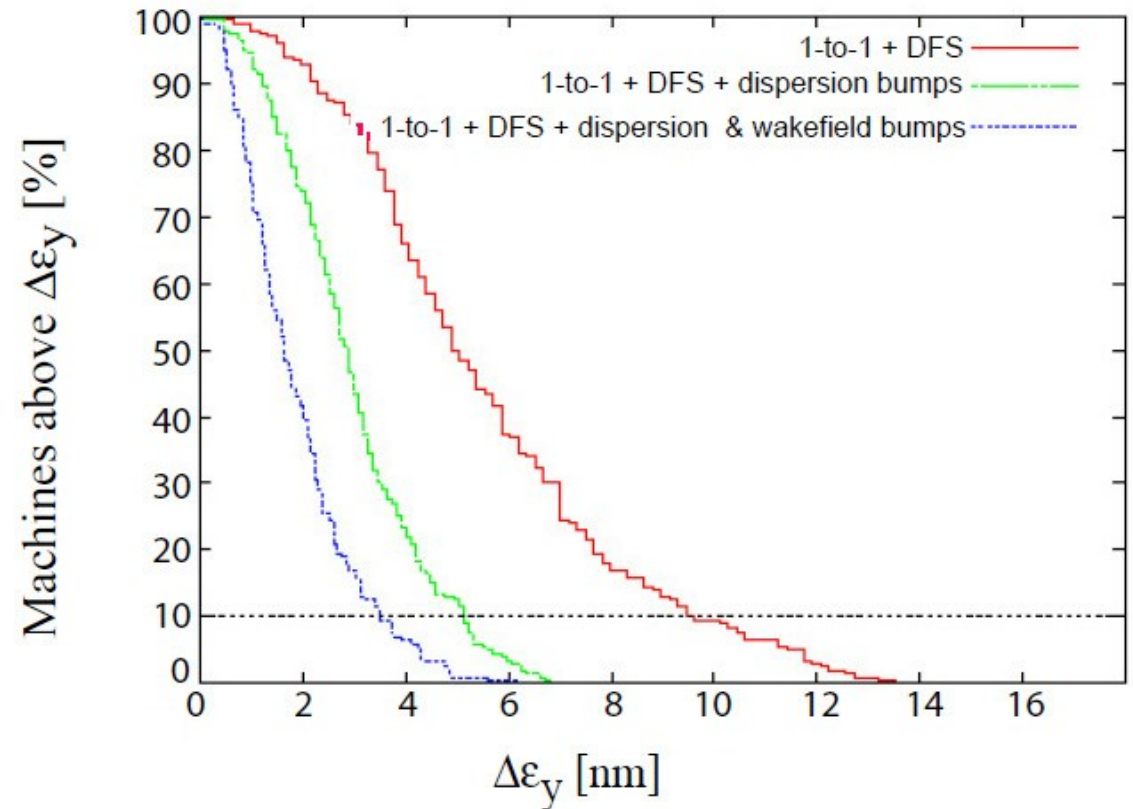

Dependence on Weights (Old CLIC Parameters)

- For TRC parameters set
- One beam is used with different gradient and different incoming energy

⇒ BPM position errors are less important with larger w_1
⇒ BPM resolution less important for small w_1
⇒ Need a compromise

⇒ There is no such thing as **the tolerance**

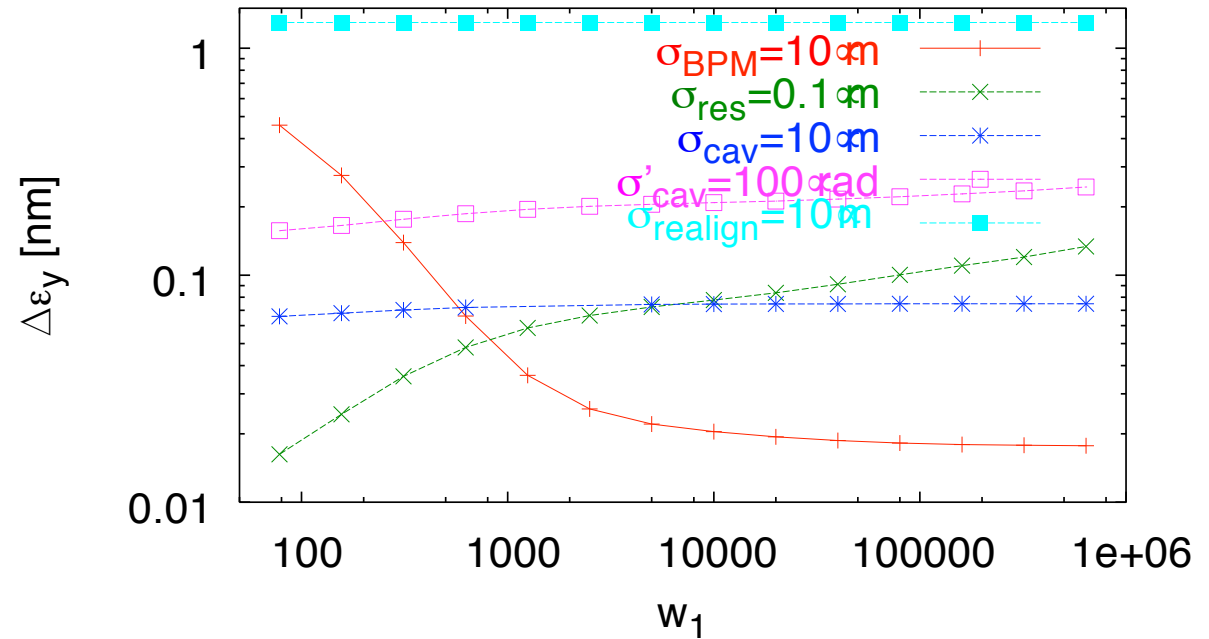

Growth Along Main Linac (CLIC)

- Emittance growth along the main linac due to different imperfections
- Growth is mainly constant per cell
 - follows from first principles applied during lattice design
- Exception is structure tilt
 - due to uncorrelated energy spread
 - flexible weight to be investigated
- Some difference for BPMs
 - due to secondary emittance growth

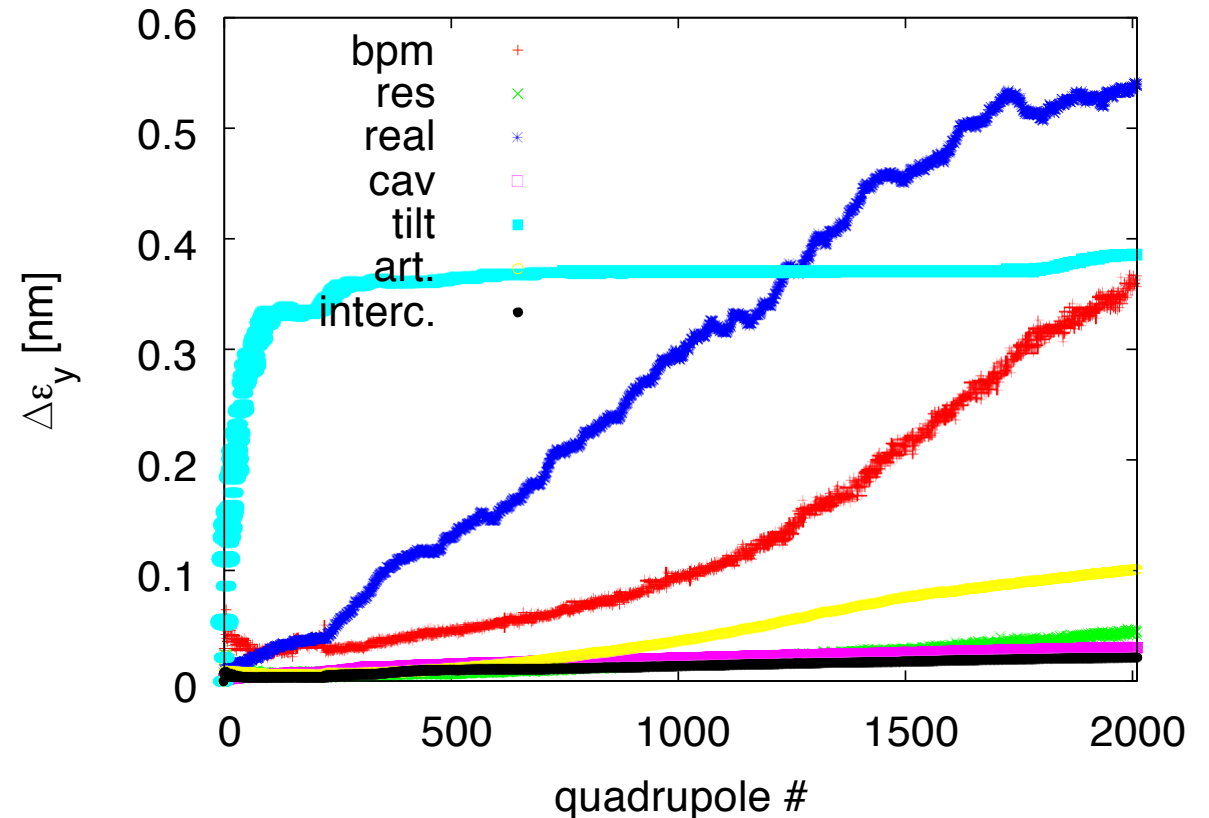

Sensitivity to Survey Line Errors (CLIC)

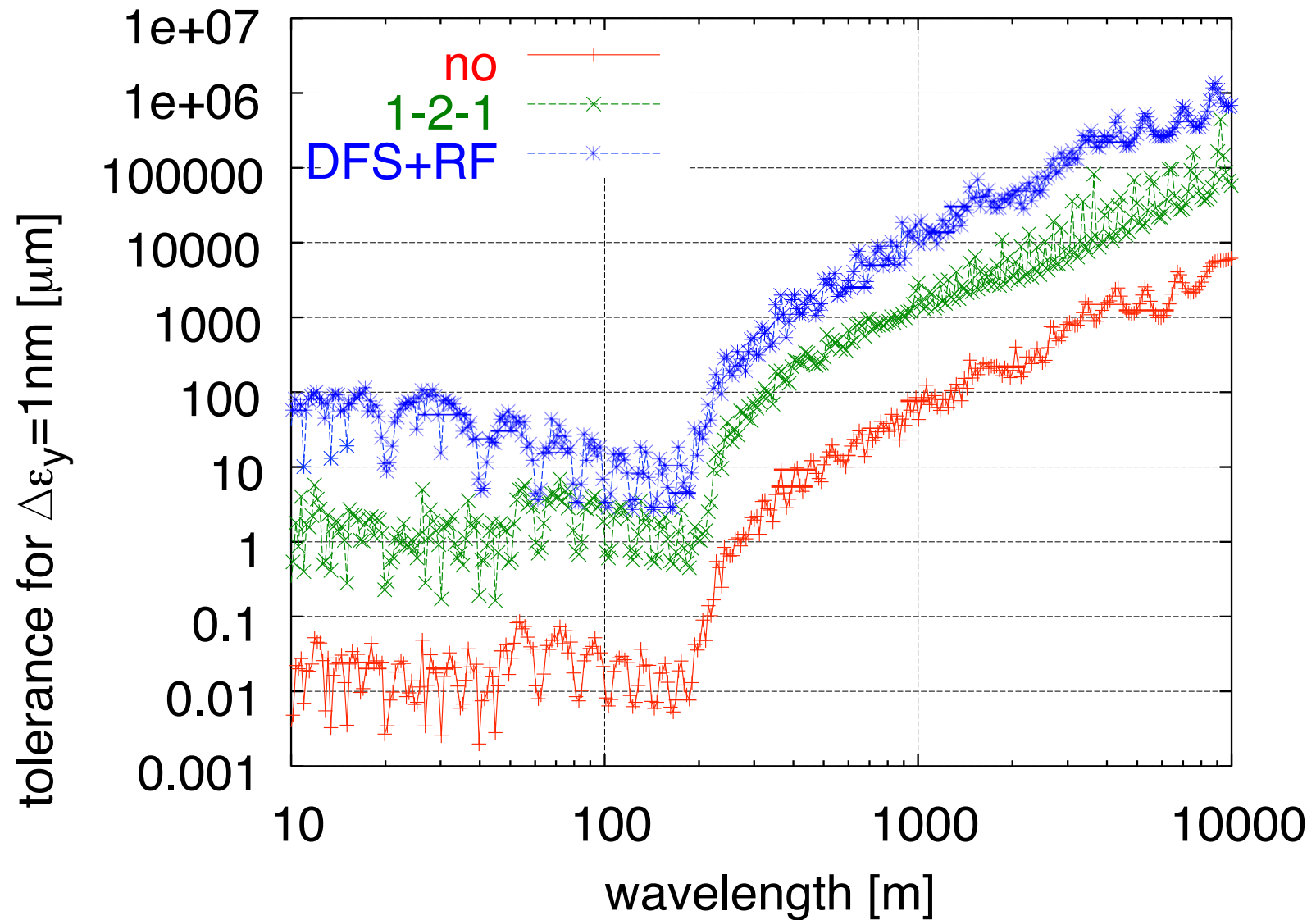

- Cosine-line misalignments, beta-functions clearly visible

CLIC Beam-Based Alignment Tests at FACET)

A. Latina,
J. Pfingstner,
E. Adli,
D. Schulte

DFS correction applied to 500 meters of the SLC linac

- SysID algorithms for model reconstruction
- DFS correction with GUI
- Emittance growth is measured

Graphic User Interface:

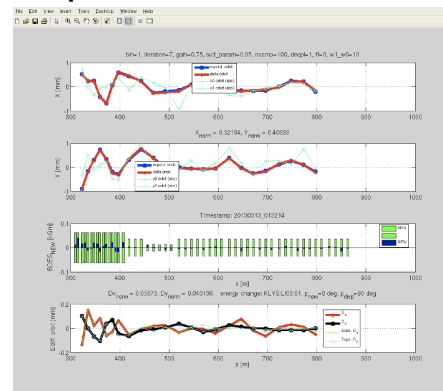

Beam profile measurement

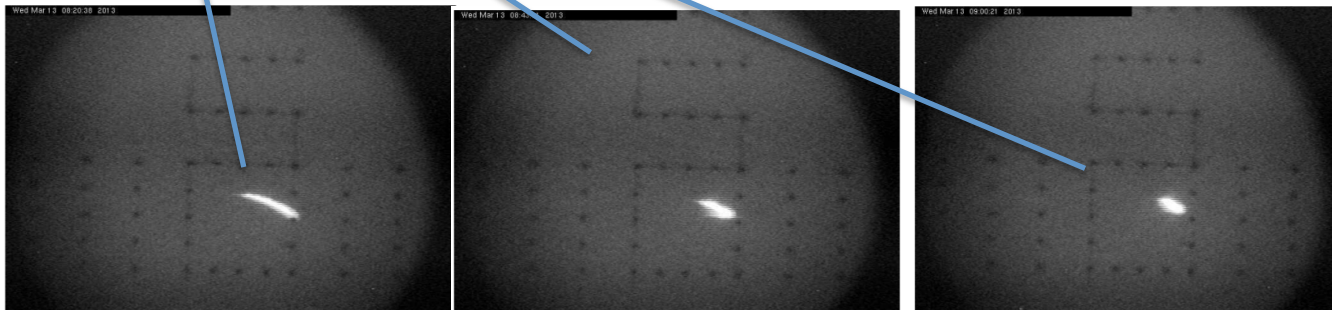
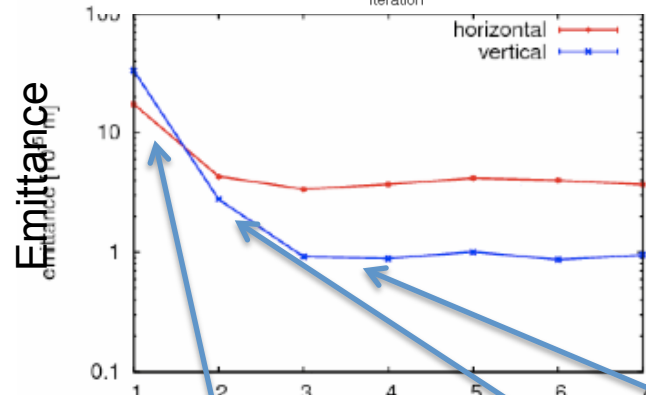
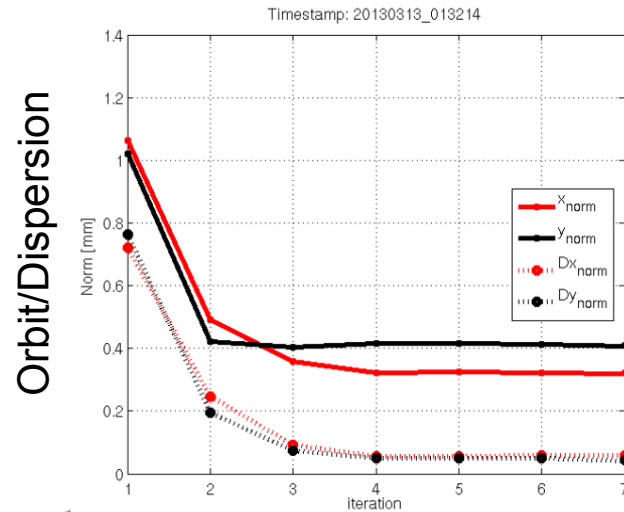
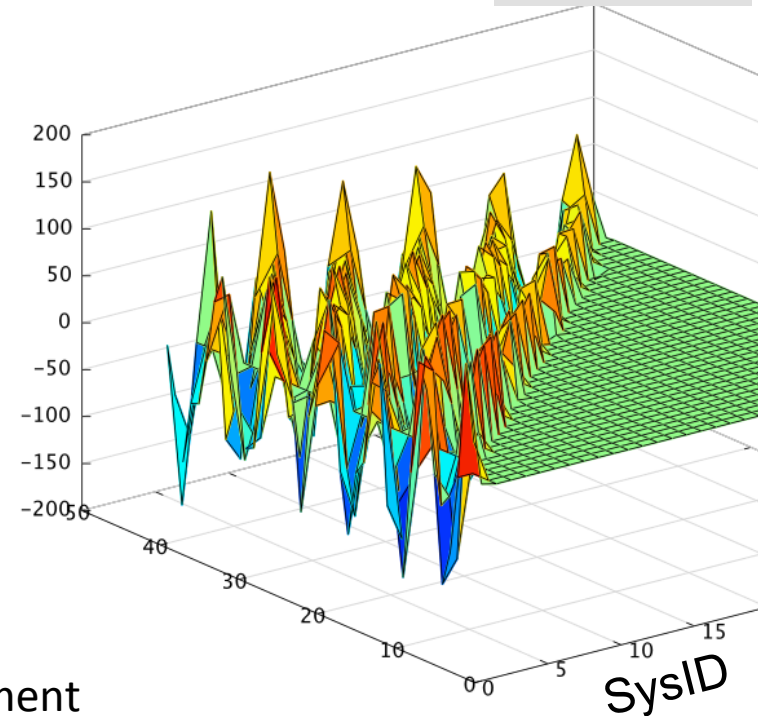

After 1 iteration

After 3 iterations

Incoming oscillation/
dispersion is taken out and
flattened; emittance in LI11
and emittance growth
significantly reduced.

Energy Stability

Not to be forgotten



Requirements

- The final energy needs to be accurately known for physics
 - measurement
- The final energy needs to be stable for physics
 - large energy variations would also cause luminosity loss due to limited BDS band- width
 - need to control final energy
- The emittance needs to be preserved in presence of static imperfections
 - differences between the actual and the assumed lattice can cause emittance growth
 - need to control energy profile
- The emittance needs to be preserved in presence dynamic of imperfections
 - the energy profile needs to be stable
 - kicks due to cavity tilts need to be controlled
- Beam timing errors lead to luminosity loss
 - need to control bunch compressor RF stability

Main Linac RF Noise Sources (ILC)

- Lorentz force detuning
 - systematic from pulse to pulse
 - is largely corrected using piezo tuners in feed-forward
- Microphonics
 - unpredictable
 - corrected by klystron-based (or piezo-based) feedback
- Klystron amplitude and phase jitter
 - corrected by klystron based feedback
- Beam current variation
 - measure beam current at damping ring and use feed-forward for klystrons
- Feedback noise
 - measurement noise
 - feedback amplifies at some frequencies
- Jitter of timing reference
 - impacts feedback systems

Low Level RF Controls

- The low level RF control ties the RF phase to a timing reference and adjusts the gradient
- For each cavity one measures
 - field amplitude and phase
 - input power
 - reflected power
- As correctors are used
 - piezo tuners in each cavity
 - stepping motors
 - klystron amplitude and phase
- One needs a beam timing feedback
- The klystron-based feedback acts on the vector sum of all cavity gradients in a unit
- The sensors are calibrated measuring the field with and without beam
 - the field induced by the beam can be calculated
- Input and reflected power per cavity is measured
- Beam current is measured at damping ring and used for feed-forward

CLIC RF Jitter Tolerance

- RF gradient and phase errors lead to final beam energy errors
 - The BDS bandwidth is limited
- ⇒ Lose luminosity
- RF tolerances translate directly into drive beam current and phase tolerances

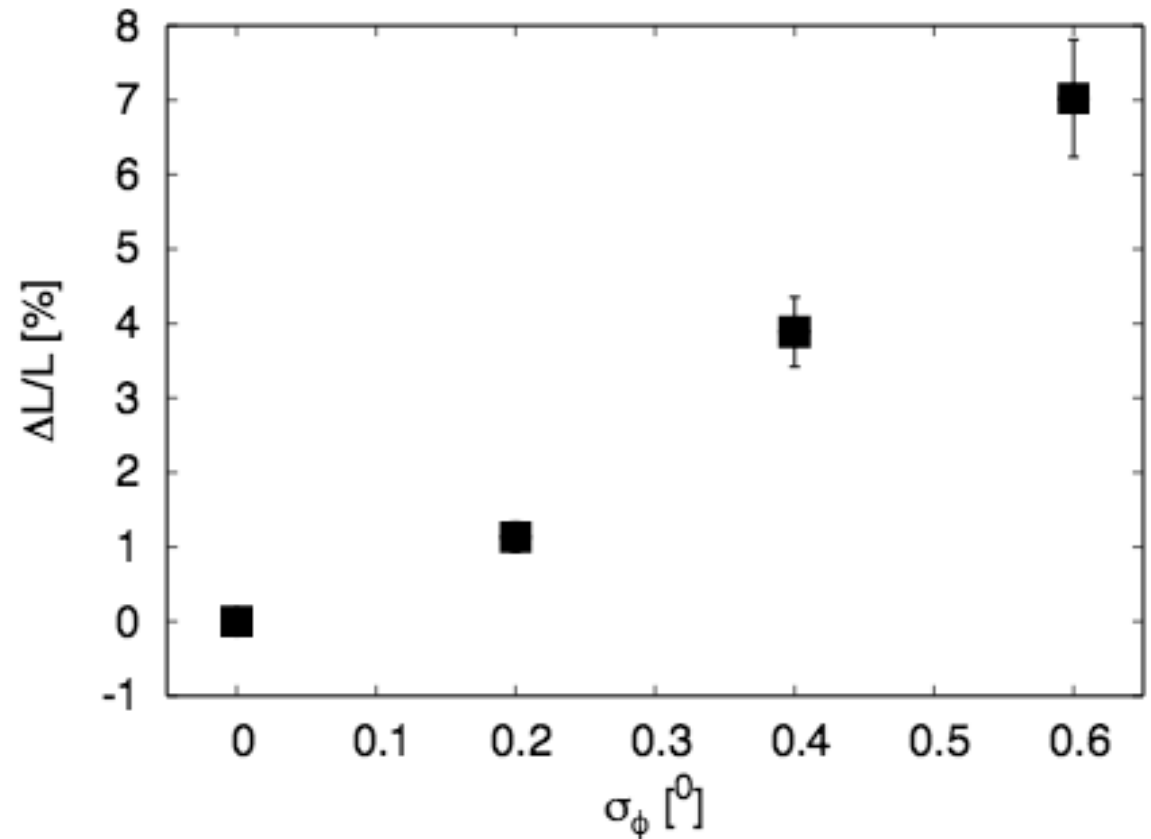

$$\frac{\Delta \mathcal{L}}{\mathcal{L}} \approx 0.01 \left[\left(\frac{\sigma_{\phi,coh}}{0.2^\circ} \right)^2 + \left(\frac{\sigma_{\phi,inc}}{0.8^\circ} \right)^2 + \left(\frac{\sigma_{G,coh}}{0.75 \cdot 10^{-3}G} \right)^2 + \left(\frac{\sigma_{G,inc}}{2.2 \cdot 10^{-3}G} \right)^2 \right]$$

CLIC Layout

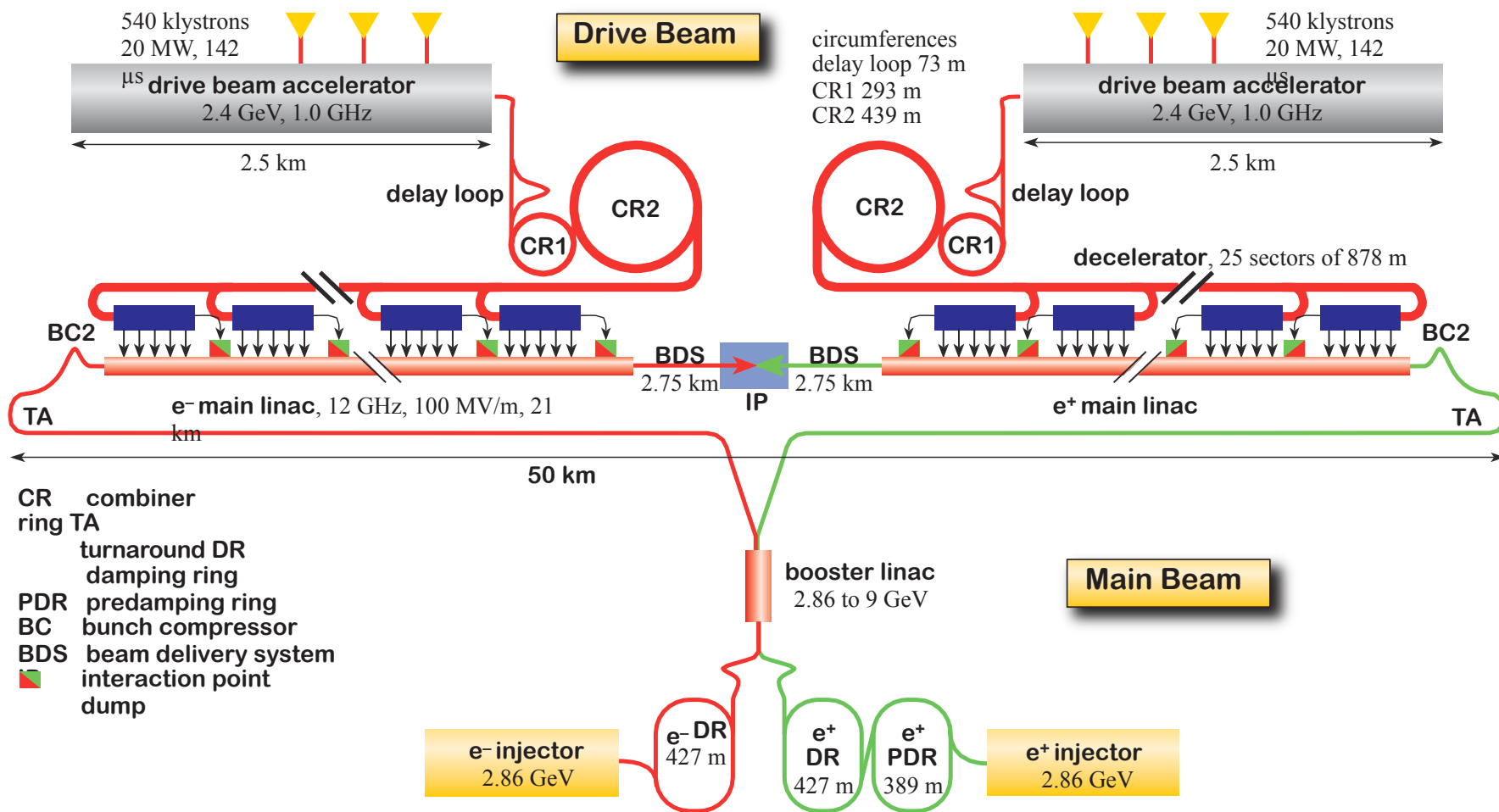

Phase Feed-forward

- Design drive beam complex for current and phase stability
 - Measured current stability is OK
 - Phase stability needs a factor to improvement

- ⇒ Correct the phase of the drive beam at the final turn-around
- requires timing reference system
 - but gives the missing factor

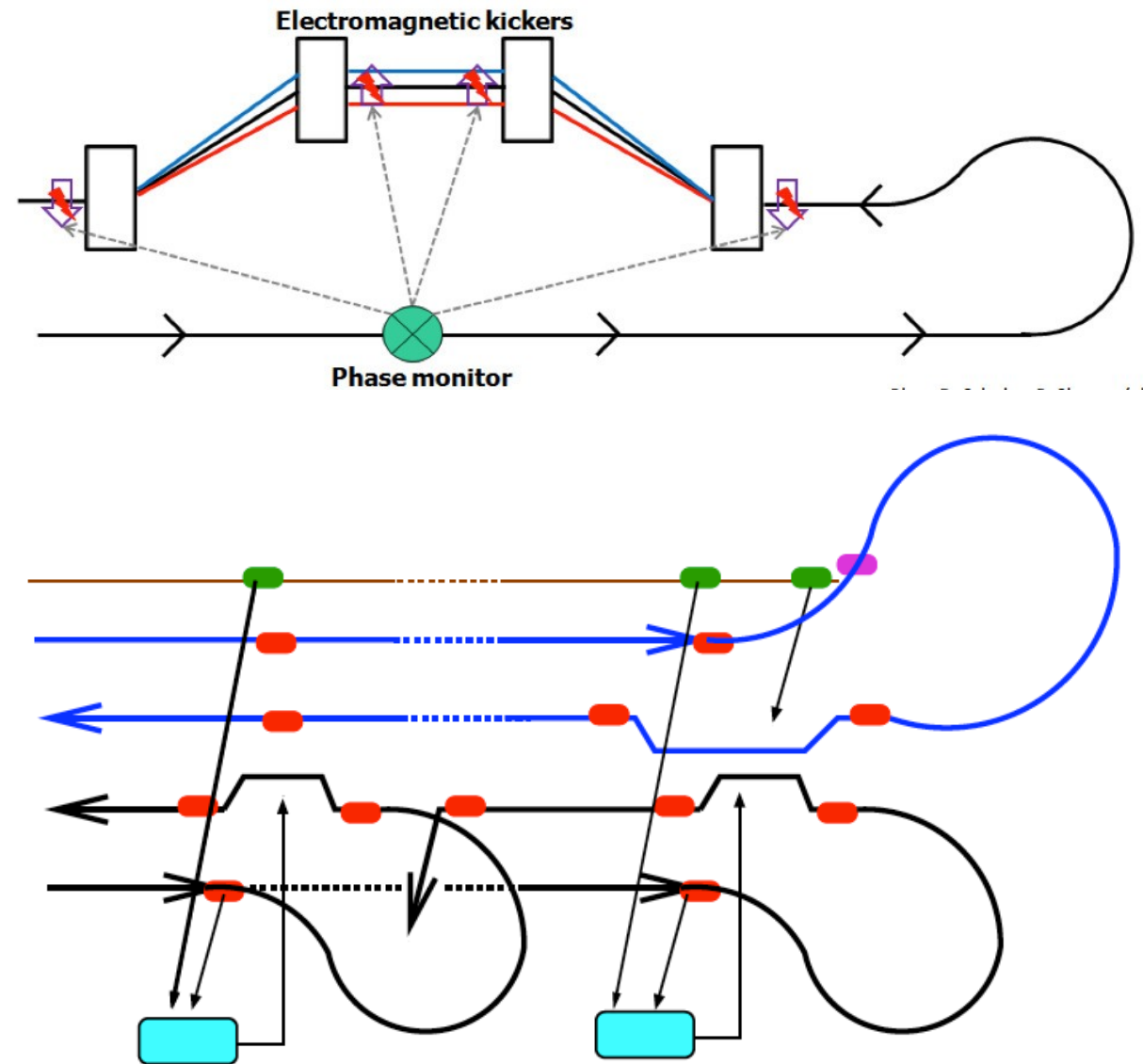

Conclusion

- Introduced some basic physics of the main linac
- For CLIC aim to maximise the beam current for best efficiency
 - leads to short pulses
 - requires drive beam scheme
- For ILC can afford using longer pulses
 - but still need pulsed operation
- Superconducting FELs could be operated in CW mode
- Normalconducting FELs need to find ways to use bunch trains

Thanks



- Many thanks to you for listening and to the people who helped me to prepare this lecture
 - with advice
 - with plots

Erik Adli, Alexej Grudiev, Erk Jensen, Jochem Snuverink, Igor Syratcev, Rolf Wegner, Walter Wuensch, Riccardo Zennaro, Frank Zimmermann

Some Fundamental Parameters

parameter	symbol	SLC	ILC	CLIC
centre of mass energy	E_{cm} [GeV]	92	500	3000
luminosity	L [10^{34} cm ⁻² s ⁻¹]	0.0003	1.8	5.9
luminosity in peak	$L_{0.01}$ [10^{34} cm ⁻² s ⁻¹]	0.0003	1.1	2
gradient	G [MV/m]	20	31.5	100
charge per bunch	N [10^9]	37	20	3.72
bunch length	σ_z [μ m]	1000	300	44
beam size	$\sigma_{x,y}$ [nm]	1700/600	474/5.9	40/1
vertical emittance	y [nm]	3000	35	20
bunches per pulse	n_b	1	1312	312
distance between bunches	Δ_b [ns]	–	554	0.5
repetition frequency	f_r [Hz]	120	5	50
average beam power	[MW]		10.5	28
peak beam power	[GW]		2.9	3600

⇒ Beam Parameters are very different

- We will see that this is driven by the main linac