

Very forward calorimeters for future electron-positron colliders



Ivan Smiljanić

Vinča Institute of Nuclear science, University of Belgrade, Serbia

[on behalf of FCAL Collaboration]

Forward region in future electron-positron colliders

Two specialized calorimeters foreseen:

- **LumiCal** - precise luminosity measurement;
- **BeamCal** - fast luminosity estimate and beam parameters control.

Both calorimeters improve the hermeticity of the main detector at very small polar angles.

Parameters	ILD	CLICdet
LumiCal geometrical acceptance [mrad]	31-77	38-110
fiducial acceptance [mrad]	41-67	44-80
z (from IP) [mm]	2480	2539
number of layers (W+Si)	30	40
BeamCal geometrical acceptance [mrad]	5-40	10-40
z (from IP) [mm]	3200	3181
number of layers (W+sensor)	30	40

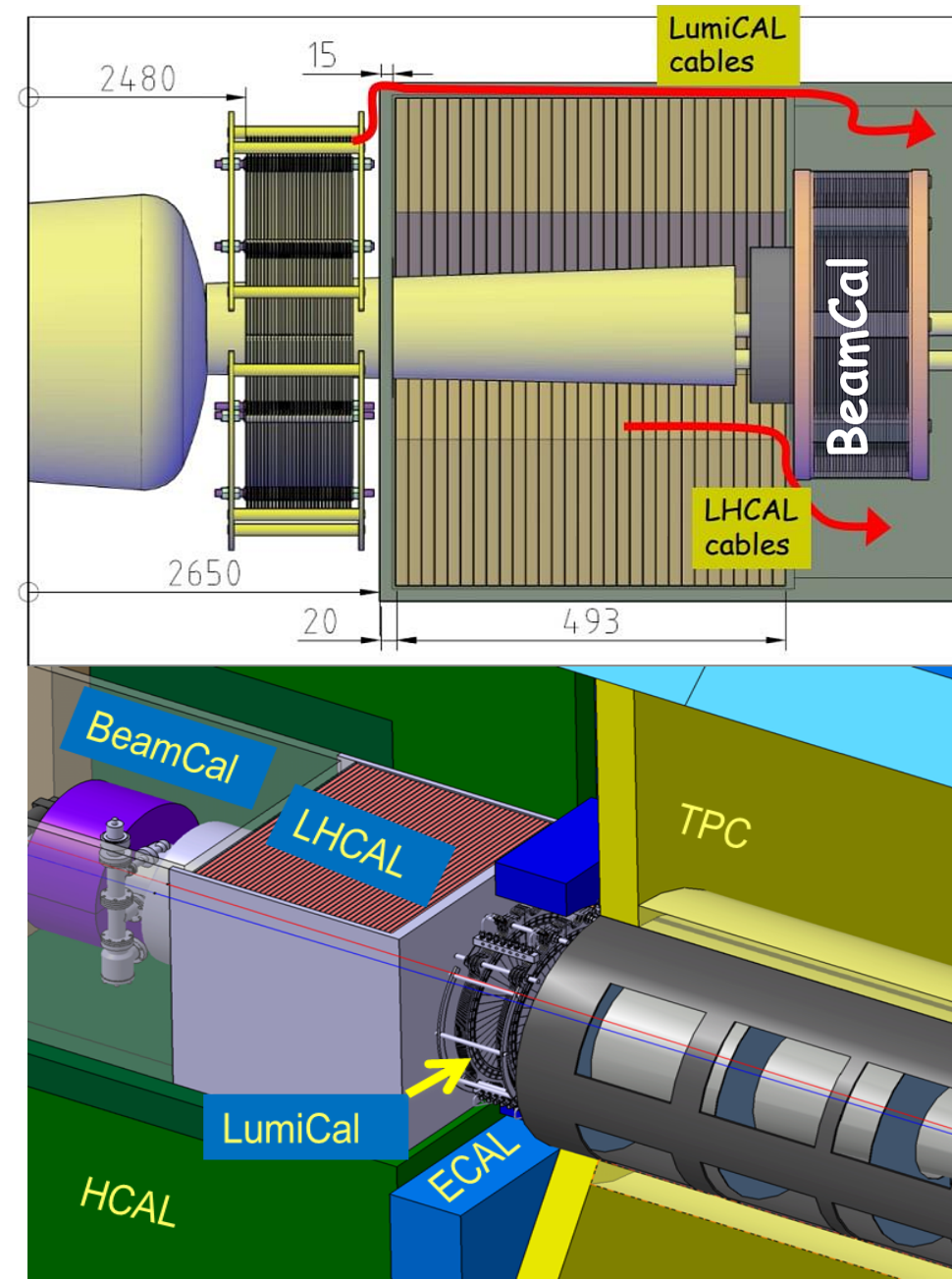

ILD forward region

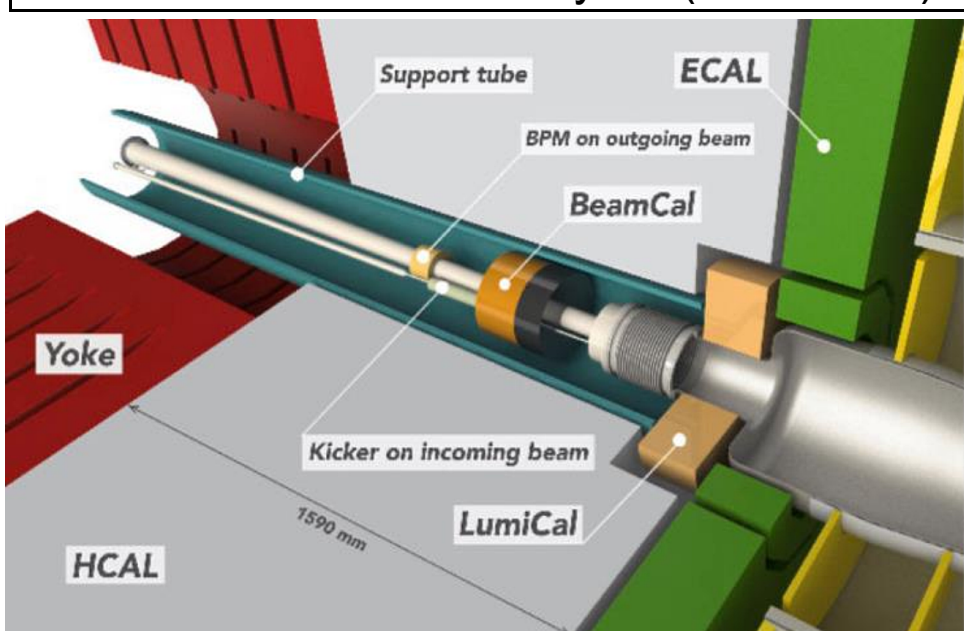

CLICdet forward region

LumiCal prototype

LumiCal - a Si-W electromagnetic sandwich calorimeter designed to measure the integrated luminosity with a precision better than 10^{-3} for ILC and 10^{-2} for CLIC

Si-sensor prototype (produced by Hamamatsu):

- 6-inch wafer;
- 320 μm thickness;
- 4 azimuthal sectors in one tile, each 7.5 degrees;
- radial segmentation – 64 pads, 1.8 mm pitch;
- 12 tiles makes full azimuthal coverage.

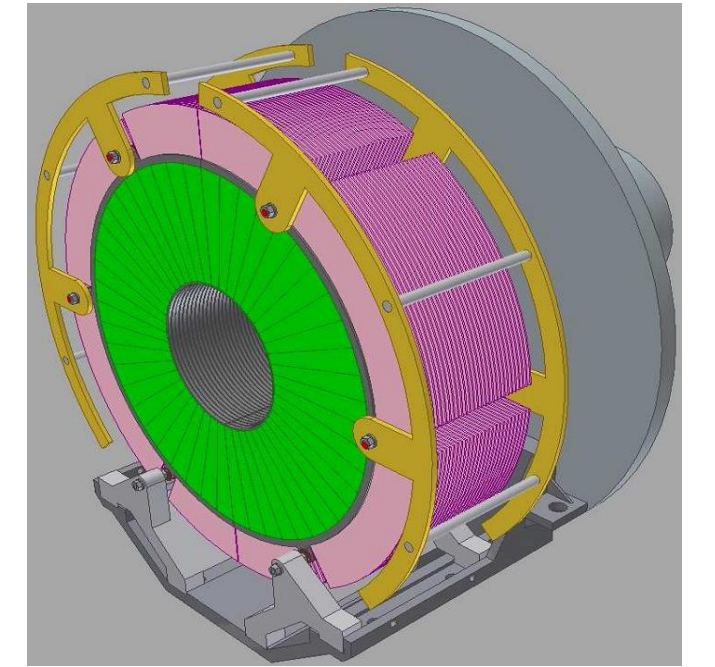

LumiCal

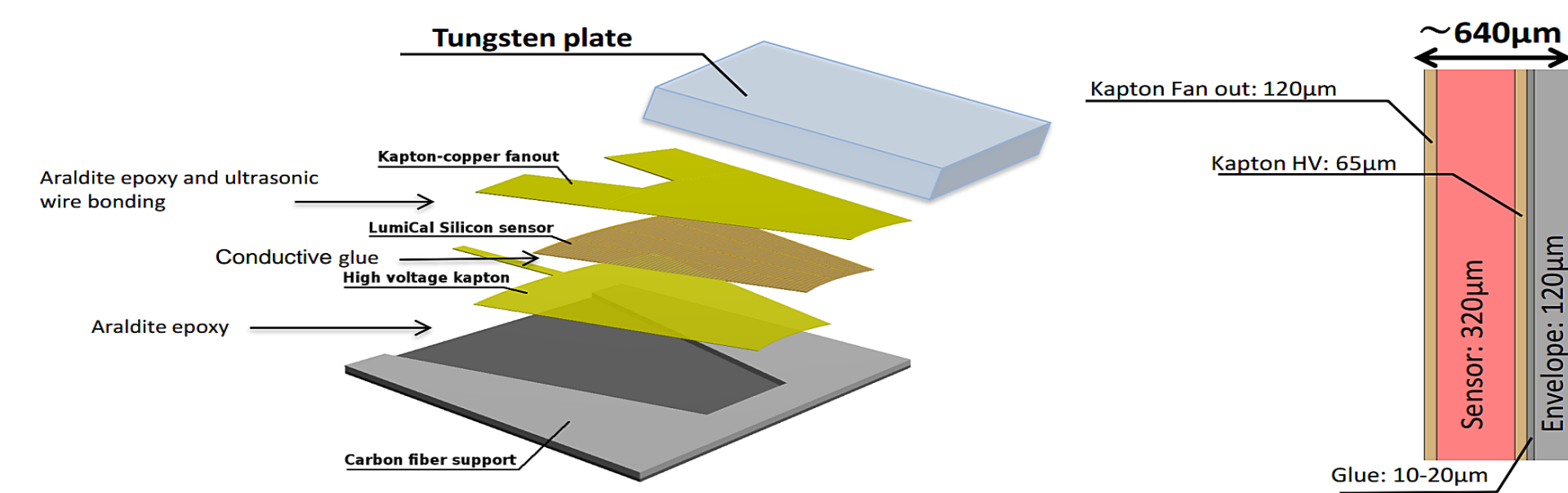

Thin LumiCal module

Test beam campaigns

- Several test-beam campaigns, 2014-2020
- Started with 4 fully equipped LumiCal planes with **APV25** readout
- Last campaign (2020) - 15 LumiCal planes, new **FLAME** readout tested.

Goals:

- Tests and demonstration of multi-plane operation of the forward detector prototype;
- Study of the electromagnetic shower in a precise and well known structure and compare with MC simulations;
- Measurement of Molière radius;
- Study of e-/ γ identification using bremsstrahlung;
- Energy and spatial resolution studies;
- Polar angle bias study

FLAME - FcaL Asic for Multiplane readout - a new complete readout electronic developed for LumiCal, integrating full on board functionality. 32 mix-mode channels (FE & 10bit ADC).

- Variable gain from 4fC (1 MIP) to 200pC (shower core).
- Sampling rate of up to 50MHz.
- Ultra low power (< 2mW/ch).
- Fast serializer & driver (up to 8 Gbps).
- 4 FLAME controlled by single FPGA.

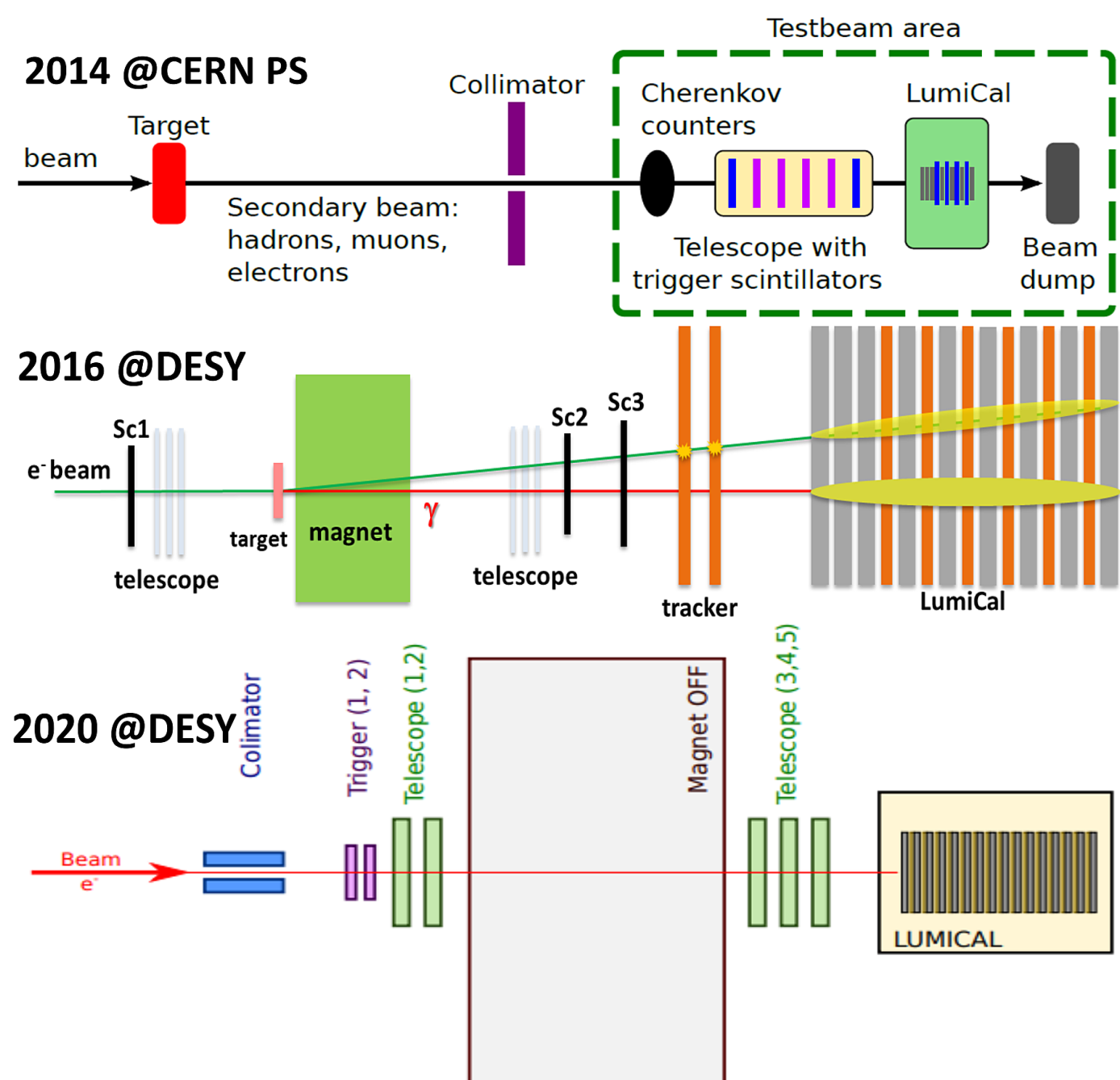

Results - transverse shower

- Shower parametrisation in radial direction: $F_E(r) = A_C e^{-\left(\frac{r}{R_C}\right)^2} + A_T \frac{2r^\alpha R_T^2}{(r^2 + R_T^2)^2}$

- The Molière radius, R_M , can be found from: $0.9 = \frac{\int_0^{2\pi} d\varphi \int_0^{R_M} F_E(r) r dr}{\int_0^{2\pi} d\varphi \int_0^{\infty} F_E(r) r dr}$

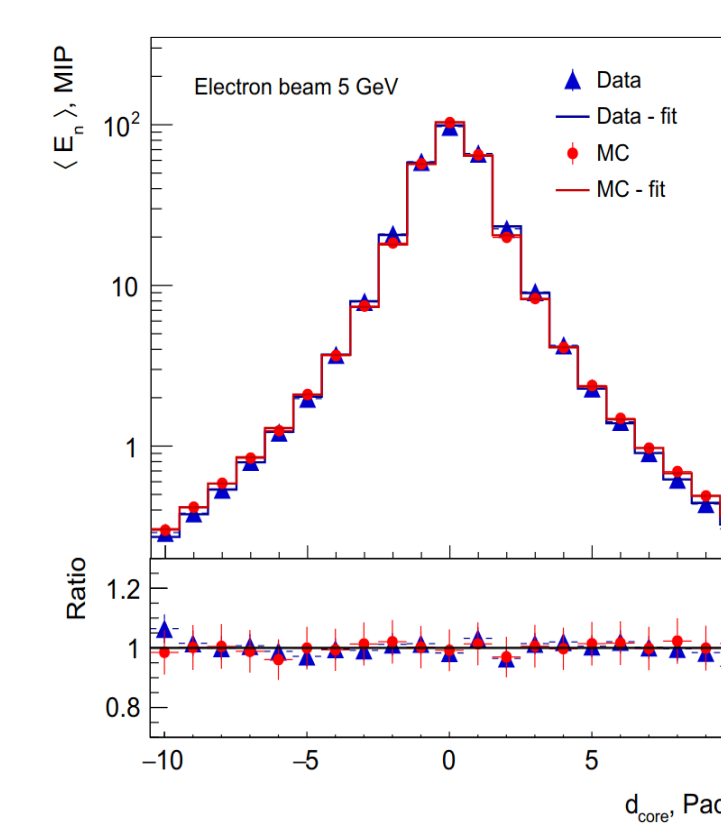

The transverse shower profile $\langle E_T \rangle$, as a function of d_{core} in units of pads.

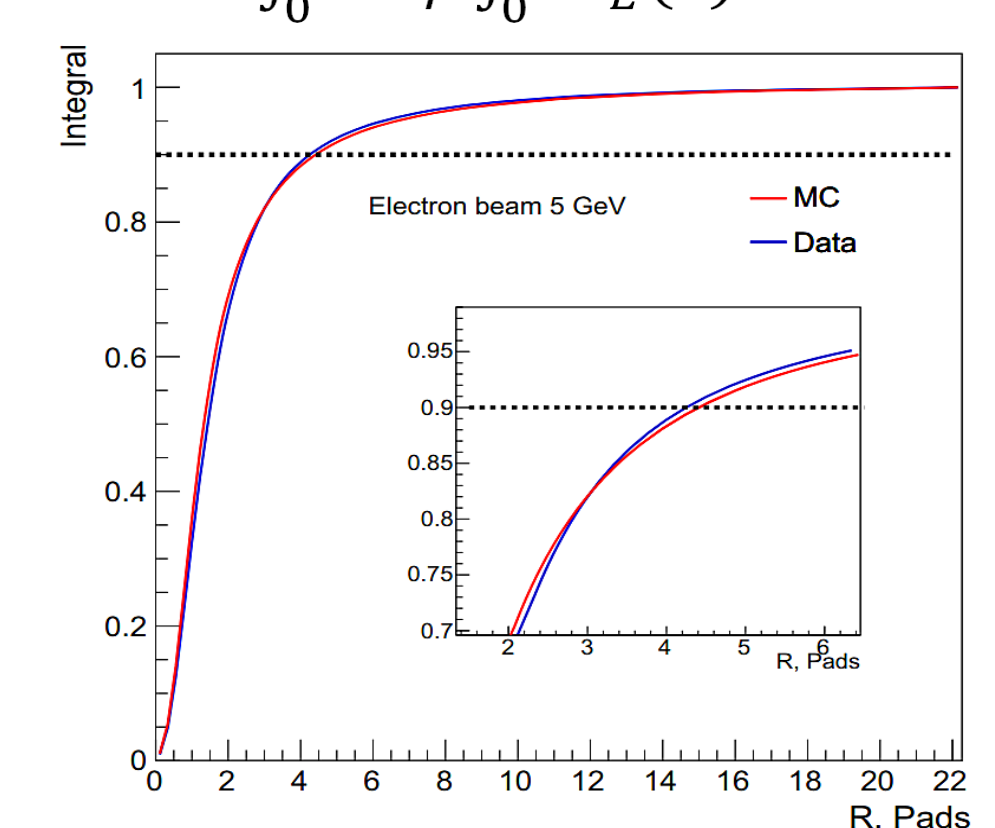

The integral on $F_E(r)$, extracted from the fit, as a function of the radius, R , in units of pads (1.8mm)

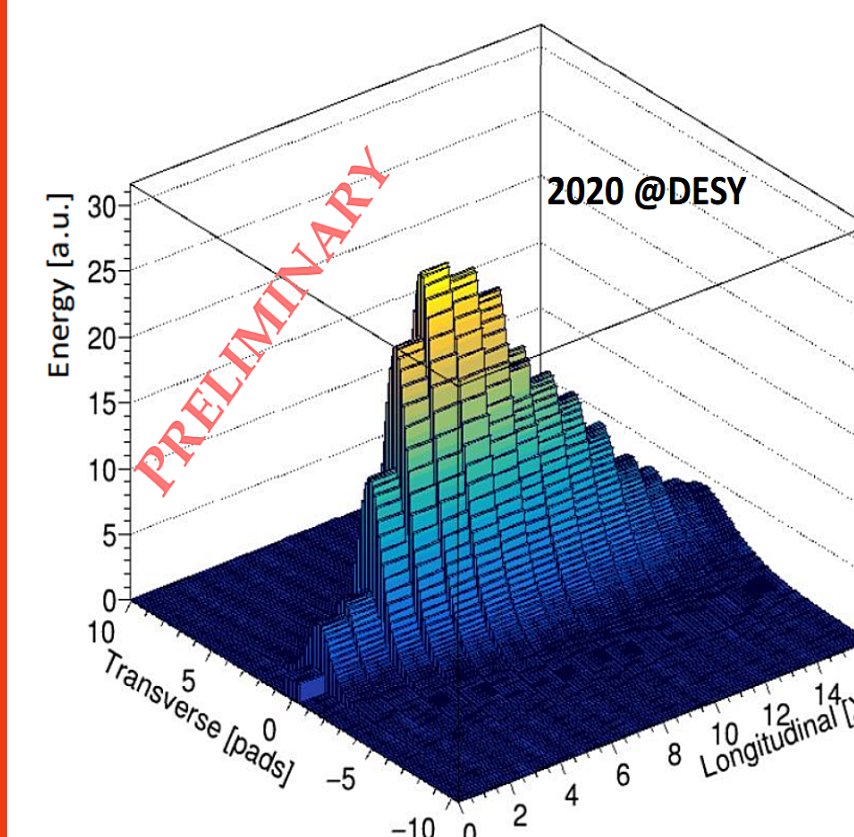

A lego plot of the transverse profile for each layer from the test-beam data

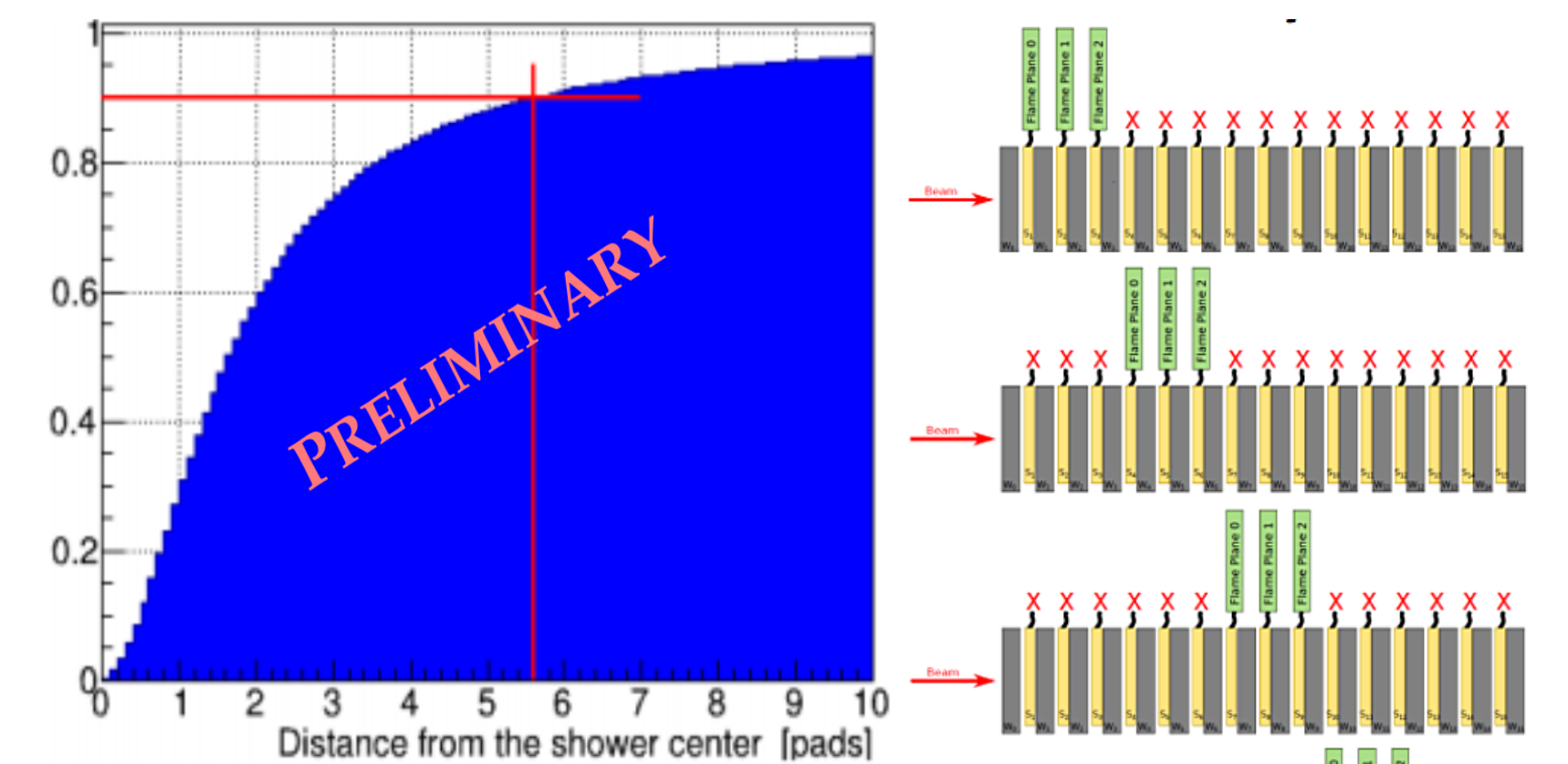

The integral on $F_E(r)$, that was extracted from the fit, as a function of the distance in units of pads (1.8mm) for 5 GeV e^- beam

The effective Molière radius has been estimated to be **10.1 mm (5.6 pads)**

Results - longitudinal shower

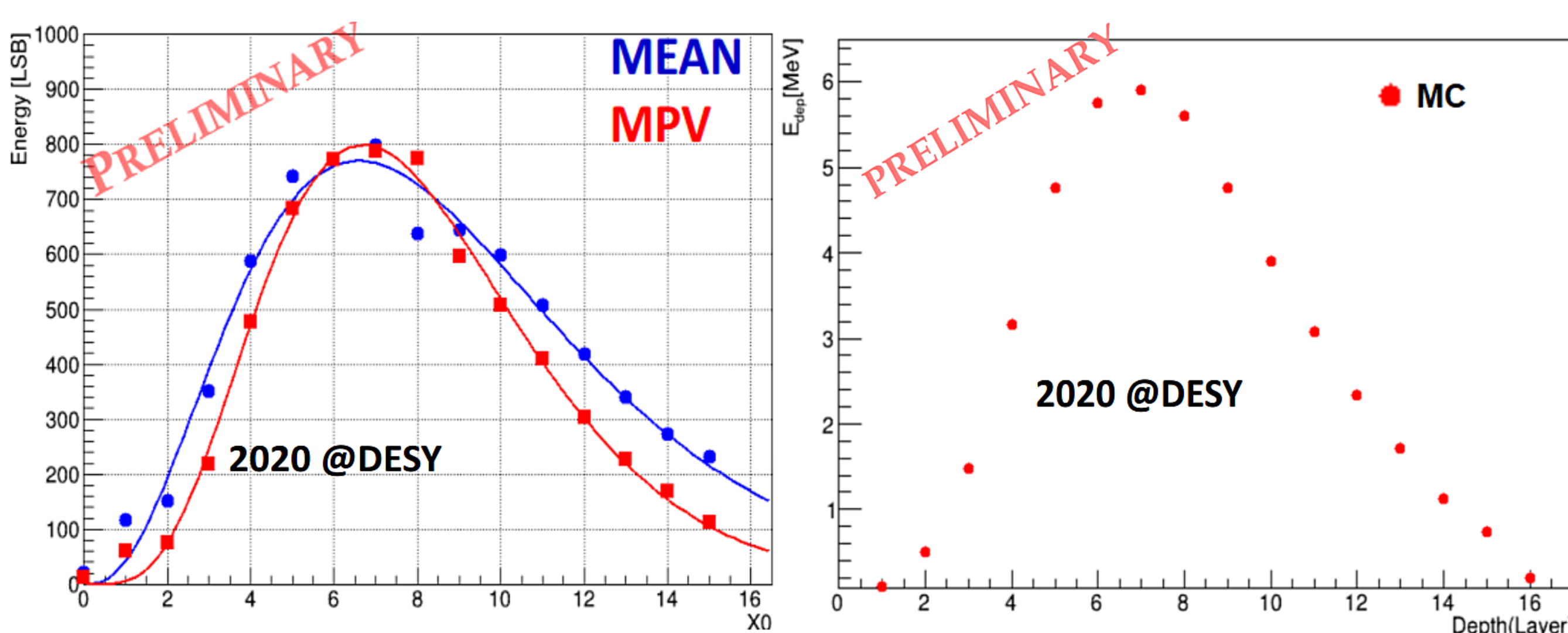

Conclusions and future steps

- Major components developed by FCAL Collaboration can be operated as a system in future LC experiments.
- The FCAL collaboration continues the detector R&D and forward region design optimisation.
- Thin LumiCal module with submillimeter thickness was developed and produced. Its geometry meets requirements of LumiCal conceptual design.
- Dedicated FLAME readout ASIC together with FPGA back-end were developed and tested in the beam for the first time.
- Results from the test of the compact calorimeter prototype are promising.
- Analysis of data and MC from the full compact calorimeter prototype test-beam is ongoing.
- Technologies developed in FCAL are applied in other experiments, e.g. CMS, XFEL and considered for LUXE at DESY.