

23rd Meeting of SRF Group in IDT/WG2

- ✓ Summary of crab cavity session at ILCX
- ✓ Summary of CM design session at ILCX
- ✓ Others (if any)

Attendees: A. Yamamoto, S. Michizono, K. Umemori, E. Cenni, S. Belomestnykh, S. Posen, M. Liepe, P. Burrows, S. Stapnes, P. McIntosh, L. Monaco, R. Geng, R. Rimmer, R. Ruber, T. Okugi, Kirk

<https://agenda.linearcollider.org/category/256/>

You can download every slide from this link

Kirk

Schedule of SRF (incl. crab cavity sub-) Group Meeting in IDT/WG2

Meeting #	Date	Contents
19	31/Aug	Preparation for ILC advisory panel, SRF session at ILCX2021
20	14/Sep	Progress of CM design, SRF session at ILCX2021
21	28/Sep	Agenda of SRF CM session at ILCX2021 fixed
22	12/Oct	Report of tuner exert meeting, Proposal for removal of 5K thermal shield
	14/Oct	Second meeting of ILC advisory panel of MEXT
	18/Oct	Third meeting of ILC advisory panel of MEXT
	26~29/Oct	ILC Workshop on Potential ILC Experiments (ILCX2021) remotely hosted by KEK at Tsukuba/Japan
23	09/Nov	Summary of SRF session at ILCX
24	23/Nov	
25	07/Dec	
26	21/Dec	

Questions/Discussions/Comments (memorandum) @23rd meeting

Translation by Kirk

- ILCX
 - Crab cavity
 - Q_L is same between pulsed and CW operation? → it's same
 - Dynamic aperture for extraction beamline was checked
 - Do we need expert meeting to discuss possibility of CW operation?
 - If we use CW mode, we need to check available cryogenic power and RF system at IP region
 - CM design
 - If we change something from TDR, we need to consider the impact on cost
 - For example, we added tuner access port, but we removed the 5K thermal shield. We need to estimate the cost is higher or lower after these changes.
 - Before real production, we will need some reviews on cavity/CM design by the other experts, not only WG2 members.

References (updated!)

- Proposal for ILC Pre-lab
 - <https://www.interactions.org/press-release/ilc-international-development-team-publishes-proposal-ilc>
- Technical Preparation and Work Packages
 - <http://doi.org/10.5281/zenodo.4742018>
- KEK homepage
 - <https://www2.kek.jp/ilc/en/>
- Technical Design Report
 - <https://ilchome.web.cern.ch/publications/ilc-technical-design-report>
 - <https://www2.kek.jp/ilc/en/docs/>
- The International Linear Collider Progress Report 2015
 - <https://www2.kek.jp/ilc/en/docs/>
- The International Linear Collider – A Global Project
 - Submitted to European Particle Physics Strategy Update, 2020.
 - <https://indico.cern.ch/event/765096/contributions/3295702/>
- ILC Action Plan
 - <https://www.kek.jp/ja/newsroom/2016/01/06/1400/>
 - <https://www.kek.jp/ja/newsroom/2018/04/24/1200/>
- Recommendations on ILC Project Implementation
 - https://www.kek.jp/ja/newsroom/attic/20191001_%20ILC%20Project.pdf

Backup slides including old slides

CM design session (still under arrangement)

- ◆ Date: 28/Oct (Thu)
- ◆ Time zone: 21:30~23:30 @JST, 14:30~16:30 @CEST, 8:30~10:30 @EDT, 7:30~9:30 @CDT, 5:30~7:30 @PDT
- ◆ Chair: Kirk Yamamoto (KEK)
- ◆ Agenda:
 - ◆ GDE & History (Akira Yamamoto, Kirk) [15 min]
 - ◆ Renewed CM design (Yuriy Orlov) [20 min]
 - ◆ Progress of tuner (Yuriy Pischalnikov) [20 min]
 - ◆ HPGS (Umemori-san) [15 min]
 - ◆ Ti-SS & Al-SS joint (Dohmae-san) [10 min]
 - ◆ Pipe standard used for CM and CAD software (Konomi-san) [5 min]
 - ◆ RF distribution (Matsumoto-san) [10 min]
 - ◆ Progress of auto cleaning system (Stephane Berry) [15 min]
 - ◆ Discussion (Everyone) [? min]

Items to be discussed in CM design session

- ◆ 5K thermal shield (removal of lower part)
 - ◆ Asking Tom Peterson
- ◆ Magnetic shield (installed inside helium tank)
- ◆ Ti-SS joint for 2-phase pipe including pre-cooling line
- ◆ SS-Al joint for Al thermal straps of splittable QUAD
- ◆ Port of current-lead for QUAD
- ◆ Position of HOM absorber
- ◆ Availability in 45ft container
- ◆ RF distribution (how to equip with CM)
- ◆ Tuner design
- ◆ Access port to tuner

Cavity package and tuner design

Akira Yamamoto-san can comment about
if we change the length of cavity and CM, what happens

XFEL TESLA-Cavity

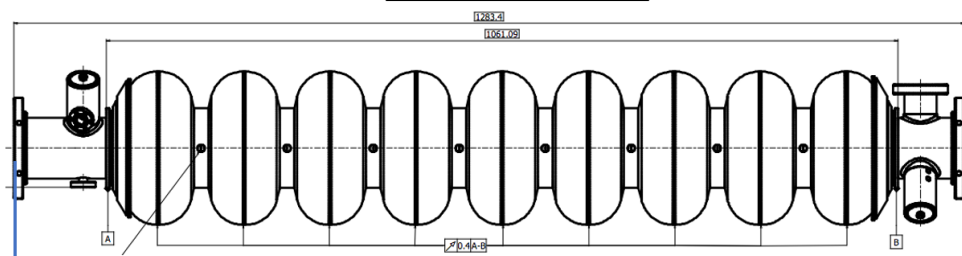

ILC-Cavity

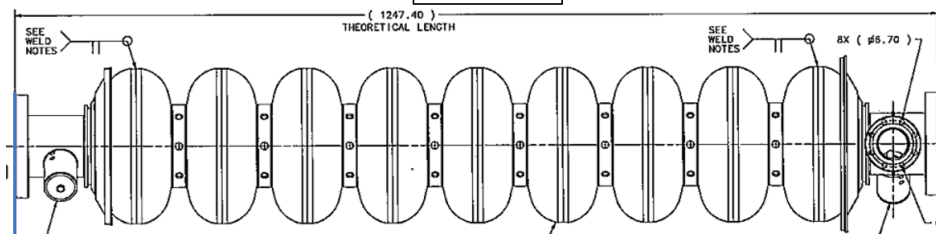

36mm

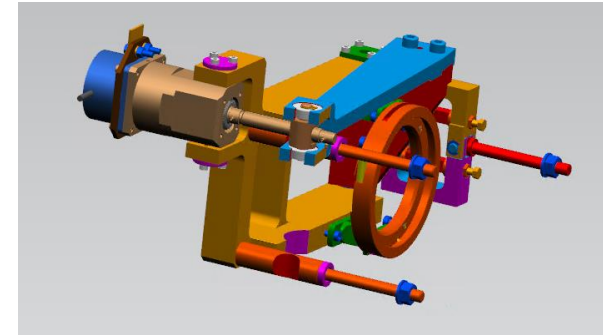

E-XFEL

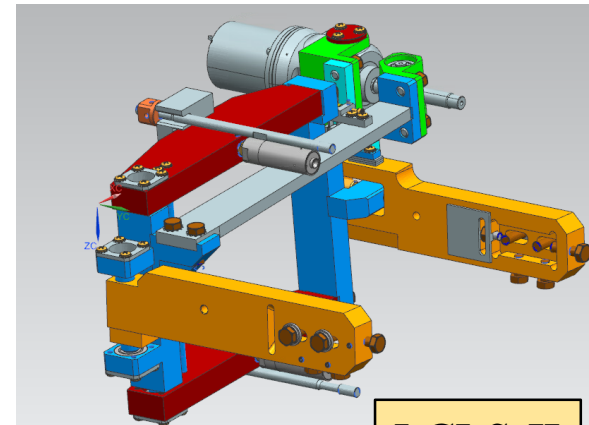

LCLS-II

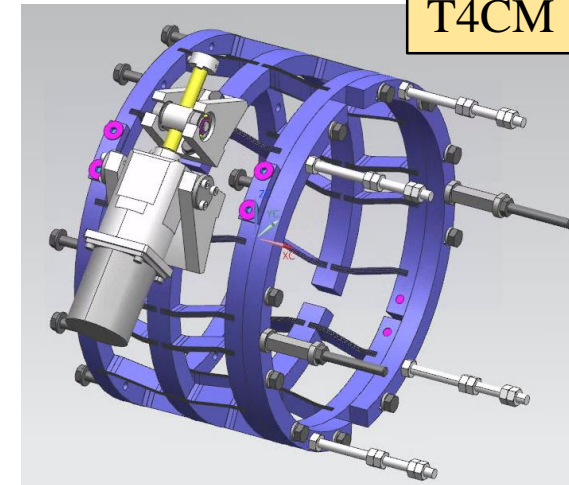

T4CM

Dimension check for cavity and CM

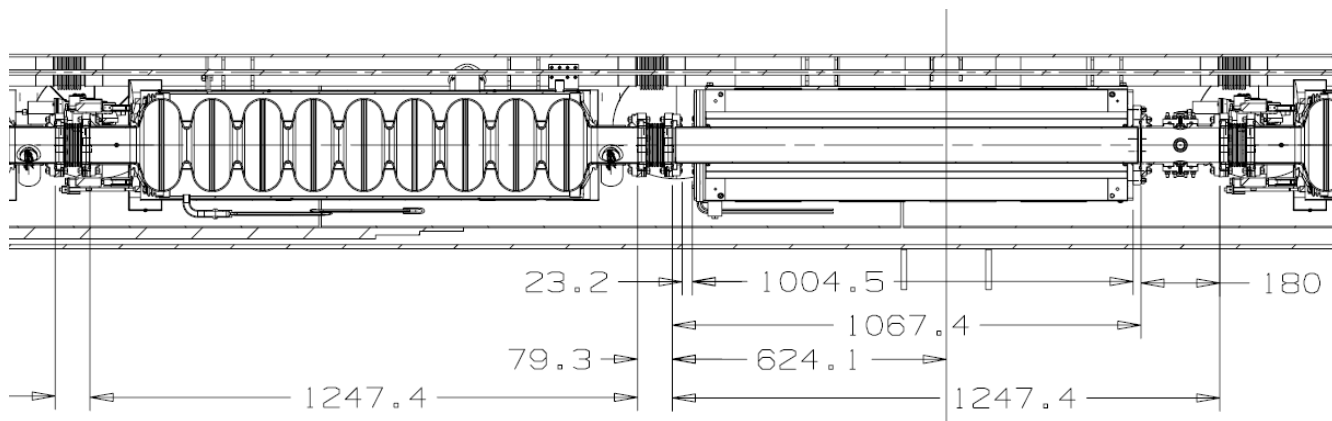

Table 3.5
Cavity parameters for the SCRF cavities.

Parameter	Value
Type of accelerating structure	Standing wave
Accelerating mode	TM_{010}, π mode
Type of cavity-cell shape	Tesla (or Tesla-like)
Fundamental frequency	1.300 GHz
Operation:	
- Average gradient (range allowed)	31.5 MV/m ($\pm 20\%$)
- Quality factor (at 31.5 MV/m)	$\geq 1 \times 10^{10}$
Qualification:	
- Average gradient (range allowed)	35.0 MV/m ($\pm 20\%$)
- Quality factor (at 35 MV/m)	$\geq 0.8 \times 10^{10}$
- Acceptable radiation (at 35 MV/m)	$\leq 10^{-2} \text{ mGy/min}^\dagger$
Active length	1038.5 mm
Total length (beam flanges, face-to-face)	1247.4 mm
Input-coupler pitch distance, including inter-connection	1326.7 mm
Number of cells	9
Cell-to-cell coupling	1.87%
Iris aperture diameter (inner/end cell)	70/78 mm
Flange inner diameter	210 mm

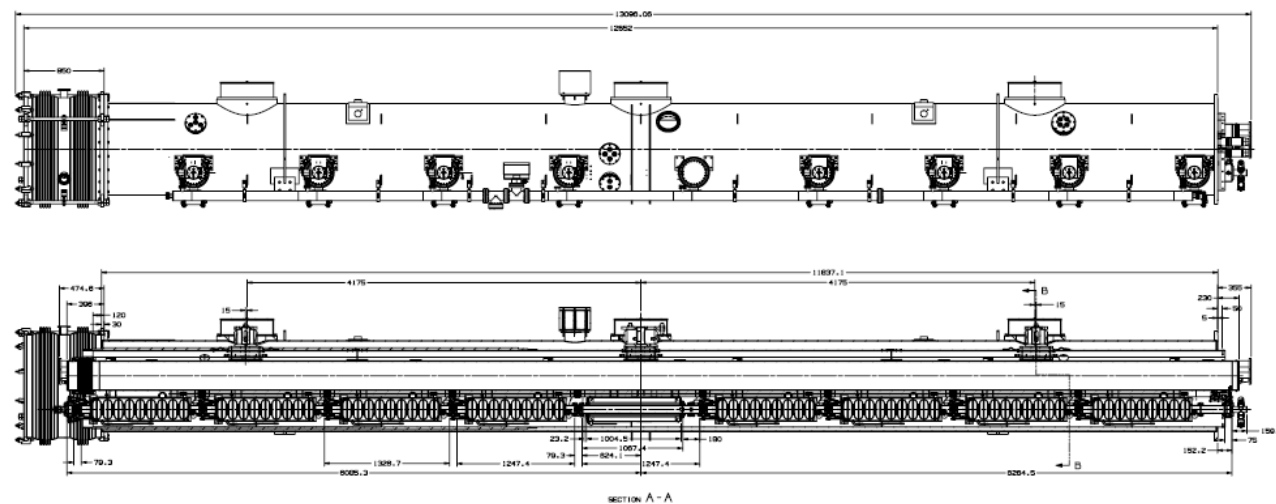
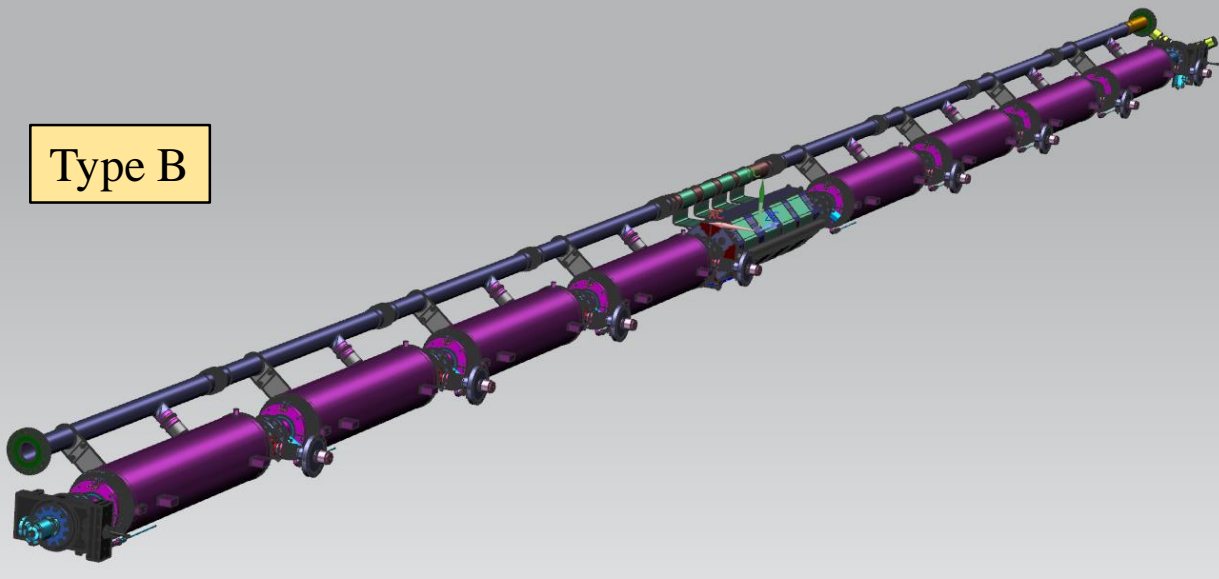

Table 3.1
Summary of key numbers for the SCRF Main Linacs for 500 GeV centre-of-mass-energy operation. Where parameters for positron and electron linacs differ, the electron parameters are given in parenthesis.

<i>Cavity (nine-cell TESLA elliptical shape)</i>			
Average accelerating gradient	31.5	MV/m	(m)
Quality factor Q_0	10^{10}		
Effective length	1.038	m	
R/Q	1036	Ω	
Accepted operational gradient spread	$\pm 20\%$		
<i>Cryomodule</i>			
Total slot length	12.652	m	
Type A	9 cavities		
Type B	8 cavities	1 SC quad package	
<i>ML unit (half FODO cell)</i>			
(Type A - Type B - Type A)	282 (285)	units	
<i>Total component counts</i>			
Cryomodule Type A	564 (570)		
Cryomodule Type B	282 (285)		
Nine-cell cavities	7332 (7410)		
SC quadrupole package	282 (285)		
Total linac length – flat top.	11027 (11141)	m	
Total linac length – mountain top.	11072 (11188)	m	
Effective average accelerating gradient	21.3	MV/m	
<i>RF requirements (for average gradient)</i>			
Beam current	5.8	mA	
beam (peak) power per cavity	190	kW	
Matched loaded Q (Q_L)	5.4×10^6		
Cavity fill time	924	μs	
Beam pulse length	727	μs	
Total RF pulse length	1650	μs	
RF-beam power efficiency	44%		

Drawing for Type A and Type B

Type B



I already requested Yuriy to develop drawing of Type A CM

Table 3.1

Summary of key numbers for the SCRF Main Linacs for 500 GeV centre-of-mass-energy operation. Where parameters for positron and electron linacs differ, the electron parameters are given in parenthesis.

<i>Cavity (nine-cell TESLA elliptical shape)</i>		
Average accelerating gradient	31.5	MV/m
Quality factor Q_0	10^{10}	
Effective length	1.038	m
R/Q	1036	Ω
Accepted operational gradient spread	$\pm 20\%$	
<i>Cryomodule</i>		
Total slot length	12.652	m
Type A	9 cavities	
Type B	8 cavities	1 SC quad package
<i>ML unit (half FODO cell) (Type A - Type B - Type A)</i>		
	282 (285)	units
<i>Total component counts</i>		
Cryomodule Type A	564 (570)	
Cryomodule Type B	282 (285)	
Nine-cell cavities	7332 (7410)	
SC quadrupole package	282 (285)	
Total linac length – flat top.	11027 (11141)	m
Total linac length – mountain top.	11072 (11188)	m
Effective average accelerating gradient	21.3	MV/m
<i>RF requirements (for average gradient)</i>		
Beam current	5.8	mA
beam (peak) power per cavity	190	kW
Matched loaded $Q (Q_L)$	5.4×10^6	
Cavity fill time	924	μs
Beam pulse length	727	μs
Total RF pulse length	1650	μs
RF-beam power efficiency	44%	

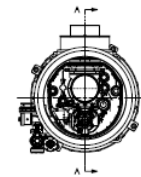
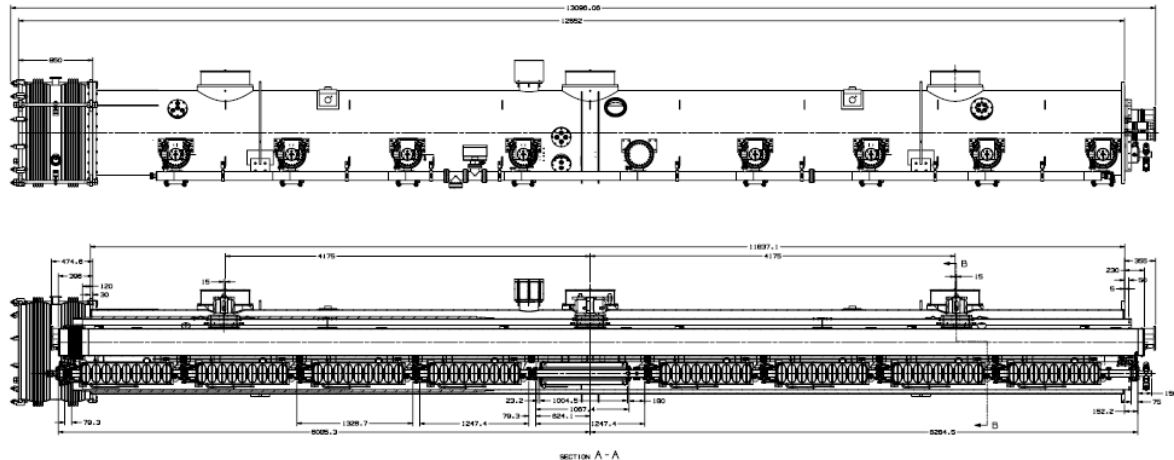

T4CM and renewed ILC CM

Figure 3.15
Representative cryo-
module cross section

T4CM

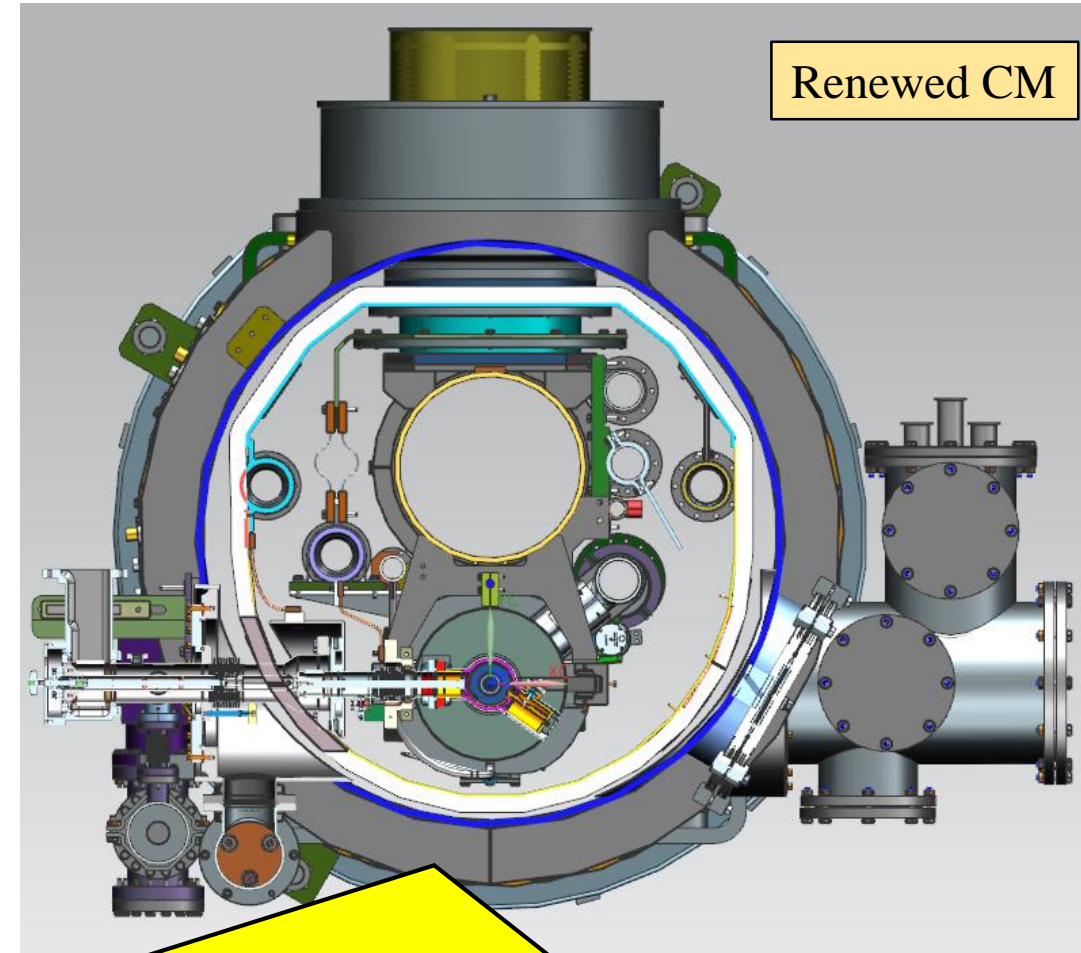
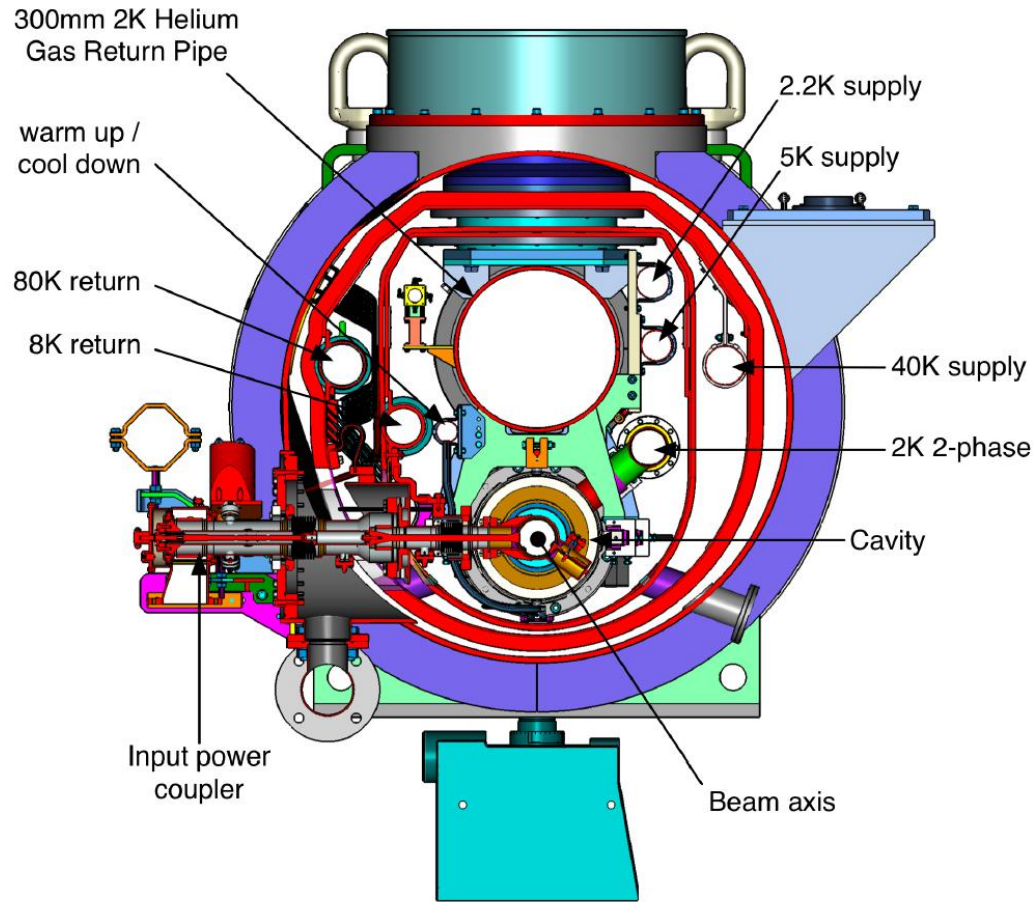

Tom Peterson can comment about the impact on the removal of 5K thermal shield (lower part)

Progress of tuner

Dynamic Test (simulated LFD compensation)



- ◆ Yuriy demonstrated the imitated LFD compensation by piezo at room temperature

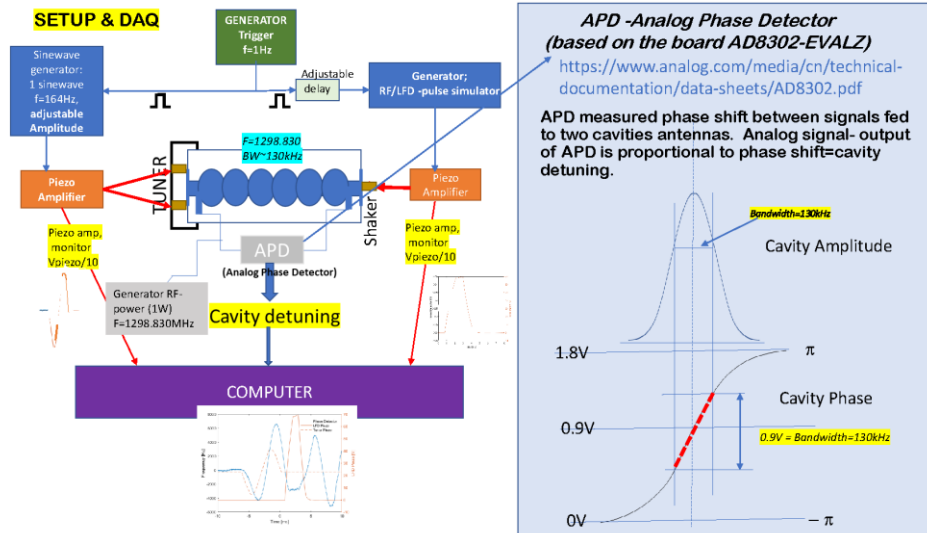

COMPENSATION OF LFD WITH PIEZO-TUNER Piezo-tuner compensated LFD from 1400Hz to 140Hz (10 times)

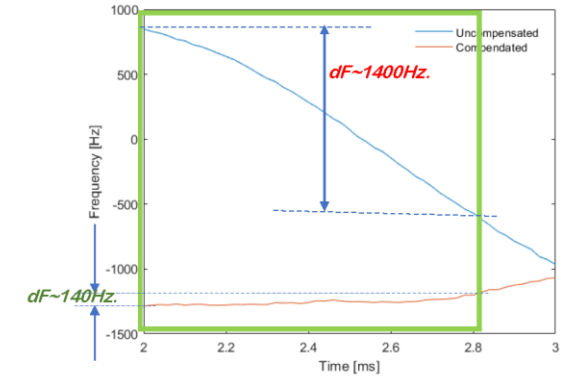
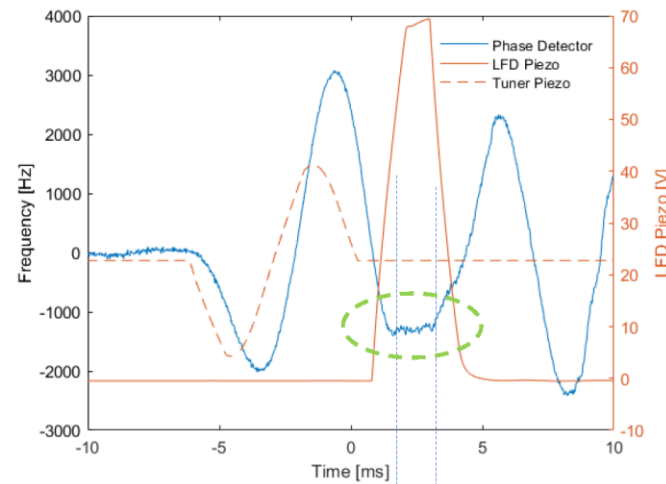

1400Hz vs 140Hz (10 vs 1)

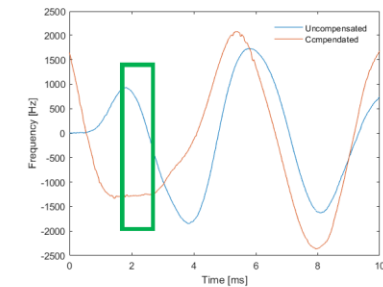

Progress of HPGS in KEK

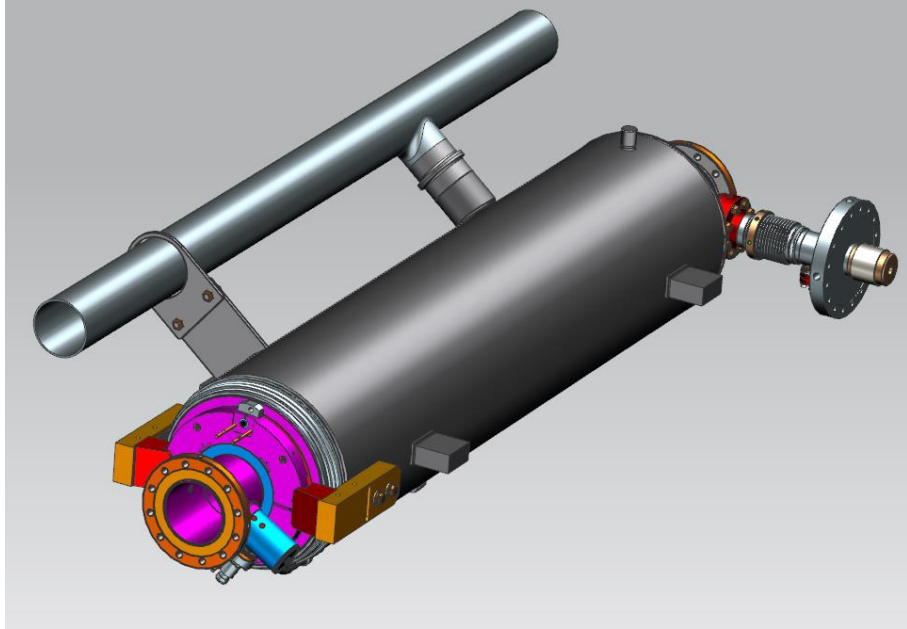

- ◆ Discussion with cryogenics group
- ◆ Negotiation with the local government
- ◆ Refrigeration safety regulation is preferable for ILC
- ◆ KEK will visit to KHK as authority of HPGS soon

Joint between different metals

Explosive bonding by ASAHI Chemical is available for these two types of joints

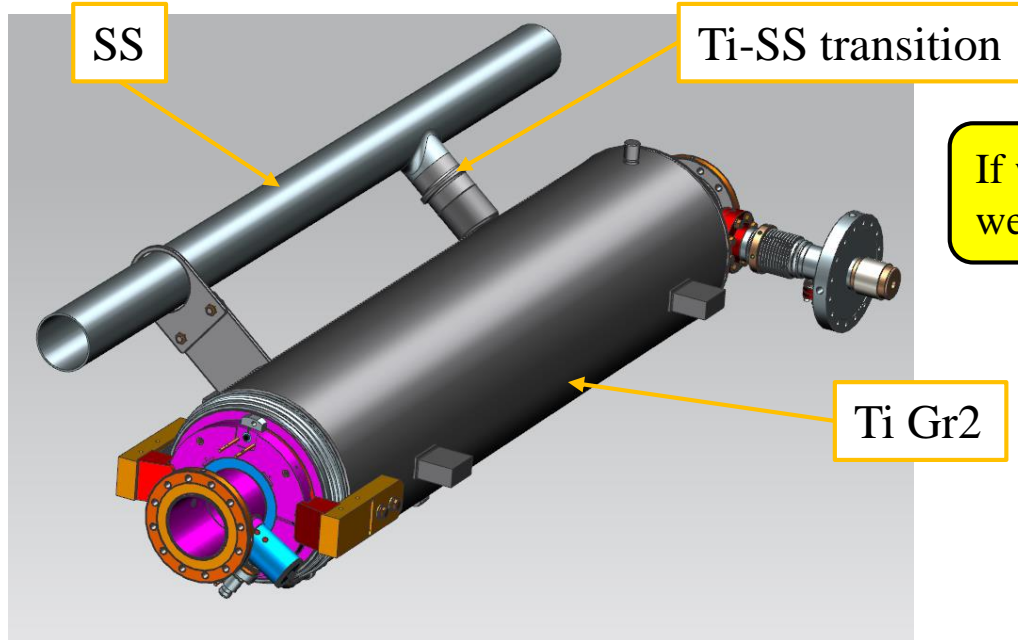

If we use Aluminum cooling pipe, we need the joint between Al and SS here

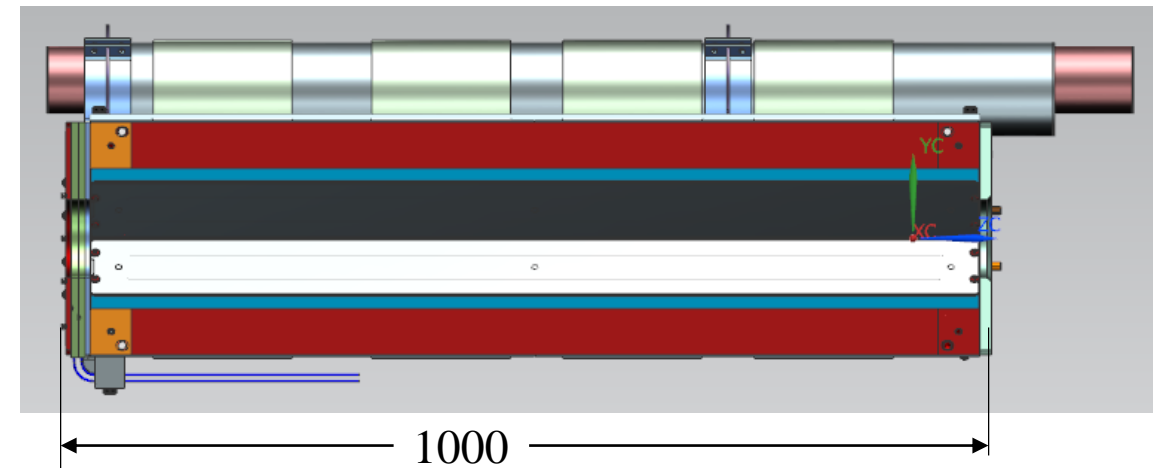
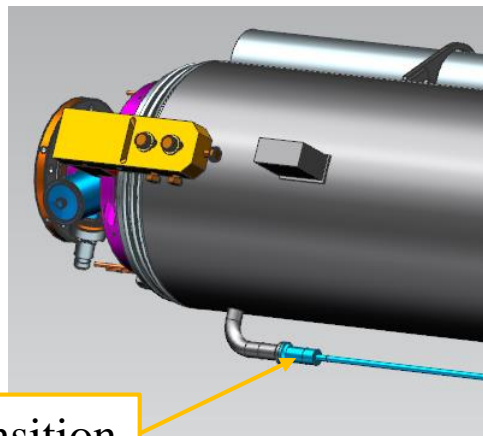
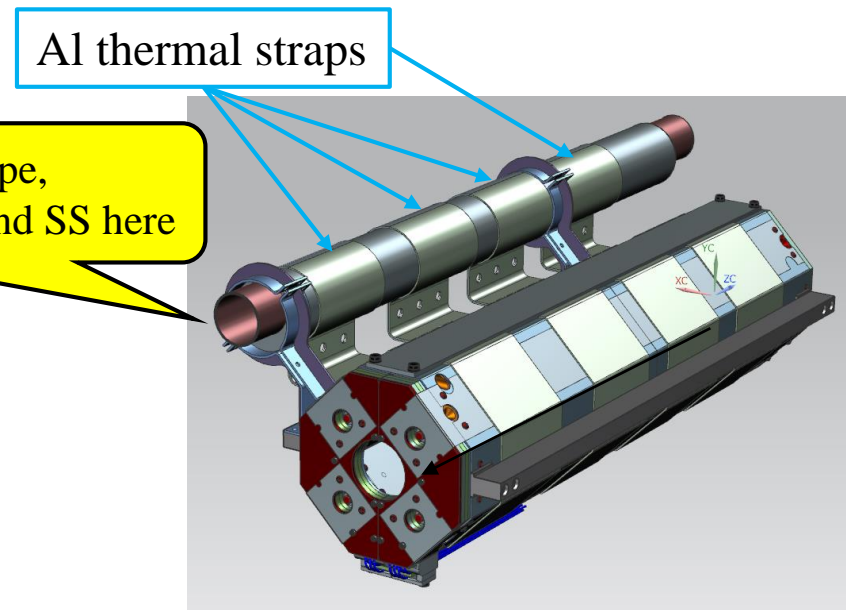

Standard of cooling pipes

Y. Orlov							By Tom P. Calculation By Ouchi-san		ASME/ANSI selection	JIS selection
Cryogenic Line	OD, mm	ID,mm	Wall. mm	Material		ID,mm	OD/ID/t	OD/ID/t	OD/ID/t	
2.2K Subcooled supply	A	63.500	60.198	1.651	316L St. Steel	Tube, 2.5"-OD, .065" Wall, 316L SS	60.2	63.5/60.2/1.65	ASME SA249 63.5/60.2/1.65	JIS G3447 63.5/59.5/2
Gas helium return header, structural support	B	312.000	300.000	6.000	316L St. Steel	Tube, 300mm-OD, 6mm Wall, 316L SS	300.0	312/300/6	312/300/6	312/300/6
Not used	C	63.500	57.404	3.048	316L St. Steel	Tube, 2.5"-OD, .120" Wall, 316L SS				
5K shield and intercept supply	C	60.325	57.023	1.651	316L St. Steel	Pipe 2", SCH 5S	56.1	60.33/56.11/2.11	ASME B36.10 60.3/57/1.65	JIS G3459 60.5/57.2/1.65
8K shield and intercept return	D	88.900	76.200	6.350	Al 6061	Tube, 3.5"-OD. .25" Wall, Al 6061	69.9	82.55/69.85/6.35	ASTM B241 88.9/76.2/6.35	JIS H4080 90/78/6
High temperature shield and intercept supply	E	76.200	71.984	2.108	316L St. Steel	Tube, 3"-OD, .083" Wall, 316L SS	72.0	76.2/71.98/2.11	ASME SA249 76.2/72/2.1	JIS G3459 76.3/72.1/2.1
High temperature shield and intercept return	F	88.900	76.200	6.350	Al 6061	Extrusion	79.4	92.08/79.38/6.35	ASTM B241 88.9/76.2/6.35	JIS H4080 90/78/6
2-Phase pipe	G, 2-phase	73.025	68.809	2.108	316L St. Steel	Pipe 2 1/2", SCH 5S	69.0	76.1/72.1/2	ASME B36.10 73.0/68.78/2.11	JIS G3459 76.3/72.1/2.1
	"Chimney" -SS	60.325	57.023	1.651	316L St. Steel	Pipe 2", SCH 5S	54.9	60.33/56.11/2.11	ASME B36.10 60.3/57/1.65	JIS G3459 60.5/57.2/1.65
	"Chimney" -Ti	60.325	57.023	1.651	Ti	Pipe 2", SCH 5S		60.33/56.11/2.11	ASME B36.10 60.3/57/1.65	JIS G3459 60.5/57.2/1.65
Warm-up/cool-down line	H	42.164	37.948	1.651	316L St. Steel	Pipe 1 1/4", SCH 5S	38.9	42.16/38.86/1.65	ASTM A312 42.16/38.9/1.65	JIS G3459 42.7/39.4/1.65

RF distribution system equipped with CM

Figure 3.42
The DKS arrangement in the main-linac tunnel for the mountainous topography. One DKS unit (39 cavities) is shown.

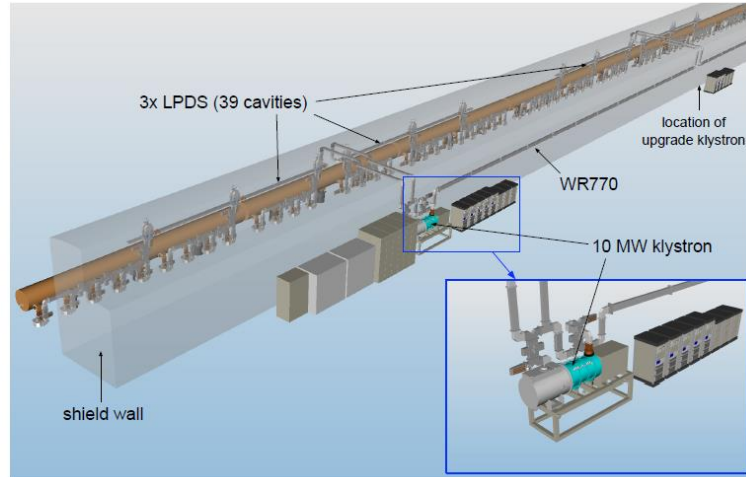

Matsumoto-san has an idea to equip the waveguide system with CM

Figure 3.40
Cross section of the main-linac tunnel cross section for the mountainous topography site-dependent design.

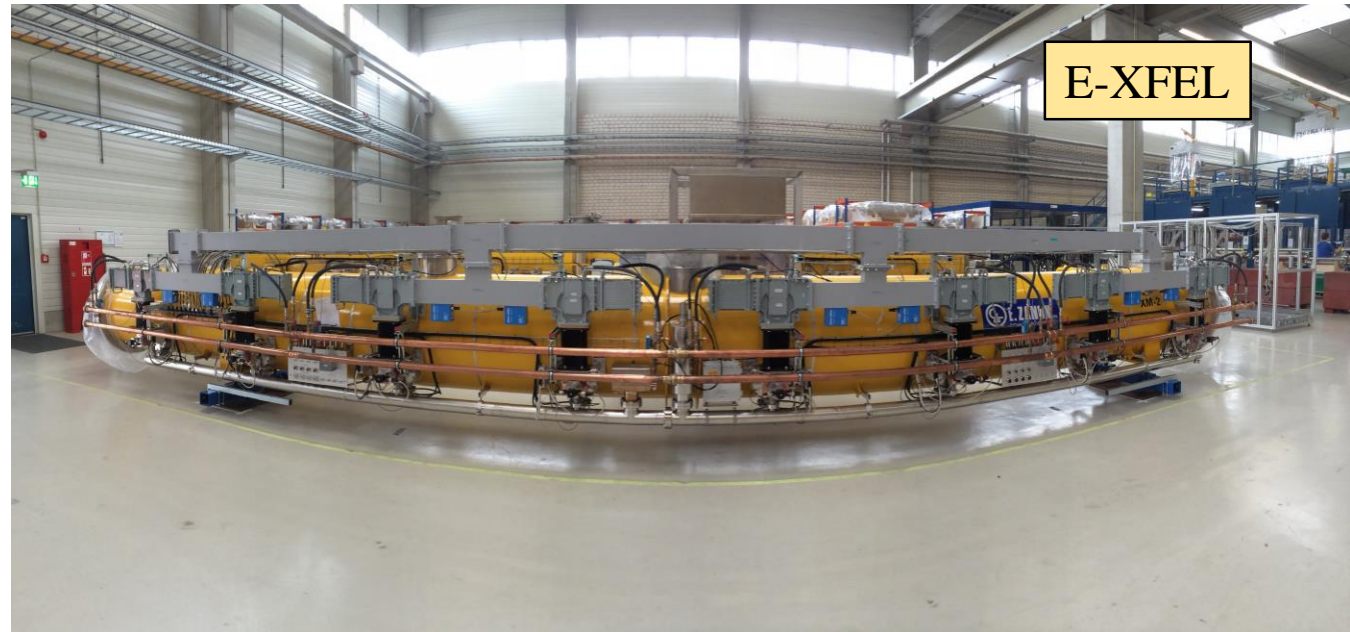
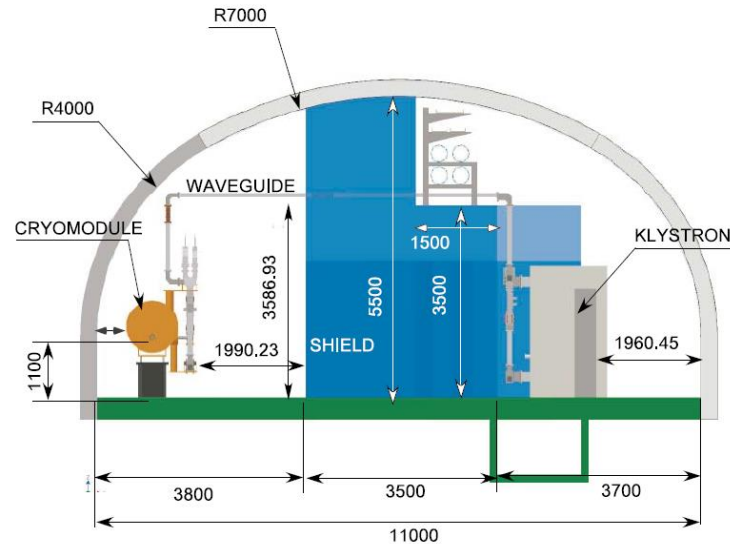

Progress of auto cleaning system

Stephane will summarize the worldwide progress of auto cleaning system

ceatech  **Framework of the project**

The project consists in providing a cleaning solution for cavity flanges in cleanroom ISO4 for workstations COUPLER and STRING

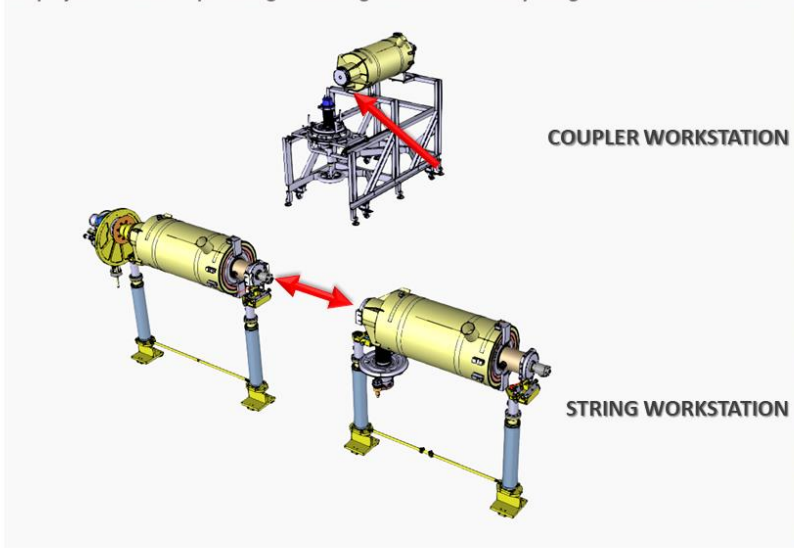

COUPLER WORKSTATION

STRING WORKSTATION



Commissariat à l'énergie atomique et. aux énergies alternatives Stéphane BERRY 25 octobre 2020 3



Preparation for ILC advisory panel of MEXT

Including items:

- Overview
- SRF WPs
- SRF Infrastructure
- Domestic efforts
- Worldwide efforts

Achievement of ILC technology and future plan (a) Basic Draft

Since the publication of the Technical Design Report (TDR) in 2013, the key technical developments have progressed and >90% of the technologies required for construction have been established.

Technology achievement	60%	70%	80%	90%	100%	tasks
SRF cavity		~2018 Technology development → Model work → Prototype		2018~2021 High performance and cost reduction of cavities	2021	International shared mass production demonstration (Confirmation of performance achievement)
Cryomodule (CM)		(construction and operation of the EuXFEL, the role of the accelerator prototype)				(International transfer demonstration)
e- source		~2018 Tech. Design → Tech. Development → Model → Tech. Demonstration				confirmation
e+ source Undulator scheme		~2018 Tech. Design → Tech. Development → Model		2018~2021 Tech. Demonstration		Target, magnetic focusing
e+ source e-driven scheme		~2018 Tech. Design → Tech. Development → Model		2018~2021 Tech. Demonstration		Target, capture cavity
DR		~2018 Tech. Design → Tech. Development → Model → Tech. demonstration achieved at KEK ATF				Kicker
Final focus		~2018 Tech. Design → Tech. Development → Model → Tech. demonstration achieved at KEK ATF				Stable operation
Dump		~2018 Tech. Design → Tech. Development → Model		2018~2021 Facility design		Remote handling

: ~2018
 : 2018~2021
 : 2022~

Model work: small-scale models, partial/component models.
Prototype: demonstration at the full scale.
Demonstrator: Technology transfer (to industry) for manufacturing of actual equipment.

5

How accurate are these percentages?

Slide example for SRF overview

Progress in SRF (b) Response Draft

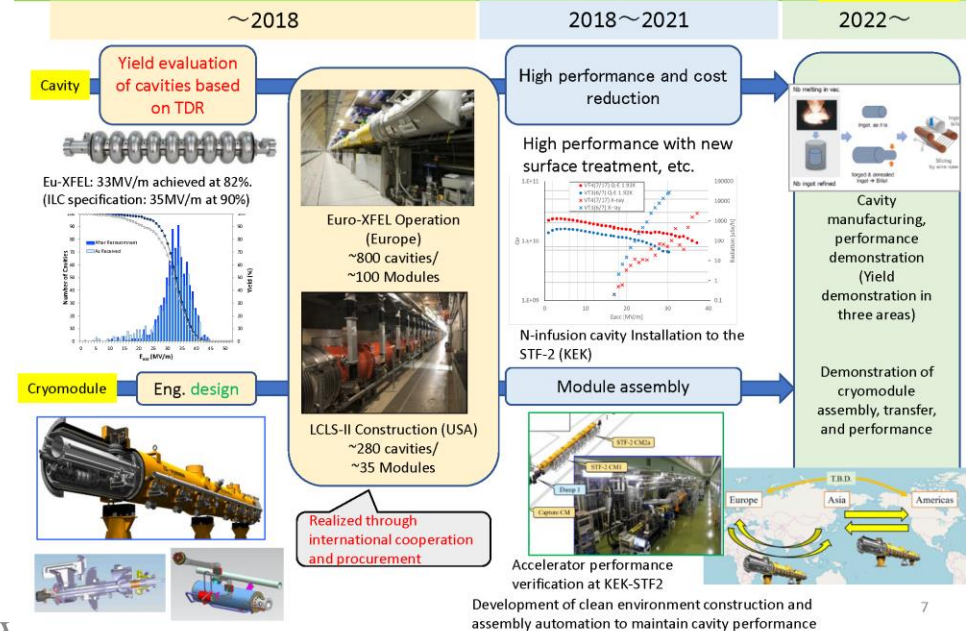

7

We would like the Japanese side to handle the final preparation of these documents.
 If necessary, we will request you all individually.
 We already requested some WG2 members and ad-hoc members to prepare for slides.

ILC Cryomodule Design:

History and Advances

A. Yamamoto

- ILC CM design, **Type 4**, established, for the TDR baseline during the GDE phase, in 2010 – 2011, **based on Eu-XFEL CM design**
 - It was updated from XFEL design to adapt to “**ILC short-short cavity**”, and **longer SCQ** packages, with global effort and consensus with GDE, mainly in cooperation between Fermilab and KEK, with keeping communication with EU members.
 - It has been stored at **EDMS’ of Fermilab and DESY (and at KEK), but with old CAD version**
- We are intending to **resume the Type-4 design** as our starting point for the ILC-IDT to prepare for ILC Pre-Lab,
 - Unfortunately, the **CAD system** has been **updated at Fermilab and KEK**, and it is not so convenient for quick re-starting.
- It has been **proposed** by Fermilab, to use the **LCLS-II CM CAD drawing** for **resuming the Type-4 CM design** drawing by using the current CAD system, NX, as a quickest and practical approach.
- The **Type-4 CM design, resumed by using NX**, will become the **new starting point to be globally discussed** again, how we may update it to be the best appropriate design for the ILC CM, used in the ILC PreLab WP1 and WP2.

Starting point of CM drawing for ILC

There were some meetings between KEK and FNAL/SLAC to discuss CM drawing including tuner system

- ◆ Drawing developed in the GDE era is old
- ◆ We'd like to start with the CM drawing for LCLS-II
 - ◆ Still tentative conclusion for JP/US
 - ◆ Discussion with colleagues in EU is planned
- ◆ This plan is under progress between Japan and US
- ◆ Probably, the CAD software will be common in future
 - ◆ NX is used in FNAL/DESY (from Omet-san)
 - ◆ INVENTOR/AUTOCAD (AUTODESK) are used in KEK
 - ◆ Creo (PTC) is used by Ohuchi-san

A. Yamamoto, Konomi-san, Kirk
S. Belomestnykh, Y. Orlov, T. Peterson

History of CM drawing for ILC (my knowledge)

- ◆ During the GDE era, CM design was developed among Japan, US and EU
- ◆ In TDR, **Type-IV CM** design was presented as follows
- ◆ In my understanding, **Type-IV CM drawing is stored in EDMS at DESY**
 - ◆ In Japan and US, nobody has this drawing, but KEK has the close drawing (not exactly the same!)
- ◆ Unfortunately, nobody took over this drawing after TDR in Japan and US

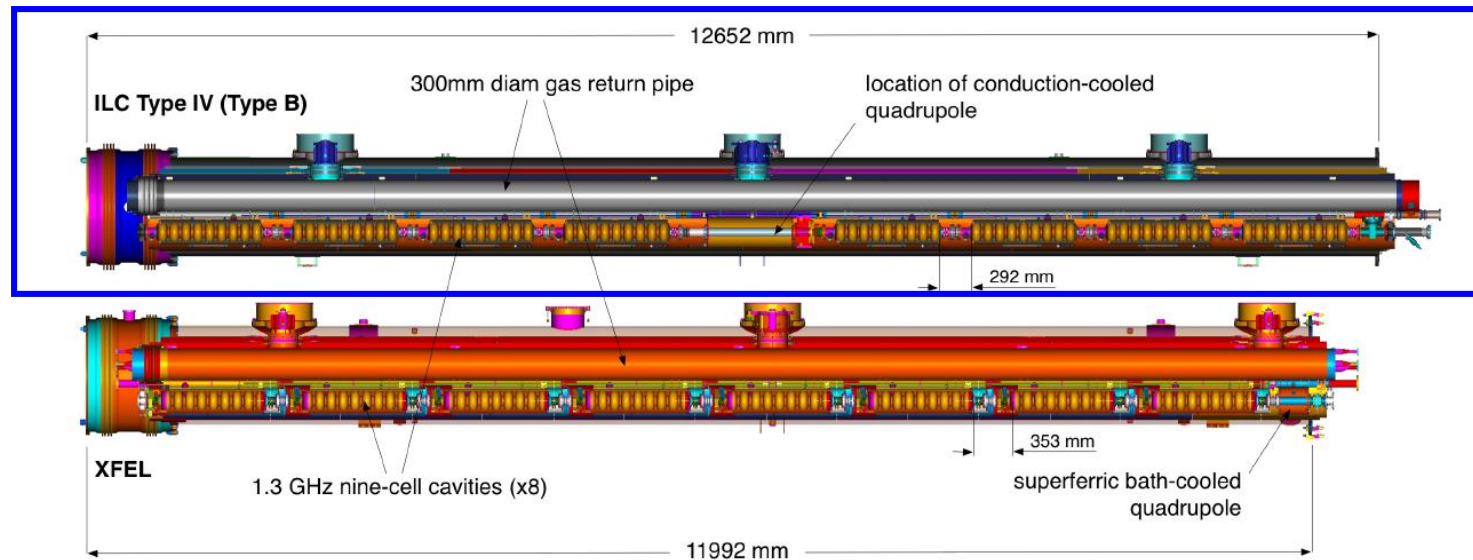
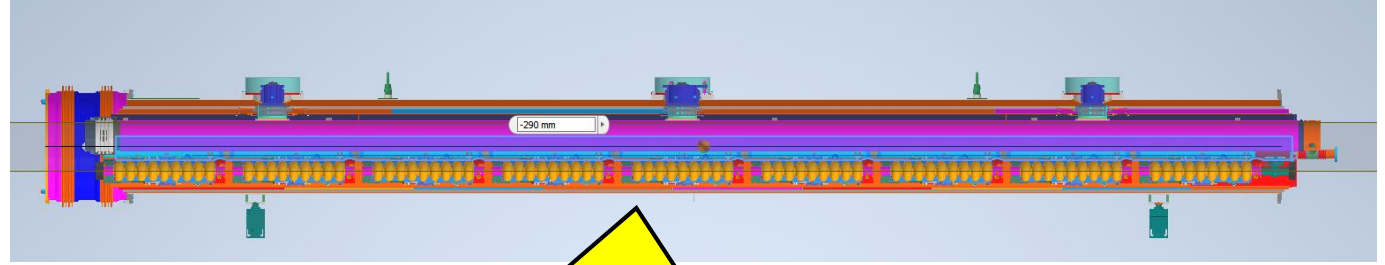
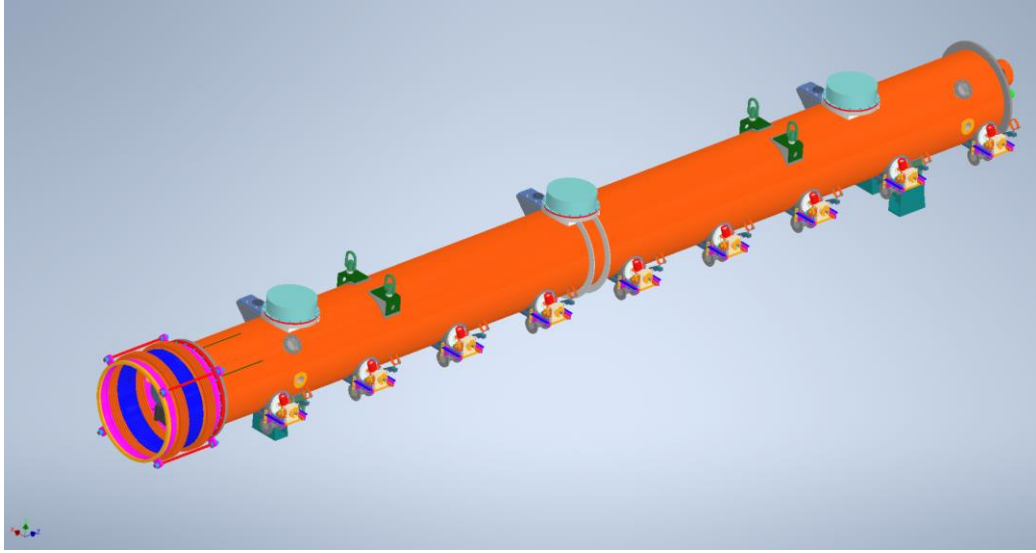
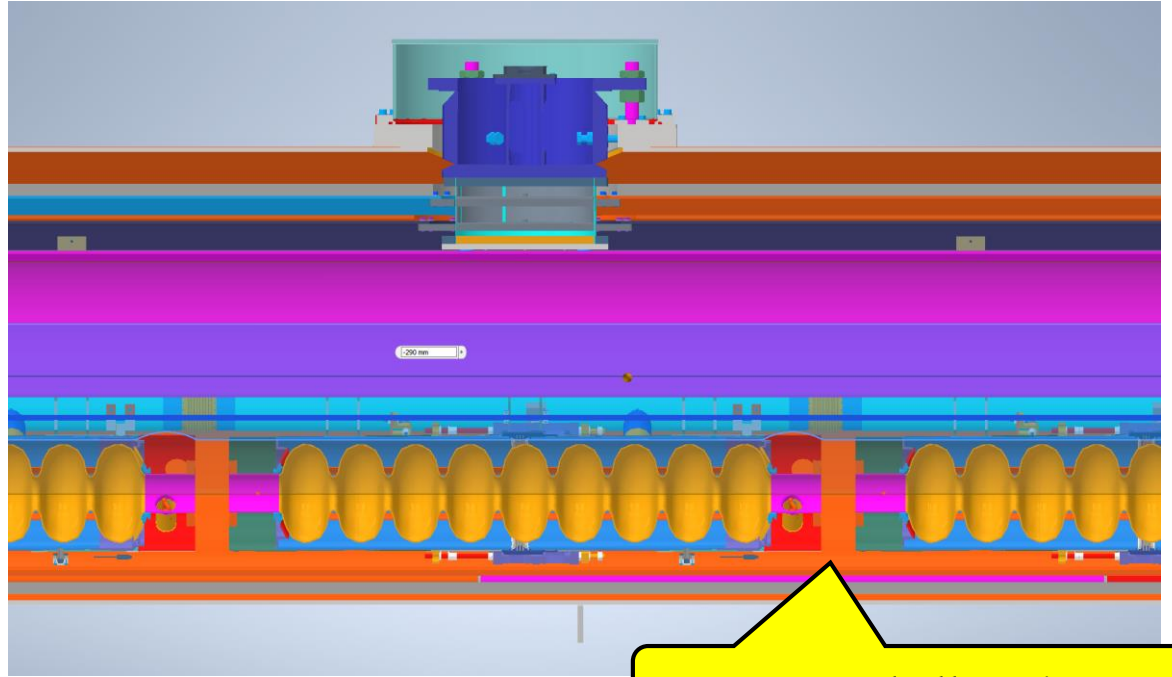

Figure 2.36. A comparison of the ILC (top) and XFEL (bottom) cryomodules. For the ILC the Type-IV module design with 8 cavities and one quadrupole package is shown. The most obvious difference is the longer length of the ILC module, driven primarily by the larger centrally located quadrupole (the longer quadrupole is required for the higher beam energy). The XFEL uses a superferric bath-cooled quadrupole located at the end of the module, while the ILC baseline locates the conduction-cooled magnet at the more stable central location. The reduced inter-cavity spacing is also indicated (ILC being 6 cm less than XFEL).

CM Drawing Data (received from Ohuchi-san)



Type-A CM (9 cavities)



No bellows!

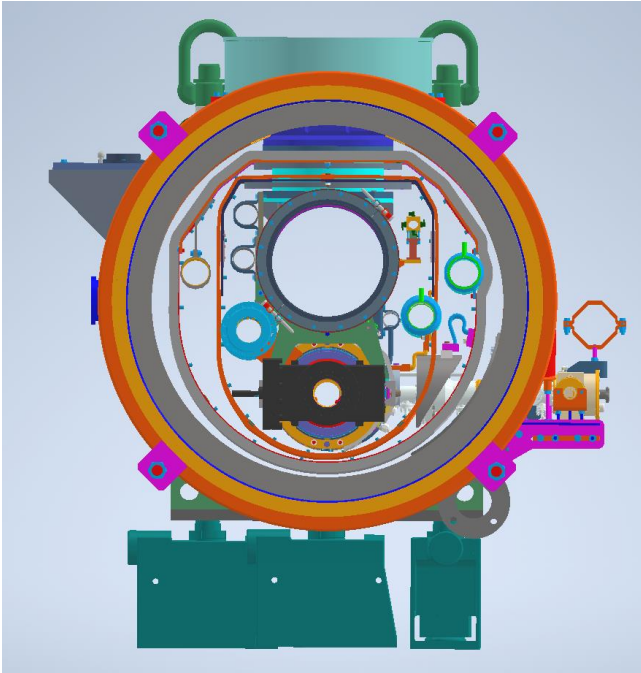

TESLA-style cryomodules compared - 1

Pipe function	BCD name	TTF inner diameter (mm)	XFEL inner diameter (mm)	Type IV (ILC) inner dia (mm)	LCLS-II inner diameter (mm)
2.2 K <u>subcooled</u> supply	A	45.2	45.2	60.2	45.0
Gas helium return header, structural support	B	300	300	300	300
5 K shield and intercept supply	C	54	54	56.1	55.1
8 K shield and intercept return	D	50	65	69.9	55.1
High temperature shield and intercept supply	E	54	65	72.0	55.1
High temperature shield and intercept return	F	50	65	79.4	52.5
2-phase pipe	G	72.1	>72.1	69.0	95.5
Helium vessel to 2-phase pipe nozzle ("chimney")		54.9	54.9	54.9	95
Warm-up/cool-down line	H			38.9	38.9

Slide by T. Peterson (Received from Akira Yamamoto-san)

Comparison of CM drawing between TDR and KEK

Figure 3.15
Representative cryo-
omodule cross section

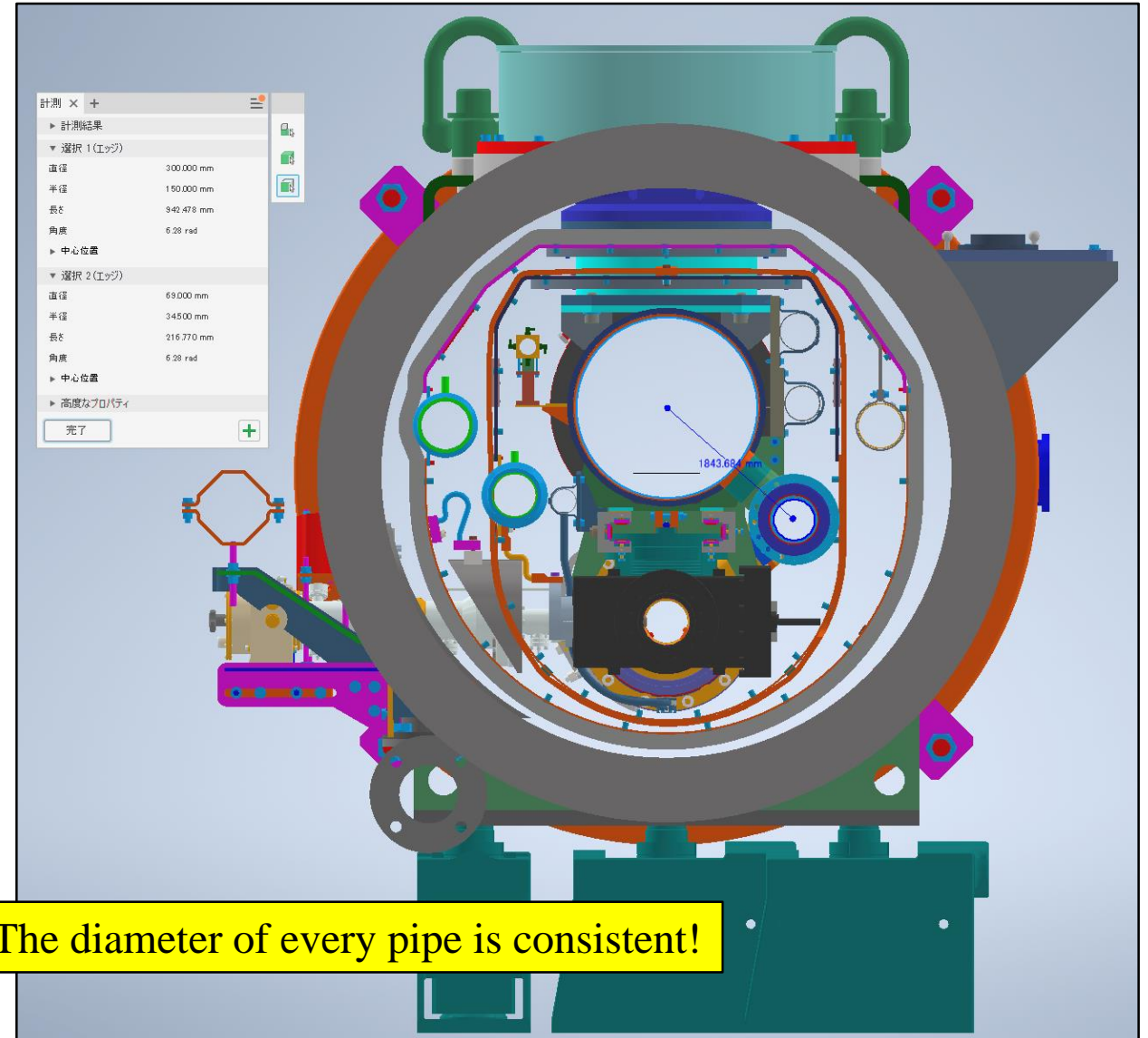
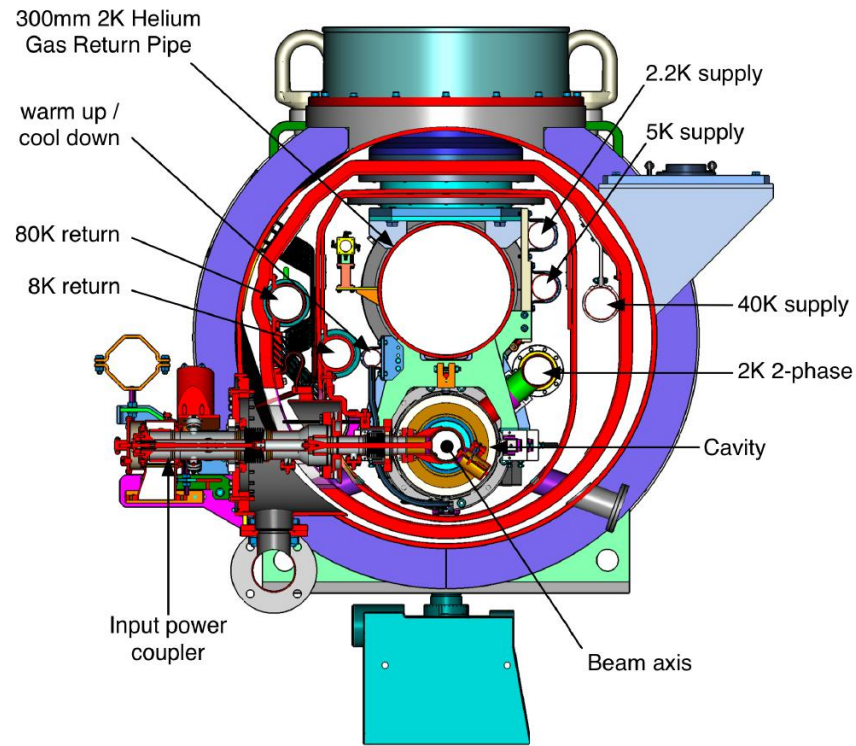

Diameter of each pipe	
Gas Return Pipe	300.0 mm
2K 2-phase pipe	69.0 mm

The diameter of every pipe is consistent!

※ Only dia. of GRP is shown in TDR

TESLA-style cryomodules compared - 2

Feature	TTF (type 3+)	XFEL	Type IV (ILC)	LCLS-II
Cavity cold slot length (mm)	1383.7	1383.7	1326.9	1383.7
Cryomodule slot length (mm)	12450	12220	12652	12220
Magnet style	Bath cooled at 4.5 K	Bath cooled at 2 K	Conductively cooled to 2 K	Conductively cooled to 2 K
Magnet location	End	End	Middle	End
Current leads	Vapor cooled from 4.5 K	Conductively cooled	Conductively cooled	Conductively cooled
BPM style				
5 K thermal shield	YES	YES	YES	NO, but retain intercepts
Input coupler	TTF3 design	TTF3 modified for better thermal intercepts		Modified TTF3 for CW cooling

Distance between input couplers

Type-B CM (8 cavities + SCM/BPM)

Table 3.5
Cavity parameters for the SRF cavities.

Parameter	Value
Type of accelerating structure	Standing wave
Accelerating mode	TM_{010}, π mode
Type of cavity-cell shape	Tesla (or Tesla-like)
Fundamental frequency	1.300 GHz
Operation:	
- Average gradient (range allowed)	31.5 MV/m ($\pm 20\%$)
- Quality factor (at 31.5 MV/m)	$\geq 1 \times 10^{10}$
Qualification:	
- Average gradient (range allowed)	35.0 MV/m ($\pm 20\%$)
- Quality factor (at 35 MV/m)	$\geq 0.8 \times 10^{10}$
- Acceptable radiation (at 35 MV/m)	$\leq 10^{-2} \text{ mGy/min}^\dagger$
Active length	1038.5 mm
Total length (beam flanges, face-to-face)	1247.4 mm
Input-coupler pitch distance, including inter-connection	1326.7 mm
Number of cells	9
Cell-to-cell coupling	1.87%
Iris aperture diameter (inner/end cell)	70/78 mm
Equator inner diameter	~ 210 mm
R/Q	1036 Ω

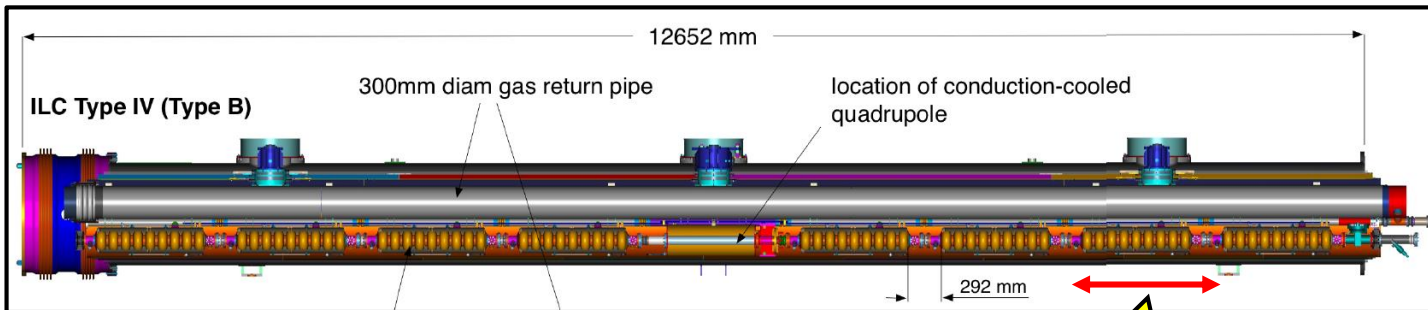

1326.7 mm
Coupler-to-coupler

1326.7 mm - 1247.4 mm = 79.3 mm (from Table 3.5)
But, from right figure, it's 82 mm!
Which is correct?

The total length of CM should be checked!

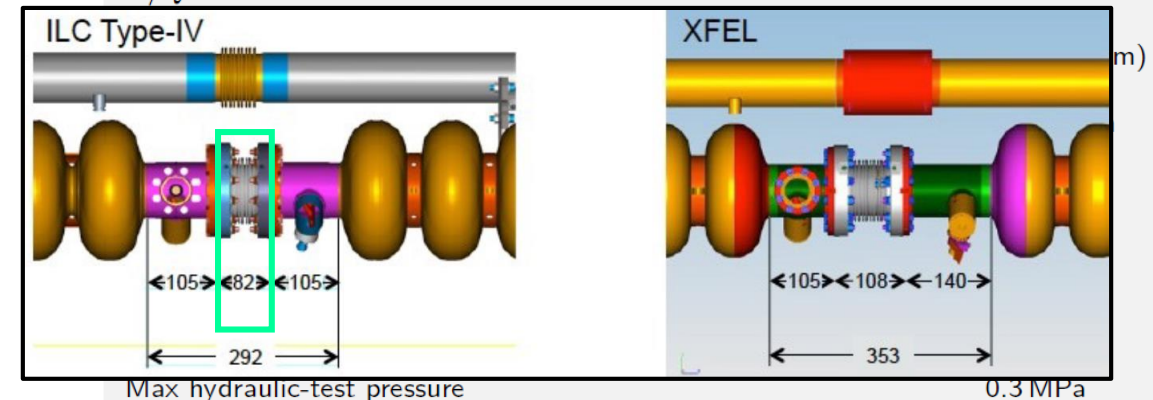

[†] Example number taken from [16] — see text for more details

Comparison of CM drawing between TDR and KEK⑤

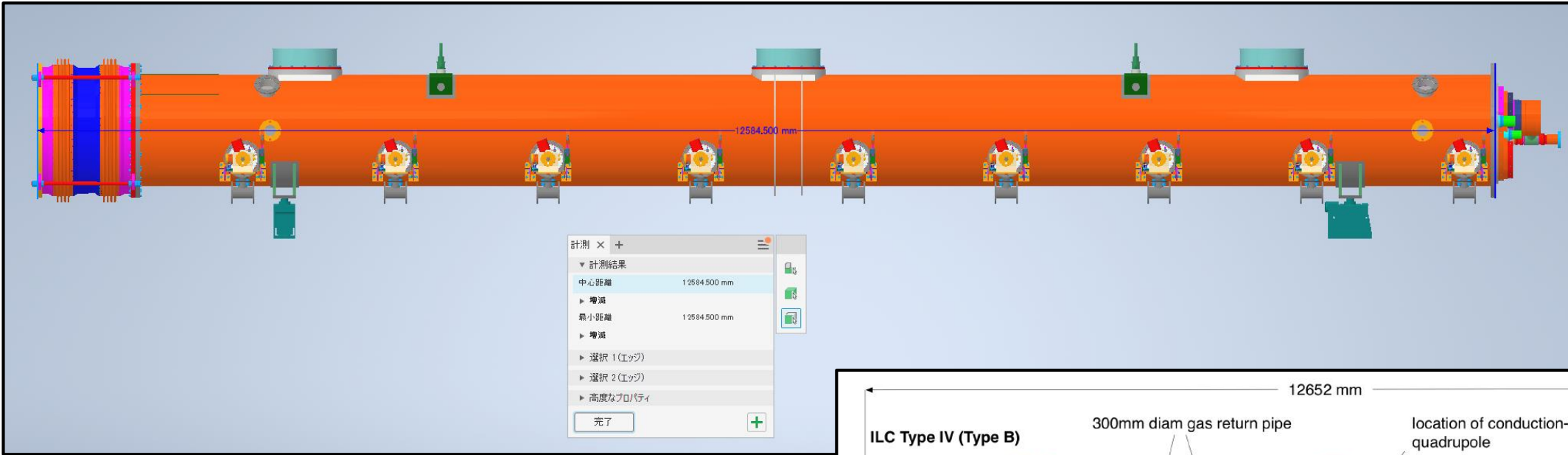

Length of CM	
KEK	12584.5 mm
TDR	12652 mm

These drawings look different from each other

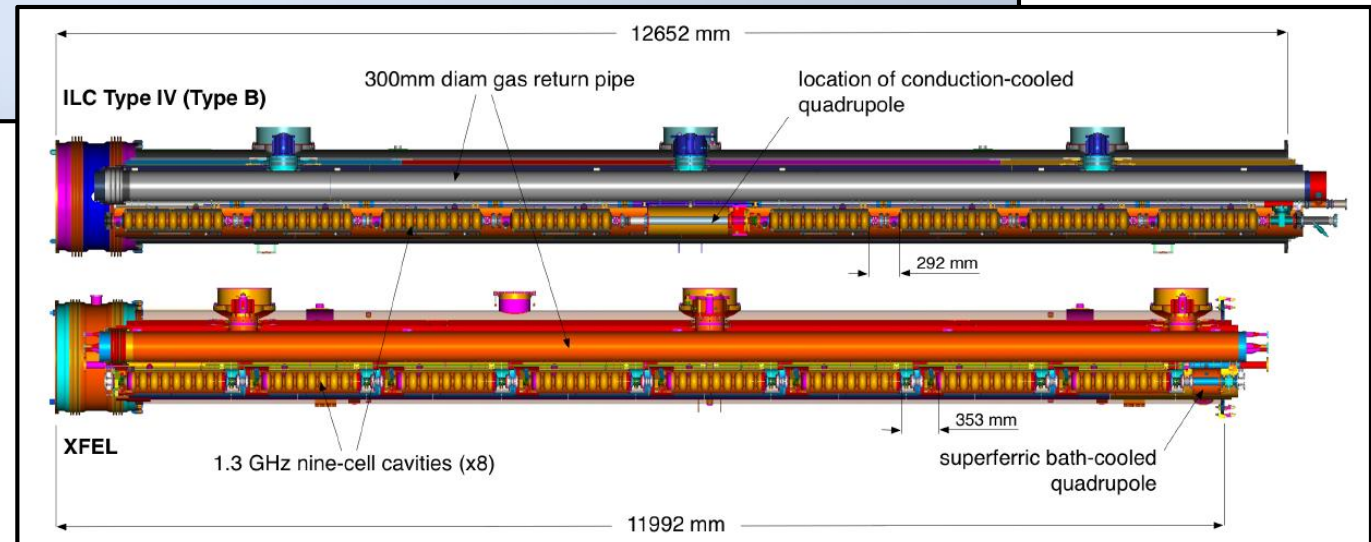

Figure 2.36. A comparison of the ILC (top) and XFEL (bottom) cryomodules. For the ILC the Type-IV module design with 8 cavities and one quadrupole package is shown. The most obvious difference is the longer length of the ILC module, driven primarily by the larger centrally located quadrupole (the longer quadrupole is required for the higher beam energy). The XFEL uses a superferric bath-cooled quadrupole located at the end of the module, while the ILC baseline locates the conduction-cooled magnet at the more stable central location. The reduced inter-cavity spacing is also indicated (ILC being 6 cm less than XFEL).

Comparison of CM drawing between TDR and KEK⑥

Distance between coupler-to-coupler	
KEK	1318.4 mm
TDR	1326.7 mm

The distance of coupler-to-coupler is shorter in KEK!

We don't understand this reason!

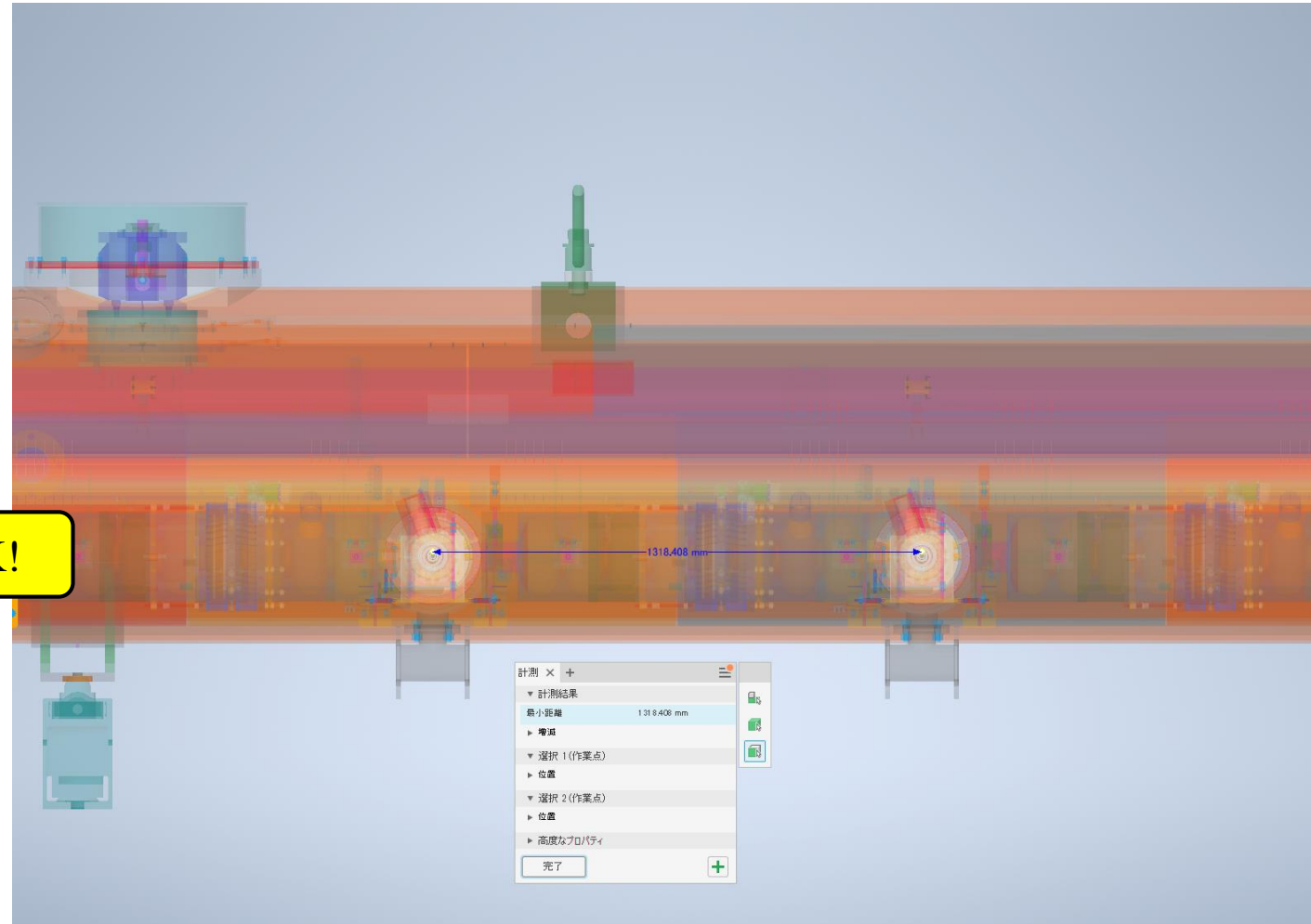

Items to consider regarding CM drawing

How long CM is available for container?

When starting CM design, we have to take care of the total length to install into container

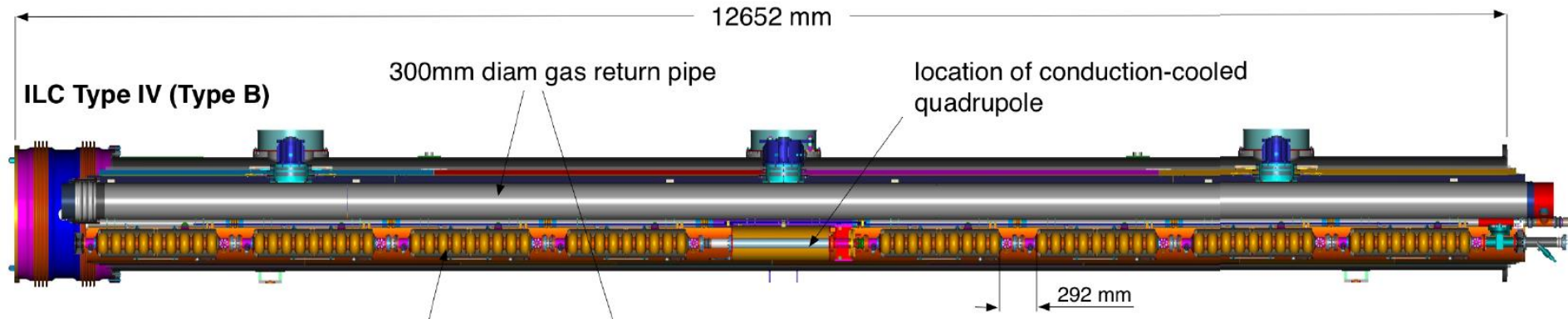

1.5 m longer, 0.3 m higher

規格	20ft	40ft	40ft (背高)	45ft
サイズ (m) (H×B×L)	2.591 × 2.438 × 6.058	2.591 × 2.438 × 12.192	2.896 × 2.438 × 12.192	2.896 × 2.438 × 13.716
最大総質量 (t)	30.480	30.480	30.480	30.480
最大積載質量 (t)	28.080	27.610	27.480	26.530
純積載容積 (m ³)	33.1	67.3	76.0	85.6

Ministry of Land, Infrastructure, Transport and Tourism of Japan

Tuner Access Port

This port is must!

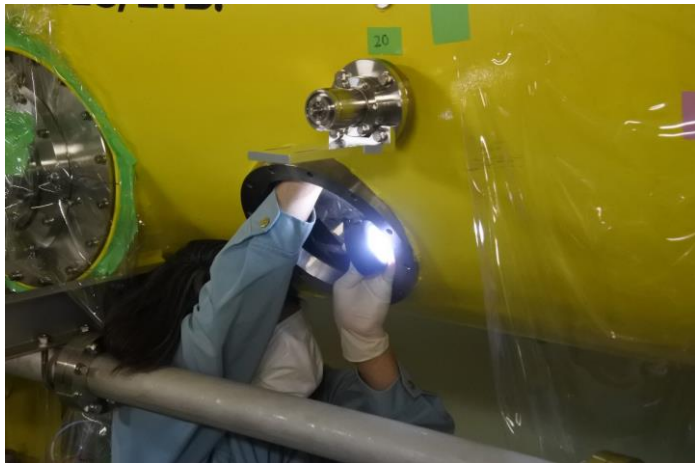

Active tuner components (electromechanical actuator & piezo-stack) need to be replaceable through special port

Tuner installed on the CM mock-up at FNAL



Function of this screw to unload tuner to replace piezo/motor



How many pre-cooling lines are necessary?

Where is the chimney position?

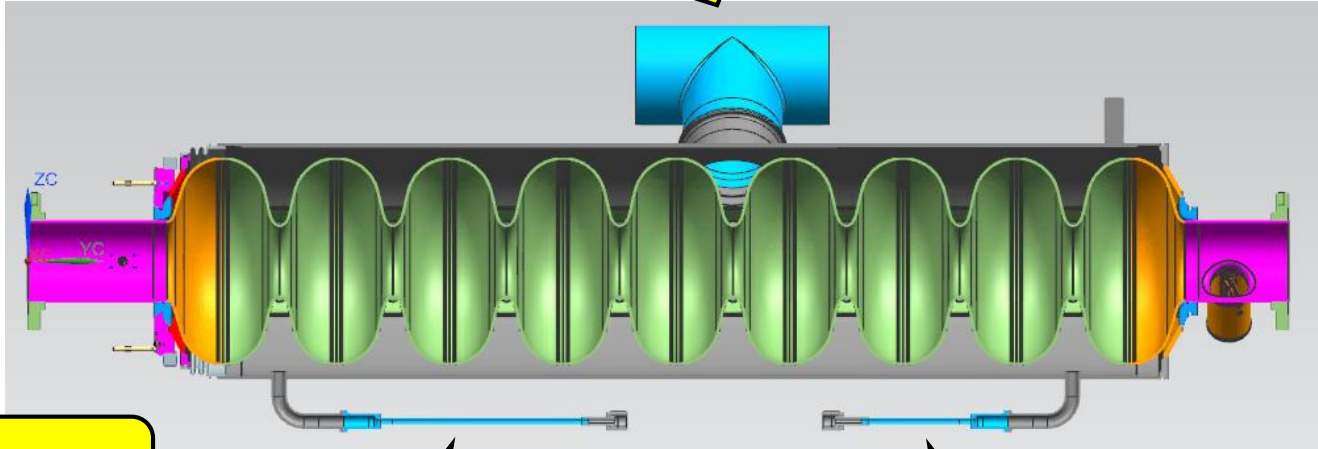

ILC needs fast-cooling?

1

2

Yuriy Orlov

Position of Chimney on Helium Tank

E-XFEL

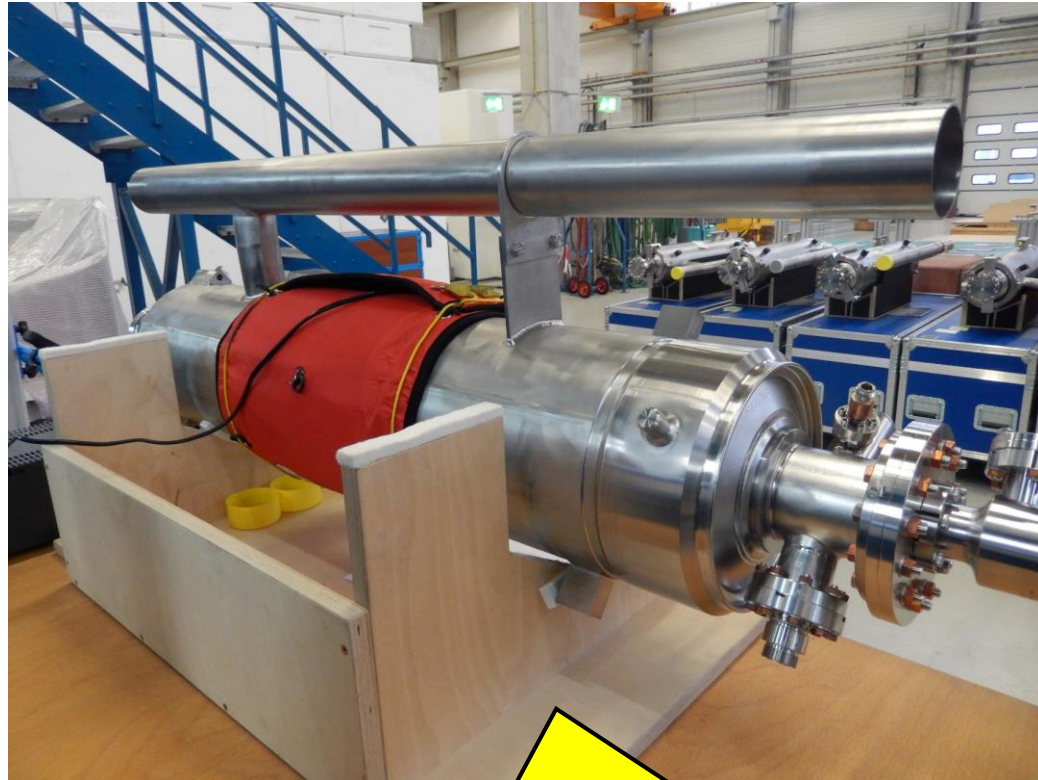

LCLS-II

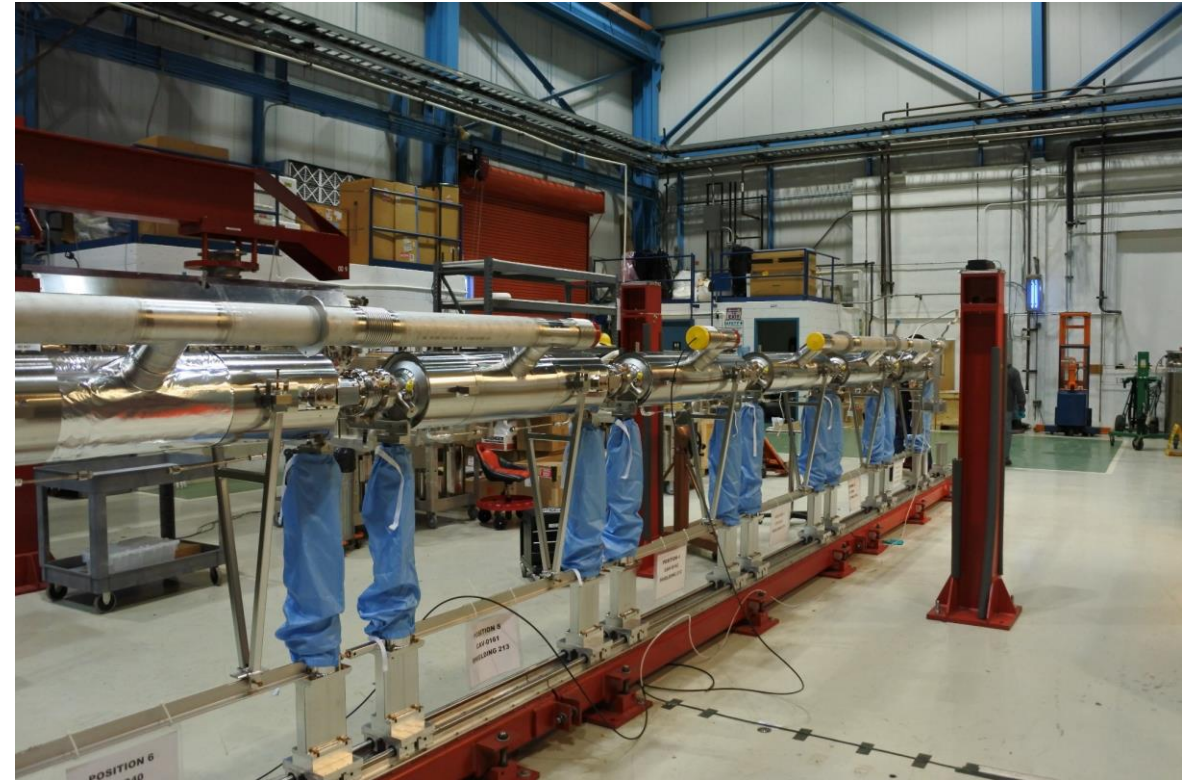

E-XFEL cavity needs additional support jig for 2-phase pipe

1.3GHz cavities (9 elliptical cells)

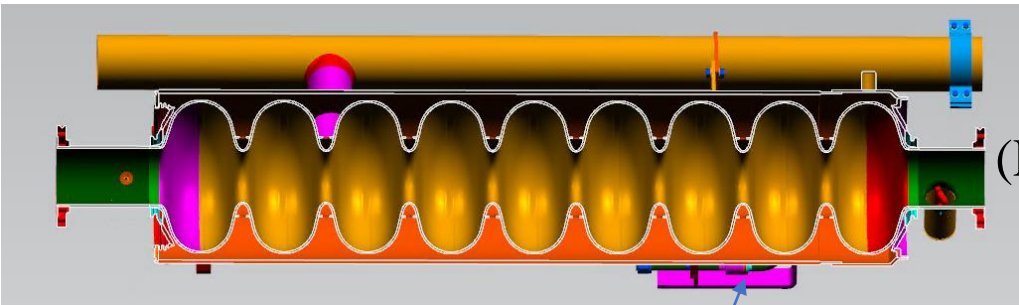

XFEL

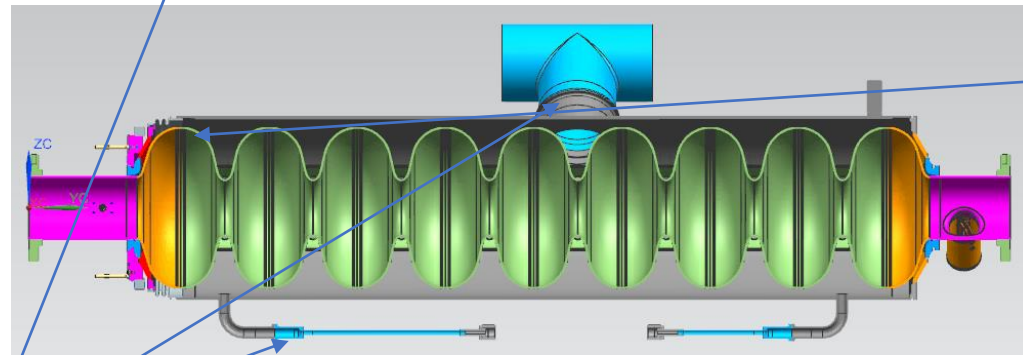

He Vessel Bellows

LCLS-II

Ti-SS
Transition

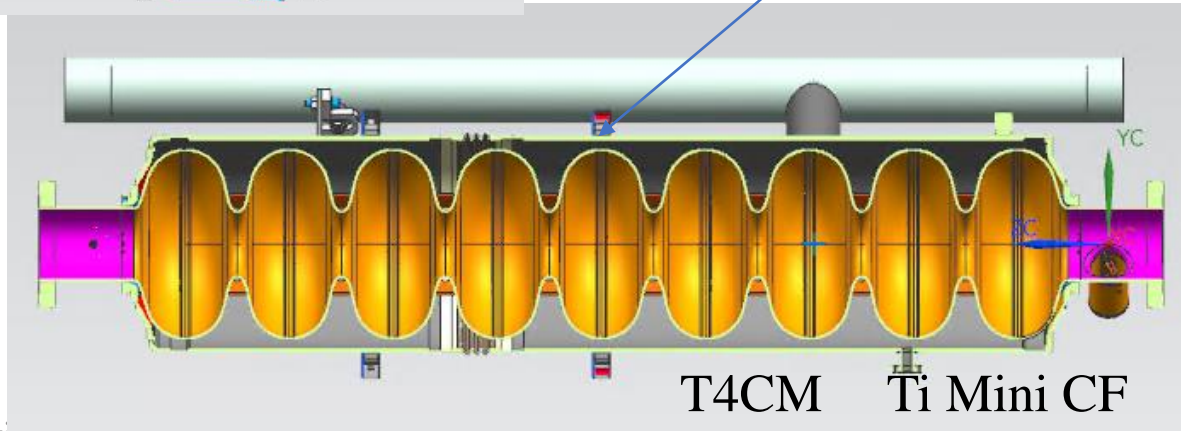

T4CM Ti Mini CF

Yuriy Orlov

Bellows and Magnetic shield

Bellows on the outside make it vulnerable to damage! Cover is necessary?

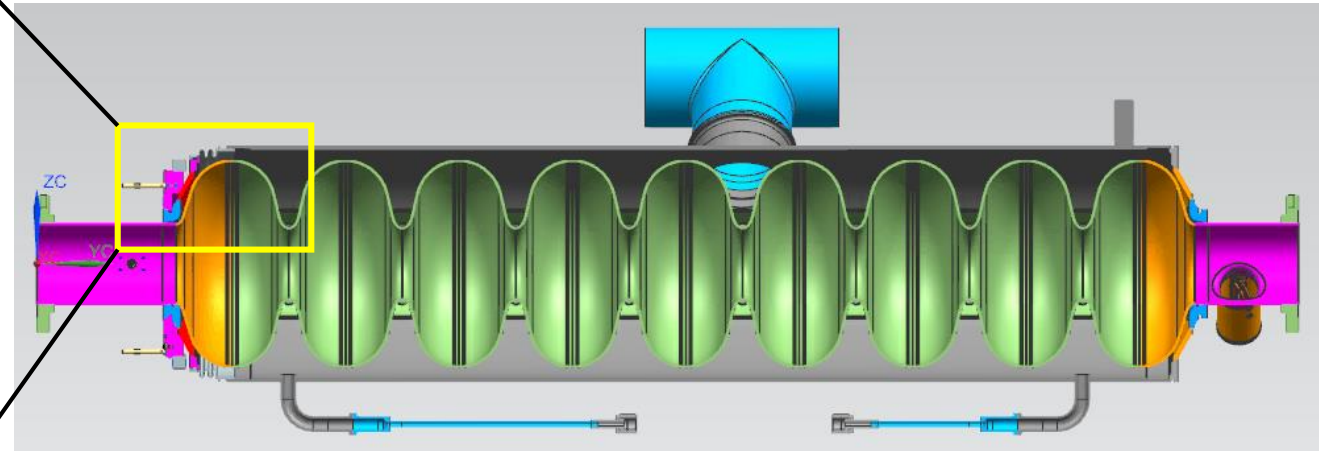
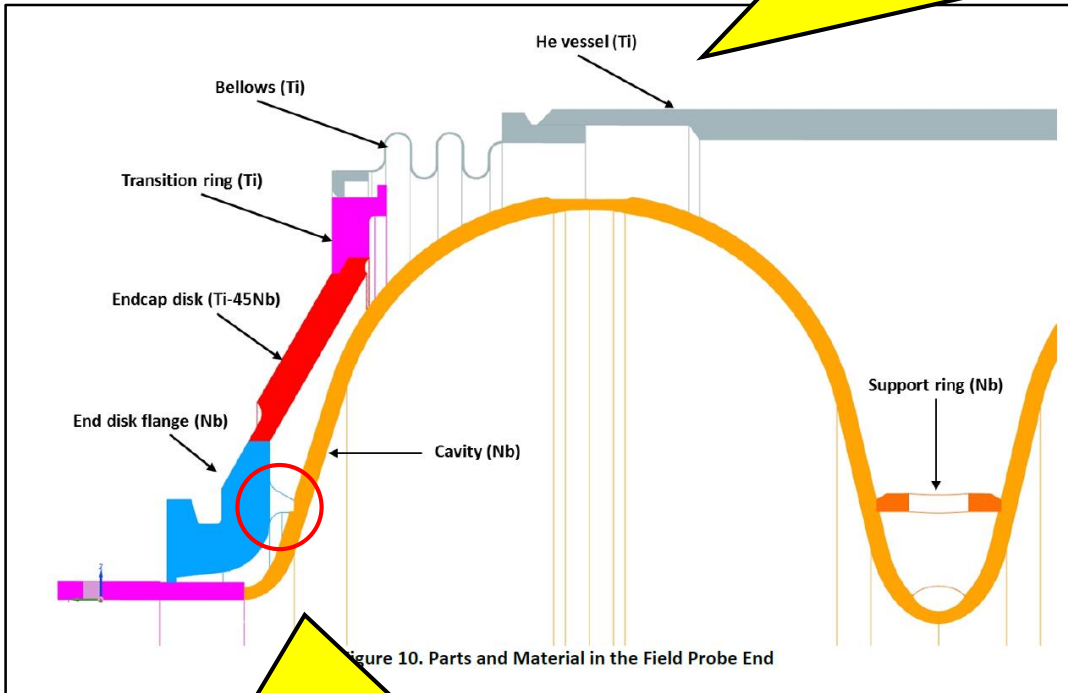

Possible to install the magnetic shield inside the helium tank

Yuriy Orlov

Comparison of Magnetic Shield

16 Components per ca (shield outside)

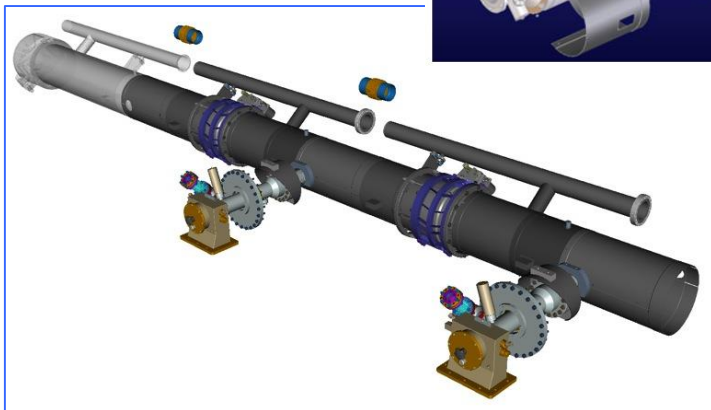
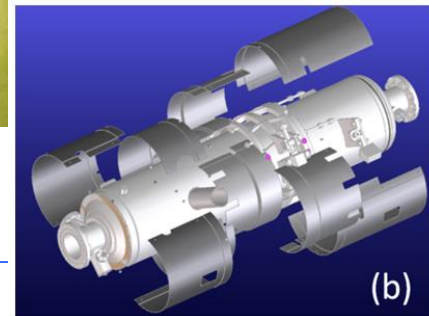

4 Components per Cavity (shield inside)

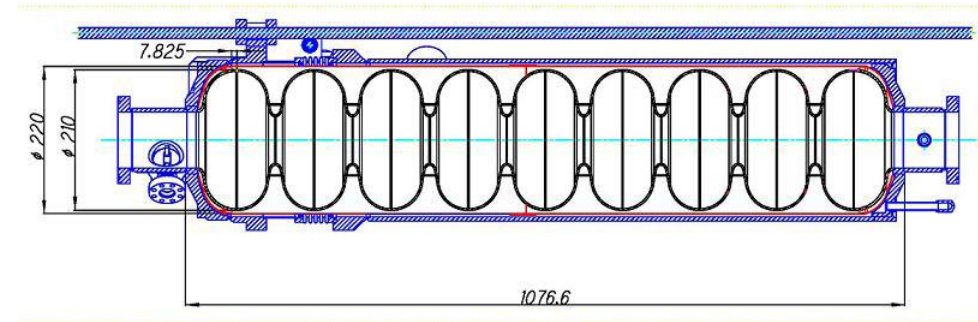

Double Magnetic Shields in LCLS-II

Double magnetic shields are obviously expensive!
Contrary to the spirit of cost reduction

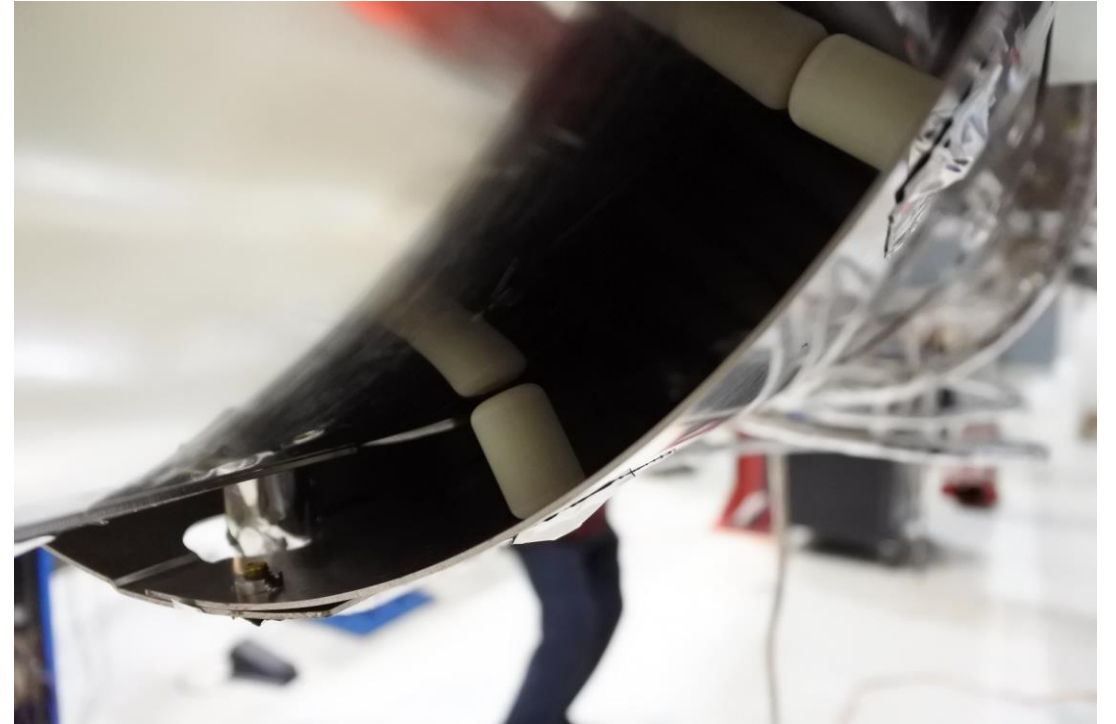

5K Thermal Shield

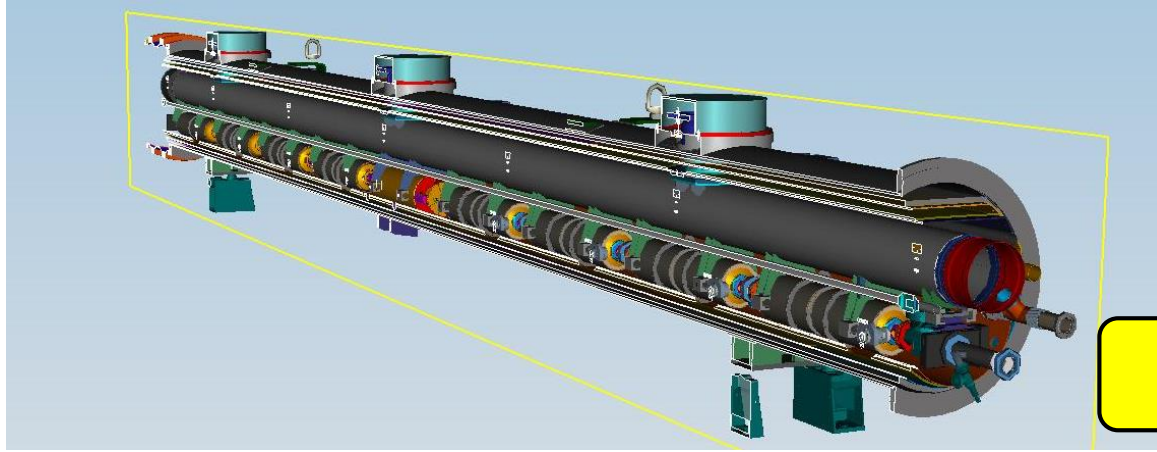

Lower part of 5K shield is necessary?

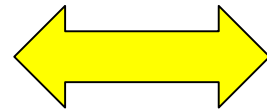
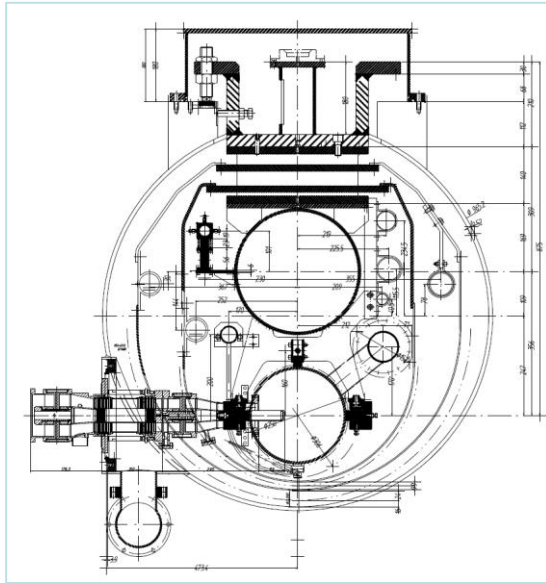

Vacuum vessel
= ϕ 965.2mm

Two shield model

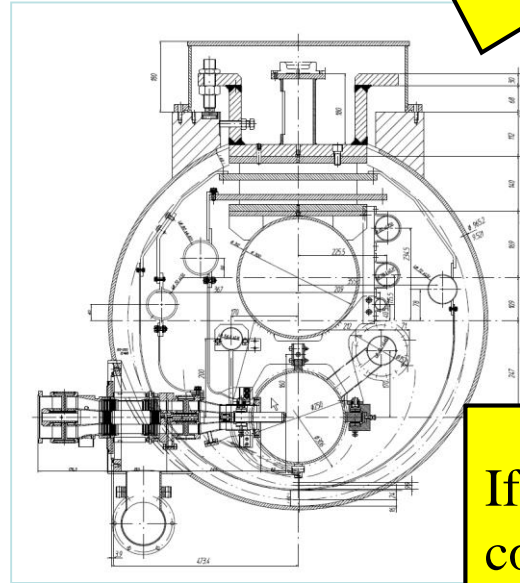

If 5K shield removed, position of cooling pipes and diameter are changed

One shield model

Tuners

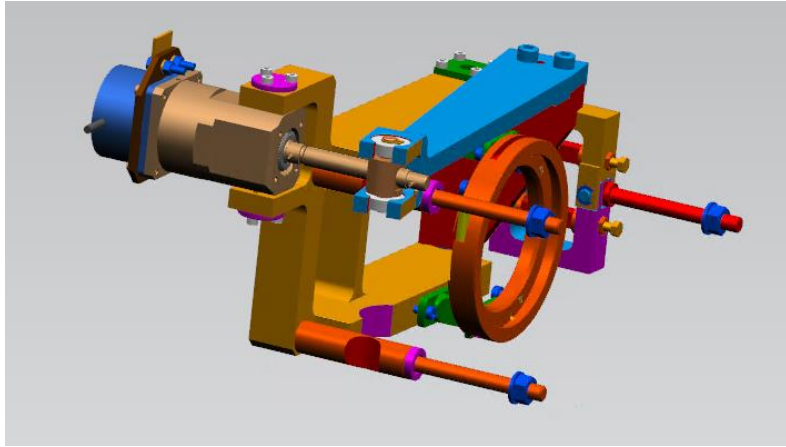

XFEL

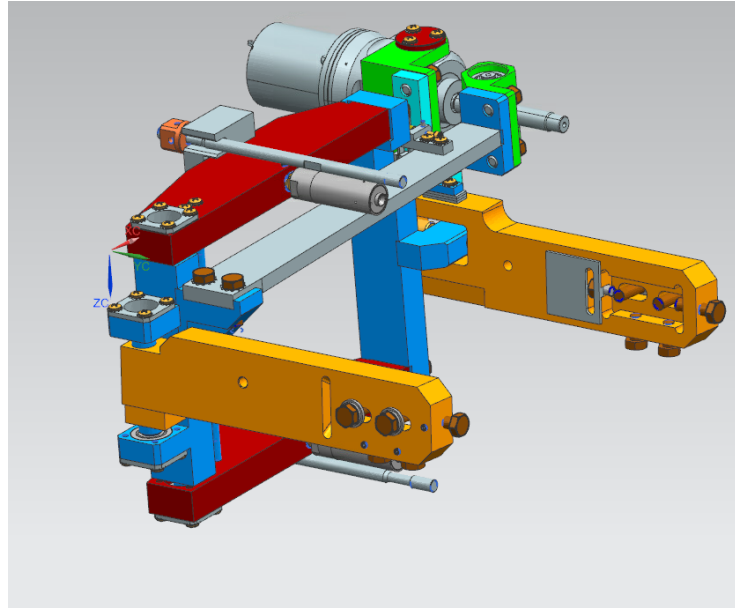

LCLS-II

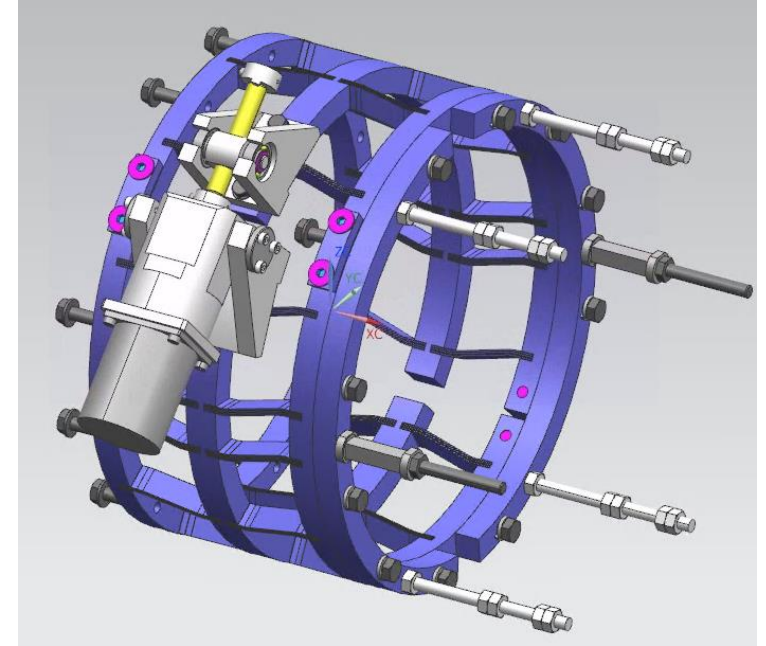

T4CM

Yuriy Orlov

Proposal to test a WARM dressed cavity with the tuner installed

Setup for WARM Tuner/Cavity (AES027) study

COLD Transfer Function

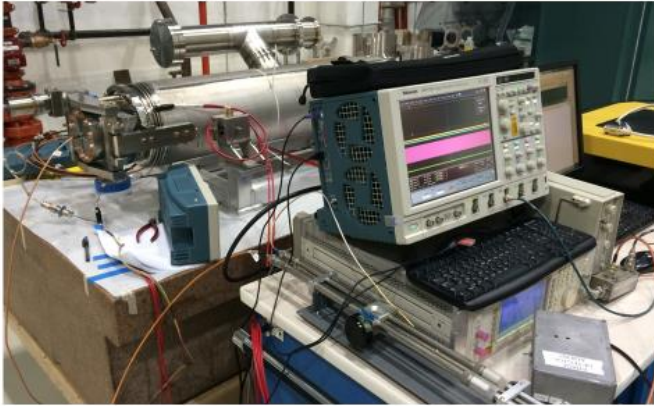

WARM Cavity Transfer Function (Piezo-to-Cavity)

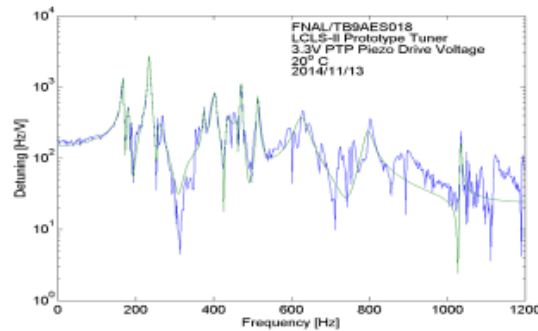

#	f(Hz)	tau(ms)	kappa(Hz/V)	Strength
1	235	49	14.5	0.65
2	168.1	41	6.86	0.1
3	471.2	46	5.79	0.09
4	402.2	17	1.29	0.04
5	232.6	126.4	1.29	0.03

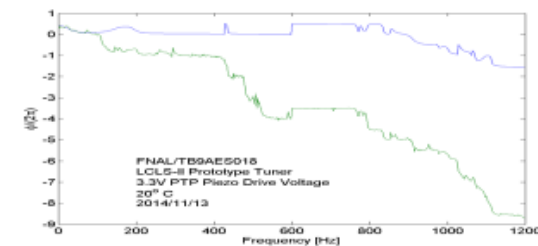

Cavity driven with 3.3Vpp sinusoidal drive signal and frequency was stepped between 1Hz to 1200Hz with increment of 1Hz.
Forward and probe signals feed of an AD8032 analog phase detector.
Output digitized for 5sec interval at rate of 10kHz.

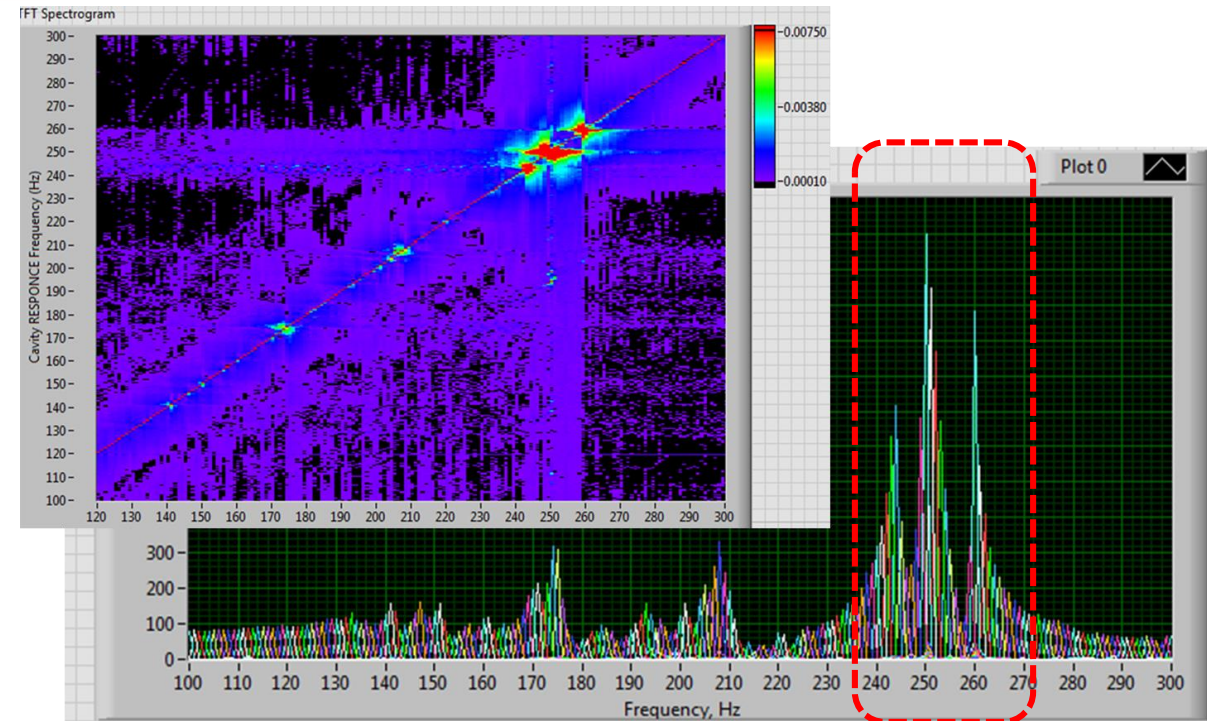

Very strong correlations between measurements of WARM vs. COLD transfer functions

Y. Pischalnikov

Horizontal Test System for Single Cavity

Horizontal Test Area @AR-E Lab. in KEK

Horizontal Test Area @NML in FNAL

We need the demonstration of tuner drive at horizontal test

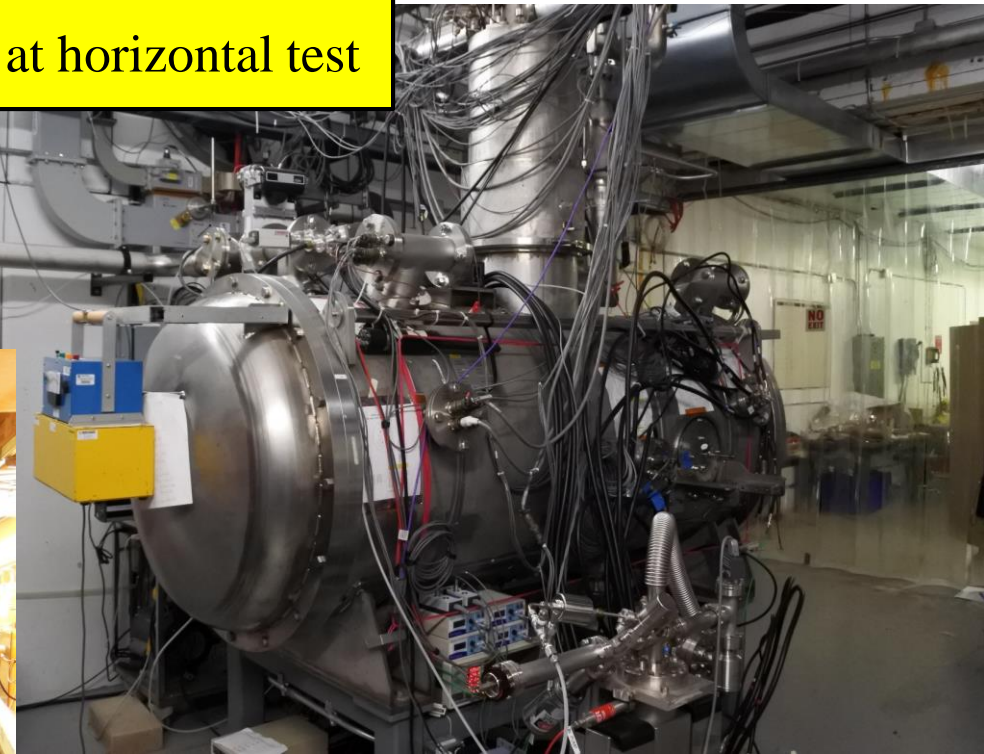
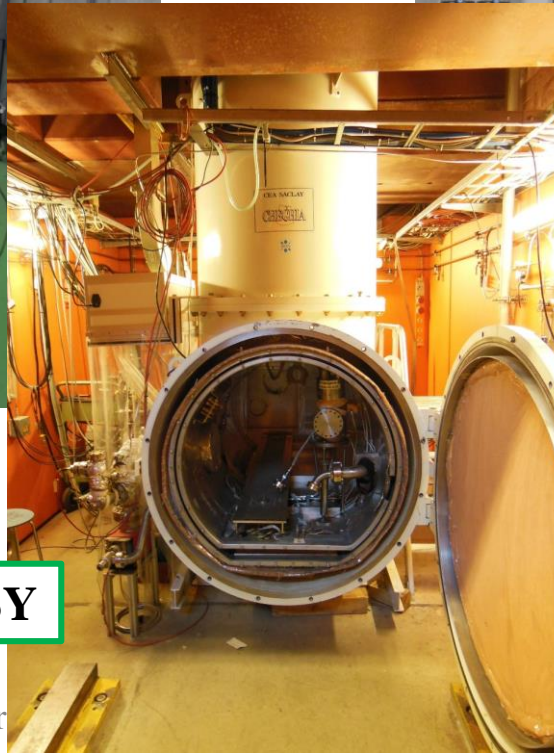

Horizontal Test Area @HALLE3 in DESY

Helium inventory in LCLS-II

Location	Number of modules	State	Temperature (K)	Pressure (bar)	Pipe ID (mm)	Density (kg/m ³)	Volume (liters)	Mass (kg)	Equiv liquid (4.2 K liters)
One helium vessel		liquid	2.00	0.031		145.700	23.00	3.35	26.8
8 helium vessels	1	liquid	2.00	0.031		145.700	184.00	26.81	214.5
2-phase pipe liquid	1	1/2 dia liquid	2.00	0.031	95.0	145.700	43.22	6.30	50.4
2-phase pipe vapor	1	1/2 dia vapor	2.00	0.031	95.0	1.008	43.22	0.04	0.3
300 mm pipe vapor	1	vapor	2.00	0.031	300.0	1.008	861.93	0.87	7.0
5 K supply	1	supercritical	5.00	5.000	56.1	129.000	30.14	3.89	31.1
8 K return	1	supercritical	8.00	4.000	69.9	30.760	46.79	1.44	11.5
30 K supply	1	gas	30.00	16.000	72.0	24.660	49.65	1.22	9.8
50 K return	1	gas	50.00	14.000	79.4	12.970	60.38	0.78	6.3
Warmup line	1	vapor	2.00	0.03	38.9	145.700	14.49	2.11	16.9
TOTALS									
One module	1						1333.81	43.46	347.7
LCLS-II module total	37						49351.07	1608.18	12865.4

Each dressed cavity – 27 liquid liters

8 dressed cavities – 214 liquid liters

Pipes – 134 liquid liters equivalent mass

One cryomodule total – 348 liquid liters equivalent

LCLS-II cryomodules – 13,000 liquid liters equivalent

ILC needs the summary table as this, including length, material, operating pressure, maximum allowable working pressure, etc.

T. Peterson - LCLS-II Cryomodule Design - 7 Oct 2014

Progress of HPGS

- ◆ Visit to local government in Ibaraki-ken prefecture (KEK Tsukuba campus) to discuss HPGS
 - ◆ Three times: 3/Mar, 23/Apr, 21/May
 - ◆ Discussion time per meeting: 2~3 hours
- ◆ Looks like the discussion is going toward good direction
- ◆ To be checked the max. allowable pressure value (see next page)
- ◆ Legal handling changes depending on whether it is 160 mm (dia.) or more or less
 - ◆ How about GRP of 300 mm?
- ◆ Not discussed yet when testing CM abroad
 - ◆ Before testing CM performance, inspection by authorized person of HPGS should be done
- ◆ Need to be inspected separately even if the vendors are different?

Max. allowable pressure described in TDR

3.4.2.5 Cryogenic lines in the module

The following helium lines [32] are integrated into the cryomodules, as shown in Fig. 3.15.

- The 2 K supply line transfers pressurised single-phase helium through the cryomodule to the end of the cryogenic unit.
- The titanium 2 K two-phase supply line is connected to the cavity helium vessels. It supplies the cavities with liquid helium and returns cold gas to the 300 mm GRP at each module interconnection.
- The 2 K GRP returns the cold gas pumped off the saturated He II baths to the refrigeration plant. It is also a key structural component of the cryomodule
- The 5–8 K supply and return lines. The 5 K supply line is used to transfer the He gas to the end of the cryogenic unit. The 5–8 K return line directly cools the 5–8 K radiation shield and, through the shield, provides the heat-flow intercept for the main coupler and diagnostic cables, and the HOM absorber located in the module interconnection region.
- The 40–80 K supply and return lines. The 40 K supply line is used to transfer He gas to the cryogenic unit end and cools the high-temperature superconductor (HTS) current leads for the quadrupole and correction magnets. The 40–80 K return line directly cools the 40–80 K radiation shield and the HOM absorber and, through the shield, provides an additional heat-flow intercept for the main coupler and diagnostic cables.
- The warm-up/cool-down line connects to the bottom of each cavity helium vessel.

The helium vessels surrounding the cavities, the two-phase supply line and the GRP operate at low-pressure conditions (30 mbar, corresponding to 2 K) while all other cryogenic lines operate at a maximum pressure of 20 bar.

3.5.4 Pressure code compliance

The niobium RF cavities limit the maximum allowable pressures at the 2 K level of the cryogenic system. In North America, Europe, and Asia, the titanium helium tanks which surround niobium RF cavities, and part or all of the RF cavity itself, fall under the scope of the local and national pressure vessel rules [33]. Thus, while used for its superconducting properties, niobium must be treated as a material for pressure vessels. Problems with the certification of pressure vessels constructed partially or completely of niobium arise due to the fact that niobium and titanium are not listed as acceptable vessel materials in pressure vessel codes. Considerable effort has been expended in all three regions to gain compliance with pressure vessel codes and permission from authorities to operate ILC-style cryomodules, which contain these exceptional pressure vessels.

Partly due to the constraints of pressure code compliance, and partly to avoid detuning of the RF cavities by high-pressure helium, the cavity helium vessels and associated low-pressure piping (30 mbar corresponding to 2 K), have a Maximum Allowable Working Pressure (MAWP) of 2 bar differential. A higher MAWP for liquid-helium temperature conditions may be established, if necessary, to accommodate pressures during emergency venting with loss of vacuum. Other piping such as the 2 K helium-supply pipe and thermal-shield lines will be rated for 20 bar differential pressure.

Details regarding methods to achieve compliance with pressure codes and permission to operate low-temperature containers made from niobium and titanium will depend on the legal requirements of the regions involved. Documentation and required testing pressures and procedures are not uniform around the world. Testing in one region and operation in another may invoke multiple sets of rules. Laboratories involved in ILC cryomodule development have established methods to satisfy local codes and demonstrate the safety of these systems, sometimes including special arrangements with local authorities for these exceptional vessels. Careful consideration and agreements between all the involved regional authorities will be required for the distributed mass production, testing and finally operation of the cryomodules.

4-year-profile of cost for TPP

Recently, 4-year-profile of cost based on ILC action plan was revised for TPP

Year/Date	Items	8/Jun/2021											Sum (Oku-Y)	Japan (FTE-yr)	Abroad (FTE-yr)
		Japan					Abroad								
		P1 (Oku-Y)	P2	P3	P4	Sum	P1 (Oku-Y)	P2	P3	P4	Sum				
1	[WP-1] Cavity Industrial-Production Readiness -Cavity industrial-production readiness to be demonstrated (JP:40, AB: 80)														
2	[WP-2] Cryomodule (CM) Assembly, Global Transfer and Performance Assurance -Ancillaries production (Coupler/Tuner/SCM) (JP:2, AB:4) -CM production (JP:2, AB:4) -CM performance assurance, CM string assembly (2 CMs) -CM Global transfer, Performance assurance after transport														
3	[WP-3] Crab Cavity System														
4	[Infrastructure-A]]KEK-STF Beam Operation Demonstration (1.5 CM + 0.5 CM) -Tunnel expansion, cryogenics and klystron gallery upgraded -Upgrading STF accelerator (+0.5 CM)														
5	[Infrastructure-B] KEK-STF/COI Hub-lab. Functionality (production, assembly, test) -Cavity fabrication facility (Wire-saw, EBW-renewal, etc) -VT system with four cavities -CM assembly/production incl. cavity string assembly -CM test area (2 CMs available) -Cryogenics system upgraded (separated from STF) -HLRF/LLRF system installed -Horizontal Test Area with single cavity (STF: coupler/tuner) -COI building expansion for CM string														
6	[Infrastructure] Upgrading Abroad hub-lab. Functionality (production, assembly, test)														
7	Electric power, Maintenance work for testing, assmebly work														
8	EDR and Construction/Project Preparation (Documentations)														
Sum															

Update of scope/deliverable in WBS (Overall/WP-1)

#	Code	Title		Scoping statement	Deliverables
56	2	SRF Technology		Design and prototype the SRF and HLRF components and subsystems	Key performance figures; design of SRF and HLRF components and systems; input to cost estimation; CFS requirements; Prototype modules; EDR volume "SRF technology"
57	2.1		ML and SRF system design (overall management)	Design complete RF units and cryo strings (for Main Linac, Bunch Compressors and 5GeV boosters in Sources)	Layout of RF units and cryo strings; CFS requirements; Chapter for EDR
58	2.2		WP01: Cavity production (Incl. ML DR, & others)	Demonstrate cavity production readiness	Final cavity design; final surface treatment recipe; testing recipe; cost estimate; performance specification; 120 prototype cavities; Chapter for EDR
59	2.2.1			SC material	Final material definition; standard specification for 120 prototype cavities
				baseline/cost-down material to be decided (before TPP?)	Decide the baseline before TPP
60	2.2.2			Cavity production/surface-process	Drawings of cavity package, Manual for baseline surface process/ Completion of 120 cavity production (40 per region), for the success yield evaluation and for 2 CM assembly (16 per region).
				baseline/cost-down surface-process to be decided (before TPP?)	Completion of 120 cavity production (40 per region), for the success yield evaluation and for 2 CM assembly (16 per region).
				high pressure gas safety regulation	Final document to be submitted to authority Receive the safety inspection result (certificate) to be approved by the HPGS authority in Japan.
61	2.2.3			HOM coupler (measurement and tuning?)	Tuning range of HOM coupler; Material for use
62	2.2.4			Helium tank and magnetic shield	Final material definition; material for 120 prototype cavities; Drawing of helium tank and magnetic shield
				tuner design	Drawing of tuner
				Vertical Test + Success Yield Verification	Success yield result and to satisfy the success yield fraction of 90 % to reach the ILC SRF cavity performance of E = 35 MV/m (+/-20%) at Q ≥ 0.8E10 with sufficient statistics by using about a half of 40 cavities per region.
				Infra-structure and Test Facilities: JP	Realization of the necessary facilities, utilities, and the Hub-Lab functioning.

Update of scope/deliverable in WBS (WP-2)

#	Code	Title		Scoping statement	Deliverables
63	2.3		WP02: Cryomodule assembly, transfer, and performance assurance	Demonstrate cryomodule production/assembly readiness, and realize global CM transfer across oceans, and confirm the CM performance assurance.	Final cryomodule design; transportation plan; standards for cryomodule production and operation permit; plug compatibility interface specification; cost estimate; 6 prototype cryomodules; Chapter for EDR. - 6 CMs completion (2 per each region) with the plug-compatibility to be connected to each other and with satisfying the HPGS regulation in Japan. - 2 CMs (one from Europe and one from Americas) transported to Japan, and the performance assured to satisfy the ILC performance specification of $E = 31.5$ MV/m (average) and $Q \geq 1$ E10 (average).
64	2.3.1			CM Horizontal Test + Degradation Mitigation (before and after transport) CM Transport (categorized into 4 items as follows)	Test capabilities for cavities and cryomodules in all three regions; Success yield plot in CM test - 2 CMs (one from Europe and one from Americas) transported to Japan, and the performance assured to satisfy the ILC performance specification of $E = 31.5$ MV/m (average) and $Q \geq 1$ E10 (average). - Confirmation of the CM performance maintained after the CM string (actually two CMs in Pre-Lab phase) connection work.
				Transport design	Design cage/shock damper Establish the safe CM transport technology and process, with ship-transport across the oceans.
				Mock-up CM transport twice	Trailer size should be checked Confirm the transport scheme including physical size and transportation by using the transport cage adaptable for both ground transportation and sea shipment.
				Global transport	Container size should be checked Demonstrate the safe CM transport across the oceans.
				Returning transport	if necessary, Confirm capability of the CM transport, even after the CM test in Japan, for reconfirmation of the performance reproducibility after transport repeated.
65	2.3.2			Tuners	Establish the design and fabricate tuners in cooperation with WP1. Final tuner design and drawings; cost estimate; Complete 60 prototype tuner production to be assembled into the 6 CMs (2 CMs per region).
66	2.3.3			Couplers	Establish the design and fabricate couplers in cooperation with WP1. Final coupler design and drawings; cost estimate; Complete 60 prototype coupler production to be assembled into the 6 CMs (2 CMs per region).
67	2.3.4			Quad/BPM Package	Establish the design and fabricate cryomodule quad/BPM/corrector packages Final quad/BPM package design and drawings; cost estimate; Complete 6 prototype packages to be assembled into the 6 CMs (2 Cms per region).
68	2.3.5			Cold mass and V. Vessel (CM design/fabrication/assembly + Inter-connect)	Establish the design and fabricate cryomodule cold mass Drawing of CM; cost estimate; Complete 6 Type-B CM cold-mass.
				high pressure gas safety regulation	Discussion with authority/Sample test/Mechanical simulation/Documentation Establish the guideline to adapt to HPGS regulation in Japan, and globally optimize the CM fabrication process to be adaptable to the safety regulation in Japan. Final document to be submitted to authority and local government Receive the safety inspection result (certificate) to be approved by the HPGS authority in Japan.
				Hub-Lab, CM H. Test Facilities, coupler process (Infra: JP)	Establish and demonstrate the Hub-Lab function for supervising the SRF CM production and performance verification. Realization of the necessary facilities, utilities, and the Hub-Lab functioning.

Update of scope/deliverable in WBS (WP-3)

#	Code	Title		Scoping statement	Deliverables
69	2.4		WP03: Crab cavity	Design crab cavity system	Final crab cavity design; cost estimate; Chapter for EDR
				CC design including coupler, tuner etc. Establish the baseline design with downselection to two crab cavity packages, Design crab cavity, coupler, tuner	Design prototype crab cavity with two designs Complete the design document and drawings for the prototype fabrication.
				CC model and prototype production Fabricate the prototype crab cavities and evaluate the performance.	Complete 2 x 2 prototype (one is for model work) crab cavities and their performance tests with confirmation of the CC performance required for the ILC.
				Vertical test including harmonized operation Downselect one crab cavity design based on the evaluation of the two prototypes.	Test result from VT with two crab cavities Complete the downselect process and the documentation for the process.
				CC-CM design Establish the CC-CM design	Final design CC-CM Complete the engineering design work and the final design documentation
				WP3: CC Infra-structure (TBC)	

Tentative summary of WBS related to SRF

We need to consider the other materials than TPD for WBS

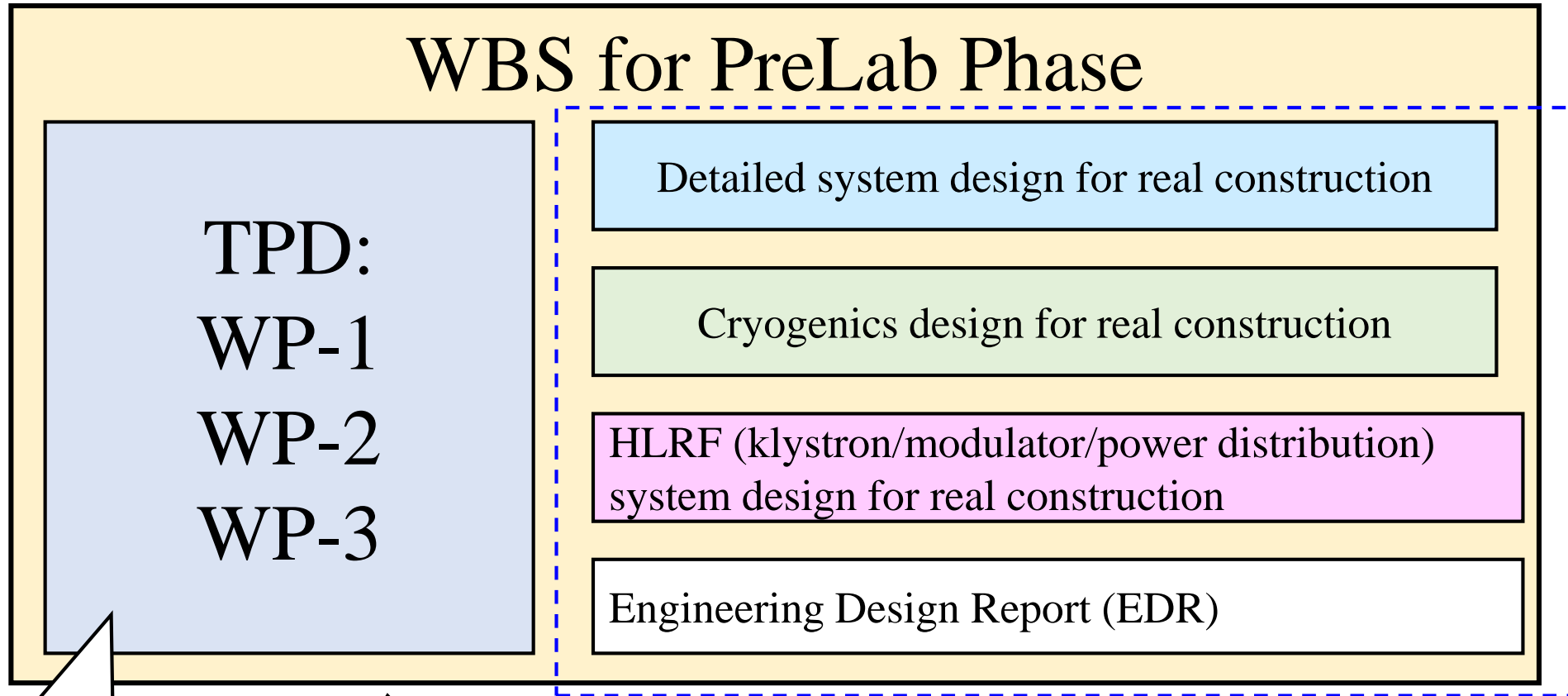

Already done!

Additional item:
650 MHz SRF system for DR?

Additional item:
5 GeV SC Booster Linac?

We may not need any cost,
but HR is necessary

Additional items (e^\pm booster linac) in WBS-SRF

4.3.6 The 5 GeV Superconducting Pre-Acceleration (Booster) Linac

Twenty-one standard ILC-type SC cryomodules accelerate the beam to 5 GeV and FODO cells integrated into the cryomodules transversely focus the beam. An additional string of three cryomodules is added to provide redundancy (total of 24 cryomodules). The booster linac consists of two sections. In the first section, the e^- beam is accelerated from 76 MeV to 1.7 GeV in cryomodules with one quadrupole per module. In the second section, the e^- beam is accelerated to the final 5 GeV in cryomodules with one quadrupole every other module.

5.3.4 5 GeV SC Booster Linac

It accelerates the beam from 400 MeV to 5 GeV using SC L-band RF modules. There are three sections with a periodic FODO lattice. The first low-energy section which accelerates up to 1083 MeV contains four cryomodules with six 9-cell cavities and six quadrupoles. The quadrupole field strength $(\partial B/\partial x) \times L$ varies from 0.8-2.4 T. The second section up to 2507 MeV uses six standard ILC-type cryomodules, each containing eight 9-cell cavities and two quadrupoles. The quad strength ranges from 0.6-1.4 T. The last section up to 5 GeV has twelve standard ILC-type cryomodules, each with eight 9-cell cavities and one quadrupole. The quadrupole field strength ranges from 0.8-1.7 T.

Additional items (650 MHz @DR) in WBS-SRF

6.6 RF systems

The damping-ring RF frequency of 650 MHz has a simple relationship with the main linac RF (1.3 GHz) to accommodate varying bunch patterns. While high-power 650 MHz RF sources are not commercially available, several klystron manufacturers can develop them by modifying 500 MHz klystrons of equivalent power level. Similarly, the RF cavity units can be designed by scaling from existing 500 MHz superconducting module designs currently in operation at CESR, KEK, [123–125] and elsewhere. New designs are required for the input coupler because the power handling capability must be kept at a level of about 300 kW CW, as well as for the HOM dampers and cryostats. The parameters presented in Table 6.6 are scaled from the 500 MHz units developed by industry and being operated in various laboratories. The RF-cryomodules are 3.5 m in length and 1.5 m in diameter.

Table 6.6
RF system parameters for the 3 different operating configurations [98].

Parameter	Unit	Nominal 5 Hz	10 Hz mode e ⁺ ring	Luminosity upgrade
Frequency	MHz		650	
Total RF voltage	MV	14	22	14
Overtoltage factor		2.94	2.49	2.94
Active cavity length	m		0.23	
R/Q	Ω		89	
Q_0 at operating gradient	10^9	1	0.6	1
Number of cavities/ring		10	12	12
Cavity RF voltage	MV	1.4	1.83	1.17
Cavity average gradient	MV/m	6.1	8.0	5.1
Beam power per cavity	kW	185.5	287	309
Input coupler Q_{ext}			68×10^3	
Cavity tuning		stationary	fixed	stationary
RF reflected power	%	8.0	11.4	2.6
HOM Power	%		5	
Total RF power	MW	2.00	3.83	3.80
Number of klystrons/ring		5	6	6
Klystron peak power (10% overhead)	kW	441	703	698
Operating temperature	K		4.5	
RF cryogenic losses per cavity	W	15	50	15
Number of SC modules per ring		10	12	12
Static cryo losses at 4.5 K	W		30	
Total cryo losses per ring	W	450	960	540

(modified) Table 2.12 in TDR Vol.3 Part I

Revised Table 2.12 "Various tuners investigated in the Technical Design Phase."

12/Apr/2021 Revised by Yuriy + Kirk

	(SLIM) Blade tuner [1]	Saclay/DESY tuner [2]	Slide-jack tuner [3]	Double-lever tuner [4]
Type	Coaxial	Lateral-Pick-up side	Coaxial and lateral coupler side	Lateral-Pick-up side
(fit to) Beampipes of TESLA Cavity	short-short, short-long	short-long	short-short, short-long	short-short, short-long
Cavity/Tuner system stiffness	30 kN/mm	30 kN/mm	290 70 kN/mm	40 kN/mm
Drive unit	Inside vessel	Inside vessel	Outside vessel	Inside vessel
	Stepper motor	Stepper motor	Stepper motor	Stepper motor
	Harmonic Drive	Harmonic Drive	both manual or stepper motor actuation	Planetary Gear Drive
Nominal frequency	1.3 GHz	1.3 GHz	1.3 GHz	1.3 GHz
Nominal tunable range	600 kHz	500 kHz	900 kHz	800 kHz
Nominal sensitivity	1.5 Hz/step	1 Hz/step	3 Hz/step	1.4 Hz/step
Coarse tuner hysteresis	<i>100Hz</i>	<i>100Hz</i>		<i>45Hz</i>
Piezo	2, thin-layer	2, thin-layer	1, thick-layer	2, thin-layer
	(0.1 mm), dim.	(0.1 mm), dim.	(2 mm), dim.	(0.1 mm), dim.
	10 x 10 x 40 mm ³	10 x 10 x 36 mm³	diameter 35 x 78 mm ²	10x 10 x 36 mm³
Piezo Voltage	200 V	120 V	1000 V, operated at 500 V	120 V
Nominal piezo stroke at R.T.	55 μm	40 μm	40 μm	40um
Nominal piezo capacitance at R.T.	8 μF	13 μF	0.9 μF	13 μF
Nominal tunable range (tested at 2K)	2,000 Hz	800 Hz	~600 Hz @500 V	3,000 Hz
Capability to repair (motor + piezo)	No	No	OK	OK
# of tuner operated in accelerators	8 @FNAL/FAST	800 @E-XFEL	14 @STF-2, Quantum Beam	320+180 @LCLS-II (HE)
# of tuner operated in S1-Global	2	2	4	

[1] <https://lss.fnal.gov/archive/2011/conf/fermilab-conf-11-101-td.pdf>

[2] [LLRF Tests of XFEL Cryomodules at AMTF: First Experimental Results \(cern.ch\)](#)

[3] [Cryomodule Tests of Four Tesla-Like Cavities in the STF Phass-1.0 for ILC \(cern.ch\)](#)

[4] <https://accelconf.web.cern.ch/IPAC2015/papers/wepty035.pdf>

Minor changes in task list for technical preparation

SRF

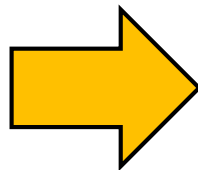

Main linac and SRF

※Based on TDR

- ◆ Cavity and cryomodule production
- ◆ Cryomodule transport (“Global CM transfer”)

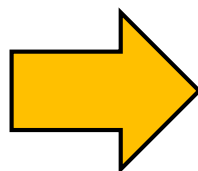

- ◆ Cavity Industrial-production Readiness
- ◆ Cryomodule transport and Performance assurance
- ◆ Crab Cavity
- ◆ Bunch compressor and others (not only SRF)
- ◆ Engineering design report

※Hub-lab. Infrastructure added in CM and crab

Reconfirmation of cost unit in ILC

- **ILCU** (ILC unit) has been used as the cost unit for ILC since GDE era
- Based on US dollars as of January 2012 (1 ILCU = \$1)

TDR Vol.3 II

15.4.2.4 ILCU Definition in terms of PPP Indices

For the TDR, the ILCU will be defined as equal to the USD on January 1, 2012. Conversions of estimates obtained in currencies other than USD to ILCU will be based on PPP indices (as of January 1, 2012) relating those currencies to the USD. The only exception to this rule is for the superconducting material for the cavities. There is only one supplier of RRR-niobium raw material in the world. Thus, it is appropriate to consider this cost element to be a commodity which must be purchased on the international market. In preparing the Value estimate, conversions from currencies other than USD to ILCU for this cost element have been based on exchange rates as of January, 2012. The PPP indices of four regional⁶ currencies, relative to the USD, together with exchange rates, are shown in Fig. 15.2. Numerical values of the PPP indices and exchange rates for January, 2012, which are used in the Value estimate, are given in Table 15.2.

Table 15.2. Currency conversion factors between ILCU and national currencies (January, 2012). To convert a cost element from ILCU to the indicated currency, multiply by the factor appropriate for the type of cost element.

Cost element type	ILCU→USD	ILCU→Euro	ILCU→Yen	ILCU→CHF
Civil construction (PPP)	1	0.939	109.3	1.303
Machinery and equipment (PPP)	1	0.923	127.3	1.480
Superconducting material (EX)	1	0.776	76.9	0.939

FTE-yr estimated in ILC Action Plan 2016

ML and SCRF has 224 (Japan) and 74 (abroad)

Appendix 5. Breakdown of the Human Resource Plan (see: Table 3 in the main text)

Category	Subject		pp	P1	P2	P3	P4	Int.-FTE
Grand-Sum		Sum =JP+Abr.		118 = 80+38	161 = 105+56	222 = 138+84	282 = 171+111	783 = 494+289
Acc-Sum		Sum =JP+Abr.		82 = 54+ 28	115 = 74+41	163 = 98+65	211 = 122+89	571 = 348+223
Accelerator (FTE)	Tech. coordination	JP abroad		1 2	1 2	1 2	1 2	4 8
	ADI	JP abroad		3 6	4 8	6 12	8 16	21 42
	SRF (& ML)	JP abroad		38 8	50 12	62 22	74 32	224 74
	Nanobeam (& DR, BDS)	JP abroad		6 6	9 9	15 15	21 21	51 51
	Sources (e-, e+)	JP abroad		3 3	4 4	5 5	6 6	18 18
	Others (RTML, Dump etc.)	JP abroad		3 3	6 6	9 9	12 12	30 30

KEK ILC Action Plan 2016

IDT-WG2 organization

Bi-weekly **Tuesday** meeting: Sep.22, Oct. 6, 20,...

IDT WG2
Shin Michizono (Chair)
Benno List (Deputy)

<https://agenda.linearcollider.org/category/256/>

SRF **Bi-weekly Tuesday**
Oct.13,27,...

DR/BDS/Dump **Bi-weekly Tuesday**
Oct.13,27,...

Yasuchika Yamamoto	KEK
Nuria Catalan	CERN
Enrico Cenni	CEA
Dimitri Delikaris	CERN
Rongli Geng	JLAB
Hitoshi Hayano	KEK
Bob Laxdal	Triumpf
Matthias Liepe	Cornell
Peter McIntosh	STFC
Laura Monaco	INFN Milano
Olivier Napoly	CEA
Sam Posen	FNAL
Robert Rimmer	JLAB
Marc C. Ross	SLAC
Luis Garcia Tabares	CIEMAT
Hans Weise	DESY
Akira Yamamoto	KEK

Toshiyuki Okugi	KEK
Karsten Buesser	DESY
Philip Burrows	U. Oxford
Angeles Faus-Golfe	LAL
Jenny List	DESY
Thomas Markiewicz	SLAC
Brett Parker	BNL
David L. Rubin	Cornell
Nikolay Solyak	FANL
Nobuhiro Terunuma	KEK
Glen White	SLAC
Kaoru Yokoya	KEK
Mikhail Zobov	INFN LNF

Ivan Podadera ivan.podadera@ciemat.es

Charges of Sub-groups

- Discuss and coordinate the topics for
 - technical preparation (remaining topics) at Pre-lab
 - preparation for mass production at Pre-lab
 - possible schedule at Pre-lab
 - international sharing candidates of these activities
- Report to the IDT-WG2

All members belong to some sub-group(s).

Sources **Bi-weekly Monday**
Oct.12,26,...

Kaoru Yokoya	KEK
Jim Clarke	STFC
Steffen Doebert	CERN
Joe Games	JLAB
Hitoshi Hayano	KEK
Masao Kuriki	U. Hiroshima
Benno List	DESY
Gudrid Moortgat-Pick	U. Hamburg

Peter Sievers Peter.Sievers@cern.ch

Sabine Riemann<sabine.riemann@desy.de>

Civil engineering

Nobuhiro Terunuma	KEK
John Andrew Osborne	CERN
Tomoyuki Sanuki	U. Tohoku

2pm UTC (6am US Pacific, 8am US Central, 2pm U.K., 3pm Geneva, 11pm Japan)

Main tasks in technical preparation period based on “Recommendations on ILC Project Implementation”

- ◆ Cavity and cryomodule production
 - ◆ 100 cavities produced in preparation for mass production
 - ◆ ~1% of full production
 - ◆ Japan: 50 cavities, other regions/countries: 50 cavities
 - ◆ By new cost-effective production method
 - ◆ Plug-compatibility re-confirmed/re-established
 - ◆ Surface preparation recipe baseline/guideline to be re-established
 - ◆ To be checked RF performance/success yield
 - ◆ High pressure gas regulation in Japan (cavity/cryomodule production)
 - ◆ Coupler/Tuner improved/produced/assembled/tested
 - ◆ Superconducting magnet (quad.+dipole combined) in CM to sustain under dark current irradiation from high-gradient SRF linac
 - ◆ Cryomodule (CM) production/test
- ◆ Cryomodule transport (“Global Cryomodule transfer”)
 - ◆ Shipment/transport incl. inspection
 - ◆ RF performance rechecked after transport

Crab cavity is listed additionally **as third issue**

Update of # of cavity/cryomodule produced in technical preparation period

Before this production starts, tuner design should be fixed!!

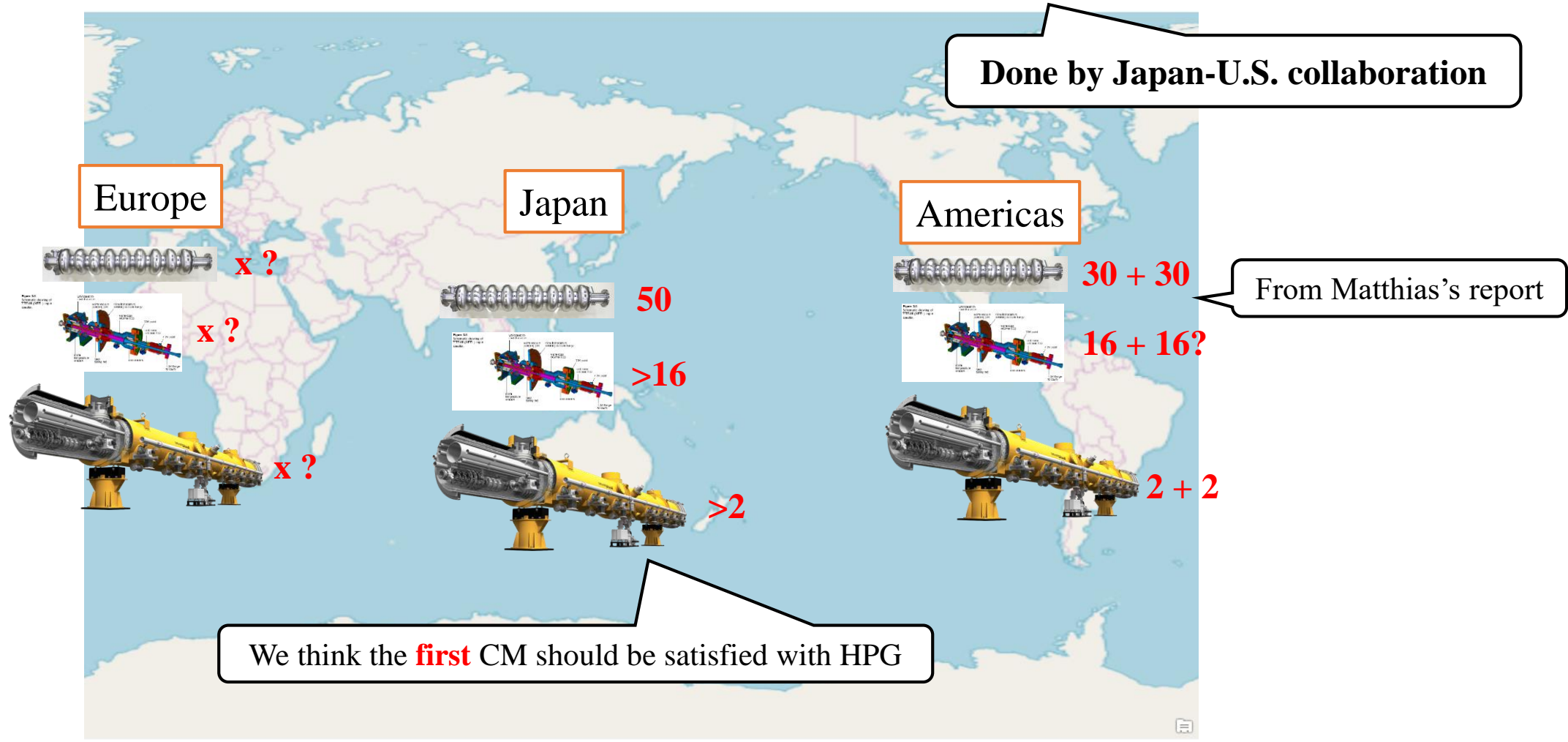

In the both plans of Japan and Americas, upgrade of infrastructure as function of hub-laboratory is also included!

Interface and Process established, in TDR, 2013

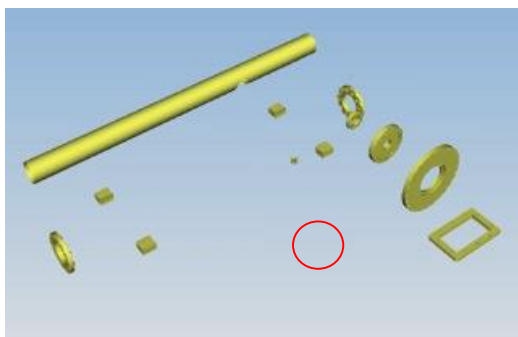
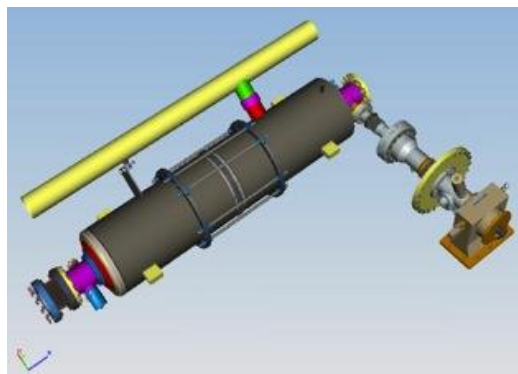

Item	TDR Baseline
Cavity shape	TESLA
Length	Fixed, L = 1,247 mm (61 mm shorter than XFEL)
Beam pipe flange	Fixed
Suspension pitch	Fixed
Tuner	Blade
Coupler flange (cold end)	40 mm
Coupler pitch	Fixed
He -in-line joint	Fixed

	Standard Fabrication/Process
Fabrication	Nb-sheet purchasing
	Component Fabrication
	Cavity manufacturing with EBW
Process	EP-1 (~150um)
	Ultrasonic degreasing with detergent, or ethanol rinse
	High-pressure pure-water rinsing
	Hydrogen degassing at > 600 C
	Field flatness tuning
	EP-2 (~20um)
	Ultrasonic degreasing or ethanol (or EP 5 um with fresh acid)
	High-pressure pure-water rinsing (HPR)
	Antenna Assembly
	Baking at 120 C
Cold Test (vertical test)	Performance Test with temperature and mode measurement

12/05/14 KEK-LC-Meeting

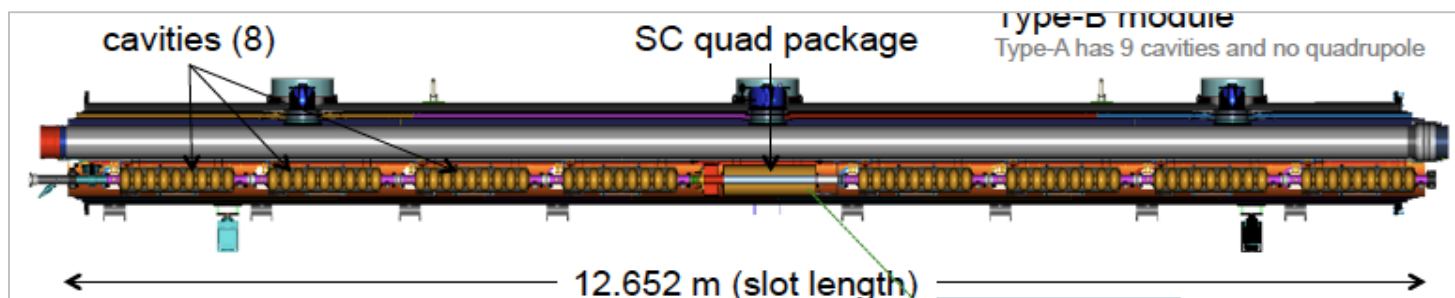
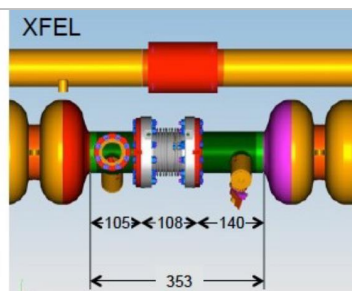
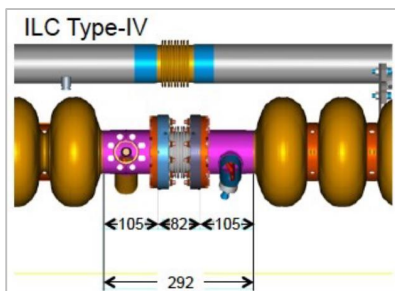

Global cryomodule transfer in technical preparation period

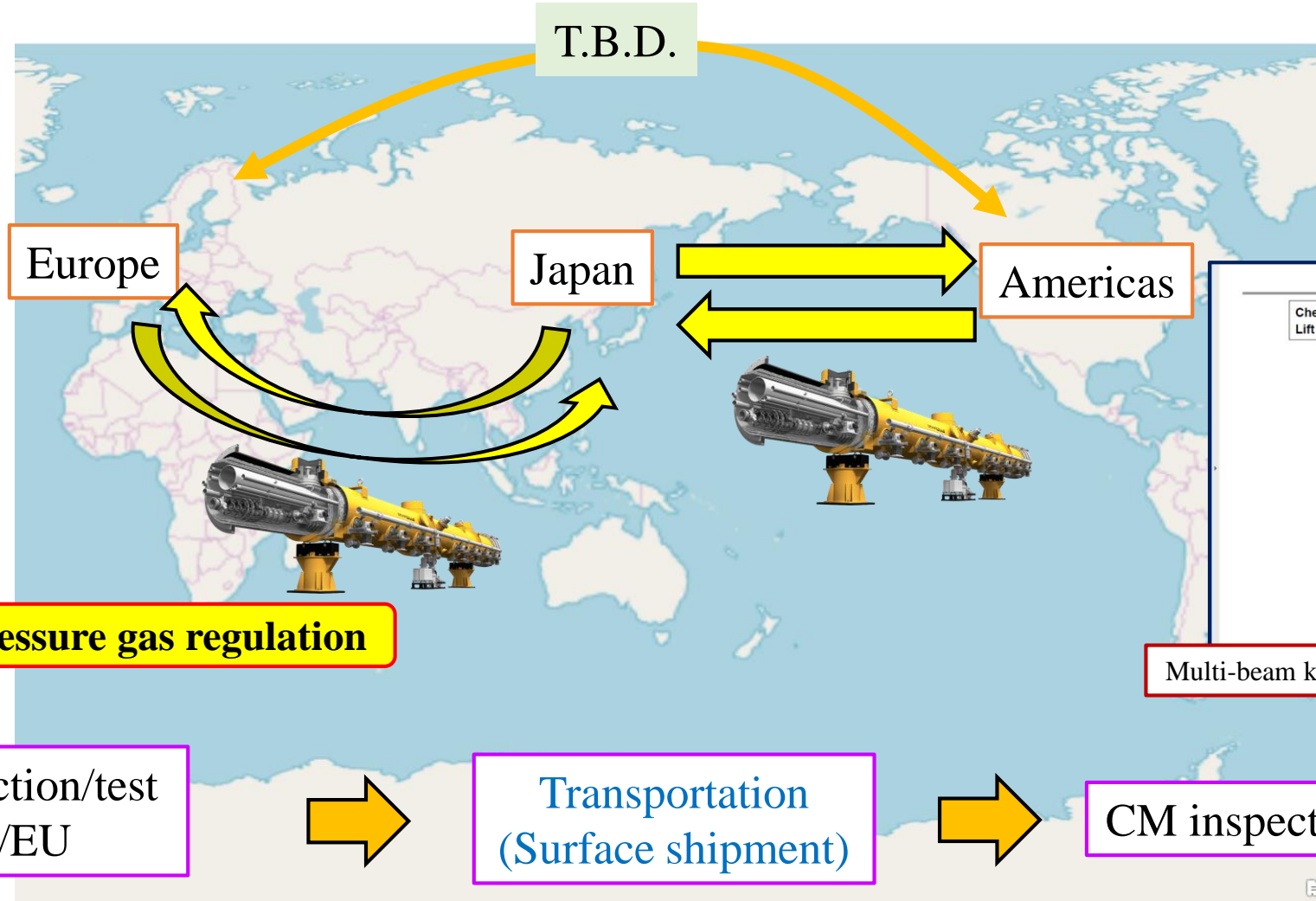

Preparation for task list/budget request

Michizono-san and Kirk are preparing for document and task list including budget request for the technical preparation period. We will submit the preliminary version to EB early December. Then, the SRF subgroup has to fix the task list until the end of this month.

Table 4.3: Accelerator-related technical preparation tasks and possible partners for international collaboration as envisioned by KEK.

Component	Issue	Summary of tasks	Candidates for collaboration
SCRF Cavity	Mass production incl. automation	Performance statistics, mass production technology	France, Germany, US
	Cryomodule transport	Performance assurance after transport	France, Germany, US
Rotating target	Design	Exchanging target, design	CERN, France, Germany, US + industry-academia efforts
	Design	Design	France, Germany, Russia
Ring	Design	Design	CERN, Germany
	Feedback	Test at SuperKEKB	CERN, Italy
Interaction	Beam	Long-term stability, design	CERN, Italy
	Beam	Test at SuperKEKB	CERN, UK
Beam Dump	Beam window, cooling water circulation	Durability, exchangeability, earthquake-resistance	CERN, US + industry-academia efforts

Budget request will be added

Name of laboratories will be added

Component	Issue	Task	Candidates
CM SCQ(+D)	Sustainability against SRF dark current	Absorb heating and not causing quench	US and Spain
Tuner	Design not fixed	Reconfirmation Wider range piezo	Japan and US

Crab cavity is listed additionally **as third issue**

If you don't have any other input, we can fix these two (plus one) tasks as the list of SRF

High pressure gas regulation and schedule of cavity/CM production

Regarding high pressure gas (HPG) regulation, KEK is currently trying to launch a task force.

Recently, **cavities and cryomodule components produced in Europe have been delivered to Rokkasho for IFMIF project.**

After the delivery, every part including cavity string is assembled at Rokkasho (under progress).

I think we can learn a lot from this experience.

Mr. Kasugai replied that he may provide his presentation reviewing his effort for IFMIF, and possibly at LCWS2021.

We will have a first meeting about HPG between KEK and QST on 25/Nov.

As a proposal, since it is **impossible to manufacture cavities compatible with HPG in the first year of the technical preparation period**, we will **manufacture 10 cavities that are not compatible only in the first year**. If we decide to manufacture a cavity compatible with HPG from the next fiscal year and later, it will open the way for the ILC to be **used as spare cavities**, which will be an effective utilization measure.

For construction of CM, we think that the "global transfer" cryomodule program shall start from the beginning of the technical preparation period, in order to properly satisfy the HPG regulation process in Japan.

There are two different types of rules (general rule and cryoplant rule (cryo-plant in refrigeration mode with closed gas-flow circuit)) in HPG in Japan. We think cryoplant rule is preferable for ILC.

It is necessary to discuss/consider this matter more with many experts.

Linac and CM in IFMIF
(courtesy of Kasugai-san)

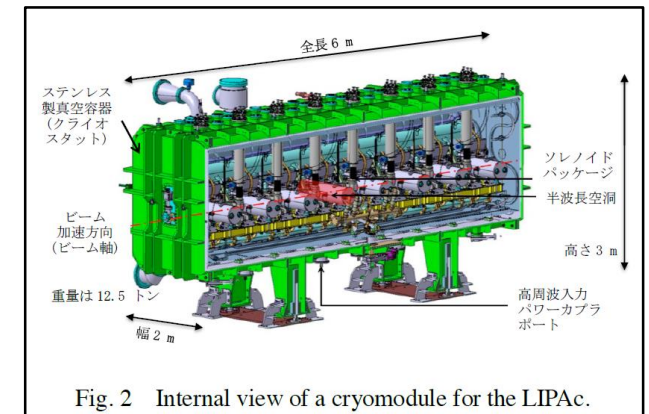
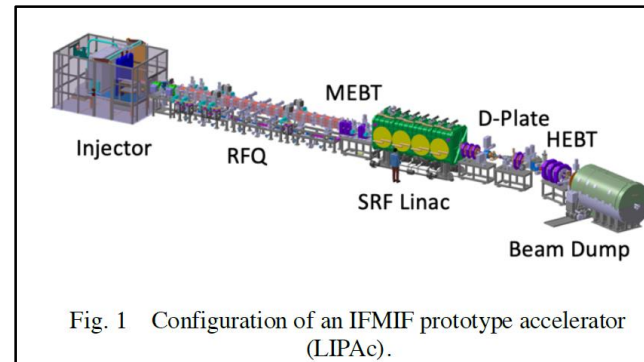

Brief view of High-Pressure Gas Regulation

◆ Step 1 (discussion)

- ◆ Before cavity/CM production, we need to discuss with KHK (authority of KRISS in Japan)
- ◆ KHK requests to submit necessary documentations (material certificate, EBW method, simulation results related to mainly mechanical crush, etc.)
- ◆ KHK may request Charpy impact test for Nb material
- ◆ KHK may request TIG welding test between electrode and helium tank

◆ Step 2 (production)

- ◆ Cavity/Cryomodule production satisfying high pressure gas regulation
- ◆ KHK may stand by during production

◆ Step 3 (inspection)

- ◆ Must undergo completion inspection for cavity

These issues will be drastically changed in case of RS ordinance!

Required number of cavities, and performance improvement by recent surface treatment for ILC

Recently, some ideas for improving cavity performance (mainly Q_0 value) have been tested.

Even if these attempts of cost down R&D are successful, we will **not reduce the number of cavities required for the ILC-250** presented after TDR.

The performance improvement achieved after TDR is considered as an additional **margin (insurance)**.

And, it will be positioned as a technology for more efficient and appropriate upgrades in the future.

The performance of the cavities manufactured during the preparation period shall also satisfy the specifications of TDR.

Further, for the purpose of improving the cavity performance, the number of recent surface treatments has been increasing, but it is also a factor of cost increase.

In the first place, it is necessary to consider cost effective improvement while maintaining the spirit of cost reduction.

The selection of niobium material and surface treatment method can be finally selected in each country or each laboratory.

Similarly, it is necessary to agree that each country or each laboratory is responsible for the cost increase associated with it.

We plan to **hold a session at LCWS2021 (around spring in 2021) to discuss cost reduction R&D, and which is the best method.** Probably also in TTC meeting 2021.

Accelerator activities at ILC Pre-lab phase

Presented by S. Michizono in IDT-EB meeting

Technical preparations /performance & cost R&D [shared across regions]

- **SRF** performance R&D, quality testing of a large number of cavities (~100), fabrication and shipping of cryomodules from North America and Europe (for validating shipping)
- **Positron source** final design and verification
- **Nanobeams (ATF3 and related)**: Interaction region: beam focus, control; and Damping ring: fast kicker, feedback
- **Beam dump**: system design, beam window, cooling water circulation
- Other technical developments considered performance critical

Technical preparation

Final technical design and documentation [central project office in Japan and possibly regional project offices]

- **Engineering design** and documentation, WBS
- **Cost confirmation/estimates**, tender and purchase preparation, transport planning, mass-production planning and QA plans, schedule follow up and construction schedule preparation
- Site planning including environmental studies, CE, safety and infrastructure (see below for details)
- Review office
- Resource follow up and planning (including human resources)

Engineering Design Report (EDR)

Preparation and planning of deliverables [distributed across regions, liaising with the central project office and/or its satellites]

- Prototyping and qualification in local industries and laboratories, from SRF production lines to individual WBS items
- Local infrastructure development including preparation for the construction phase (including Hub.Lab)
- Financial follow up, planning and strategies for these activities

Planning and preparation of Hub lab.

Civil engineering, local infrastructure and site [host country assisted by selected partners]

- Engineering design including cost confirmation/estimate
- Environmental impact assessment and land access
- Specification update of the underground areas including the experimental hall
- Specification update for the surface building for technical scientific and administrative needs

Civil engineering

For Engineering design

- 1st year:** Work on TDR-based **cost-estimate confirmation**, started by an international team centered on the Pre-lab.
- 2nd year:** Complete the cost-estimate confirmation, and an **internal review** in the latter half of the 2nd year.
The review also reports on the progress of technical issues during the preparation period.
- 3rd year:** Conduct an **external review** and completed scrutiny of costs and risks.
Complete the **draft of Engineering Design Report (EDR)**.
- 4th year:** Publish **EDR (in first half yr)**, report progress on technical issues, and prepare each large bid.

For technical preparation (example of SCRF and positron)

- 1st year:** Extend SCRF cost reduction R&D, Start a pre-series SCRF cavities production preparing for industrialization
Continue positron survey
- 2nd year:** Complete SCRF cost-reduction R&D, and extend the work to assemble the cavities with cryomodule (CM),
Select positron scheme
- 3rd year:** **Demonstrate “Global** CM transfer, aiming at HPG legal-process, shipment, and SRF QA test after transport
Mature Lab. planning and preparation
Prototyping of critical items (such as positron target)
- 4th year:** Evaluate CM performance based on CM shipment, and prepare for Hub Lab. functioning
Progress prototyping of critical items (such as positron target)

Kick-off meeting for crab cavity

- ◆ Crab cavity system is essential for ILC
- ◆ No progress after TDR
- ◆ **Prototype CM is necessary** (Nomura Research Institute, Ltd. considered not-matured technology)
- ◆ **Kick-off meeting will be held 30 min earlier before next SRF subgroup meeting on 24/Nov**
- ◆ Expected attendees: SRF subgroup, BDS subgroup, UK members related to crab cavity R&D in TDR, Crab cavity members for HL-LHC (?)
- ◆ Discussion items: Work list in technical preparation period, Cavity design, Responsible laboratories, etc.

For higher luminosity

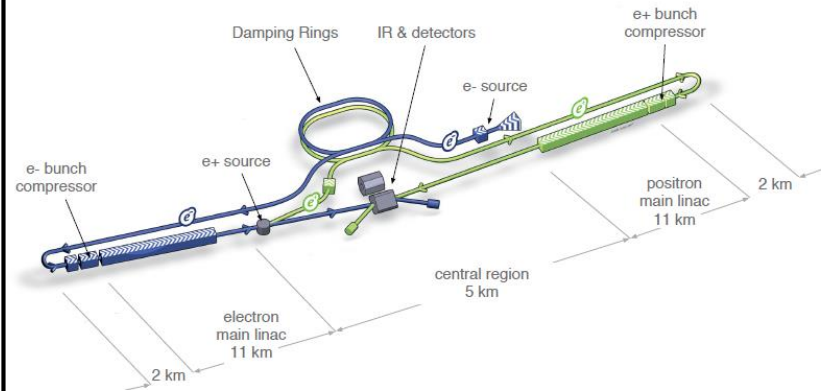

ILC RDR parameter, by CAIN simulation

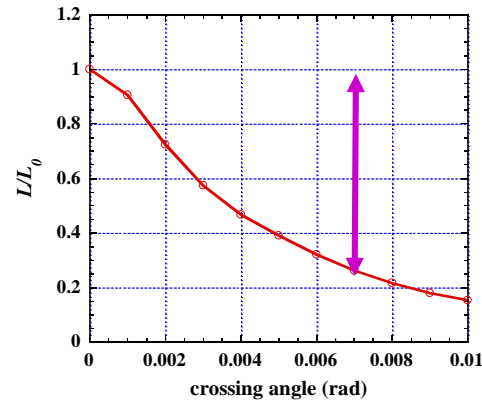

Cavity design presented in TDR

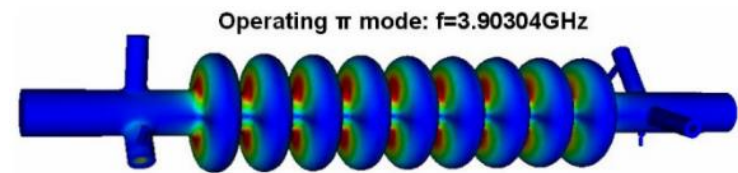

Not using crab cavities reduces luminosity by **80%!**

Pre-Lab schedule (translated into table)

	Technical preparation period (Fiscal year)			
Items	1	2	3	4
Cost down R&D	→			
Cost estimation based on TDR	→			
Review			External	
Engineering design report	→		Draft	Publish
Prototyping of critical items			→	
Preparation for mass-production technology			→	

These schedules are under discussions!

We have to fit the SRF schedule to this overall schedule!

Brief view of cavity production by cost-effective method, and the best recipe

◆ Step 1 (production)

- ◆ Cavity production by cost-effective method incl. selection of Nb material
- ◆ Reconfirmation of plug-compatibility (only flanges)
- ◆ Not necessary for satisfying high pressure gas regulation of Japan
- ◆ Not necessary for helium tank

Technical workshop is necessary

◆ Step 2 (decision of surface/heat treatment methods)

- ◆ Cold temp. EP or standard EP?
- ◆ N-dope, N-inf, Low temp. baking, Mid temp. baking, etc.?

Technical workshop is necessary

◆ Step 3 (RF performance check)

- ◆ VT1, but if not successful, VT2 done (after VT3, to be discussed)

◆ Step 4 (success yield)

- ◆ Estimate success yield for 1st pass and 2nd pass (after 3rd pass, to be discussed)

How many cavities are produced for mass production?

Discussion item

We can refer Volume 3 Part 1 in TDR.

At that time, **16** 9-cell cavities (out of > 50 cavities, **recognized as identical in fabrication and surface process**) were used to evaluate cavity performance.

In the preparation phase, **at least ~ 20 or much more cavities are necessary** to evaluate recent surface treatment method including fabrication method much advanced since TDR.

Not only surface treatment method but also what type of Nb material/fabrication method is used has to be discussed.

<p>Table 2.6 Processing and handling of high-purity niobium cavities</p>	<p>Light BCP etching (10 μm) Heavy EP (100-120 μm) Post-heavy-EP cleaning Vacuum-furnace outgassing (800 °C for 2 h) RF tuning by no-touch bead-pull Light EP (25 μm) Post-light-EP cleaning First HPR 3 passes (~ 6 h) First clean room assembly Final HPR 3 passes (~ 6 h) Final clean-room assembly Leak checking In-situ baking at 120 °C for 48 h</p>
---	--

Treatment method in TDR

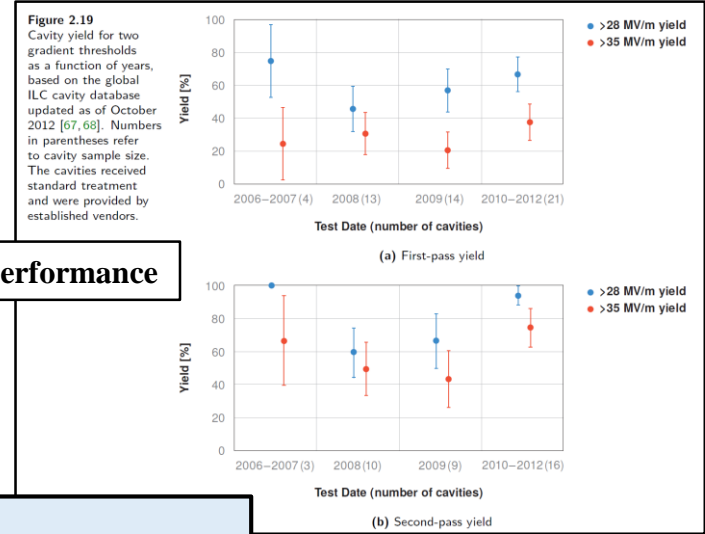

History of cavity performance

When we evaluate success yield of cavity performance, each region/lab. has to select one method of fabrication and surface process. But, we don't need world-unified method of fabrication and surface process.

Helium tank/tuner are not necessary for this evaluation

# of cavities	Japan (/Asia)	Americas	Europe
w/o helium tank/tuner	20	20	20
w/ helium tank/tuner			

At least 20 cavities are produced

Brief view of “Global CM transfer”

- ◆ Step 1 (production)
 - ◆ Cavity/Cryomodule production satisfying high pressure gas regulation
- ◆ Step 2 (performance check)
 - ◆ Checking RF performance and success yield in each region
- ◆ Step 3 (transport)
 - ◆ Designing/developing cage and shock damper
 - ◆ Inspecting vacuum pressure and mechanical damage after transport
- ◆ Step 4 (performance re-check)
 - ◆ Re-checking RF performance and success yield in Japan (maybe in others)

How many cryomodules are produced for mass production?

ILC needs two types of cryomodules; Type A and Type B.

Any laboratory has never produced same types of CM as ILC.

High pressure gas regulation of Japan should be also satisfied for ILC.

As first step, each region produces **one prototype CM** (not necessary for conforming high pressure gas regulation).

Type B is preferred, as it includes systems of SC-Q magnet/cold BPM. Prototype CM is produced and tested in each region.

As second step, each region produces **at least one CM conforming high pressure gas regulation of Japan**.

That CM (Type B is preferred) is produced and tested in each region. If possible, Type A can be also produced.

As final step, each region carries out **global CM transfer to Japan**. CM produced in second step is available.

Discussion item

Table 3.1
Summary of key numbers for the SCRF Main Linacs for 500 GeV centre-of-mass-energy operation. Where parameters for positron and electron linacs differ, the electron parameters are given in parenthesis.

<i>Cavity (nine-cell TESLA elliptical shape)</i>		
Average accelerating gradient	31.5	MV/m
Quality factor Q_0	10^{10}	
Effective length	1.038	m
R/Q	1036	Ω
Accepted operational gradient spread	$\pm 20\%$	
<i>Cryomodule</i>		
Total slot length	12.652	m
Type A	9 cavities	
Type B	8 cavities	1 SC quad package
<i>ML unit (half FODO cell)</i>		
(Type A - Type B - Type A)	282 (285)	units
<i>Total component counts</i>		
Cryomodule Type A	564 (570)	
Cryomodule Type B	282 (285)	
Nine-cell cavities	7332 (7410)	
SC quadrupole package	282 (285)	
Total linac length – flat top.	11027 (11141)	m
Total linac length – mountain top.	11072 (11188)	m
Effective average accelerating gradient	21.3	MV/m
<i>RF requirements (for average gradient)</i>		
Beam current	5.8	mA
beam (peak) power per cavity	190	kW
Matched loaded Q (Q_L)	5.4×10^6	
Cavity fill time	924	μs
Beam pulse length	727	μs
Total RF pulse length	1650	μs
RF-beam power efficiency	44%	

# of cavities/couplers/CMs	Japan (/Asia)	Americas	Europe
Cavity	16 + spare	16 + spare	16 + spare
Power coupler	16 + spare	16 + spare	16 + spare
Cryomodule	2	2	2

Brief report of KEK-DOE meeting

- The meeting done at 7:00~8:22 on 27/Oct (JST)
- Organized by A. Lankford
- 35 people attended
 - Japan: S. Michizono, A. Yamamoto, K. Yokoya, N. Terunuma, Kirk
 - Members of SRF subgroup in Americas: R. Rimmer, M. Liepe, R. Laxdal, R. Geng, S. Posen
- Michizono-san presented ILC overview, IDT, technical preparation, budget request from KEK, Recommendations on ILC Project Implementation, SCRF, positron source, damping ring, final focus system, beam dump, potential US accelerator contribution, and so on.
- A lot of discussions/questions/comments

Brief report of SRF session in AWLC2020

- ❑ 20 impressive presentations incl. three large-scale operating/on-going projects
- ❑ Presentation time was too short! Necessary to be considered in next LCWS
- ❑ Each topic:
 - ❑ E-XFEL by Nick; Four degraded cavities during operation, Stable RF availability, Piezo has impact on beam dynamics
 - ❑ LCLS-II-HE by Mattia; 2/0 doping was chosen as standard recipe, Cold temperature ($<13^{\circ}\text{C}$) EP used, Higher Q_0/E_{acc} than LCLS-II was already achieved in CM test
 - ❑ PIP-II by Genfa; Two CMs (HWR and SSR1) constructed/tested and testing, common design of 325/650 MHz CMs
 - ❑ Tuner by Yuriy; LCLS-II tuner is strong candidate for to ILC (no design changes required), piezo study is necessary
 - ❑ Power coupler by Denis; 776 couplers operated stably, 4 couplers had no conditioning and overheating, Much higher power operation is necessary for ILC
 - ❑ Robotics by Stephane; Robotics study is under progress using ESS cavities, Goes to assembly of flange/coupler in future

Mission of SRF subgroup in IDT/WG2

- ◆ List work items in ILC preparation period
 - ◆ Plug-compatibility of design to be re-confirmed/re-established
 - ◆ Mass production
 - ◆ Global CM transfer
 - ◆ Any other?
- ◆ List technical concerns (if any)
 - ◆ Although E-XFEL has been successfully constructed and operated (and LCLS-II also in progress), are there any concerns for ILC to be constructed in Japan?
 - ◆ High pressure gas (HPG) regulation to be globally handled
 - ◆ In Japan, IFMIF (@Rokkasho) requested CM construction to EU (satisfied with HPG regulation)
 - ◆ Contents specialized in Japan?
- ◆ List human resources/budget/schedule for each work item and in each region/lab.
 - ◆ Necessary to discuss how to share each work item for each region/lab.

Pre-lab schedule

1st year: TDR-based **estimate confirmation** work started by an international team centered on the Pre-lab.

2nd year: Estimate tabulation work, **internal review** in the latter half of the 2nd year. The review also reports on the progress of technical issues during the preparation period.

3rd year: Conducted an **external review** and completed scrutiny of costs and risks (this is the end of incorporating cost reduction R & D). Completion of **draft of engineering design report (EDR)**. **Prototyping** of critical items. Preparing **mass-production line**.

4th year: **EDR publishing (first half)**, report on progress on technical issues, preparation work for each large bid. **Prototyping** of critical items. Preparing **mass-production line**.

IDT WG2 timeline



Example (towards Pre-lab)

- 2022 April: Pre-Lab starts
- 2021 Dec.: IDT ends
- 2021 Feb.: First draft of budget request (each region/lab.)
- 2020 Dec.: Draft of sharing remaining technical preparation/pre-lab preparation (each region/lab.)
- 2020 Oct.: AWLC
- 2020 Oct.: Information sharing about **technical preparation and updating the list**
- 2020 Sep.: List of Pre-lab acc. activities/ **Human resources/ budget/** schedule

**2021, Submission of budget request in each region/lab,
(2021, early Summer: Submission of budget request to MEXT, in case of Japan)**

Materials for Pre-lab human resources, budget, technical preparation

- KEK ILC action plan (Jan. 2018, KEK)

https://www.kek.jp/en/newsroom/KEK-ILC_ActionPlan_Addendum-EN%20%281%29.pdf

- “Recommendations on ILC Project Implementation” (Oct. 2019, KEK)

<https://www.kek.jp/en/newsroom/2019/10/02/1000/>

* Both materials are based on KEK estimate.

Progress of High-Pressure Gas Safety Act in Japan

- Two categories in Japan (see next slide by Nakai-san)
 - General High-Pressure Gas Safety (General HPGS) Ordinance (Regulations)
 - Refrigeration Safety (RS) Ordinance
- Current status of KEK as follows (due to historical reason since 1970's)
 - SC Magnet systems have (mostly) moved to the RS Ordinance
 - SC Cavity (SRF) systems have (mostly) stayed at the General HPGS Ordinance
- Recent advances in new SRF cavity/CM projects in Japan, as follows
 - RILAC SRF cavities @RIKEN with the RS Ordinance → in operation since 2020
 - IFMIF SRF cavities @QST with RS Ordinance → under construction

We are considering **“Refrigeration Safety Ordinance” is suitable for ILC**, instead of “General High Pressure Gas Safety Ordinance”!
(See more explanation following)

General and Refrigeration Ordinances

- * General High Pressure Gas Safety Ordinance
 - * Open-loop system (liquified helium can be taken out)
 - * Safety inspection and periodical self inspection (once a year each) required (inspections performed alternately every half year)
 - * Supervisory safety workers on duty during operation
- * Refrigeration Safety Ordinance
 - * Closed-loop system (no gas escaped even if system stopped abnormally)
 - * No supervisory safety worker necessary during operation
 - * Only periodical self inspection required once a year (safety inspection exempted for helium refrigerators)

Schematic view of STF/COI in KEK (Current Status/Plan)

STF
(ground level)

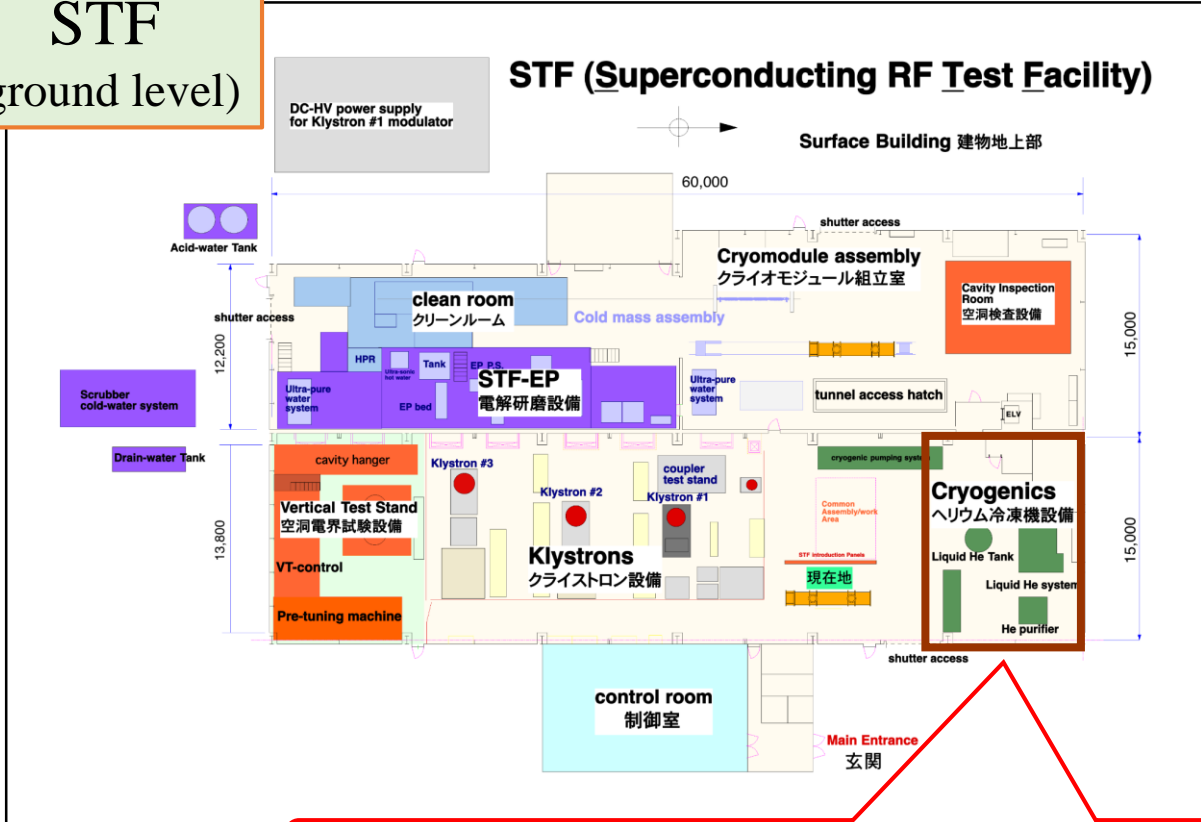

General High Pressure Gas Safety Ordinance

COI

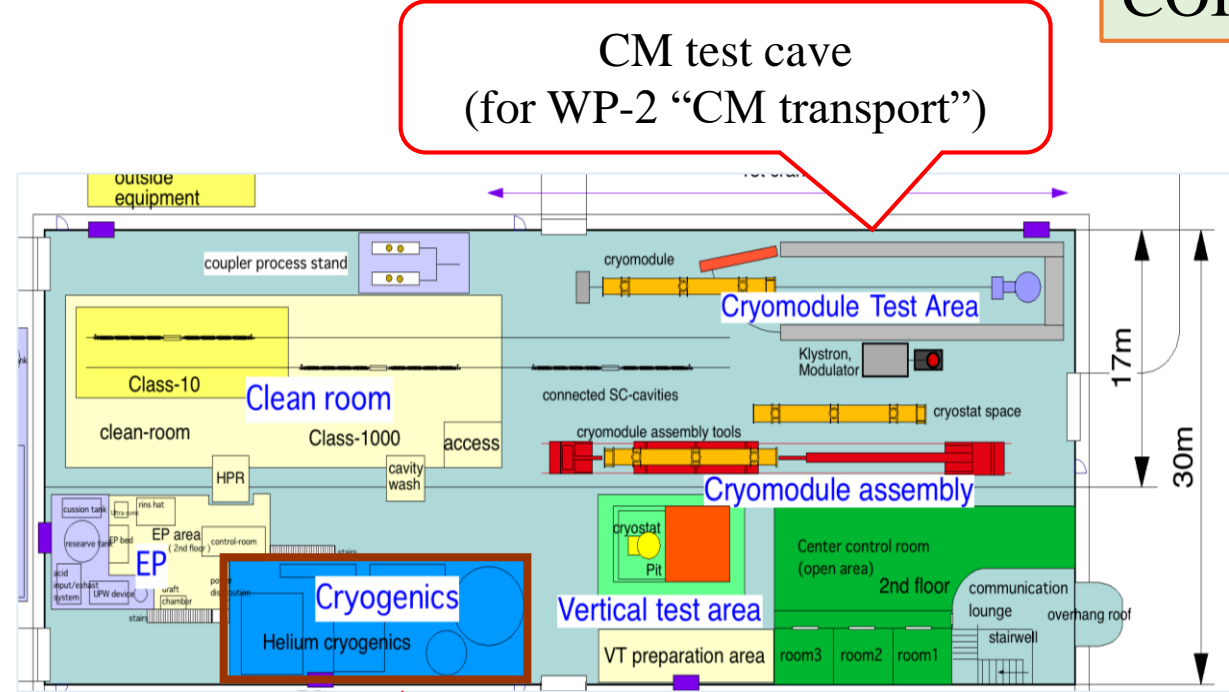

General High Pressure Gas Safety Ordinance, currently, and a possibility to convert to Refrigeration Safety Ordinance to be investigated.

STF
(tunnel)

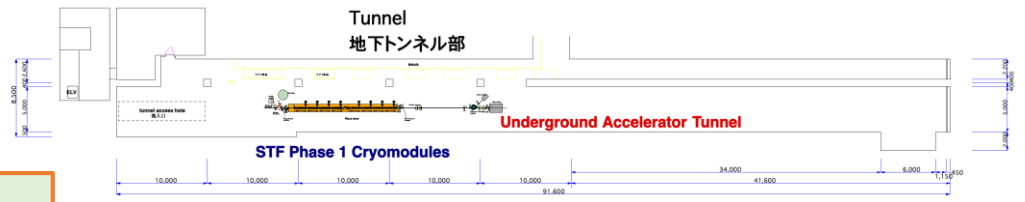

In case of Japan (KEK)...

STF



Demonstration of beam acceleration satisfied with ILC spec.

Infrastructure upgrade for hub-lab. is mandatory!

COI



Mass production of CM

CFF



Mass production of cavity

Contribution from each lab. (case of E-JADE)

Kirk will make template table after discussion with Michizono-san and Akira Yamamoto-sensei. Please wait a minute!

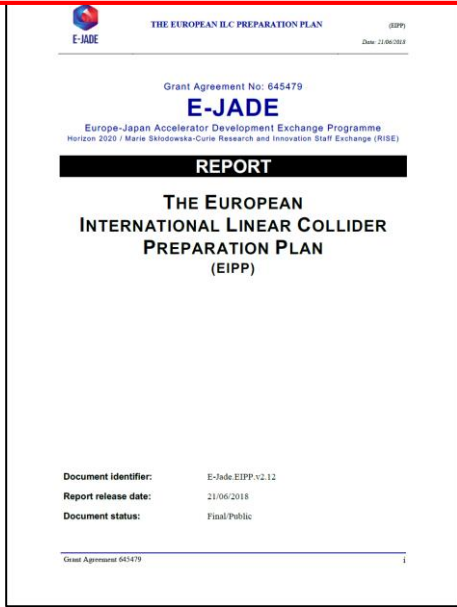

Item/topic	Brief description	CERN	France C	Germany E	Time line
SCRF	Cavity fabrication including forming and EBW technology,	✓			2017-18
	Cavity surface process: High-Q & -G with N-infusion to be demonstrated with statics, using High-G cavities available (# > 10) and fundamental surface research		✓	✓	2017-18
	Power input-coupler: plug compatible coupler with new ceramic window requiring no-coating	✓			2017-19
	Tuner: Cost-effective tuner w/ lever-arm tuner design	✓	✓		2017-19
	Cavity-string assembly: clean robotic-work for QA/QC.		✓		2017-19
Cryogenics	Design study: optimum layout, emergency/failure mode analysis, He inventory, and cryogenics safety management.	✓			2017-18
HLRF	Klystron: high-efficiency in both RF power and solenoid using HTS	✓			2017- (longer)
CFS	Civil engineering and layout optimization, including Tunnel Optimization Tool (TOT) development, and general safety management.	✓			2017-18
Beam dump	18 MW main beam dump: design study and R&D to seek for an optimum and reliable system including robotic work	✓			2017- (longer)
Positron source	Targetry simulation through undulator driven approach			✓	2017-19
Rad. safety	Radiation safety and control reflected to the tunnel/wall design	✓			2017 - (longer)

- SRF sub-groups need to make similar table for each region (Asia, America).
- Addition to these items, some new contents need to be added to the table.
 - CM transportation, automation, etc.
- And, budget, human resources...

Table 1: Current common studies between European institutions and Japan relevant for ILC.

KEK starts development of automation technique

	Germany DESY	France CEA Saclay	LAL	Italy INFN Milan	IFJ PAN	Poland WUT	NCBJ	Russia BINP	Spain CIEMAT
Linac									
Cryomodules	✓	✓		✓					
SCRF Cavities	✓			✓					
Power Couplers	✓		✓						
HOM Couplers							✓		
Frequency Tuners	✓								
Cold Vacuum	✓							✓	
Cavity String Assembly	✓	✓							
SC Magnets	✓				✓				✓
Infrastructure									
AMTF	✓				✓			✓	
Cryogenics	✓								
Sites & Buildings									
AMTF hall	✓								

	Germany DESY	France CEA	IPNO	Italy Elettra	INFN-LASA	Poland IFJ-PAN	Spain ESS Bilbao	Sweden ESS	Uppsala	UK STFC
RF systems				✓			✓	✓		
LLRF									✓	
Cryomodules		✓	✓							
SCRF Cavities		✓	✓		✓					✓
Power Couplers		✓	✓							
HOM couplers										
Frequency Tuners		✓	✓							
Cold Vacuum		✓	✓					✓		
Cavity String Assembly		✓	✓							
RF Tests (Cavities)	✓									✓
RF Tests (Cryomodules)		✓	✓			✓		✓	✓	

Table 2: Responsibility matrix for cryomodule production and testing for the European XFE

Table 3: Responsibility matrix for the cryomodule production and testing for the ESS.

Length difference between TESLA and ILC cavities

XFEL TESLA-Cavity

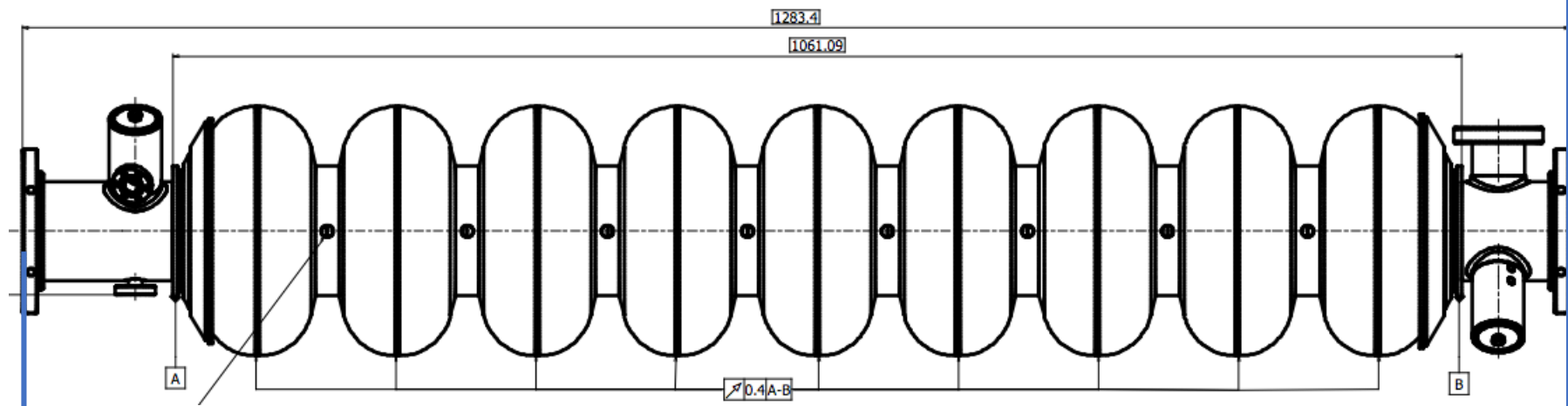

ILC-Cavity

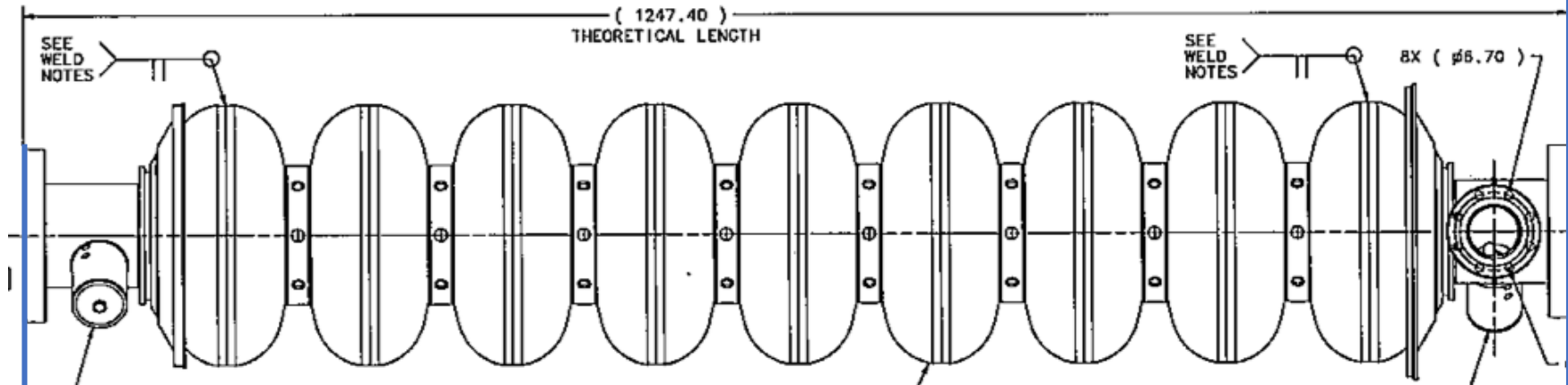

36mm



H. Hayano

Table 3.8 in TDR Vol.3 Part II

Results in STF-2

Table 3.8
Main specifications of the frequency tuner.

Tuner	Parameter	Specifications
Slow tuner	Tuning range	> 600 kHz
	Hysteresis	< 10 μ m
	Motor characteristics	Step motor, power-off holding, magnetically shielded
	Motor location	Inside 5K shield, accessible from outside
	Magnetic shield	< 20mG
	Heat load by motor	< 50 mW at 2 K
	Motor lifetime	> 20 \times 10 ⁶ steps
Fast tuner	Tuning range	>1KHz at 2K
	LFD residuals	< 50 Hz at 31.5 MV/m flat-top
	Actuator	Piezo actuator, located inside 5K shield, Two actuators for redundancy
	Heat load by actuator	< 50 mW at 2 K
	Magnetic shield	< 20mG
	Actuator lifetime	> 10 ¹⁰ pulses

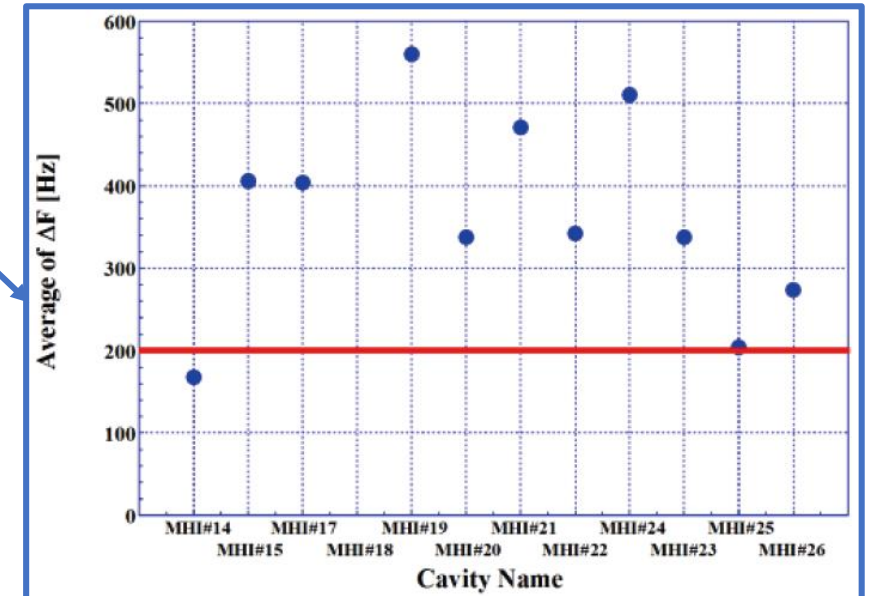
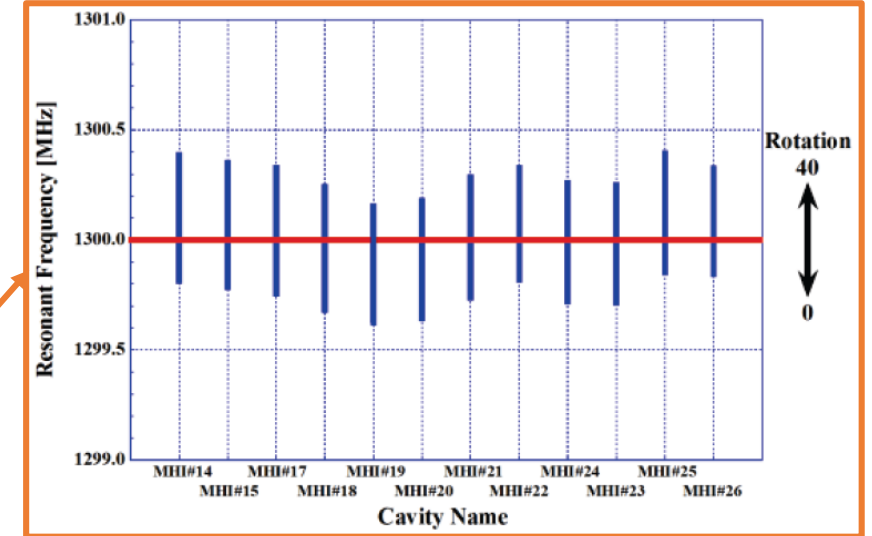

Table 2.12 in TDR Vol.3 Part I

Table 2.12
Various tuners investigated in the Technical Design Phase.

	Blade tuner	Saclay/DESY tuner	Slide-jack tuner
Type	Coaxial	Lateral-Pick-up side	Coaxial and lateral coupler side
Tuner stiffness (design)	30 kN/mm	40 kN/mm	290 kN/mm
Drive unit	Inside vessel, Stepper motor + Harmonic Drive	Inside vessel, Stepper motor + Harmonic Drive	Outside vessel, both manual or stepper motor actuation
Nominal frequency	1.3 GHz	1.3 GHz	1.3 GHz
Nominal tunable range	600 kHz	500 kHz	900 kHz
Nominal sensitivity	1.5 Hz/step	1 Hz/step	3 Hz/step
Piezo	2, thin-layer (0.1 mm), dim. 10×10×40 mm ³	2, thin-layer (0.1 mm), dim. 10×10×40 mm ³	1, thick-layer (2 mm), dim. diameter 35×78 mm ²
Piezo Voltage	200 V	200 V	1000 V, operated at 500 V
Nominal piezo stroke at R.T.	55 μm	55 μm	40 μm
Nominal piezo capacitance at R.T.	8 μF	8 μF	0.9 μF

Based on S1-Global

Overall layout for cryogenic system and cooling scheme

7 cryogenic stations for 30 km for 500 GeV
 5 cryogenic stations for 20 km for 250 GeV

Figure 3.24
 The overall layout concept for the cryogenic systems for both flat (KCS) and mountain (DKS) topography.

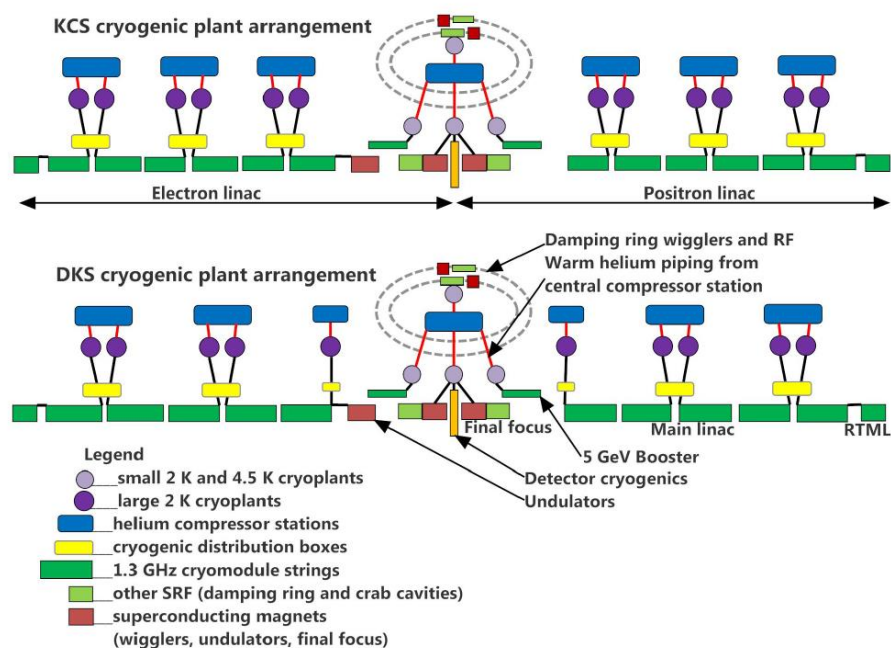
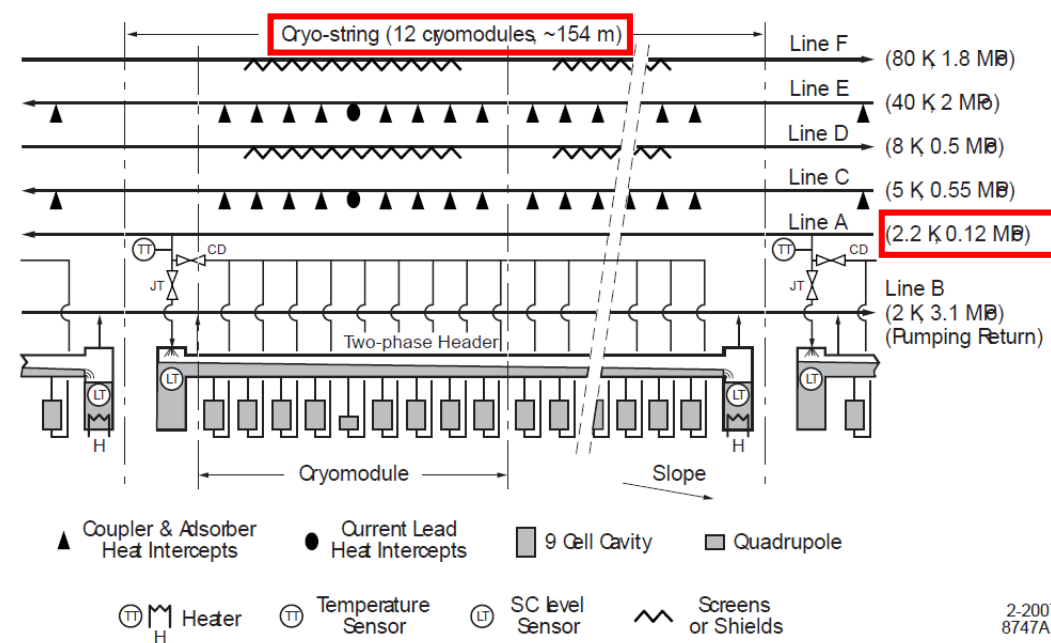

Figure 3.25
 Cooling scheme of a cryo-string.



2-2007
 8747A

Each CM string is cooled down from upstream to downstream

Work packages of SRF at ILC (it's too early!)

Item	Brief description
1.3 GHz Cavities	Order/fabrication, preparation , surface treatment, VT
1.3 GHz cavities for positron beam booster	T.B.D., 3 types of CM, Not necessary for many cavities, Order/fabrication, preparation , surface treatment, VT
1.3 GHz cavities for electron beam booster	T.B.D., Not necessary for many cavities, Order/fabrication, preparation , surface treatment, VT
Power couplers	Order/fabrication, preparation, assembly, high power test
HOM couplers	Order/fabrication, tuning
Frequency tuners incl. piezo	Order/fabrication,
Cavity string assembly	Overall works in clean room
Cryomodules	Order/fabrication, assembly incl. waveguide system (preparation by HLRF), cold test
Cold vacuum incl. HOM damper	Beamline connection of CM-to-CM, Pumping systems, Open/close gate valves
SC Q/D-magnet + BPM Systems	Order/fabrication, test
Alignment	Cavity-to-cavity, Cavity-to-CM, CM-to-CM
650 MHz Cavity System	For damping ring, KEKB type?
Crab Cavity System	For head-on collision, Design not fixed, Discussion is necessary with BDS group
High Level RF System	Klystron, modulator, waveguide, dummy load, variable hybrid, phase shifter, circulator?
Low Level RF System	Construction of control systems incl. feed-forward/feed-back (closed-loop operation)
Cryogenics	For VT and module test, He/N ₂ line connection in tunnel
Global CM transfer	CM transfer to Japan by ship
High pressure gas regulation	To satisfy Japanese law
Installation	CM installed into accelerator tunnel
Machine protection (?)	Performance degradation, dark current, radiation security, possible quench of SCQ-magnet, etc.

Questions/Discussions/Comments (memorandum) @22nd meeting

Translation by Kirk

- Tuner expert meeting
 - At ILCX2021, M. Liepe will present the status of blade tuner used at Cornell Injector CM.
- Meeting with T. Peterson
 - Number of bunches used for HOM heat load estimation in TDR should be clear.
 - It is found from the experiment done at S1-Global that the removal of 5K thermal shield is available for ILC.
 - We need the result of heat load measurement at LCLS-II.
 - Sam will ask some experts, maybe Tug Arkan (co-author of the paper for S1-Global).
 - The dynamic heat load is dominant, and static is negligible at LCLS-II. Then, it may be difficult to show clearly.
 - The heat load at CM test has been measured using mass flow meter at FNAL.
 - If possible, we can have a meeting before ILCX.
- SRF session at ILCX2021
 - Murayama-san requested all conveners to send some information for each session
 - Peter already sent the agenda of crab cavity. He commented EIC workshop will be held at the same time slot.
 - Kirk will send the agenda of CM session soon
 - LOC will have the meeting on 13/Oct (Wed), after that, all programs will be uploaded on INDICO.
- ILC advisory panel of MEXT
 - Second and third meetings will be held on 14/Oct (Thu) and 18/Oct (Mon). It will be done in Japanese!

Questions/Discussions/Comments (memorandum) @ 20th meeting

Translation by Kirk

- Progress of CM design
 - Magnetic shield is installed inside helium tank?
 - This is one discussion item. We can decide which (inside or outside) is better at ILCX.
- SRF session at ILCX2021
 - Kirk showed the preliminary agenda of crab cavity session prepared by Peter
 - If you have any request for this session, please join the 5th crab cavity meeting in 15/Sep

Questions/Discussions/Comments (memorandum) @ 19th meeting

Translation by Kirk

- Preparation for ILC advisory panel
 - TRL is not necessary, also percentages as technology progress
 - Pre-Lab should be 100% as our goal, not construction phase
 - 50% should be put between RDR and TDR
 - Crab cavity for ILC is not mature now, quite different situation from WP-1 and WP-2
 - SC-solenoid at IP has also same situation
- SRF session at ILCX2021
 - 23:30~25:30 @JST is the best solution for all members
 - We will request this extra time table for SRF session after the plenary
 - All conveners for all sessions will be temporarily assigned this week

Questions/Discussions/Comments (memorandum) @ 18th meeting

Translation by Kirk

- Another purpose in ILC
 - ERL option is under consideration

Questions/Discussions/Comments (memorandum) @ 17th meeting

Translation by Kirk

- Explanation on the message from the EB by T. Nakada
- CM drawing
 - Fast-cooling may not need for ILC
 - Double magnetic shields may not be also necessary
 - One pipe for pre-cooling is enough
 - Typical static heat load is around 6 W in LCLS-II, same as E-XFEL
 - Lower part of 5K thermal shield is not necessary for ILC, as suggested in TDR
- Crab Cavity
 - Kirk presented the current situation on behalf of Peter
 - Down-selection to final design of crab cavity will be done in two stages
- European workshop for higher gradient technology
 - On 7/Jul, SRF session will be assigned, and KEK can present about the SRF technology for ILC, and the recent situation of ILC
 - Michizono-san and Kirk will join to present

Questions/Discussions/Comments (memorandum) @ 16th meeting

Translation by Kirk

- WBS
 - Looks WBS of EIC (Joe presented in the sources meeting on this Monday) is quite different from ILC
 - Currently, “Area Systems” is positioned at the top category, and “Technical Systems” is the next
 - Looking for a better solution to summarize
 - If you have new inputs, please tell us
- CM drawing
 - Better to start from the drawing based on LCLS-II than that developed in GDE
 - Sending the drawing of LCLS-II is currently in progress, but will be a little late
 - This includes SC-magnet, coupler, cavity, tuner, HOM damper, etc
- HPGS
 - Before testing CM abroad as the first performance test, you need to get the approval from the authorized person of HPGS from Japan (probably)
 - Production of CM → Inspection for HPGS → Cold test at each lab. → CM transfer → Inspection for HPGS at KEK → Cold test at KEK
 - IFMIF project in QST/Japan is different from ILC
 - Their CM is never constructed in CEA, all components including resonators are delivered to Japan, then constructed there
 - QST dose not need to get the approval of HPGS at CEA
- Tuner
 - Take care of this issue
 - Some experts can give advice/comment

Questions/Discussions/Comments (memorandum) @ 15th meeting

Translation by Kirk

- WBS
 - Conceptual design for CMs in SC booster linac and DR is sufficient during the Technical Preparation Period, not necessary for the detailed design
 - In FCC and EIC projects, 650 MHz CM will be used, as synergy effect, then some R&D may be necessary in HOM damping and others even for ILC
 - Special type of CM may be not necessary, standard type of CM as modified version can be used for booster linac
 - CM package standardization may be necessary
 - Cost estimation on these CMs is needed during TPP
 - The ratio of FTE-yr between Japan and abroad will be adjusted for WBS
- Tuner
 - Re-baseline design for tuner system is necessary
 - Slow tuner in LCLS-II looks no problem, but fast tuner should be demonstrated in pulsed operation
 - Following the LCC policy, we need to submit “Change Request (CR)” to EB in the end
 - In HTS at FNAL, Double-lever tuner can/may be tested in the pulsed operation after the test for LCLS-II-HE?
 - The test items including setup should be discussed, and some additional components are necessary
 - This is very important demonstration before TPP starts
 - Q_{ext} in LCLS-II is different from ILC, but variable?
 - E_{acc} is around 20 MV/m, not 31.5 MV/m (is it o.k.?)
 - LLRF/HLRF systems need to be prepared
 - Availability and cost estimation should be considered for tuner selection
 - In GDE, one important factor was cost, and currently it's still same

Questions/Discussions/Comments (memorandum) @ 14th meeting

Translation by Kirk

- WBS
 - Scope and Deliverables for each item should be well-considered
 - SRF Group is responsible for 650 MHz SRF system in DR?
 - We can think of the both directions, Area System and Technical Items
 - Probably, complicated matrix for HR is necessary for the both directions
 - Some people join the ML and SRF, and also DR
 - J-LAB was responsible for 650 MHz SRF system in RDR and TDR
 - Tuner design is categorized in WP-1, and tuner production in WP-2
 - The deadline of WBS is around one month later
 - Americas and Europe will start to negotiate with their governments from the end of this month
 - WBS is the useful item for this
 - In WP-3, WBS will be discussed in the next meeting
 - In the next SRF Group meeting, we can discuss more
- Tuner
 - Yuriy presented the tuner review as one good candidate for ILC
 - Bias voltage is necessary for piezo drive?
 - Change of LFD is one direction, then it is not necessary
 - When we change the design of tuner from TDR, we need to submit the change request by convention
 - Expert meeting should be organized to be discussed soon
 - This organization is Kirk's homework
 - In pulsed mode, LFD compensation is not too difficult as there are only linear changes
 - It is important to suppress ringing of cavity as much as possible

Questions/Discussions/Comments (memorandum) @ 13th meeting

Translation by Kirk

- Update of TPD
 - Presented the changed part in WP-1, 2, 3
 - Akira Yamamoto-san presented WP-3 on behalf of Peter , and discussed with Sergey and Bob Rimmer to modify the sentences
 - Updated TPD should be finalized in this week
 - After the response from Peter about WP-3, Kirk will upload the SRF part as the final version on INDICO
 - Any question/comment by the end of this week
- Recent progress in KEK
 - KEK already started to negotiate with the local government in Ibaraki prefecture, and will visit to the main office on April
- Next meeting
 - All parts (not only SRF, but Sources, BDS/DR/Dump) of TPD should be finalized
 - EDR preparation will start

Questions/Discussions/Comments (memorandum) @ 10th meeting

Translation by Kirk

- International review
 - The chair person is Dr. Tor Raubenheimer at SLAC
 - All presenters were fixed in this meeting, because we don't have enough time to prepare for the review
 - Peter will present WP-3 including the proposals from the other institutes
 - Dates not fixed yet, but at the end of Feb. or early Mar. (under progress)
 - Each presentation has 30 min including questions
- Crab cavity workshop
 - What is the criteria for technical items?
 - Kirk will explain again at the introduction of the workshop
 - SLAC/BNL/LBNL will join
 - Anyone will be assigned as a coordinator, or co-organizers after this workshop?
 - Focus on technical issues, not decisions
 - Final circular including the zoom link will be delivered soon
- Technical preparation document
 - Version 4 was released just before this meeting
 - Authors and participating laboratories list were checked by the SRF subgroup members
- High pressure gas safety act for ILC
 - Akira Yamamoto-san explained the recent progress about HPG safety act
 - Recent SRF applications were presented, IFMIF, RILAC, LCLS-II, HL-LHC crab cavity
 - Communication with QST, CERN, FNAL, JLAB, SLAC has been done

Questions/Discussions/Comments (memorandum) @9th meeting

Translation by Kirk

- Crab cavity workshop
 - The workshop date is fixed on 18/Feb
 - All speakers agreed to join and present their proposals
- Technical preparation document
 - The document is separated into public part and confidential part
 - Cost/FTE-yr/Participating labs. are included in the confidential as appendix
 - Cost estimation is committed? Authorized by DG?
 - At international review, cost estimation will be reviewed. First of all, this has to be done by bottom-up scheme.
 - In Europe, the situation to get budget is too complicated. Negotiation should be done each by each country.
 - In this document, general cost/FTE-yr are shown regardless of individual circumstances, but local cost is different at each region.
- International review
 - The date is not fixed
 - Presenter for WP-3 will be decided in the crab cavity workshop
- High pressure gas safety act in Japan
 - Detailed presentation was given by Akira Yamamoto-san (Nakai-san's slide is also useful to understand)
 - When cavity/CM to transport to Japan is manufactured abroad, we (KEK/Abroad Labs or Company) need to visit to KHK (High-pressure gas authority of Japan) and local government (Ibaraki-ken, Iwate-ken and etc.) to discuss something "before production". After their agreement to produce cavity/CM or construct SRF accelerator, we can start the production. We have to submit a lot of documents, drawings, inspection sheets, and etc. We need to get High-pressure gas safety act diploma (KEK can support instead of abroad labs.).

Questions/Discussions/Comments (memorandum) @ 8th meeting

Translation by Kirk

- International review
 - Global situation and proposal can be presented, not status of each region and R&D
 - Technology topics are included?
 - The background can be presented
 - Recipe for surface treatment, Nb material, design of tuner/coupler/SCQ-Mag
 - FNAL can present about WP-1
 - After the crab cavity workshop, this review will be held, and someone will present about WP-3 (to be discussed in the workshop)
- Detailed explanation on cost estimation based on TDR
 - MILCU is used up to when?
 - Translation table should be added in the table
 - How much is MILCU expectedly increased in 2022-2025?
 - 20-30%, or 10-15%?
- Crab cavity workshop
 - Should be held before the international review
 - At 17/Feb, Snowmass will be held in US, 18/Feb is much better
 - Kirk is the chair person for this workshop, but after this, we have to discuss who leads the activity of crab cavity?
 - And, also who will present in the international review?
 - Other technical items should be discussed
- LCWS2021
 - Not fixed yet, but there are four parallel sessions incl. CLIC
 - Until the end of Jan, it will be fixed

Questions/Discussions/Comments (memorandum) @ 7th meeting

Translation by Kirk

- Transport of crab cavity CM
 - Cost estimation of crab cavity CM transport looks reasonable
 - TRIUMF has a plan to transport the CMs of crab cavity for HL-LHC, on the ground and by plane
 - Cage and shock damper will be designed and developed
- Infrastructure of hub-lab
 - In Europe, request from each lab. will be summarized, very complicated
 - In US, FNAL/JLAB have some new ideas for CM production at the double rate
- Coupler cost/# of SC-Q
 - Additional explanation for the changed items
 - Coupler cost includes mainly mechanical production, quite different from cavity production (incl. surface treatment, He-tank, magnetic shield, VT, etc.)
- # of CM in US may be doubled
 - In this draft, necessary to consider well-balance among three regions or more
 - In the ideal case, 1/3 at Asia, 1/3 at Americas, 1/3 at Europe
 - Baseline (Maximum/minimum success?) can be presented in the draft
- Success yield
 - 90% means the success yield after 2nd pass in TDR
 - 90% should be hold, even if the cost reduction will be successful
 - If we find revolutionary idea/method, how to proceed to be discussed
 - After 3rd pass, to be discussed, but those cavities can/should be used for ILC because of lower cost dissipation
- Crab cavity
 - Special workshop is necessary early 2021, LCWS2021?
 - Mid. of February can be good candidate
 - UK, CERN, FNAL, JLAB and TRIUMF will join
- FTE-yr of Japan is three times higher than abroad?
 - Original number was decided in the ILC action plan
 - In this draft, FTE-yr is based on the ILC action plan, but we changed a little from that

Questions/Discussions/Comments (memorandum) @ 6th meeting

Translation by Kirk

- Budget request
 - Cost of cavity production includes everything from production to cavity string excluding infrastructure as hub-laboratory
 - Helium tank, magnetic shield, surface treatment, clean room work, high pressure gas regulation, VT (after 2nd pass)
 - Additional lecture/meeting is necessary for high pressure gas regulation of Japan (not this year, but needs to be hurried)
 - Unit cost is preferable?
 - Cavity and coupler cost looks valid
 - Coupler production includes preparation work, waveguide system to connect between two couplers for RF processing at test bench excluding klystron/modulator
 - Number of CM in abroad
 - In US, as we already presented in the previous subgroup meeting, totally four CMs will be produced (FNAL/J-LAB), the number is increased
 - The number of abroad production needs to be discussed well in Europe
 - Remaining cavities (not used for CM production) and bad performance cavities
 - If the performance is good and HPG is satisfied, those cavities can be in stock for ILC (may be not used in technical preparation period)
 - If the performance is bad and HPG is satisfied, those cavities can be repeatedly surface-treated and tested to achieve the good performance
 - If the performance is bad and HPG is not satisfied, those cavities can be used for the other purpose
 - If a cavity with poor performance appears, it is necessary to discuss in advance whether or not the cavity equips a helium tank in production
 - Additional infrastructure
 - If you need some additional items, you can put them into hub-lab. infrastructure in ML-SRF-2
 - ex) klystron/modulator, CM test cave, coupler test area, clean room, pre-tuning machine, EP facility, vacuum furnace for heat treatment, etc.
 - UK team needs the CM test area (cave?) as the additionally necessary infrastructure for crab cavity
 - Crab cavity
 - Japan may/can not control the management for this, because too many labs. have strong interest
 - Candidate labs: UK, FNAL, J-LAB, TRIUMF, CERN?
 - In the current budget request, only abroad has some number in budget/FTE-yr
 - CM transportation
 - Simulation and support from DESY are necessary
 - Cost of cage/shock damper looks reasonable
 - Cost of ground transportation to be checked
 - Cost of sea shipment may be increased, if a special container is necessary (because CM length for ILC is longer than E-XFEL)
 - KEK will have the meeting with a transportation company this month
 - Breakdown is necessary for each quantity and FTE-yr for abroad
 - FTE-yr
 - EDR needs some people, then we put 10 FTE-yr for each
 - Release
 - If you keep this sheet confidentially, we can release → already done

Questions/Discussions/Comments (memorandum) @5th meeting

Translation by Kirk

- Plug-compatibility
 - One design should be selected. More than two types, we need two jigs, and will experience complicated situation.
 - We can decide only flanges of cavity and CM, it dose not mean two types are used
- Relation between surface treatment and cost increase
 - We think selection of surface treatment is flexible, but we also need to think about the cost increase related to the selected method
- The words of “mass production” may be misunderstood, it’s much better to use the other ones
- SCQ is included in CM production?
 - Yes, Spain is added as the new contributor
- Steiner will organize the meeting in Europe to discuss cavity/CM production and test, how shared, how proceeding
 - Crab cavity is unknown to discuss
- Budget request
 - Local or global to be submitted?
 - How much precise is the draft?
 - In Japanese case, we need to submit by August of the previous fiscal year. We need to complete the draft by the end of this year, discuss it with EB, and go to each lab. for consultation.
 - In Americas and Europe, it will be a different process. At least, the process will be slower than in Japan.
 - In Europe, we need to hold a meeting because we have to discuss the proposal first
 - The SRF budget request does not include the cost of infrastructure as function of hub-lab, but FNAL and J-LAB plan to construct new experimental facilities. If it is built during the technical preparation period, the new experimental facility will be available only around the final fiscal year, and there will not be enough time to demonstrate its function as a facility.
 - There are various approaches in each lab and each region, and it is difficult to unify all of them. Of course, it may be behind the expected plan, so you don't have to think so seriously.
- The SRF subgroup concluded that there are three main tasks (cavity/CM production, global CM transfer, crab cavity) during the technical preparation period
 - If there is more input from Europe and Americas, we think it can be added later
- How about the SRF subgroup meeting on 22/Dec?
 - CERN and Spain are on Christmas holidays
 - Americas has no problem

Questions/Discussions/Comments (memorandum) @4th meeting

Translation by Kirk

- Reports from U.S.
 - M. Liepe presented the schedule/task list
 - There are two stages of cavity production; yield study (1) and yield study (2), totally 60 new 9-cell cavities produced
 - To be discussed yield study (2)
 - Really necessary? By new vendor in US? By new recipe?
 - Global CM transfer done in 4th year of technical preparation period. It's also to be discussed.
 - S. Posen presented the infrastructure of CM assembly in FNAL
 - Two lines of cavity string assembly available in clean room enlarged for PIP-II
 - In CM test area, one CM test available. For second, space of klystron to be checked
 - Test stand of power coupler to be discussed/checked
 - B. Rimmer presented the present infrastructure of CM assembly/test, and upgraded plan for ILC in J-LAB
 - Three assembly lines of CM and one cave for CM test at present for CEBAF, LCLS-II-HE, and SNS
 - Possibly additional clean room, and test cave to be constructed in the same building
 - Requests from Akira and Kirk
 - **Tuner should be put to the list, and we need to discuss the final design between Japan and U.S. before the technical preparation period**
 - Please consider the preparation area/test stand of power coupler in U.S. labs. (one klystron maybe available for both CM test and power coupler test)
- **Task list to be fixed in the next SRF subgroup meeting on 24/Nov**
 - **Any other than cavity/cryomodule production, and cryomodule transport recommended in ILC project implementation?**
- Cost down R&D
 - **Think about the balance between cost increase and performance improvement**
 - In LCLS-II-HE, EP x 3 and HT x 2 (In TDR, EP x 2 and HT x 1), but may be reduced the number in future
 - In TDR, the number of final EP was limited to up to twice to evaluate the success yield
 - In TDR, 10 % margin in RF power
 - For higher gradient operation than TDR (above 35 MV/m @CM operation), piezo should be improved for wider frequency range
 - **We should not change number of cavity/CM/klystron from TDR**
 - To be discussed in the next LCWS, and TTC meeting 2021, and to be reconfirmed
- Crab cavity
 - **Kick-off meeting held on 24/Nov 30 min earlier the SRF subgroup meeting, organized by Okugi-san (as the leader of BDS Gr.) and Kirk**
 - Design of cavity, coupler, tuner, CM to be discussed, establishment of collaborators, possible schedule, what we can do before technical preparation period
 - Every member of SRF and BDS subgroup can join, and Kirk will send the invitation to G. Burt and R. Calaga
 - If you know any other candidate person, please tell me before the next meeting
- High pressure gas regulation
 - Kirk explained very shortly (the time is over)
 - Necessary for longer time to discuss in the future meetings
 - Before cavity/CM production in Japan, we have to visit to KHK (authority) and discuss with them; need to pass each by each step (too complicated processes)
 - CEA has the experiences for HPG of Japan, and U.S. labs. have different situation (DG in each lab. can make a decision for HPG)

Questions/Discussions/Comments (memorandum) @ 3rd meeting

Translation by Kirk

- 50 cavities satisfied with HPG? Or not? Cost should be effectively used. Cavities w/o helium tank is used for only estimation of success yield
 - 10 cavities w/o tank in 1st year, 10 cavities w/ tank satisfying with HPG in 2nd year...
- Necessary for learning impact on high pressure gas regulation of Japan
- How much is one cavity estimated?
- Flexibility in surface treatment is necessary, to be discussed
 - To be decided in technical workshop
- International workshop is necessary to review material/fabrication/surface treatment methods
 - plug-compatibility reconfirmed
 - To be held after TTC meeting 2021 or next LCWS2021?
- New vendors in US
 - Important to find cavity fabrication vendor, in not only US but the other countries
 - To be checked qualification, learning curve expected, capability of large number production, etc.
- In GDE, cost estimation has been done by some vendors, but one vendor was dominant
- Reexamine lesson/learned from what GDE have done
- After E-XFEL construction, cavity fabrication cost is not changed, or a little changed
 - Cost of power coupler increased
- Laboratory-vendor collaboration in cavity fabrication is also necessary
 - KEK has already done
- Year and year plan is necessary in each region for technical preparation period
- Americas laboratory proposals in next meeting
 - Kirk requests responsible persons in each lab.

Questions/Discussions/Comments (memorandum) @ 2nd meeting

Translation by Kirk

- CM production
 - Existing CM or New CM?
 - In Japan, before production, we have to discuss with KHK (authority of high pressure gas in Japan)
 - During production, inspection by KHK is necessary
- CM transfer
 - Shipping/High pressure gas regulation can be separated
 - Also rechecking cavity performance after shipping
- No cavity vendor in U.S., but same process as LCLS-II can be used
- How many cavities are produced? 20 at minimum. It depends on budget.
- Fabrication (incl. Nb material)/surface treatment to be discussed
- In TDR, second pass was available. How many times in surface treatment is available? It also depends on cost, and to be discussed.
 - Reliability
 - Cost-effectiveness
- Same method of fabrication and surface treatment as technical preparation period has to be used in construction of ILC
- Global CM transfer among Japan/U.S./EU to be discussed (Japan → U.S./EU?)
 - For fair international collaboration
- There are strict rules in high pressure gas regulation of Japan
 - It may take longer time to solve this
- How many prototypes do we need?
 - No prototype CM in LCLS-II → The construction started immediately (some of existing cavities are used)
 - Three prototype CMs in E-XFEL (PXFEL series)

Questions/Discussions/Comments (memorandum) @ 1st meeting

Translation by Kirk

- Surface treatment
 - Which surface treatment method (EP, HT) is selected in mass production?
 - Surface treatment method is flexible, rather, plug-compatible design of cavity package should be fixed
 - To investigate yield rate, same method should be used. One method in each region (Japan, US, EU)?
 - Always think about which method is used in mass production (performance, cost effective)
 - Choice as advanced technology should be left, even though new method does not work well at present
- Power coupler
 - Power coupler needs a lot of improvements for ILC
 - D. Kostin will present those issues and some suggestions in AWLC2020
- CM transportation
 - 13 CMs will be transferred from EU to US by plane in PIP-II (2023-2024?)
 - CM of ILC needs very large cage for marine transportation. After arrival at Japan, the cage may be sent back.
 - Cost of aerial transportation is much higher than marine
 - Cost of marine transportation is included into budget of each region
 - Design of cage and supporting jigs is necessary
 - “CM transportation” is not appropriate, then ”Global CM transfer” is better?
- Necessary to fix design of tuner/coupler until second year of technical preparation phase when technical review is done
- Additional membership (Michizono-san discussed with Andy and Steiner)
- Budget request of SRF including technical preparation
 - Budget request of subgroup → WG1 → each laboratory → Conclusion of MOU
 - Mass production and Global CM transfer should be summarized to one page for each until end of this year
 - Preparation for conclusion of MOU after Feb/2021
- Introduction of activity of SRF subgroup will be presented in AWLC2020
- Request to upload meeting slide on INDICO