



1.3GHz WOW type crab cavity for ILC

Binping Xiao
Jun 22 2022



WOW type crab cavity

- Crab cavity with wide open waveguides (WOW) was proposed back in 2014 in HOMSC meeting by Fermi Lab colleagues (Quasi-waveguide Multicell Resonator: QMiR).
- CERN colleagues proposed WOW type crab cavity for LHC & FCC in 2015.
- EIC proposed to use WOW+RFD as a backup solution for 394MHz crab cavity.

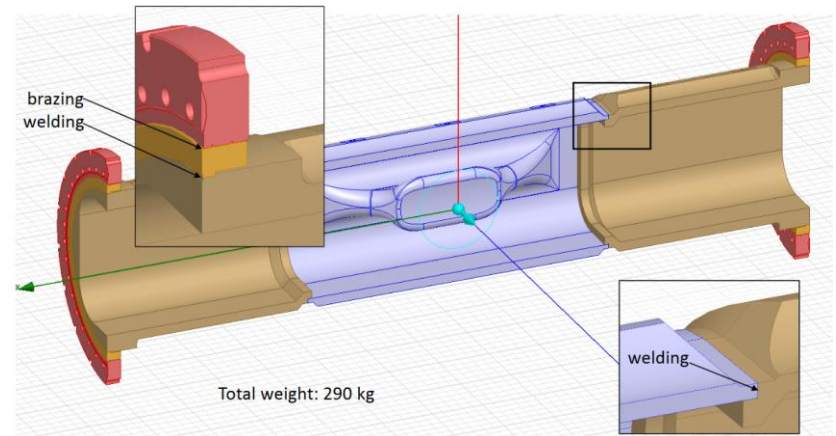
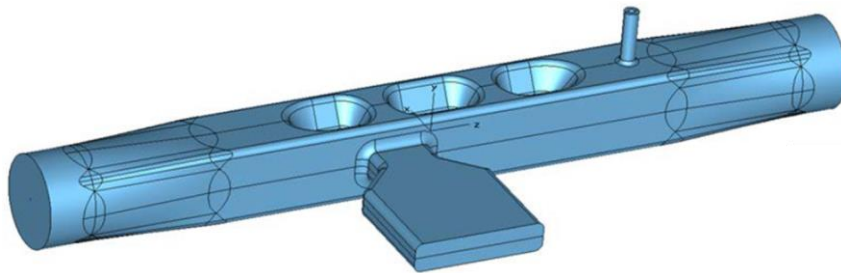

[https://indico.fnal.gov/event/7942/contributions/104178/attachments/68128/81727/HOM Free Deflecting Cavity.pdf](https://indico.fnal.gov/event/7942/contributions/104178/attachments/68128/81727/HOM%20Free%20Deflecting%20Cavity.pdf)

<https://inspirehep.net/files/40359296b280f1cdd0a2b1cb94e33785>

EIC WOW type

(Scaled to 1.3GHz)

- Two SiC absorbers on each side.
- 30.3mm gap & 94mm pipe.
- Vt: 1.27MV, Epk: 50.4MV/m, Bpk: 80.0mT. Can be improved.
- Max imped, longitudinal: $1.5e3\Omega$, transverse: $2.9e4\Omega/m$.
- Needs 6 cavities for 7.4MV.
- Adjacent cavities can share SiC absorbers.
- Total 4.74m.
- Further optimization to lower the peak fields (less cavity number)

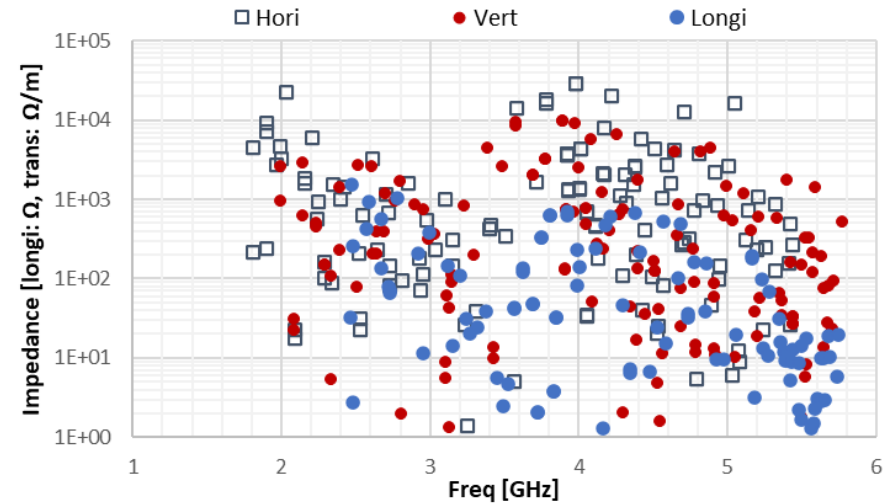

BNL/SLAC joint effort

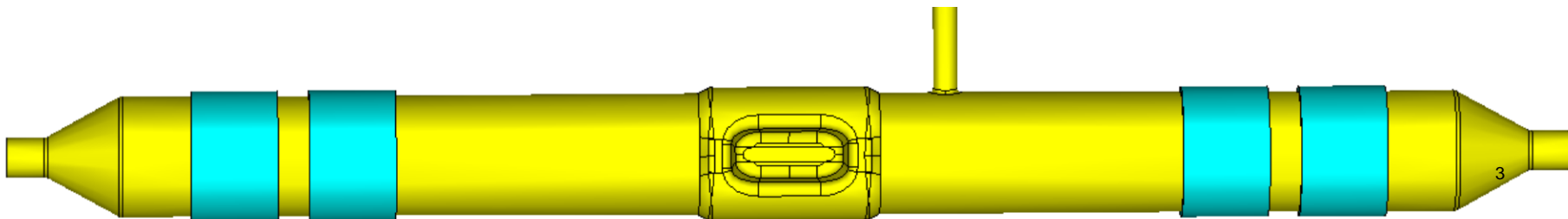

Two major changes in specs v13

- Minimum gap from 20mm to 25mm, number of cavities increases from 4 (1.85MV/cavity) to 5 (1.48MV/cavity).
- Installation length from 3.8m to 3.25m.

Design considerations

- RFD cavity shape, with WOW and ~~beam line absorbers (BLA)~~ Nb waveguide (WG) to coax absorbers on both sides.
 - WG to coax can be shorter than BLA.
 - WG to coax can joint with cavity using indium seal.
 - Fundamental mode can attenuate in WG.
 - While both of them can be detached from cavity.
- First transverse HOM at $\sim 1.8\text{GHz}$, first longitudinal HOM at $\sim 2.3\text{GHz}$.
- Choose 100mm ID WOW
 - with cutoff frequencies at 1.758GHz for TE_{11} and 2.297GHz for TM_{01} .
 - It is a good size for gate valve, no need for tapering.
 - it is also the beampipe size for EIC crab cavities.
- 25mm gap between poles.

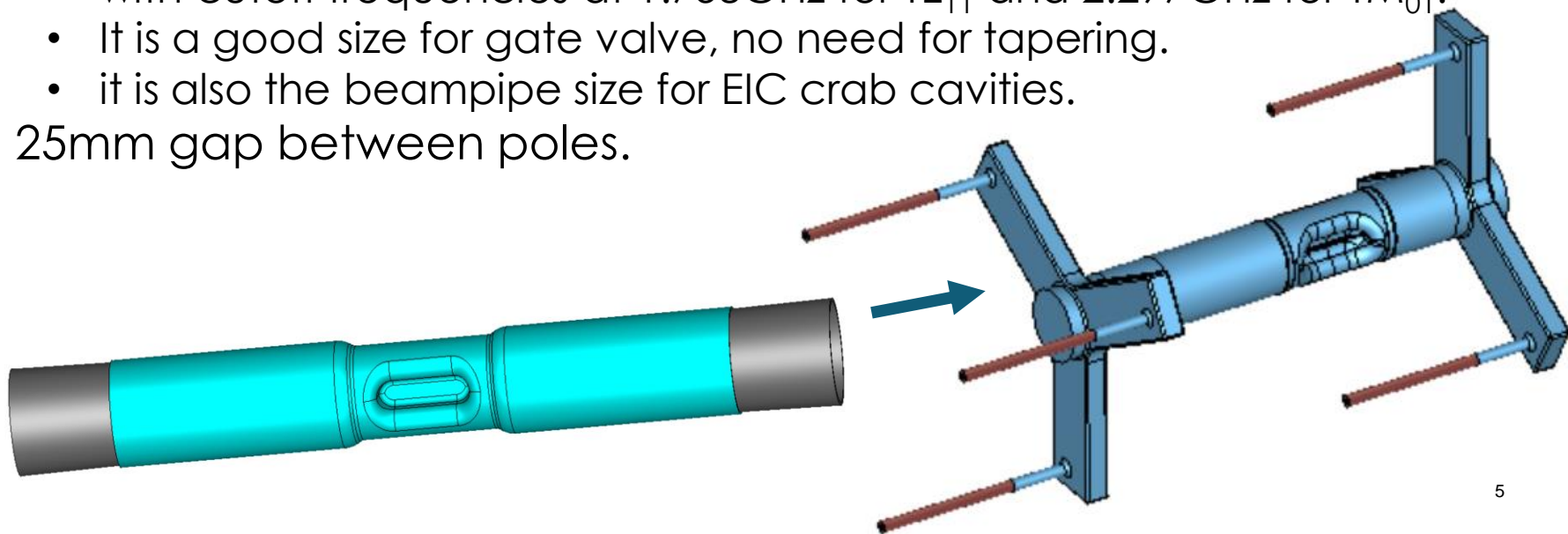

Cavity parameters

Property	Value
Operating frequency [GHz]	1.300
1 st longitudinal HOM [GHz]	2.299
1 st transverse HOM [GHz]	1.765
E_p/E_t with $E_t=V_t/(\lambda/2)$	3.24
B_p/E_t [mT/(MV/m)]	5.75
B_p/E_p [mT/(MV/m)]	1.77
G [Ω]	130.9
R/Q [Ω]	454.3
$R_t R_s$ [Ω^2]	59446

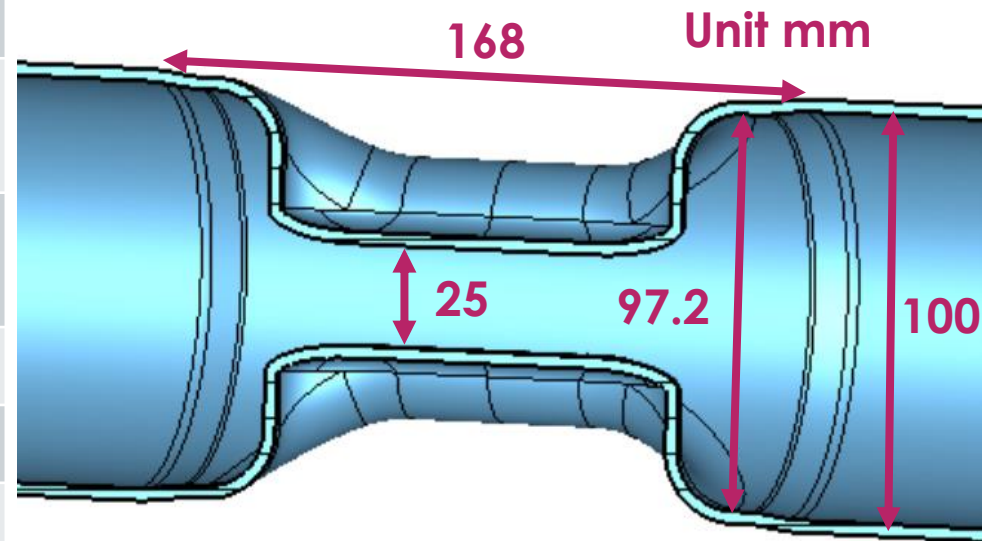

Peak fields

- Needs 1.845MV for 125GeV case and 7.4MV for 500GeV case.
- 5 cavities for 500GeV, meaning 1.48MV per cavity, corresponding to 41.6MV/m E_{pk} and 73.8mT B_{pk} .
- With this we need 2 cavities for 125GeV.
- With 45MV/m E_{pk} and 80mT B_{pk} , cavity could operate at 1.60MV, with a total of 8.0MV from 5 cavities.

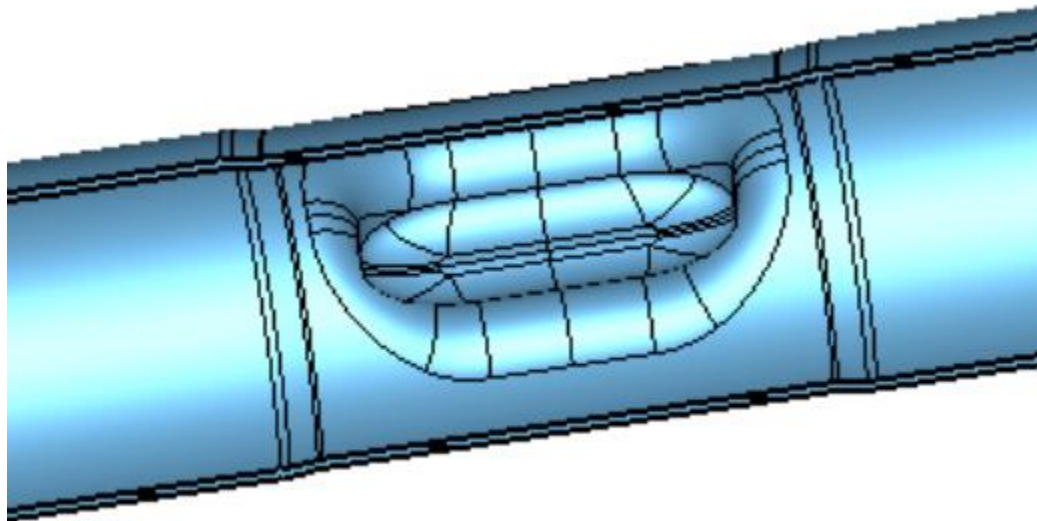

Waveguide to coax damper

- Similar study is on-going for 394MHz EIC crab cavity.
- 86.2mm x 32.3mm rectangular WG to 7/16 coax (port ID 16.2mm), 3 WGs evenly distributed on circular pipe.
- Connection to cavity could be either indium seal or Cu gasket.
- To save space, we can add a few corrugations on the circular pipe so that we do not need bellows between cavities.
- Considering to electrically short 1 WG to reduce the number of coax on each circular pipe from 3 to 2.

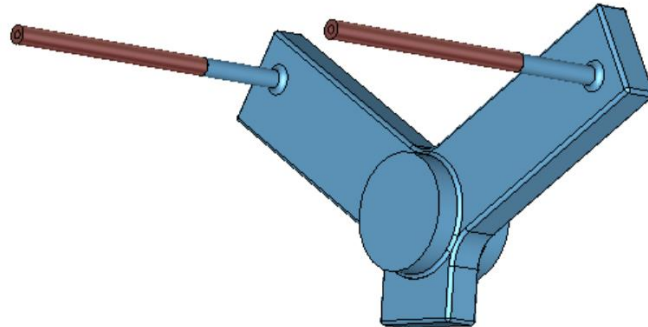

Interfaces

- Cavity helium vessel is placed at 8mT magnetic field Under nominal voltage. Length of helium vessel can be as short as 242mm.
- Indium seal is placed at 2.5mT, located at 168mm from cavity center
- Cu gasket is placed at 220A/m, located at 257mm from cavity center.

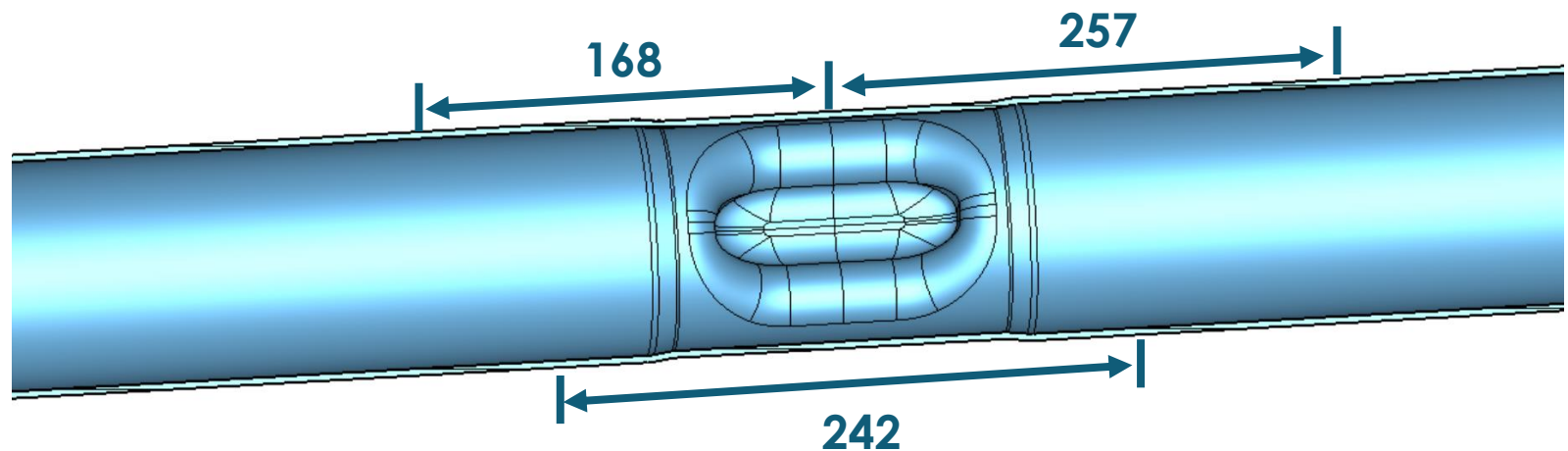

Impedances

- First round of simulation with one damper unit on each side, beampipes are with electrical boundary condition.
- Max horizontal impedance $0.99\text{M}\Omega/\text{m}$, max vertical impedance $0.43\text{M}\Omega/\text{m}$, 1/10 of the budget ($9.76\text{M}\Omega/\text{m}$ horizontal and $12.34\text{M}\Omega/\text{m}$ vertical), all numbers are per cavity.
- Max longitudinal impedance $186\text{k}\Omega$ per cavity, further optimization can be done if needed.
- Simulation on full structure (5 cavities with 6 damper units) with open boundary on beampipe will follow.

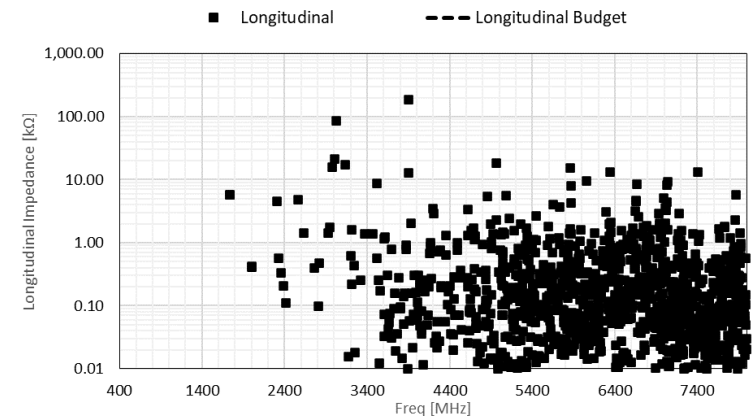
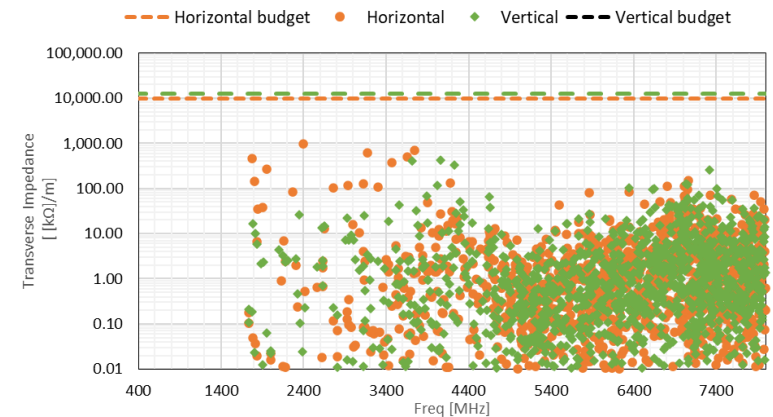
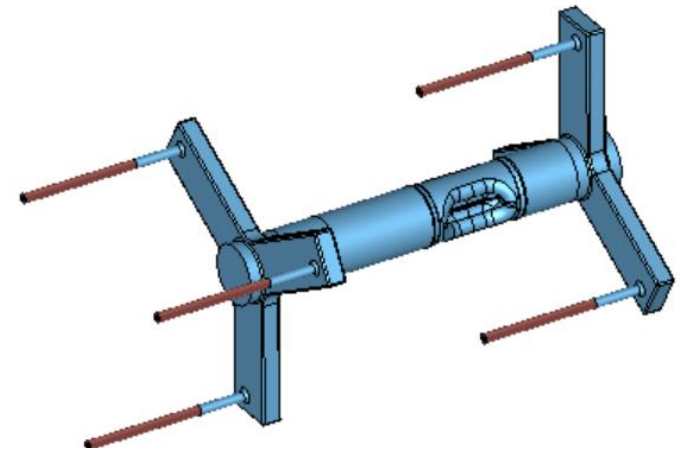

FPC and tuner

- FPC will be similar to the EIC WOW type, coaxial type hook coupler, vertically outside the helium vessel.
- For EIC WOW type, a $5e5 Q_{\text{ext}}$ can be achieved.
- Tuner will be similar to the LHC RFD cavity, with scissor jack tuner applying force symmetrically to the top and bottom (vertically) of the cavity.

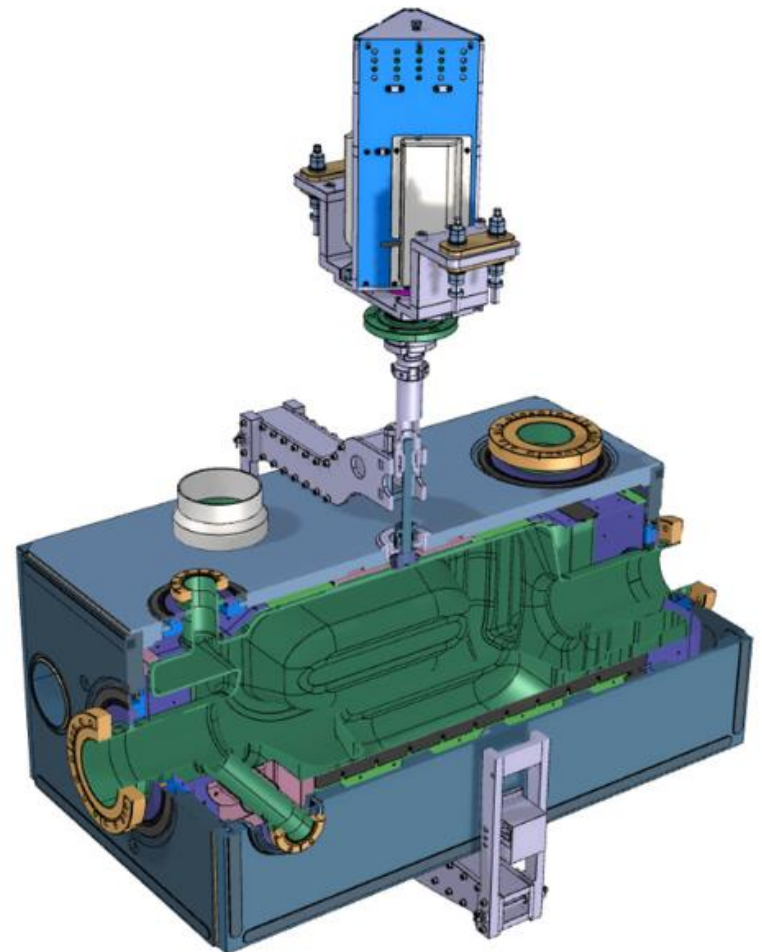
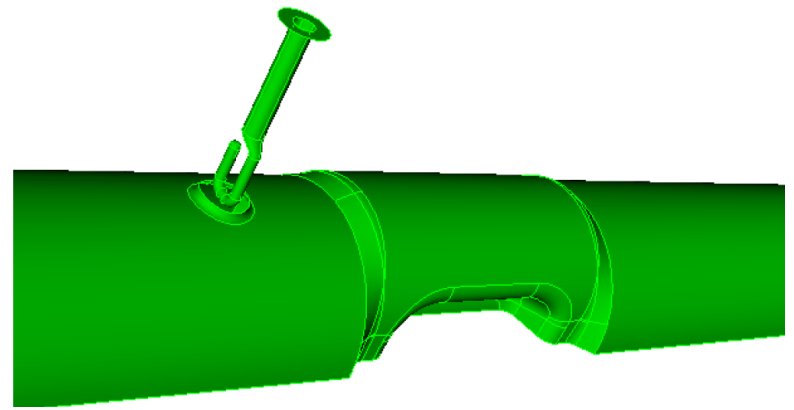

Cavity string (estimation)

- One cryomodule with 5 cavities and 6 damper units.
- Simple design with single cell cavities and damper units between cavities.
- Space reserved for cold-warm bellows, one Tee for pumping and two valves.
- Total length can be 3.25m.
- 2 cavities for 125GeV and 5 cavities for 500GeV.

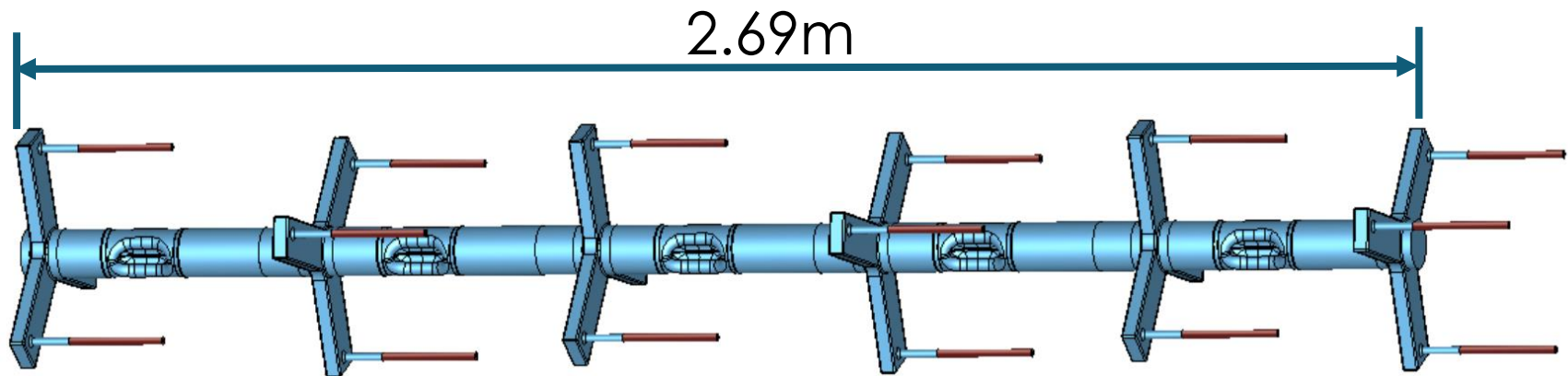

Summary

- WOW + RFD is a good candidate for ILC.
- Simple (robust) cavity design, with FPC/PU/HOM damper all outside the helium vessel.
- Total length can be managed within 3.25m.
- Finished preliminary cavity design.
- Optimization on cavity/damper unit is on-going.
- More effort on ancillaries (FPC/PU, RF window, amplifier, tuner etc) is needed.
- Could be a good joint effort.

